

D	Originalbetriebsanleitung Trockenbauschrauber	SLO	Originalna navodila za uporabo Udarni vrtni stroj
GB	Original operating instructions Drywall screwdriver	H	Eredeti használati utasítás Szárazépítészeti csavarozó
F	Instructions d'origine Visseuse pour pose à sec	RO	Instrucțiuni de utilizare originale Mașină de înșurubat pentru rigips
I	Istruzioni per l'uso originali Trapano avvitatore a impuls	GR	Πρωτότυπες Οδηγίες χρήσης Κατσαβίδι στεγνών κατασκευών
DK/ N	Original betjeningsvejledning Skruemaskine til mørtelfrit elementbyggeri	PL	Instrukcja oryginalna Wkrętarka sieciowa
S	Original-bruksanvisning Gipsskruddragare	TR	Orijinal Kullanma Talimatı Alçıpan Vidalama
CZ	Originální návod k obsluze Šroubovák pro suchou výstavbu	HR/ BIH	Originalne upute za uporabu Izvijač za montažu
SK	Originálny návod na obsluhu Skrutkovač na sadrokartón	RS	Originalna uputstva za upotrebu Vijčanik
NL	Originele handleiding Schroefmachine v. droge bouwplaten	EE	Originaalkasutusjuhend Siseviimistluskruvits
E	Manual de instrucciones original Atornillador para paredes en seco	P	Manual de instruções original Aparafusadora para pré-fabricados
FIN	Alkuperäiskäyttöohje Ruuvinväännin		

13   

Art.-Nr.: 42.599.25

I.-Nr.: 21011

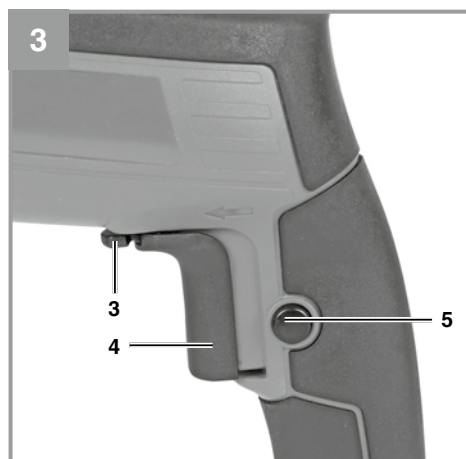
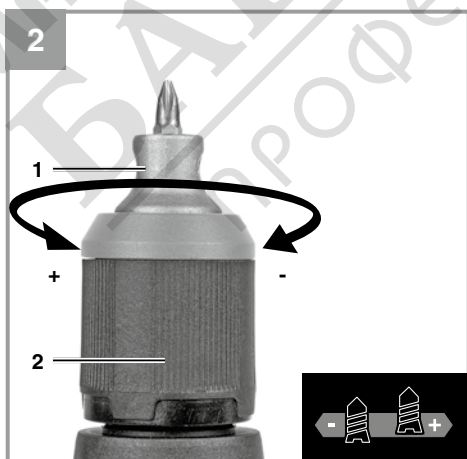
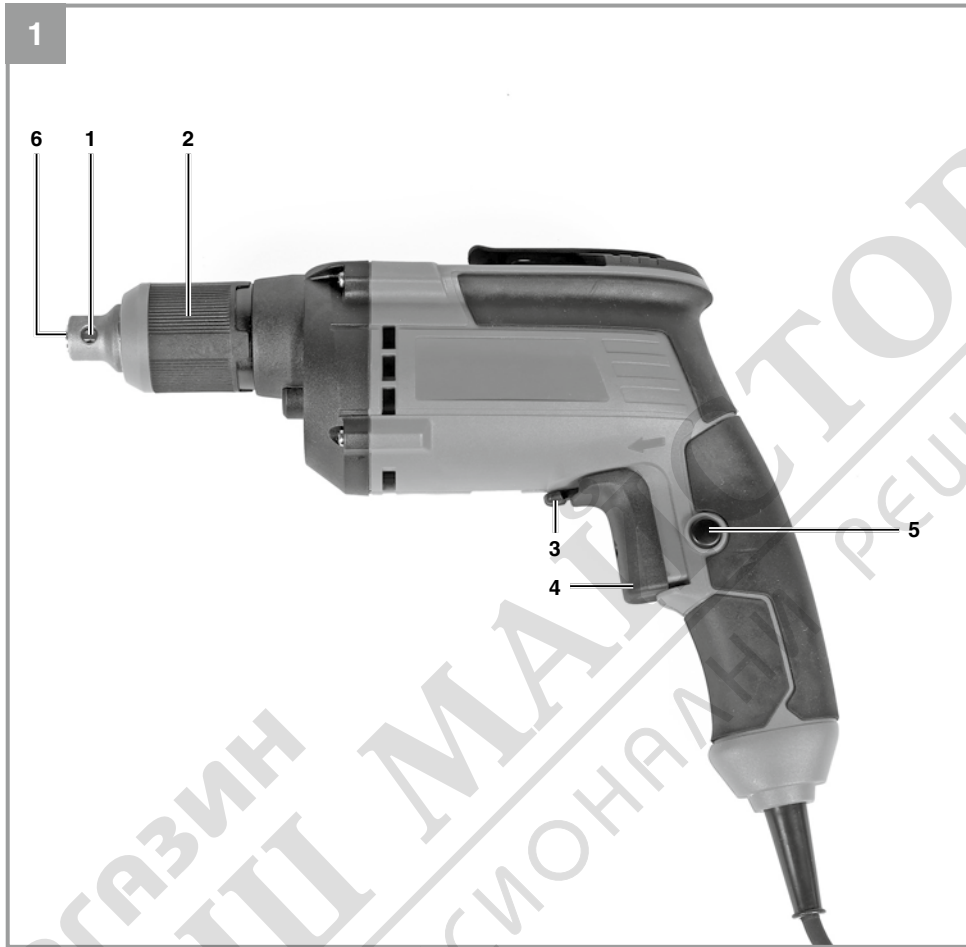

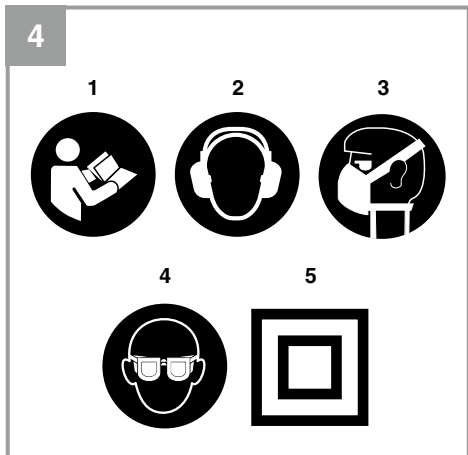

МАГАЗИН МАЙСТОРА
БАШ МАЙСТОРА®
ПРОФЕСІОНАЛНИ РЕШЕНИЯ

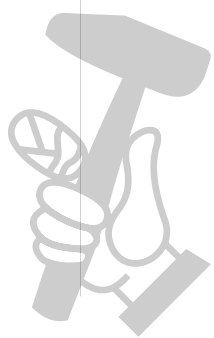

Danger!

When using the equipment, a few safety precautions must be observed to avoid injuries and damage. Please read the complete operating instructions and safety regulations with due care. Keep this manual in a safe place, so that the information is available at all times. If you give the equipment to any other person, hand over these operating instructions and safety regulations as well. We cannot accept any liability for damage or accidents which arise due to a failure to follow these instructions and the safety instructions.

Explanation of the symbols used (see Fig. 4)

1. **Danger!** - Read the operating instructions to reduce the risk of injury.
2. **Caution! Wear ear-muffs.** The impact of noise can cause damage to hearing.
3. **Caution! Wear a breathing mask.** Dust which is injurious to health can be generated when working on wood and other materials. Never use the device to work on any materials containing asbestos!
4. **Caution! Wear safety goggles.** Sparks generated during working or splinters, chips and dust emitted by the device can cause loss of sight.
5. Protection class II

1. Safety regulations

The corresponding safety information can be found in the enclosed booklet.

WARNING Read all safety warnings, instructions, illustrations and specifications provided with this power tool. Failure to follow all instructions listed below may result in electric shock, fire and/or serious injury. Save all warnings and instructions for future reference.

2. Layout and items supplied**2.1 Layout (Fig. 1)**

1. Screwing depth stop
2. Depth setting ring
3. Left/Right switch
4. ON/OFF switch
5. Locking button
6. Chuck

2.2 Items supplied

Please check that the article is complete as specified in the scope of delivery. If parts are missing, please contact our service center or the sales outlet where you made your purchase at the latest within 5 working days after purchasing the product and upon presentation of a valid bill of purchase. Also, refer to the warranty table in the service information at the end of the operating instructions.

- Open the packaging and take out the equipment with care.
- Remove the packaging material and any packaging and/or transportation braces (if available).
- Check to see if all items are supplied.
- Inspect the equipment and accessories for transport damage.
- If possible, please keep the packaging until the end of the guarantee period.

Danger!

The equipment and packaging material are not toys. Do not let children play with plastic bags, foils or small parts. There is a danger of swallowing or suffocating!

- Drywall screwdriver
- Original operating instructions
- Safety instructions

3. Proper use

The screwdriver is designed for the screw-fitting of plasterboard and particleboard panels in the dry section sector.

The equipment is to be used only for its prescribed purpose. Any other use is deemed to be a case of misuse. The user / operator and not the manufacturer will be liable for any damage or injuries of any kind caused as a result of this.

Please note that our equipment has not been designed for use in commercial, trade or industrial applications. Our warranty will be voided if the machine is used in commercial, trade or industrial businesses or for equivalent purposes.

4. Technical data

Mains voltage:220-240 V~ 50 Hz
 Power input: 710 W
 Idling speed: 0 – 4000 min⁻¹
 Tool holder 1/4" (6,35 mm)
 Protection class:II / 
 Weight: 1.83 kg

Danger!

Sound and vibration

Sound and vibration values were measured in accordance with EN 62841.

L_{pA} sound pressure level 83.1 dB(A)
 K_{pA} uncertainty 3 dB
 L_{WA} sound power level 94.1 dB(A)
 K_{WA} uncertainty 3 dB

Wear ear-muffs.

The impact of noise can cause damage to hearing.

Total vibration values (vector sum of three directions) determined in accordance with EN 62841.

Screwing without hammer action

Vibration emission value $a_h \leq 3.87 \text{ m/s}^2$
 K uncertainty = 1.5 m/s²

The specified vibration value was established in accordance with a standardized testing method. It may change according to how the electric equipment is used and may exceed the specified value in exceptional circumstances.

The specified vibration value can be used to compare the equipment with other electric power tools.

The specified vibration value can be used for initial assessment of a harmful effect.

Keep the noise emissions and vibrations to a minimum.

- Only use appliances which are in perfect working order.
- Service and clean the appliance regularly.
- Adapt your working style to suit the appliance.
- Do not overload the appliance.
- Have the appliance serviced whenever necessary.
- Switch the appliance off when it is not in use.

Caution!

Residual risks

Even if you use this electric power tool in accordance with instructions, certain residual risks cannot be ruled out. The following hazards may arise in connection with the equipment's construction and layout:

1. Lung damage if no suitable protective dust mask is used.
2. Damage to hearing if no suitable ear protection is used.
3. Health damage caused by hand-arm vibrations if the equipment is used over a prolonged period or is not properly guided and maintained.

Limit the operating time!

All stages of the operating cycle must be considered (for example, times in which the electric tools are switched off and times in which the tool is switched on but operates without load).

5. Before starting the equipment

Before you connect the equipment to the mains supply make sure that the data on the rating plate are identical to the mains data.

Warning!

Always pull the power plug before making adjustments to the equipment.

- Only ever use screw gun bits which are suitable for the purpose and in faultless condition.
- Before you begin to screw in walls and masonry, check for concealed electric wiring, gas pipes and water pipes.
- The screw gun is equipped with a claw coupling. The spindle does not start to rotate until the screw is pushed into the workpiece.

5.1 Setting the screwing depth (Figure 2)

Using the depth setting ring (2) with latching settings you can pre-select the depth to which the screw is screwed into the workpiece.

PLUS direction: larger screwing depth

MINUS direction: smaller screwing depth

The best way to determine the re-quired setting is with a test screw.

Press the tip of the screw firmly against the material in question until the screwing depth stop (1)

comes up against the workpiece and the coupling disengages.

5.2 Changing the tool insert

To change the tool insert, rotate the screwing depth stop (1) with the depth setting ring (2) as far as the maximum screwing depth and pull off the tool insert to the front (use pliers if necessary).

5.3 Screwdriving work

It is advisable to use self-centering screws (e.g. cross recessed head) as these will enable you to work safely and reliably. Always make sure that the tool insert used is of the same size and shape as

6. Operation

6.1 ON/OFF switch (Fig. 3/Item 4)

To switch on:

Press the ON/OFF switch (4)

Continuous operation:

Secure the ON/OFF switch (5) with the locking button (4).

To switch off:

Press the ON/OFF switch (4) briefly.

6.2 Clockwise/Counter-clockwise switch (Fig. 3/Item 3)

- Change switch position only when the drill is at a standstill!
- Using the slide switch above the ON/OFF switch (4) you can select the direction of rotation of the screwdriver.

Direction

Clockwise

Counter-clockwise

Switch position

Arrow forward

Arrow backwards

7. Replacing the power cable

Danger!

If the power cable for this equipment is damaged, it must be replaced by the manufacturer or its after-sales service or similarly trained personnel to avoid danger.

8. Cleaning, maintenance and ordering of spare parts

Danger!

Always pull out the mains power plug before starting any cleaning work.

8.1 Cleaning

- Keep all safety devices, air vents and the motor housing free of dirt and dust as far as possible. Wipe the equipment with a clean cloth or blow it with compressed air at low pressure.
- We recommend that you clean the device immediately each time you have finished using it.
- Clean the equipment regularly with a moist cloth and some soft soap. Do not use cleaning agents or solvents; these could attack the plastic parts of the equipment. Ensure that no water can seep into the device. The ingress of water into an electric tool increases the risk of an electric shock.

8.2 Carbon brushes

In case of excessive sparking, have the carbon brushes checked only by a qualified electrician.

Danger! The carbon brushes should not be replaced by anyone but a qualified electrician.

8.3 Maintenance

There are no parts inside the equipment which require additional maintenance.

8.4 Ordering spare parts and accessories

Please provide the following information when ordering spare parts:

- Type of unit
- Article number of the unit
- ID number of the unit
- Spare part number of the required spare part

For our latest prices and information please go to www.Einhell-Service.com



Tip! For good results we recommend high-quality accessories from **kwb** !
www.kwb.eu
welcome@kwb.eu

9. Disposal and recycling

The equipment is supplied in packaging to prevent it from being damaged in transit. The raw materials in this packaging can be reused or recycled. The equipment and its accessories are made of various types of material, such as metal and plastic. Never place defective equipment in your household refuse. The equipment should be taken to a suitable collection center for proper disposal. If you do not know the whereabouts of such a collection point, you should ask in your local council offices.

10. Storage

Store the equipment and accessories in a dark and dry place at above freezing temperature. The ideal storage temperature is between 5 and 30 °C. Store the electric tool in its original packaging.

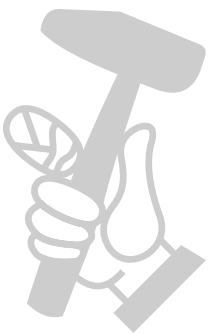



For EU countries only

Never place any electric power tools in your household refuse.

To comply with European Directive 2012/19/EC concerning old electric and electronic equipment and its implementation in national laws, old electric power tools have to be separated from other waste and disposed of in an environment-friendly fashion, e.g. by taking to a recycling depot.

Recycling alternative to the return request:

As an alternative to returning the equipment to the manufacturer, the owner of the electrical equipment must make sure that the equipment is properly disposed of if he no longer wants to keep the equipment. The old equipment can be returned to a suitable collection point that will dispose of the equipment in accordance with the national recycling and waste disposal regulations. This does not apply to any accessories or aids without electrical components supplied with the old equipment.

Please note that batteries and lamps (e.g. light bulbs) must be removed from the tool before it is disposed of.

The reprinting or reproduction by any other means, in whole or in part, of documentation and papers accompanying products is permitted only with the express consent of the Einhell Germany AG.

Subject to technical changes

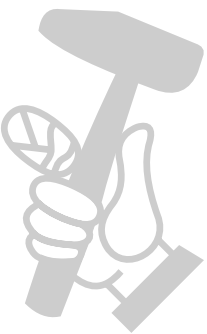

Service information

We have competent service partners in all countries named on the guarantee certificate whose contact details can also be found on the guarantee certificate. These partners will help you with all service requests such as repairs, spare and wearing part orders or the purchase of consumables.

Please note that the following parts of this product are subject to normal or natural wear and that the following parts are therefore also required for use as consumables.

Category	Example
Wear parts*	Carbon brushes
Consumables*	Bit inserts
Missing parts	

* Not necessarily included in the scope of delivery!

In the effect of defects or faults, please register the problem on the internet at www.Einhell-Service.com. Please ensure that you provide a precise description of the problem and answer the following questions in all cases:

- Did the equipment work at all or was it defective from the beginning?
- Did you notice anything (symptom or defect) prior to the failure?
- What malfunction does the equipment have in your opinion (main symptom)? Describe this malfunction.

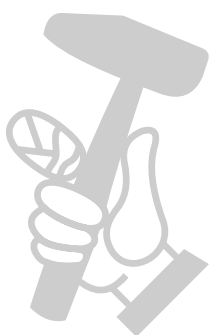

Warranty certificate

Dear Customer,

All of our products undergo strict quality checks to ensure that they reach you in perfect condition. In the unlikely event that your device develops a fault, please contact our service department at the address shown on this guarantee card. You can also contact us by telephone using the service number shown. Please note the following terms under which guarantee claims can be made:

1. These guarantee terms apply to consumers only, i.e. natural persons intending to use this product neither for their commercial activities nor for any other self-employed activities. These warranty terms regulate additional warranty services, which the manufacturer mentioned below promises to buyers of its new products in addition to their statutory rights of guarantee. Your statutory guarantee claims are not affected by this guarantee. Our guarantee is free of charge to you.
2. The warranty services cover only defects due to material or manufacturing faults on a product which you have bought from the manufacturer mentioned below and are limited to either the rectification of said defects on the product or the replacement of the product, whichever we prefer. Please note that our devices are not designed for use in commercial, trade or professional applications. A guarantee contract will not be created if the device has been used by commercial, trade or industrial business or has been exposed to similar stresses during the guarantee period.
3. The following are not covered by our guarantee:
 - Damage to the device caused by a failure to follow the assembly instructions or due to incorrect installation, a failure to follow the operating instructions (for example connecting it to an incorrect mains voltage or current type) or a failure to follow the maintenance and safety instructions or by exposing the device to abnormal environmental conditions or by lack of care and maintenance.
 - Damage to the device caused by abuse or incorrect use (for example overloading the device or the use of unapproved tools or accessories), ingress of foreign bodies into the device (such as sand, stones or dust, transport damage), the use of force or damage caused by external forces (for example by dropping it).
 - Damage to the device or parts of the device caused by normal or natural wear or tear or by normal use of the device.
4. The guarantee is valid for a period of 24 months starting from the purchase date of the device. Guarantee claims should be submitted before the end of the guarantee period within two weeks of the defect being noticed. No guarantee claims will be accepted after the end of the guarantee period. The original guarantee period remains applicable to the device even if repairs are carried out or parts are replaced. In such cases, the work performed or parts fitted will not result in an extension of the guarantee period, and no new guarantee will become active for the work performed or parts fitted. This also applies if an on-site service is used.
5. To make a claim under the guarantee, please register the defective device at: www.Einhell-Service.com. Please keep your bill of purchase or other proof of purchase for the new device. Devices that are returned without proof of purchase or without a rating plate shall not be covered by the guarantee, because appropriate identification will not be possible. If the defect is covered by our guarantee, then the item in question will either be repaired immediately and returned to you or we will send you a new replacement.

Of course, we are also happy offer a chargeable repair service for any defects which are not covered by the scope of this guarantee or for units which are no longer covered. To take advantage of this service, please send the device to our service address.

Also refer to the restrictions of this warranty concerning wear parts, consumables and missing parts as set out in the service information in these operating instructions.