

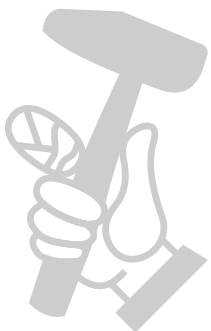

GC-PC 2040 I

D	Originalbetriebsanleitung Benzin-Kettensäge	E	Manual de instrucciones original Motosierra con motor de gasolina
GB	Original operating instructions Petrol Chainsaw	P	Manual de instruções original Motoserra a gasolina
F	Mode d'emploi d'origine Scie a chaine a essence	FIN	Alkuperäiskäyttöohje Bensiinikäyttöinen ketjusaha
I	Istruzioni per l'uso originali Motosega a benzina	RUS	Оригинальное руководство по эксплуатации Бензиновая цепочная пила
DK/ N	Original betjeningsvejledning Benzindreven kædesav	PL	Instrukcja oryginalna Spalinowa piła łańcuchowa
S	Original-bruksanvisning Bensindriven motorsåg	GR	Πρωτότυπες Οδηγίες χρήσης Αλυσοπριονο βενζίνας
NL	Originele handleiding Benzine kettingzaag		



Art.-Nr.: 45.018.51

I.-Nr.: 21043

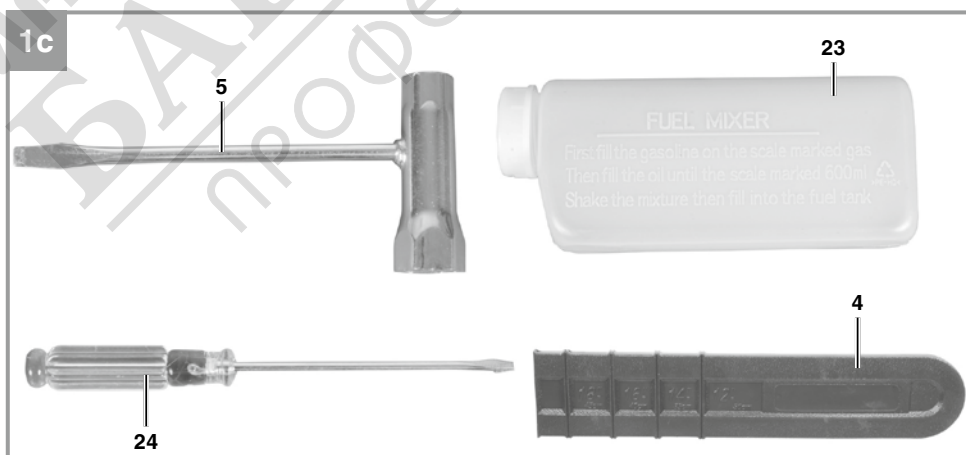
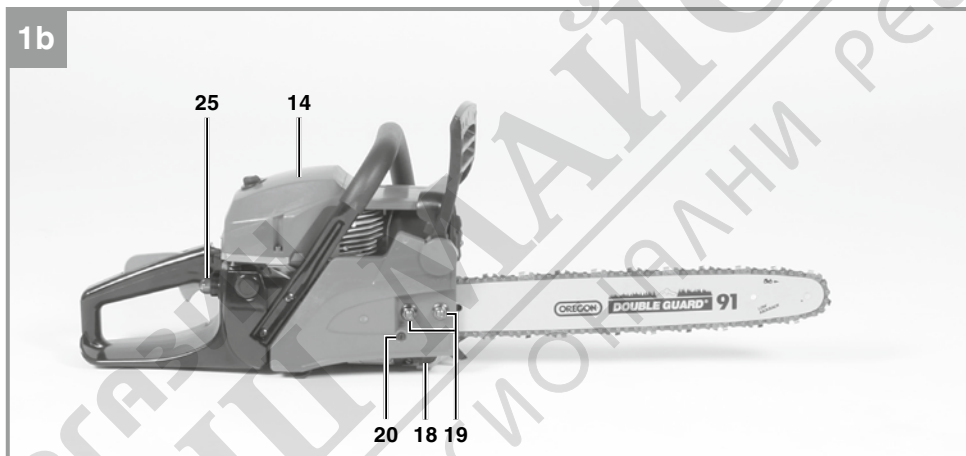
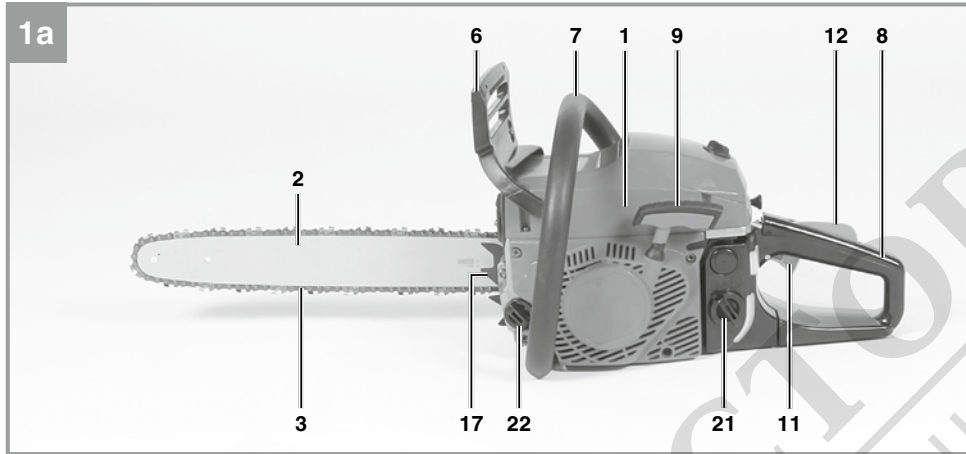

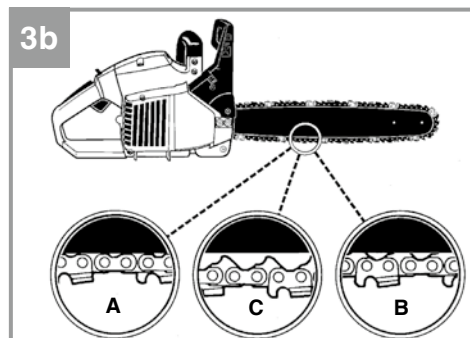
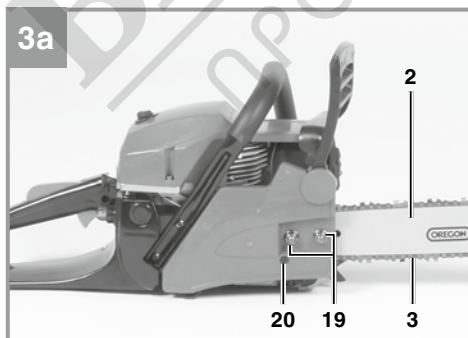
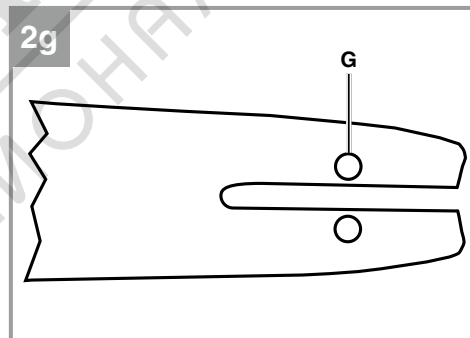
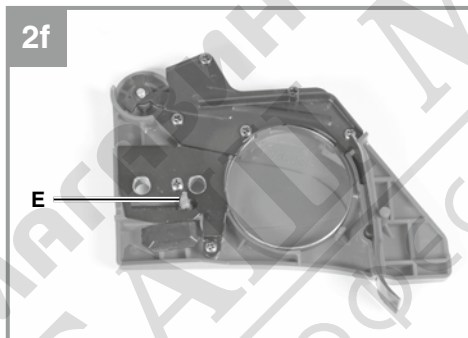
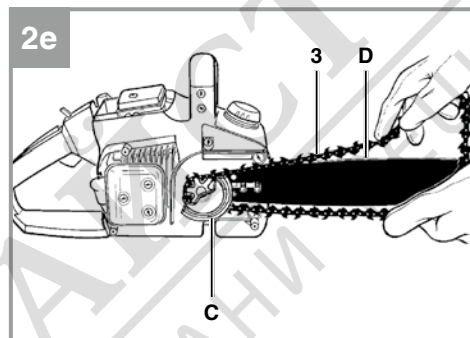
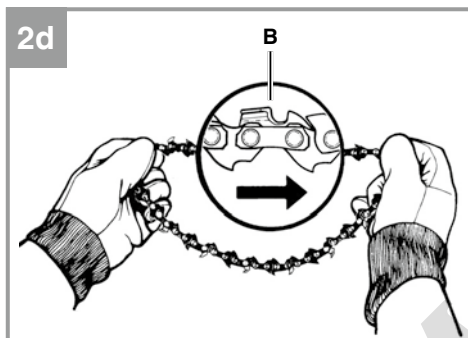
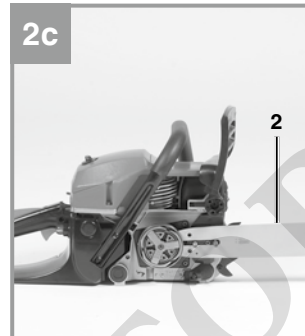
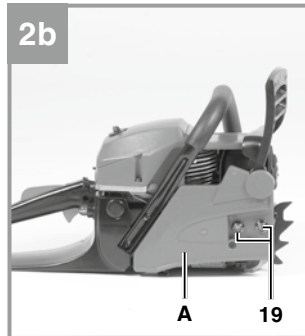
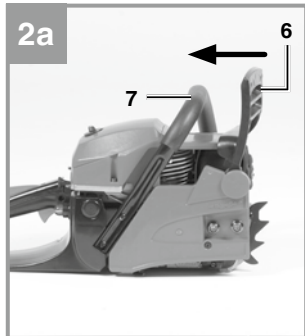

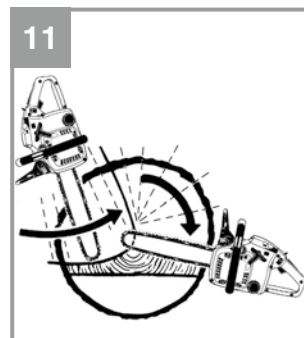
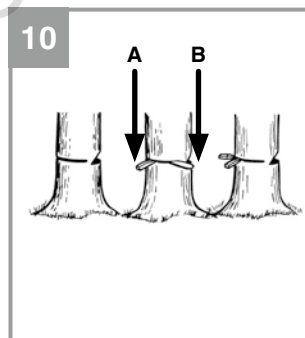
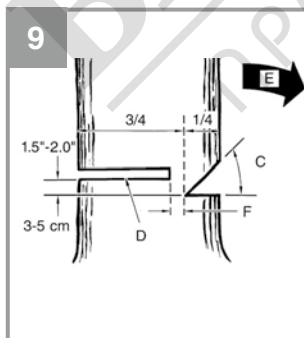
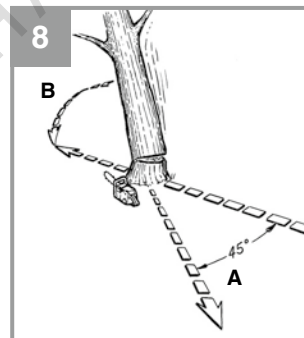
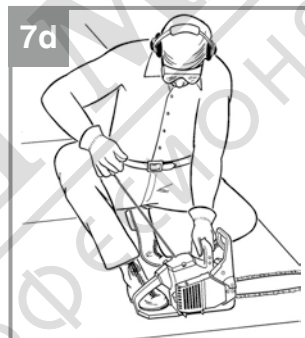
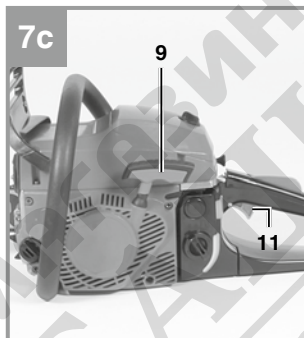
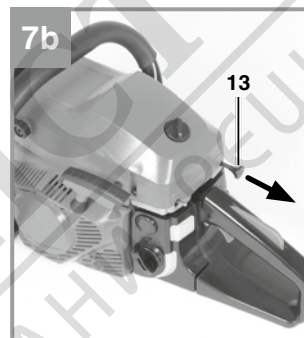
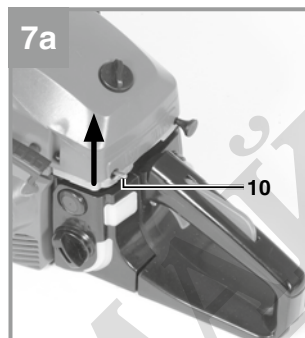
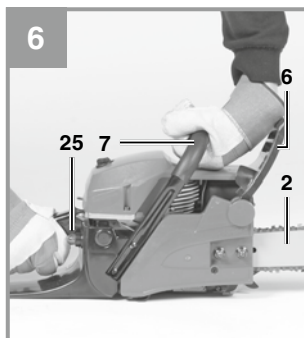
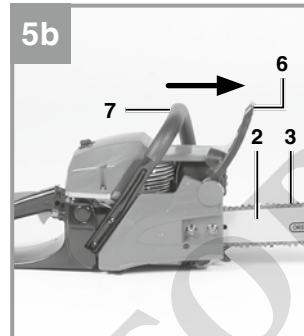
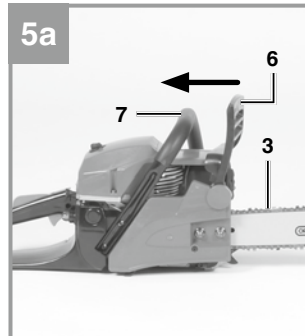
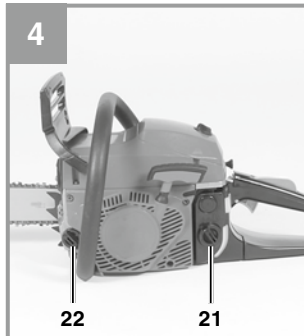

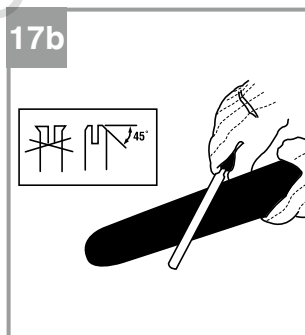
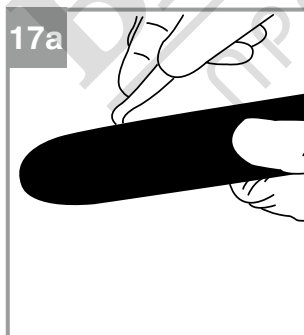
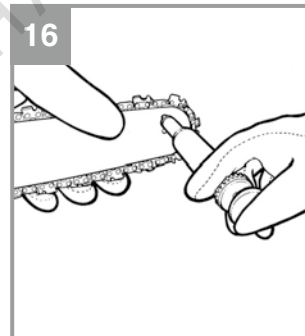
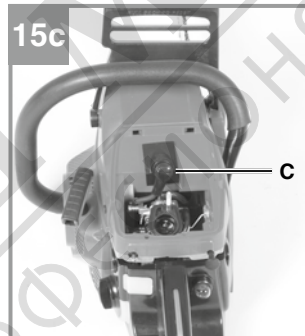
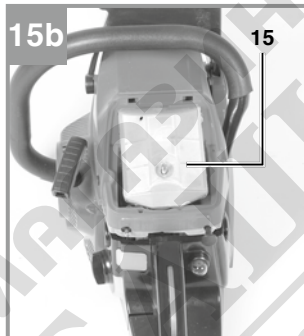
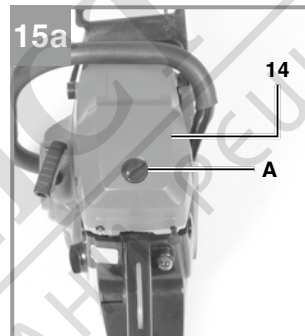
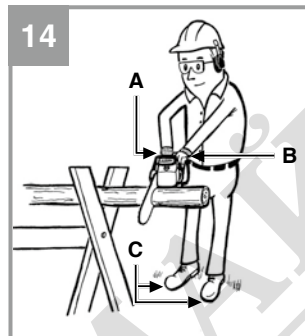
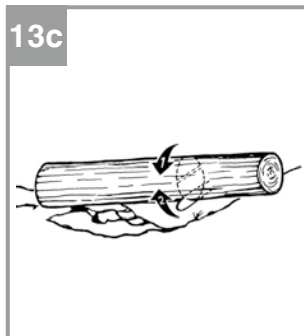
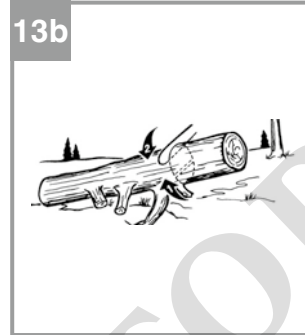
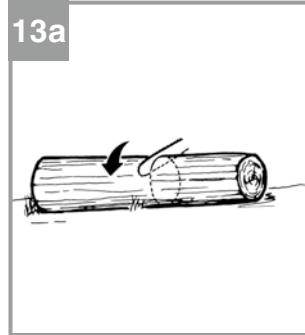
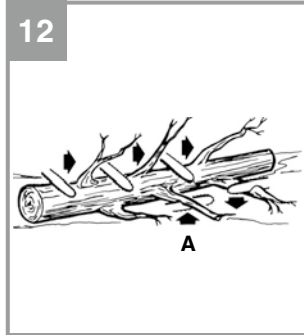

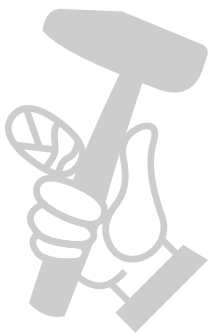
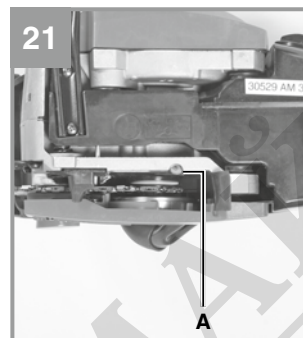
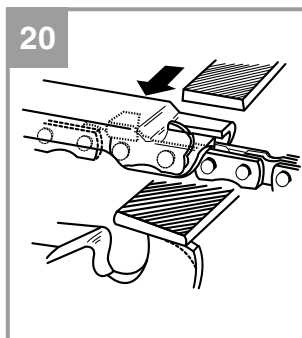
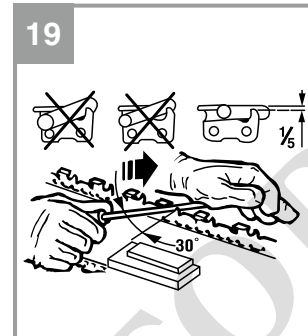
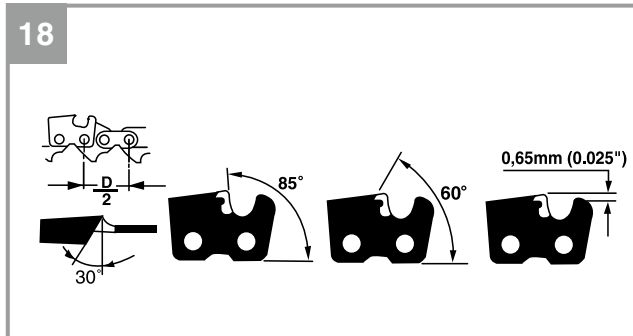

МАГАЗИН МАСТОРА  
БАШ МАСТОРА  
ПРОФЕСИОНАЛНИ РЕШЕНИЯ

**Table of contents**

1. Safety regulations
2. Layout and items supplied
3. Proper use
4. Technical data
5. Before starting the equipment
6. Operation
7. Cleaning, maintenance, storage and ordering of spare parts
8. Disposal and recycling
9. Troubleshooting guide

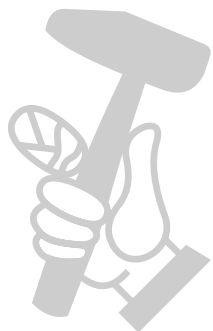

МАГАЗИН  
БАШ МАЙСТОРА®  
ПРОФЕССИОНАЛНИ РЕШЕНИЯ

**Danger!**

When using the equipment, a few safety precautions must be observed to avoid injuries and damage. Please read the complete operating instructions and safety regulations with due care. Keep this manual in a safe place, so that the information is available at all times. If you give the equipment to any other person, hand over these operating instructions and safety regulations as well. We cannot accept any liability for damage or accidents which arise due to a failure to follow these instructions and the safety instructions.

**1. Safety regulations**

The corresponding safety information can be found in the enclosed booklet.

**Danger!****Read all safety regulations and instructions.**

Any errors made in following the safety regulations and instructions may result in an electric shock, fire and/or serious injury.

**Keep all safety regulations and instructions in a safe place for future use.****2. Layout and items supplied****2.1 Layout (Fig. 1-21)**

1. Motor unit
2. Chain bar
3. Saw chain
4. Chain guard
5. Spark plug wrench
6. Front hand guard (chain brake lever)
7. Front handle
8. Rear handle
9. Starter handle
10. On/Off switch
11. Throttle lever
12. Throttle lever safety lock
13. Choke lever
14. Air filter cover
15. Air filter
16. Spark plug
17. Stop claw
18. Chain catch
19. Chain bar fastening nut
20. Chain tensioning screw
21. Fuel tank cap
22. Oil tank cap
23. Mixing container
24. Screwdriver

25. Fuel pump (primer)

**Safety features (fig.1a/1b)**

- 3 LOW KICKBACK SAW CHAIN helps significantly reduce kickback, or the intensity of kickback, due to specially designed depth gauges and guard links.
- 6 CHAIN BRAKE LEVER / HAND GUARD protects the operator's left hand in the event it slips off the front handle while saw is running. CHAIN BRAKE is a safety feature designed to reduce the possibility of injury due to kickback by stopping a moving saw chain in milliseconds. It is activated by the CHAIN BRAKE lever.
- 10 STOP SWITCH immediately stops the engine when tripped. Stop switch must be pushed to ON position to start or restart engine.
- 12 SAFETY TRIGGER prevents accidental acceleration of the engine. Throttle trigger cannot be squeezed unless the safety latch is depressed.
- 18 CHAIN CATCHER reduces the danger of injury in the event saw chain breaks or derails during operation. The chain catcher is designed to intercept a whipping chain.

**Note:** Study your saw and be familiar with its parts.

**2.2 Items supplied**

Please check that the article is complete as specified in the scope of delivery. If parts are missing, please contact our service center or the sales outlet where you made your purchase at the latest within 5 working days after purchasing the product and upon presentation of a valid bill of purchase. Also, refer to the warranty table in the service information at the end of the operating instructions.

- Open the packaging and take out the equipment with care.
- Remove the packaging material and any packaging and/or transportation braces (if available).
- Check to see if all items are supplied.
- Inspect the equipment and accessories for transport damage.
- If possible, please keep the packaging until the end of the guarantee period.

**Danger!**

**The equipment and packaging material are not toys. Do not let children play with plastic bags, foils or small parts. There is a danger of swallowing or suffocating!**

- Original operating instructions
- Safety instructions

**3. Proper use**

The chain is designed exclusively for sawing wood. You may only fell trees if you have received the appropriate training. The manufacturer cannot be held liable for damage caused by improper or incorrect usage.

The equipment is to be used only for its prescribed purpose. Any other use is deemed to be a case of misuse. The user / operator and not the manufacturer will be liable for any damage or injuries of any kind caused as a result of this.

Please note that our equipment has not been designed for use in commercial, trade or industrial applications. Our warranty will be voided if the machine is used in commercial, trade or industrial businesses or for equivalent purposes.

**Caution! Residual risks**

Even if you use the equipment in accordance with the instructions, certain residual risks cannot be eliminated. The following hazards may arise in connection with the equipment's construction and layout:

1. Injuries through cutting in case of contact with the unguarded or rotating saw chain.
2. Injuries through cutting in case of kickback or other accidental movements of the guide rail.
3. Injuries due to parts of the saw chain being catapulted away.
4. Injuries due to parts of the cut material being catapulted away.
5. Damage to hearing if the compulsory hearing protection is not used.
6. Breathing problems due to the inhaling of harmful fumes and skin injuries due to contact with petrol.

**4. Technical data**

Engine displacement	50.4 cm <sup>3</sup>
Maximum engine capacity	2 kW
Cutting length	39 cm
Chain bar length	16" (40 cm)
Chain pitch	(3/8") 9.525 mm
Chain thickness	(0.05") 1.27 mm
Idling speed	3.000 ± 300 min <sup>-1</sup>
Maximum speed with cutting equipment	11,500 min <sup>-1</sup>
Max. chain speed	21 m/s
Tank capacity	540 cm <sup>3</sup>
Oil tank capacity	240 cm <sup>3</sup>
Anti-vibration function	Yes
Sprocket teeth	7 teeth x 9.525 mm
Net weight without chain and chain bar	5.75 kg
L <sub>PA</sub> sound pressure level (ISO 22868) at the operator's position	101.8 dB(A)
K <sub>PA</sub> uncertainty	2.5 dB(A)
L <sub>WA</sub> sound power level measured (ISO 22868)	111.5 dB(A)
K <sub>WA</sub> uncertainty	2.5 dB(A)
L <sub>WA</sub> sound power level guaranteed (ISO 2000/14/EC)	115 dB(A)
Vibration a <sub>hv</sub> (front handle) (ISO 22867)	max. 7.21 m/s <sup>2</sup>
Uncertainty K <sub>hv</sub>	1.5 m/s <sup>2</sup>
Vibration a <sub>hv</sub> (rear handle) (ISO 22867)	max. 6.53 m/s <sup>2</sup>
Uncertainty K <sub>hv</sub>	1.5 m/s <sup>2</sup>
Spark plug	TORCH L7RTC
Electrode gap	0.6 mm
Chain type	Kangxin ALP-50-57S
	Oregon 91PX057X
Bar type	Kangxin AP16-57-507P
	Oregon 160SDEA041

**Keep the noise emissions and vibrations to a minimum.**

- Only use appliances which are in perfect working order.
- Service and clean the appliance regularly.
- Adapt your working style to suit the appliance.
- Do not overload the appliance.
- Have the appliance serviced whenever necessary.
- Switch the appliance off when it is not in use.
- Wear protective gloves.

## 5. Before starting the equipment

**Danger:** Do not start the engine until the saw is fully assembled.

**Caution:** Wear protective gloves at all times when handling the chain.

### 5.1 Installing the guide rail and saw chain (Fig. 2A-2G)

1. Disengage the chain brake by pushing the front hand guard (6) towards the front handle (7). (Fig. 2A)
2. Remove the guide rail cover (A) by loosening the two nuts (19) (Fig. 2B).
3. Place the guide rail (2) into the mounting on the chainsaw (Fig. 2C).
4. Place the chain (3) around the drive wheel (C) (Fig. 2E). Check that the direction of rotation of the chain (3) is correct. The cutter links (B) must be aligned as shown in Fig. 2D.
5. Place the chain around the chain bar. (Fig. 2E)
6. The chain drive links (3) must slide fully into the groove which runs around the cutter bar (D) and also between the teeth on the drive wheel (C). (Fig. 2E)
7. Turn the chain tensioning screw (20) counterclockwise until the bolt (E) is at the end of its travel. (Fig. 1B/2F)
8. Install the bar cover (A).

**Important!** The bolt (E) on the chain tensioning mechanism must snap into place in the hole (G) in the guide rail. (Fig. 2G)

To ensure that happens, slide the guide rail (2) forwards and backwards slightly when you mount the bar cover (A). Hand tighten the nut (19).

### 5.2 Adjusting the chain tension (3A/3B)

Before adjusting the chain tension, make sure that the engine is switched off.

1. Push the tip of the guide rail (2) upwards slightly and adjust the chain tension using the chain tensioning screw (20). (Fig. 3A) The chain is set to the optimal tension when the chain (3) on the underside at the middle of the guide rail (2) is as shown in Fig. 3B (B).
2. Tighten the nut (19) while applying slight pressure to the tip of the bar.
3. Carry out a functional check. Pull the chain (3) by hand once all the way around the guide rail (2). If the chain (3) is hard to pull around the guide rail (2) or if it jams, the tension is too tight.

If that is the case, make the following slight adjustment:

1. Loosen the nut (19) and hand tighten it again.
2. Reduce the chain tension by turning the chain tensioning screw (20) counterclockwise. Only make small adjustments at a time and always pull the chain (3) backwards and forwards on the guide rail (2) to see if the chain (3) moves smoothly but still fits tightly.  
Note: If the chain (3) is too loose, turn the chain tensioning screw (20) clockwise.
3. If the chain tension is adjusted to the optimal setting, tighten the nut (19) while applying slight pressure to the tip of the bar.

**A new saw chain will stretch, so it is important to readjust the chain at short intervals (around 5 cuts) when you first start using it. The intervals get longer as operating time increases.**

**Note:** If the saw chain (3) is TOO LOOSE or TOO TAUT, the drive wheel, chain bar, chain and crank shaft bearing will suffer premature wear. Fig. 3B shows the correct tension A (when cold) and tension B (when warm). Fig. C shows a chain that is too loose.

### 5.3 Fuel and lubrication

#### Fuel

Use regular grade unleaded gasoline mixed with 1:40 custom 2-cycle engine oil for best results.

#### Mixing fuel

Mix fuel with 2 cycle oil in an approved container. Shake container to ensure thorough mix.

**Note:** Never use straight gasoline in your unit. This will cause permanent engine damage and void the manufacturer's warranty for that product. Never use a fuel mixture that has been stored for over 90 days.

**Note:** If 2-cycle lubricant is to be used, it must be a premium grade oil for 2-cycle air cooled engines mixed at a 1:40 ratio. Do not use any 2-cycle oil product with a recommended mixing ratio of 1:100. If insufficient lubrication is the cause of engine damage, it voids the manufacturer's engine warranty for that occurrence.

### Recommended fuels

Some conventional gasolines are being blended with oxygenates such as alcohol or an ether compound to meet clean air standards. Your engine is designed to operate satisfactorily on any gasoline intended for automotive use including oxygenated gasolines. It is recommended to use unleaded petrol as fuel.

### Lubrication of chain and chain bar

Whenever you refill the fuel tank with petrol you must also top up the level of chain oil in the chain oil tank. It is recommended to use standard chain oil.

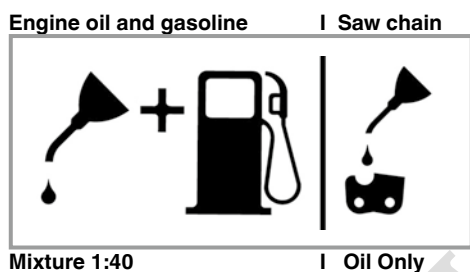

### Engine pre-start checks

**Danger:** Never start or operate the saw unless the bar and chain are properly installed.

1. Fill the fuel tank (21) with correct fuel mixture (Fig. 4).
2. Fill the oil tank (22) with chain oil (Fig. 4).

Once you have filled the chain and oil tank, tighten the tank cover securely by hand. Do not use any tools to do so.

## 6. Operation

Before you use the saw, check it for damage. If you discover any damage, do not use it. The chainsaw may be started only when the chain brake is engaged. The chain brake is engaged when the brake lever (6) is pushed forward.

**Explanation of how it works: refer to Checking the chain brake - Static check.**

### 6.1 Chain brake

The chainsaw is fitted with a chain brake which reduces the risk of injury caused by the danger of kickback. The brake is engaged when pressure is applied to the hand guard (6), e.g. when the hand of the person operating the chainsaw strikes the hand guard (6) if kickback occurs. When the brake is engaged, the chain (3) stops abruptly.

**Warning:** The chain brake is intended to reduce the risk of injury due to kickback; however, it is unable to provide adequate protection if the saw is used carelessly. You must check the operation of the chain brake on a regular basis. Test the chain brake before the first cut, after several cuts, after maintenance is done on the chainsaw and if the chainsaw has been subjected to strong impact or if it has been dropped.

#### 6.1.1 Checking the chain brake (Fig. 5A/5B/6)

##### Static check (engine switched off)

**Chain brake disengaged (chain (3) is free to move)**

1. Pull the front hand guard (6) towards the front handle (7). The front hand guard (6) must make an audible click when it snaps into place. (Fig. 5A)
2. It must be possible to move the chain (3) on the guide rail (2).

**Chain brake engaged (chain (3) is blocked)**

1. Push the front hand guard (6) towards the guide rail (2). The front hand guard (6) must make an audible click when it snaps into place. (Fig. 5B)
2. It must not be possible to move the chain (3) on the guide rail (2).

**Note:** The front hand guard (6) must snap into place in both positions. If you feel strong resistance or if the front hand guard (6) does not snap into place, do not use the chainsaw. Take your chainsaw to an authorized service center for repair.

##### Dynamic check (engine is started)

1. Place the saw on a firm and level surface.
2. Hold the front handle (7) with your left hand.
3. Start the chain saw by following the starting instructions. (refer to 6.2 and 6.3)
4. Disengage the chain brake (pull the front hand guard (6) towards the front handle (7)). (Fig. 5A)
5. Grasp the rear handle (8) with your right hand.

6. After a brief warmup period, run the engine at full speed. With the back of your left hand, push the front hand guard (6) towards the guide rail (2). This will engage the chain brake. (Fig. 6)

**Danger:** Engage the chain brake slowly and carefully. Hold the saw firmly with both hands, and make sure you have a good grip. The saw must not touch any objects.

7. The chain (3) must stop abruptly. Immediately release the throttle lever (11) when the chain (3) has come to a stop.

**Danger:** If the chain (3) does not stop, shut off the engine and take the saw to an authorized service center for repair.

#### 6.1.2 Checking the clutch

Carry out a functional check on the clutch on a regular basis. Test the clutch before the first cut, after several cuts, after maintenance is done on the chainsaw and if the chainsaw has been subjected to strong impact or if it has been dropped.

1. Start the chain saw by following the starting instructions. (refer to 6.2 and 6.3)
2. Briefly actuate the throttle lever (11) and release it to ensure that the throttle valve has been released and the engine is idling.
3. The chain (3) must stop when the engine is idling.

The clutch has been designed so that when the idling speed is increased by a factor of 1.25 no chain movement can be detected.

**Danger:** If the chain (3) does not stop, shut off the engine and take the saw to an authorized service center for repair.

**Danger:** Always engage the chain brake (6) before you start the engine.

#### 6.2 Starting a cold engine (Fig. 7A-7D)

Fill the tank with an adequate amount of gasoline/oil mix. (refer to Paragraph 5.3)

1. Set the equipment down on a hard, level surface.
2. Move the On/Off switch (10) to the „I“ position. (Fig. 7A)
3. Press the fuel pump (primer) (Fig. 6/Item 25) ten times.
4. Pull out the choke lever (13) (Fig. 7B)

**Note:** Pulling out the choke lever (13) opens the throttle valve slightly and locks it in that position. This increases the idle speed, and the saw starts faster.

5. Hold the saw firmly and pull out the starter handle (9) until you feel it start to resist. Then sharply pull the starter handle (9) 3 times. (Fig. 7C/7D)
6. Push in the choke lever (13).
7. Hold the saw firmly and pull out the starter handle (9) until you feel it start to resist. Then quickly pull the starter handle (9) several times until the engine starts. (Fig. 7D)

**Note:** Do not allow the starter handle (9) to snap back. This may result in damage. Once the engine has started, allow the saw to warm up for 10 seconds.

**Warning:** Since the throttle lever is slightly open, the cutter starts to operate when the engine is started. Briefly actuate the throttle lever (11). This releases the throttle valve and the engine returns to idle mode. (Fig. 7C)

8. If the engine does not start up after the starter handle is pulled 8 times, repeat steps 1-7.

Please note: If the engine does not start up even after several attempts, read the Engine troubleshooting section.

Please note: Always pull the starter handle out straight. If it is pulled out at an angle, friction will occur on the eyelet. As a result of this friction, the cable will become frayed and will wear faster. Always hold onto the starter handle when the cable retracts. Never allow the starter handle to snap back when it has been pulled out.

#### 6.3 Starting a warm engine (Fig. 7A-7D)

(The chainsaw has been idle for less than 15-20 min.)

1. Set the equipment down on a hard, level surface.
2. Move the On/Off switch (10) to the „I“ position. (Fig. 7A)
3. Hold the saw firmly and pull out the starter handle (9) until you feel it start to resist. Then quickly pull the starter handle (9) several times until the engine starts. The equipment should start after 1-2 tugs. If the saw does not start after 6 pulls, repeat steps 1 - 7 of Paragraph 6.2. (Fig. 7D)

#### 6.4 To stop engine

1. Release trigger and allow engine to return to idle speed.
2. Move STOP switch down to stop engine.

**Note:** To stop the engine in an emergency, activate the chain brake and switch the ON/OFF switch to "Stop (0)".

#### 6.5 General cutting instructions

**Danger:** Felling trees is prohibited without the necessary training!

##### Felling

- Felling is the term for cutting down a tree. Small trees up to 6-7 inches (15-18cm) in diameter are usually cut in a single cut. Larger trees require notch cuts. Notch cuts determine the direction the tree will fall.
- A retreat path (A) should be planned and cleared as necessary before cuts are started. The retreat path should extend back and diagonally to the rear of the expected line of fall, as illustrated in Fig. 8.
- If felling a tree on sloping ground, the chain saw operator should keep on the uphill side of the terrain, as the tree is likely to roll or slide downhill after it is felled.
- Direction of fall (B) is controlled by the notching cut. Before any cuts are made, consider the location of larger branches and natural lean of the tree to determine the way the tree will fall (Fig. 8).
- Do not cut down a tree during high or changing winds or if there is a danger to property. Consult a tree professional. Do not cut down a tree if there is a danger of striking utility wires; notify the utility company before making any cuts.

##### General guidelines for felling trees (Fig. 9)

Normally felling consists of 2 main cutting operations, notching (C) and making the felling cut (D).

- Start making the upper notch cut (C) on the side of the tree facing the felling direction (E). Be sure you don't make the lower cut too deep into the trunk. The notch (C) should be deep enough to create a hinge (F) of sufficient width and strength. The notch should be wide enough to direct the fall of the tree for as long as possible.
- Never walk in front of a tree that has been notched. Make the felling cut (D) from the other side of the tree and 1.5 - 2.0 inches

(3-5 cm) above the edge of the notch (C). Never saw completely through the trunk. Always leave a hinge. The hinge guides (F) the tree. If the trunk is completely cut through, control over the felling direction is lost. Insert a wedge or felling lever in the cut well before the tree becomes unstable and starts to move. This will prevent the guidebar from binding in the felling cut if you have misjudged the falling direction. Make sure no bystanders have entered the range of the falling tree before you push it over.

- Before making the final cut, always recheck the area for bystanders, animals or obstacles.

##### Felling cut

- Use wooden or plastic wedges (A) to prevent binding the bar or chain (B) in the cut. Wedges also control felling (Fig. 10).
- When diameter of wood being cut is greater than the bar length, make 2 cuts as shown (Fig. 11).
- As the felling cut gets close to the hinge, the tree should begin to fall. When tree begins to fall, remove saw from cut, stop engine, put chain saw down, and leave area along retreat path (Fig. 8).

##### Limbing

- Limbing a tree is the process of removing the branches from a fallen tree. Do not remove supporting limbs (A) until after the log is bucked (cut) into lengths (Fig. 12). Branches under tension should be cut from the bottom up to avoid binding the chain saw.
- Never cut tree limbs while standing on tree trunk.

##### Bucking

- Bucking is cutting a fallen log into lengths. Make sure you have a good footing and stand uphill of the log when cutting on sloping ground. If possible, the log should be supported so that the end to be cut off is not resting on the ground. If the log is supported at both ends and you must cut in the middle, make a downward cut halfway through the log and then make the undercut. This will prevent the log from pinching the bar and chain. Be careful that the chain does not cut into the ground when bucking as this causes rapid dulling of the chain. When bucking on a slope, always stand on the uphill side.

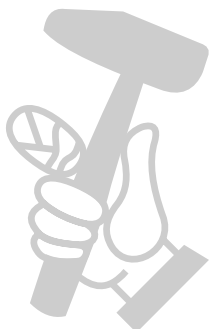

**1. Log supported along entire length:** Cut from top (overbuck), being careful to avoid cutting into the ground (Fig. 13A).

**2. Log supported on 1 end:** First, cut from bottom (underbuck) 1/3 diameter of log to avoid splintering. Second, cut from above (overbuck) to meet first cut and avoid pinching (Fig. 13B).

**3. Log supported on both ends:** First, overbuck 1/3 diameter of log to avoid splintering. Second, underbuck to meet first cut and avoid pinching (Fig. 13C).

- The best way to hold a log while bucking is to use a sawhorse. When this is not possible, the log should be raised and supported by the limb stumps or by using supporting logs. Be sure the log being cut is securely supported.

#### Bucking using a sawhorse (Fig. 14)

For personal safety and ease of cutting, the correct position for vertical bucking is essential.

- Hold the saw firmly with both hands and keep the saw to the right of your body while cutting.
- Keep the left arm as straight as possible.
- Keep weight on both feet.

**Caution:** When working with the saw, always make sure that the saw chain and chain bar are sufficiently lubricated.

## 7. Cleaning, maintenance, storage and ordering of spare parts

Disconnect the spark plug boot before doing any cleaning and maintenance work!

### 7.1 Cleaning

- Keep all safety devices, air vents and the motor housing free of dirt and dust as far as possible. Wipe the equipment with a clean cloth or blow it with compressed air at low pressure.
- We recommend that you clean the device immediately each time you have finished using it.
- Clean the equipment regularly with a moist cloth and some soft soap. Do not use cleaning agents or solvents; these could attack the plastic parts of the equipment. Ensure that no water can seep into the device.

### 7.2 Maintenance

**Warning:** All maintenance work on the chainsaw apart from the work described in this manual may only be carried out by authorized after-sales service personnel.

#### 7.2.1 Air filter

**Note:** Never operate saw without the air filter. Dust and dirt will be drawn into engine and damage it. Keep the air filter clean! The air filter must be cleaned or replaced after every 20 hours of service.

#### Cleaning the air filter (Fig. 15A/15B)

1. Remove the top cover (14) by undoing the cover fastening screw (A) on the cover. You can then remove the cover (Fig. 15A).
2. Lift out the air filter (15) (Fig. 15B).
3. Clean air filter. Wash filter in clean, warm, soapy water. Rinse in clear, cool water. Air dry completely.

**Note:** It is advisable to have a supply of spare filters.

4. Insert the air filter. Install the air filter cover (14). Make sure that the cover fits perfectly when you do so. Tighten the cover fastening screw.

#### 7.2.2 Fuel filter

**Note:** Never use the saw without a fuel filter. After 100 hours in operation the fuel filter should be cleaned or, in case of damage, replaced. Be sure to empty the fuel tank before changing the filter.

1. Remove the fuel tank cap.
2. Bend a piece of soft wire.
3. Reach into fuel tank opening and hook fuel line. Carefully pull the fuel line toward the opening until you can reach it with your fingers.

**Note:** Do not pull hose completely out of tank.

4. Lift filter out of tank .
5. Pull off the filter with a twist and clean it; if the filter is damaged, dispose of it.
6. Insert a new filter. Place one end of the filter into the tank opening. Make sure that the filter is seated in the lower corner of the tank. If necessary, use a long screwdriver to move the filter to its correct position, taking care not to damage in the process.
7. Fill tank with fresh fuel / oil mixture. See Section Fuel and Lubrication. Install fuel cap.

### 7.2.3 Spark plug (Fig. 15A-15C)

**Note:** To ensure that the saw's engine retains its power, the spark plug must be clean and have the correct electrode gap (0.6 mm). The spark plug must be cleaned or replaced after every 20 hours of service.

1. Set the On/Off switch to Stop (0)".
2. Remove the top cover (14) by undoing the cover fastening screw (A) on the cover. You can then remove the cover (Fig. 15A).
3. Lift out the air filter (15) (Fig. 15B).
4. Disconnect the ignition cable (C) from the spark plug by pulling and twisting it simultaneously (Fig. 15C).
5. Remove the spark plug using a spark plug wrench.
6. Clean the spark plug with a copper wire brush or fit a new one.

### 7.2.4 Carburetor setting

The carburetor has been set to its perfect adjustment at the factory. If it requires adjusting, take the saw to your nearest authorized after-sales service outlet.

### 7.2.5 Chain bar

- Grease the guide rail starwheel after every 10 hours of operation. This is necessary to get the best performance from your chainsaw. (Fig. 16) Clean the lube hole, then place the lube gun (not included) at the hole and pump grease into the bearing until grease is forced out.
- Clean the groove which the chain runs in as well as the oil entry hole on a regular basis using a commercially available cleaning tool. (Fig. 17A) This is important to ensure optimal lubrication of the guide rail and chain during operation.
- Remove burrs and sharp edges on the guide rail (2) by carefully filing them down with a flat file. (Fig. 17B)
- Turn the guide rail (2) around after every 8 hours of operation so that it wears evenly on the top and bottom.

### Oil passages

Oil passages on the bar should be cleaned to ensure proper lubrication of the bar and chain during operation.

**Note:** The condition of the oil passages can be easily checked. If the passages are clear, the chain will automatically give off a spray of oil within seconds of starting the saw. Your saw is equipped with an automatic oiler system.

### Automatic chain lubrication.

The chain saw is equipped with an automatic oil lubrication system with a toothed wheel drive. It automatically supplies the bar and the chain with the right quantity of oil. The moment the engine is accelerated, the oil also starts to flow through the bar plate more quickly as well.

The chain lubrication system has been set to its perfect adjustment at the factory. If it requires adjusting, take the saw to your nearest authorized after-sales service outlet.

On the underside of the chainsaw you will find the setting screw (A) for the chain lubrication system (Fig. 21). Turning the screw counter-clockwise increases the chain lubrication, turning it clockwise decreases the chain lubrication.

To check the chain lubrication, hold the chain saw, with the chain, over a piece of paper and run it at full speed for a few seconds. You will be able to judge the set amount of oil from the paper.

On a regular basis, check that the chain lubrication is working correctly. Test chain lubrication before the first cut, after several cuts and always after any maintenance.

### Chain lubrication

Always make sure the automatic oiler system is working properly. Keep the oil tank filled with Chain, Bar and Sprocket Oil.

Adequate lubrication of the bar and chain during cutting operations is essential to minimize friction with the guide bar.

Never starve the bar and chain of lubricating oil. Running the saw dry or with too little oil will decrease cutting efficiency, shorten saw chain life, cause rapid dulling of chain, and lead to excessive wear of bar from overheating. Too little oil is evidenced by smoke or bar discoloration.

### 7.2.6 Chain maintenance

#### Chain sharpening

**Note:** A sharp chain produces well-defined chips. When your chain starts to produce sawdust, it is time to sharpen.

Chain sharpening requires special tools to ensure that cutters are sharpened at the correct angle and depth. For the inexperienced chain saw user, we recommend that the saw chain be professionally sharpened by the nearest professional Service Center. If you feel comfortable sharpening your own saw chain, special tools are available from the professional Service Center.

#### Chain sharpening (Fig. 18)

Sharpen the chain using protective gloves and a round file of.

Always sharpen the cutters only with outward strokes (Fig. 19) observing the values given in Fig. 18.

After sharpening, the cutting links must all have the same width and length.

After the blades have been sharpened 3-4 times, check the height of the depth limiter and if necessary lower it with a flat file and then round off the front corner (Fig. 20).

Round off the front edges with a file.

### 7.3 Storage and transportation

Install the chain guard (4) before transporting or storing the chainsaw.

**Note:** Never put a chain saw into storage for longer than 30 days without carrying out the following steps.

#### Storing a chain saw

Storing a chain saw for longer than 30 days requires storage maintenance. Unless the storage instructions are followed, fuel remaining in the carburetor will evaporate, leaving gum-like deposits. This could lead to difficult starting and result in costly repairs.

1. Remove the fuel tank cap slowly to release any pressure in tank. Carefully drain the fuel tank.
2. Start the engine and let it run until the unit stops to remove fuel from carburetor.
3. Allow the engine to cool (approx. 5 minutes).
4. Thoroughly clean the saw.

**Note:** Store the unit in a dry place and away from possible sources of ignition such as a furnace, gas hot water heater, gas dryer, etc.

After the saw has been in storage, perform the steps listed in Paragraph 5 before starting the chainsaw.

#### Transportation

- Engage the chain brake.
- Make sure the chainsaw cannot shift position in order to prevent fuel loss, damage or injury.

### 7.4 Ordering replacement parts:

Please quote the following data when ordering replacement parts:

- Type of machine
- Article number of the machine
- Identification number of the machine
- Replacement part number of the part required

For our latest prices and information please go to [www.Einhell-Service.com](http://www.Einhell-Service.com)

## 8. Disposal and recycling

The equipment is supplied in packaging to prevent it from being damaged in transit. The raw materials in this packaging can be reused or recycled. The equipment and its accessories are made of various types of material, such as metal and plastic. Never place defective equipment in your household refuse. The equipment should be taken to a suitable collection center for proper disposal. If you do not know the whereabouts of such a collection point, you should ask in your local council offices.

## 9. Troubleshooting guide

Problem	Probable cause	Corrective Action
Unit won't start or starts but will not run.	<ul style="list-style-type: none"> <li>- Incorrect starting procedures.</li> <li>- Too much fuel in the combustion chamber following failed attempts to start the saw.</li> <li>- Incorrect carburetor mixture adjustment setting.</li> <li>- Fouled spark plug.</li> <li>- Fuel filter plugged.</li> </ul>	<ul style="list-style-type: none"> <li>- Follow instructions in the User Manual.</li> <li>- Wait about 30 minutes until the fuel in the combustion chamber has evaporated before trying again to start the chainsaw.</li> <li>- Have carburetor adjusted by an Authorized Service Center.</li> <li>- Clean / gap or replace plug.</li> <li>- Replace fuel filter.</li> </ul>
Unit starts, but engine has low power.	<ul style="list-style-type: none"> <li>- Incorrect lever position on choke.</li> <li>- Dirty air filter.</li> <li>- Incorrect carburetor mixture adjustment setting.</li> </ul>	<ul style="list-style-type: none"> <li>- Move the lever to the correct position.</li> <li>- Remove, clean and reinstall filter.</li> <li>- Have carburetor adjusted by an Authorized Service Center.</li> </ul>
Engine hesitates.	<ul style="list-style-type: none"> <li>- Incorrect carburetor mixture adjustment setting.</li> </ul>	<ul style="list-style-type: none"> <li>- Have carburetor adjusted by an Authorized Service Center.</li> </ul>
No power under load.	<ul style="list-style-type: none"> <li>- Incorrectly gapped spark plug.</li> </ul>	<ul style="list-style-type: none"> <li>- Clean / gap or replace plug.</li> </ul>
Runs erratically.	<ul style="list-style-type: none"> <li>- Incorrect carburetor mixture adjustment setting.</li> </ul>	<ul style="list-style-type: none"> <li>- Have carburetor adjusted by an Authorized Service Center.</li> </ul>
Smokes excessively.	<ul style="list-style-type: none"> <li>- Incorrect fuel mixture.</li> </ul>	<ul style="list-style-type: none"> <li>- Use properly mixed fuel (40:1 mixture).</li> </ul>
Poor performance when operated	<ul style="list-style-type: none"> <li>- Blunt chain</li> <li>- Loose chain</li> </ul>	<ul style="list-style-type: none"> <li>- Sharpen or replace the chain</li> <li>- Tension the chain</li> </ul>
Engine dies	<ul style="list-style-type: none"> <li>- Empty petrol tank</li> <li>- Fuel filter in the wrong position in the tank</li> </ul>	<ul style="list-style-type: none"> <li>- Fill up the petrol tank</li> <li>- Completely fill the petrol tank or re-position the fuel filter in the petrol tank</li> </ul>
Insufficient chain lubrication (the cutter rail and chain get hot)	<ul style="list-style-type: none"> <li>- Empty oil tank for the chain</li> <li>- Oil lubrication openings moved</li> </ul>	<ul style="list-style-type: none"> <li>- Top up the oil tank for the chain</li> <li>- Clean the oil entry hole/groove on the guide rail.</li> </ul>

The reprinting or reproduction by any other means, in whole or in part, of documentation and papers accompanying products is permitted only with the express consent of the Einhell Germany AG.

Subject to technical changes

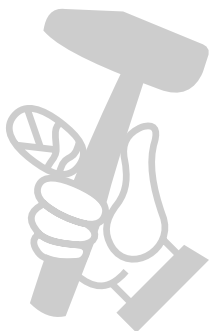

## Service information

We have competent service partners in all countries named on the guarantee certificate whose contact details can also be found on the guarantee certificate. These partners will help you with all service requests such as repairs, spare and wearing part orders or the purchase of consumables.

Please note that the following parts of this product are subject to normal or natural wear and that the following parts are therefore also required for use as consumables.

Category	Example
Wear parts*	Cutter bar, spark plug, air filter, petrol filter
Consumables*	Saw chain
Missing parts	

\* Not necessarily included in the scope of delivery!

In the event of defects or faults, please register the problem on the internet at [www.Einhell-Service.com](http://www.Einhell-Service.com). Please ensure that you provide a precise description of the problem and answer the following questions in all cases:

- Did the equipment work at all or was it defective from the beginning?
- Did you notice anything (symptom or defect) prior to the failure?
- What malfunction does the equipment have in your opinion (main symptom)? Describe this malfunction.

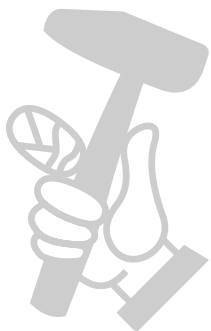

## Warranty certificate

Dear Customer,

All of our products undergo strict quality checks to ensure that they reach you in perfect condition. In the unlikely event that this equipment develops a fault, please contact our service department at the address shown on this guarantee card. You can also contact us by telephone using the service number shown. Please note the following terms under which guarantee claims can be made:

1. These guarantee terms apply solely to consumers, i.e. natural persons, who do not want to use this product in connection with either their commercial or other self-employed activities. These guarantee terms regulate additional guarantee services which the undermentioned manufacturer promises to buyers of its new products in addition to their statutory rights of guarantee. Your statutory rights of guarantee are not affected by this guarantee. Our guarantee is free of charge to you.
2. The guarantee services cover only defects due to material or manufacturing faults on the new product which you have bought in the European Union from the undermentioned manufacturer and are limited to either the rectification of said defects or the replacement of the product, whichever we prefer. Please note that only equipment under the brand name "Professional" has been designed for use in commercial, trade or professional applications. For all other products the guarantee is invalidated if the equipment is used within the guarantee period in commercial, trade or industrial applications or for other equivalent activities.
3. Our guarantee does not cover:
  - Damage to the equipment caused by failure to comply with the installation/assembly instructions or by unprofessional installation; damage caused by failure to comply with the operating instructions (e.g. connection to the wrong mains voltage or current type); damage caused by failure to comply with the maintenance and safety regulations; damage caused by exposing the equipment to abnormal environmental conditions; damage resulting from poor care and maintenance.
  - Damage to the equipment caused by misuse or incorrect applications (e.g. overloading the equipment or using non-approved attachments or accessories); damage caused by foreign bodies (e.g. sand, stones, dust, ...) getting inside the equipment. Damage in transit; damage caused by force or external influences (e.g. by dropping the equipment).
  - Damage to the equipment or parts of the equipment which is owed to use-related, normal or otherwise natural wear. For example, batteries and battery packs are manufactured with a cycle limit for design-related reasons. Wear is negatively influenced in particular by load demands and charging speeds as well as exposure to heat, cold, vibration and impact.
4. The guarantee is valid for a period of 2 years starting from the purchase date of the equipment. Guarantee claims must be submitted before the end of the guarantee period and within two weeks of the defect being noticed. No guarantee claims will be accepted after the end of the guarantee period. The original guarantee period remains applicable to the equipment even if repairs are carried out or parts are replaced. In such cases, the work performed or parts fitted will not result in an extension of the guarantee period, and no new guarantee will become active for the work performed or for any replacement parts fitted. This also applies if on-site service is used.
5. To assert your guarantee claim, register the defective equipment at: [www.Einhell-Service.com](http://www.Einhell-Service.com). You will need to provide proof of purchase of the new item of equipment. Equipment returned without such proof or without a rating plate are excluded from the guarantee services because of the lack of traceability. If the defect is covered by our guarantee, then either the item in question will be repaired immediately and returned to you or we will send you a new replacement.
6. If you have taken the equipment with you to a different EU country than where you bought it, we will arrange for a local service partner to provide the guarantee services. If you take the equipment outside the EU, the guarantee will not apply.

Of course, we are also happy to offer a chargeable repair service for any defects which are not covered or no longer covered by the scope of this guarantee. To take advantage of this service, please send the equipment to our service address. We draw attention to the restrictions of this guarantee concerning wear parts, consumables and missing parts as presented in the service information included in this operating manual.

Warrantor/ Service:

Einhell UK Ltd, Unit 10, 1st Floor, Champion's Business Park, Arrove Brook Road, Upton, Wirral, CH49 0UQ