



GC-BC 52 I AS

D	Originalbetriebsanleitung Benzin-Motorsense	NL	Originele handleiding Benzinemotorzeis
GB	Original operating instructions Petrol Power Scythe	E	Manual de instrucciones original Desbrozadora con motor de gasolina
F	Instructions d'origine Débroussailleuse à moteur à essence	FIN	Alkuperäiskäyttöohje Bensiinikäyttöinen moottoriviikate
I	Istruzioni per l'uso originali Decespugliatore a motore a benzina	RUS	Оригинальное руководство по эксплуатации Бензиновая мотокосилка
DK/ N	Original betjeningsvejledning Benzindrevet motorle	RO	Instrucțiuni de utilizare originale Motocoasă pe benzină
S	Original-bruksanvisning Bensindriven röjsåg		



Art.-Nr.: 34.365.40

I.-Nr.: 11029

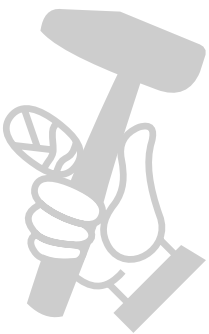

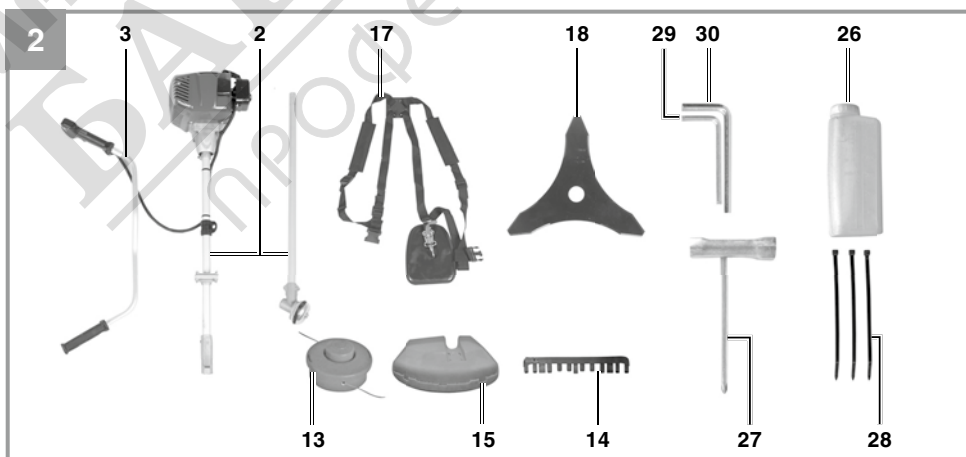

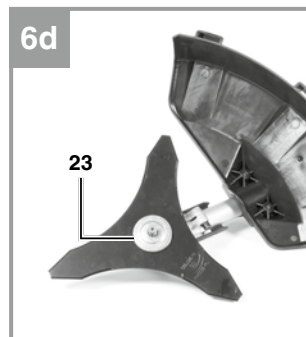
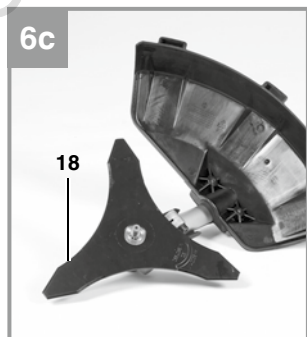
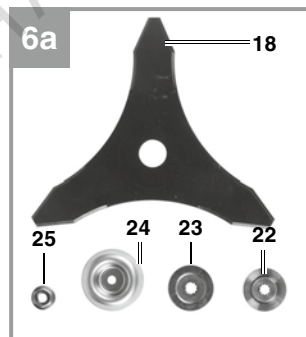
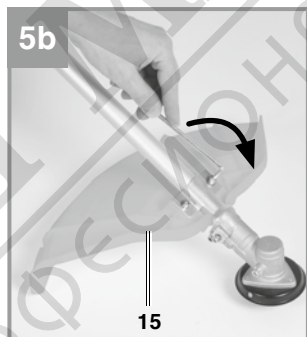
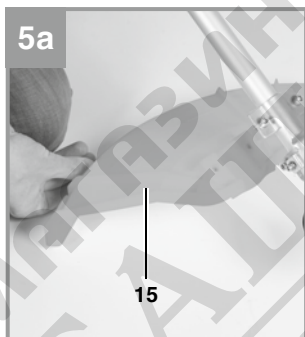
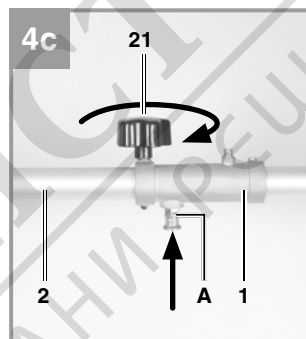
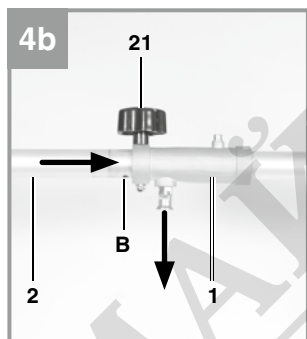
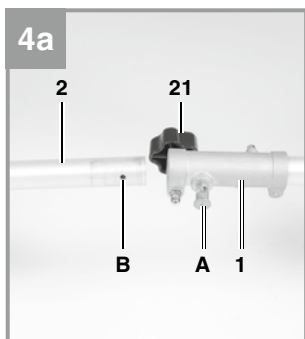
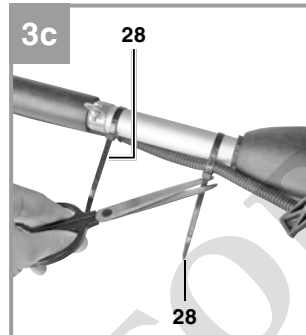
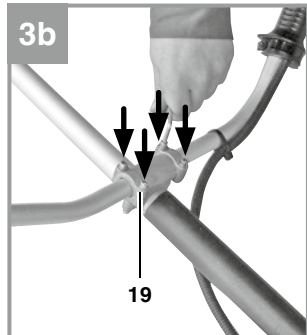
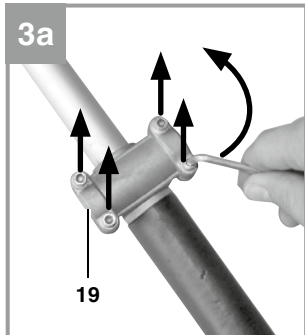

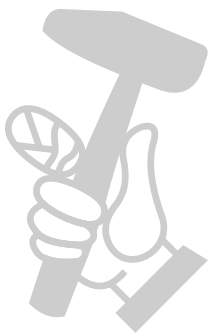
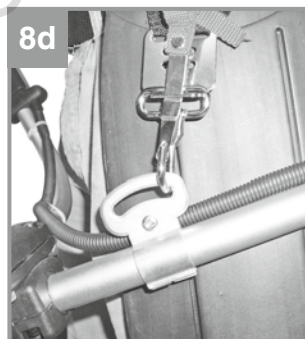
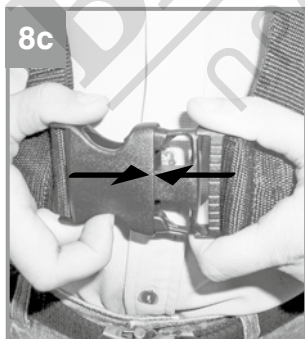
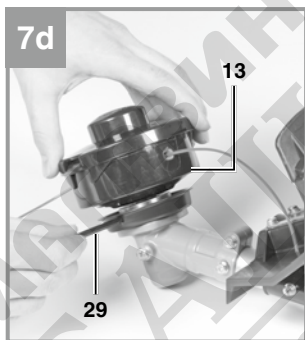
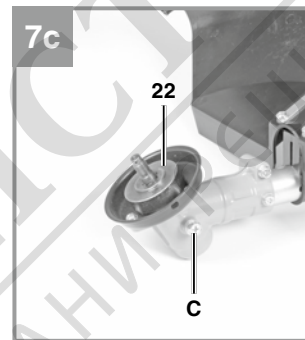
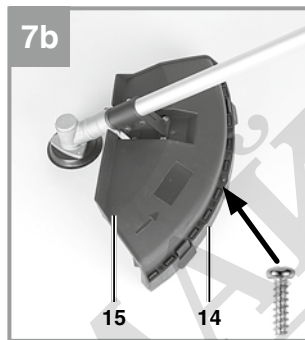
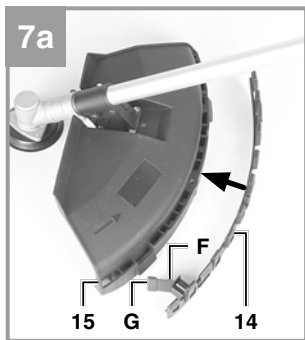
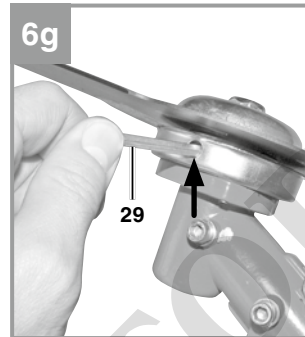
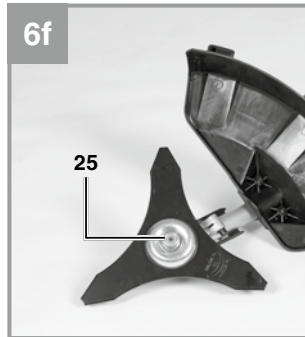
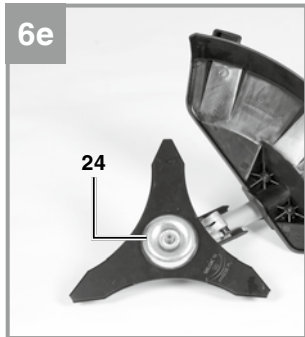

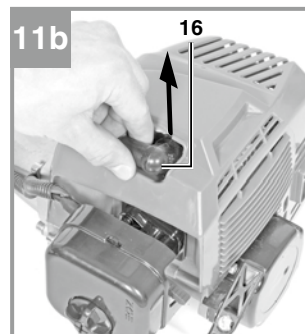
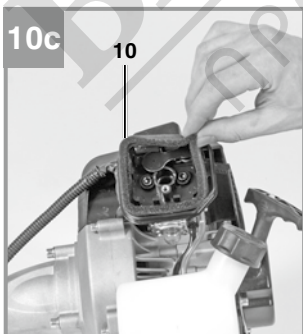
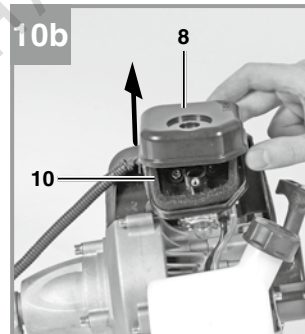
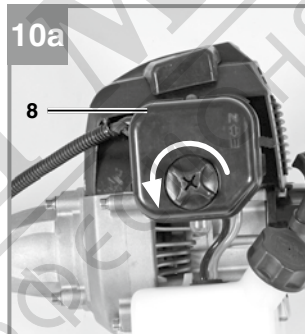
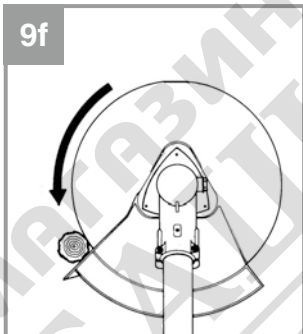
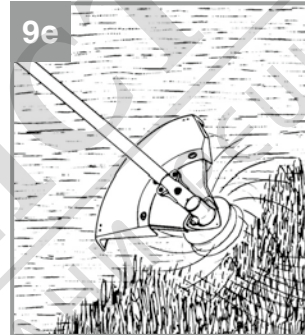
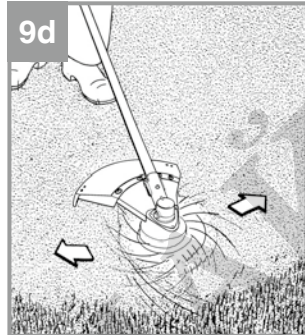
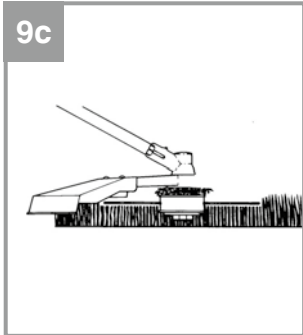
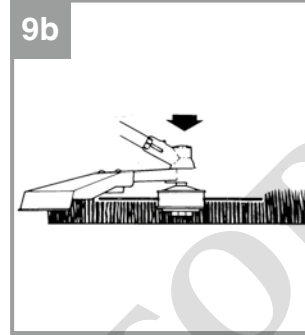
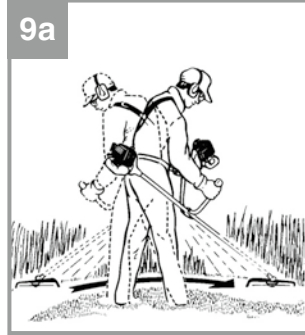

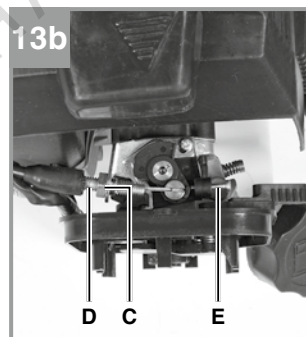
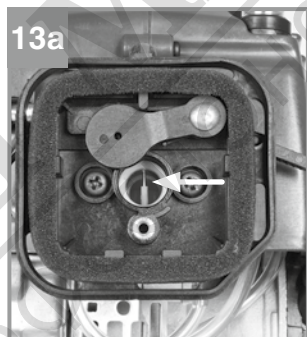
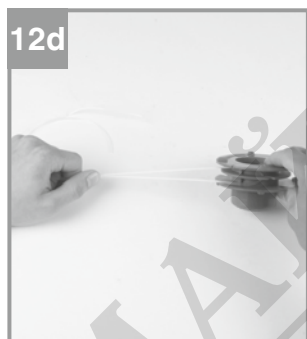
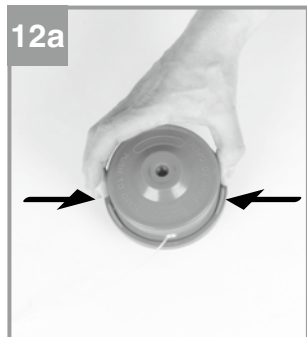

Danger!

When using the equipment, a few safety precautions must be observed to avoid injuries and damage. Please read the complete operating instructions and safety regulations with due care. Keep this manual in a safe place, so that the information is available at all times. If you give the equipment to any other person, hand over these operating instructions and safety regulations as well. We cannot accept any liability for damage or accidents which arise due to a failure to follow these instructions and the safety instructions.

1. Safety regulations

The corresponding safety information can be found in the enclosed booklet.

Danger!**Read all safety regulations and instructions.**

Any errors made in following the safety regulations and instructions may result in an electric shock, fire and/or serious injury.

Keep all safety regulations and instructions in a safe place for future use.**Safety devices**

When working with the equipment, the appropriate plastic guard hood for cutting blade mode or cutting line mode must be fitted to prevent objects being thrown out by the equipment. The integrated blade in the cutting line guard hood automatically cuts the line to the optimum length.

Explanation of the warning signs on the equipment (Fig. 14):

1. Warning!
2. Read the directions for use before operating the equipment.
3. Wear protective headgear, goggles and ear muffs.
4. Wear sturdy, non-slip footwear.
5. Wear safety gloves.
6. Protect the equipment from rain and damp.
7. Be careful of objects being thrown out!
8. Always switch off the equipment and pull out the spark boot plug before carrying out any maintenance work.
9. All bystanders must be kept at least 15 m from the machine.
10. The equipment continues to rotate!
11. Caution: Hot equipment parts. Keep your distance.

12. Add a little grease (gear grease) after every 20 hours in operation!
13. Beware of recoil!
14. Do not use any saw blades.

2. Layout and items supplied**2.1 Layout (Fig. 1-13)**

1. Guide pin adapter
2. Guide pin
3. Operating handle
4. Starter cable
5. Choke lever
6. Gas tank
7. Fuel pump (primer)
8. Air filter housing cover
9. ON-OFF switch
10. Air filter
11. Throttle lever
12. Throttle lock
13. Line spool with cutting line
14. Cutting line guard hood
15. Cutting blade guard hood
16. Spark plug connector
17. Harness
18. Cutting blade
19. Holder for steady grip
20. Spark plug connector cover
21. Handle screw M6
22. Carrier plate
23. Pressure plate
24. Pressure plate cover
25. Nut M10 (left-hand thread)
26. Oil/petrol mixing bottle
27. Spark plug wrench
28. 3x cable tie
29. Allen key 4 mm
30. Allen key 5 mm

2.2 Items supplied

Please check that the article is complete as specified in the scope of delivery. If parts are missing, please contact our service center or the sales outlet where you made your purchase at the latest within 5 working days after purchasing the product and upon presentation of a valid bill of purchase. Also, refer to the warranty table in the service information at the end of the operating instructions.

- Open the packaging and take out the equipment with care.
- Remove the packaging material and any packaging and/or transportation braces (if

- available).
- Check to see if all items are supplied.
- Inspect the equipment and accessories for transport damage.
- If possible, please keep the packaging until the end of the guarantee period.

Danger!

The equipment and packaging material are not toys. Do not let children play with plastic bags, foils or small parts. There is a danger of swallowing or suffocating!

- Petrol scythe mower
- Guide pin
- Operating handle
- Operating handle retainer
- Carrying strap
- Trimming blade
- Spool with nylon line
- Driving plate
- Pressure plate
- Pressure plate cover
- Nut M10 (left-hand thread)
- Combined oil/petrol cylinder
- Spark plug wrench
- Allen wrench 4 mm
- Allen wrench 5 mm
- 3 ea. tie wraps
- Knurled screw M6
- Protective hood for nylon line/trimming blade
- Original operating instructions
- Safety instructions

3. Proper use

The power scythe (using the cutting blade) is designed for cutting young trees, strong weeds and undergrowth. The power trimmer (using the line spool with cutting line) is designed for cutting lawns, grassed areas and small weeds. The operating instructions as supplied by the manufacturer must be obeyed to ensure that the equipment is used properly. Any use which is not expressly permitted in the manual may result in damage to the equipment and place the user in serious danger. Be sure to observe the restrictions in the safety instructions.

Please note that our equipment has not been designed for use in commercial, trade or industrial applications. Our warranty will be voided if the equipment is used in commercial, trade or industrial

businesses or for equivalent purposes.

Important. Due to the high risk of bodily injury to the user, the petrol power scythe must not be used to carry out the following work: to clean dirt and debris off walkways, or to chop up tree or hedge clippings. Similarly, the petrol power scythe must not be used to level out high areas such as molehills. For safety reasons, the petrol power scythe must not be used as a drive unit for other work tools or toolkits of any kind.

The equipment is allowed to be used only for its prescribed purpose. Any other use is deemed to be a case of misuse. The user/operator and not the manufacturer will be liable for any damage or injuries of any kind resulting from such misuse.

4. Technical data

Engine type	2-stroke engine, air-cooled, chrome cylinder
Engine power (max.)	1.5 kW (2 HP)
Displacement	51.7 ccm
Idle speed of engine	3000 ± 300 min ⁻¹
Max. engine speed	9600 min ⁻¹
Max. torque	
Scythe:	6750 min ⁻¹
Trimmer:	6000 min ⁻¹
Ignition	Digital
Drive	Centrifugal clutch
Weight (with empty tank)	7.4 kg
Cutting line diameter	42 cm
Cutting circle diameter of blade	25.5 cm
Cutting line length	4 m
Cutting line diameter:	2.4 mm
Tank capacity	0.9 l
Spark plug	L8RTC

Danger!

Sound and vibration

L _{PA} sound pressure level	95.8 dB(A)
K _{PA} uncertainty	3 dB
L _{WA} sound power level	114 dB(A)
K _{WA} uncertainty	3 dB

Wear ear-muffs.

The impact of noise can cause damage to hearing.

Functions

Vibration emission value $a_h = 7.02 \text{ m/s}^2$

K uncertainty = 1.5 m/s^2

Keep the noise emissions and vibrations to a minimum.

- Only use appliances which are in perfect working order.
- Service and clean the appliance regularly.
- Adapt your working style to suit the appliance.
- Do not overload the appliance.
- Have the appliance serviced whenever necessary.
- Switch the appliance off when it is not in use.
- Wear protective gloves.

5. Assembly

5.1.1 Fitting the steady grip

Install the steady grip as shown in Figures 3a-3c. Do not tighten the screws until you have set the perfect working position with the carrying strap. The steady grip should be aligned as shown in Figure 1. To dismantle, proceed in reverse order.

5.1.2 Fitting the long handle (Fig. 4a – 4c)

Pull the locking lever (A) and push the long handle (Fig. 4b/Item 2) carefully into the connecting piece of the long handle. While doing so, make sure that the drive shafts on the inside of the long handle slide into each other (turn the spool head slightly if required). The lug of the locking lever (A) must latch into the hole (B). Now tighten the handle screw (21) as shown in Figure 4c.

5.1.3 Fitting the blade guard hood

Important: The cutting blade guard hood must be fitted if you wish to work with the cutting blade. The guard hood for the cutting blade must be installed as shown in Figures 5a – 5b.

5.1.4 Fitting/Replacing the cutting blade

The fitting of the cutting blade is shown in Figures 6a – 6g. To dismantle, proceed in reverse order.

- Fit the carrier plate (22) onto the spline shaft (Fig. 6b)
- Securely fit the cutting blade (18) on the cover ring (Fig. 6c)
- Place the pressure plate (23) over the thread of the spline shaft (Fig. 6d).
- Plug on the cover of the pressure plate (24) (Fig. 6e).
- Look for the hole in the carrier plate, line up

with the notch underneath, lock with the supplied Allen key (29), and tighten the nut (25) (Fig. 6f/6g). Important: Left-hand thread

5.1.5 Fitting the cutting line guard hood to the blade guard hood

Important: The cutting line guard hood must be additionally fitted if you want to work with the cutting line (Fig. 7a/Item 14).

The guard hood for the cutting line must be installed as shown in Figures 7a – 7b. A blade (Fig. 7a/ Item F) on the underside of the guard hood automatically cuts the cutting line to the optimum length. This is covered by a guard (Fig. 7a/Item G).

Remove the guard before you start working and replace it when you have finished working.

5.1.6 Fitting/Replacing the line spool

The procedure for fitting the line spool is shown in Figures 7c-7d. To dismantle, proceed in reverse order.

Look for the hole in the carrier plate, line up with the notch beneath it, lock with the supplied Allen key (29), and screw the line spool onto the thread. Important: Left-hand thread

5.2 Setting the cutting height

- Fit the carrying strap as shown in Figures 8a-8c.
- Hook the equipment to the carrying belt (Fig. 8d).
- Adjust the perfect working and cutting position using the various strap adjusters on the carrying strap (Fig. 8e).
- In order to establish the optimum length of the carrying strap, you should then make a few swinging movements without starting the engine (Fig. 9a).

The carrying strap is fitted with a quick-release mechanism. Pull the red strap section (Fig. 8f) if you need to remove the strap quickly.

Important: Always use the strap when working with the equipment. Attach the strap as soon as you have started the engine and it is running in idle mode. Switch off the engine before you take off the carrying strap.

6. Before starting the equipment

Check the equipment for the following each time before use:

- That there are no leaks in the fuel system.
- That the equipment is in perfect condition and that the safety devices and cutting devices are complete.
- That all screws are securely fastened.
- That all moving parts move smoothly.

6.1 Fuel and oil

Recommended fuels

Use only a mixture of unleaded petrol and special 2-stroke engine oil. Mix the fuel mixture as indicated on the fuel mixing table.

Important: Do not use a fuel mixture which has been stored for longer than 90 days.

Important: Never use 2-stroke oil with a recommended mixing ratio of 100:1. The manufacturer's warranty will be voided in case of engine damage due to inadequate lubrication.

Important: Only use containers designed and approved for the purpose to transport and store fuel. Pour the correct quantities of petrol and 2-stroke oil into the mixing bottle (see scale printed on the bottle). Then shake the bottle well.

6.2 Fuel mixture table

Mixing procedure: 40 parts petrol to 1 part oil

Petrol	2-stroke oil
1 liter	25 ml
5 liters	125 ml

7. Operation

Please note that the statutory regulations governing noise abatement may differ from town to town.

Before starting up the equipment remove the protective caps from the cutting blade.

7.1 Starting the engine when cold

Fill the tank with the required amount of oil/petrol mix. See "Fuel and oil".

1. Set the equipment down on a hard, level surface.
2. Press the fuel pump (primer) (Fig. 1/Item 7) 10 times.
3. Move the ON/OFF switch (Fig. 1/Item 9) to "I".
4. Set the choke lever (Fig. 1/Item 5) to „I“.
5. Hold the equipment firmly and pull out the

starter cable (Fig. 1/Item 4) until you feel it start to resist. Then tug sharply on the starter cable 2 times.

6. Set the choke lever (Fig. 1/Item 5) to „I“.
7. Hold the equipment firmly and pull out the starter cable (Fig. 1/Item 4) until you feel it start to resist. Then tug sharply on the starter cable 4 times. The equipment should start. Important: Never allow the starter cable to snap back. This may damage the equipment. Once the engine has started, allow the equipment to warm up for 10 seconds. Important: The cutting tool starts to operate when the engine is started.
8. If the engine does not start up, repeat steps 4-8 above.

Please note: If the engine does not start up even after several attempts, read the section "Engine Troubleshooting". Please note: Always pull the starter cord out in a straight line. If it is pulled out at an angle, then friction will occur on the eyelet. As a result of this friction, the cable will become frayed and will wear away faster. Always hold the starter handle when the cable retracts. Never allow the cable to snap back when it has been pulled out.

7.2 Starting the engine when warm

(The equipment has been idle for less than 15-20 min.)

1. Set the equipment down on a hard, level surface.
2. Switch the ON/OFF switch to "I".
3. Hold the equipment firmly and pull out the starter cable until you feel it start to resist. Then tug sharply on the starter cable. The equipment should start after 1-2 tugs. If the equipment does not start after 6 pulls, repeat steps 1 – 7 of the procedure for starting the engine from cold.

7.3 Switching off the engine

Emergency Stop procedure:

If it becomes necessary to stop the equipment immediately, set the ON/OFF switch to "Stop" or "0".

Normal procedure:

Let go of the throttle lever and wait until the engine has changed to idling speed. Then set the ON/OFF switch to "Stop" or "0".

7.4 Practical tips

Practice all operating techniques with the engine switched off before you start to use the equipment.

8. Working with the petrol power scythe

Extending the cutting line

Caution! Do not use any kind of metal wire or metal wire encased in plastic in the line spool. This may cause serious injuries to the user. To extend the cutting line, run the engine at full speed and tap the line spool on the ground. This will automatically extend the line. The blade on the safety shield will cut the line to the appropriate length (Fig. 9b).

Important: Remove all grass and weed remnants at regular intervals to prevent the shaft tube overheating. Lawn, grass and weed remnants become trapped under the safety shield (Fig. 9c) and prevent the shaft tube from receiving adequate ventilation. Remove the remnants carefully using a screwdriver or the like.

Different cutting methods

When the equipment is correctly assembled it will cut weeds and long grass in places which are difficult to access, e.g. along fences, walls and foundations and also around trees. It can also be used for „mowing“ down vegetation so that a garden can be better prepared or a certain area cleared down to the soil.

Please note: Even if it is used carefully, cutting around foundations, stone or concrete walls, etc. will result in the line suffering more than normal wear.

Trimming/mowing

Swing the trimmer from side to side in a scything motion. Always keep the line spool parallel to the ground. Check the site and decide which cutting height you require. Guide and hold the line spool at the required height to obtain an even cut (Fig. 9d).

Low trimming

Hold the trimmer right in front of you at a slight angle so that the underside of the line spool is above the ground and the line strikes the correct target. Always cut away from yourself. Never draw

the trimmer towards yourself.

Cutting along fences/foundations

Approach wire mesh fences, lath fences, natural stone walls and foundations slowly so that you can cut close to them without striking the obstacle with the line. If, for example, the line strikes stones, stone walls or foundations, it will wear or fray.

If the line strikes wire fencing, it will break.

Trimming around trees

When trimming around tree trunks, approach slowly so that the line does not strike the bark. Walk around the tree, cutting from left to right. Approach grass or weeds with the tip of the line and tilt the line spool forwards slightly. **Warning!** Take extreme care during mowing work. When doing such work keep a distance of 30 meters between yourself and other people or animals.

Mowing

When mowing, you want to cut all the vegetation down to the ground. To do this, set the line spool at an angle of 30° to the right. Place the handle in the required position. Remember the increased risk of injury to the user, watchers and animals, and the danger of damaging property due to objects (for example stones) being thrown up (Fig. 9e).

Warning! Do not use the equipment to remove objects from footpaths, etc. The equipment is a powerful tool and can throw small stones and other objects a distance of 15 meters or more, causing injuries and damage to cars, houses and windows.

Sawing

The equipment is not suitable for sawing.

Jamming

If the cutting blade jams as a result of attempting to cut vegetation that is too dense, switch off the engine immediately. Remove the grass and scrub from the equipment before you restart it.

Preventing recoil

When you work with the blade, there is a risk of recoil if it strikes solid objects such as tree trunks, branches, tree stumps, stones or the like. This will throw the equipment backwards in the direction opposite to the rotation of the tool. This can cause you to lose control of the equipment. Do not use the blade near fences, metal posts, boundary

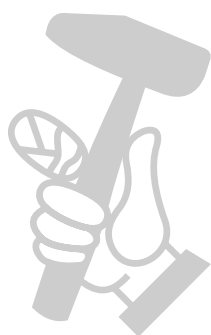

stones or foundations. For cutting dense stalks, position the blade as shown in Fig. 9f to prevent recoil.

9. Maintenance

Always switch off the equipment and pull out the spark boot plug before carrying out any maintenance work.

9.1 Replacing the line spool/cutting line

1. Dismantle the line spool (13) as described in section 5.1.6. Press the spool together (Fig. 12a) and remove one half of the housing (Fig. 12b).
2. Take the line spool out of the line spool housing (Fig. 12c).
3. Remove any remaining cutting line.
4. Place the new cutting line in the center and attach the resulting loop to the recess in the spool splitter (Fig. 12d).
5. Wind the line on to the spool counter-clockwise with tension. The spool splitter will separate the two halves of the nylon line (Fig. 12e).
6. Hook the last 15 cm of the two ends of the line to the line holders opposite the line spool (Fig. 12f).
7. Thread the two ends of the line through the metal eyelets in the line spool housing (Fig. 12c).
8. Press the line spool into the line spool housing.
9. Pull the two line ends sharply to release them from the line holders.
10. Cut the excess line to a length of around 13 cm. This will reduce the load on the engine when starting up and warming up.
11. Fit the line spool again. See section 5.1.6. If you are replacing the complete line spool, ignore points 3-6.

9.2 Grinding the safety hood blade

The safety hood blade can become blunt over time. When you notice this, undo the screw holding the safety hood blade on the safety hood. Clamp the blade in a vise. Sharpen the blade with a flat file and make sure that the angle of the cutting edge is not altered in the process. File in one direction only.

9.3 Maintenance of the air filter (Fig. 10a-10c)

Soiled air filters reduce the engine output by supply too little air to the carburetor. Regular checks are therefore essential. The air filter (10) should be checked after every 25 hours of use and cleaned if necessary. If the air contains a lot of dust, the air filter should be checked more frequently.

1. Remove the air filter cover (Fig. 10a).
2. Remove the filter element (Fig. 10b/10c).
3. Clean the filter element by tapping it or blowing it.
4. Assemble in reverse order.

Important: Never clean the air filter with petrol or inflammable solvents.

9.4 Maintenance of the spark plug (Fig. 11a-11c)

Spark plug sparking gap = 0.6mm. Tighten the spark plug with a torque of 12 to 15 Nm. Check the spark plug for dirt and grime after 10 hours of operation and if necessary clean it with a copper wire brush. Thereafter service the spark plug after every 50 hours of operation.

1. Remove the spark plug connector cover (20) as shown in Fig. 11a.
2. Pull out the spark plug connector (16). (Fig. 11b)
3. Remove the spark plug (Abb. 11c) with the supplied spark plug wrench (27).
4. Assemble in reverse order.

9.5 Carburetor settings

Important. Settings on the carburetor may only be made by authorized customer service personnel. To carry out any work on the carburetor you must first remove the air filter cover as shown in Figures 10a-10c.

Setting the throttle cable:

If the maximum speed of the equipment drops over time and you have ruled out all the other possible causes listed in section 12 „Troubleshooting“, it may be necessary to adjust the throttle cable. First of all check whether the carburetor opens fully when the throttle handle is pressed right through. This is the case if the carburetor slide (Fig. 13a) is completely opened when the throttle is fully activated. Figure 13a shows the correct setting. If the carburetor slide is not completely open, it must be adjusted.

The following steps are required to adjust the throttle cable:

- Undo the lock nut (Fig. 13b/Item C) a few turns.

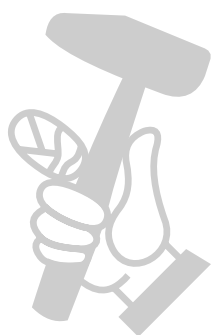

- Undo the adjusting screw (Fig. 13b/Item D) until the carburetor slide is completely open when the throttle is fully activated, as shown in Figure 13a.
- Retighten the lock nut.

9.6 Setting the idling speed

Important! Set the idling speed when the equipment is warm.

Only an authorized service center is allowed to set the idling speed. The start-up speed of the cutting tool must be at least 1.25 times the idling speed.

9.7 Applying grease to the gear unit

After every 20 hours of use add a little gear grease (approx. 10 g) at the lubrication point (C) (Fig. 7c).

10. Cleaning, storage, transport and ordering of spare parts

10.1 Cleaning

- Keep the handles free of oil so that you can maintain a firm grip.
- Clean the equipment as required with a damp cloth and, if necessary, mild washing up liquid.

Important!

Always pull out the spark boot plug each time before carrying out any cleaning. Never immerse the equipment in water or other liquids in order to clean it.

Store the equipment in a safe and dry place out of the reach of children.

10.2 Storage

Important: Never put the equipment into storage for longer than 30 days without carrying out the following steps.

Storing the equipment

If you intend to store the equipment for longer than 30 days, the equipment must be prepared accordingly. Otherwise the fuel still remaining in the carburetor will evaporate and leave a rubbery sediment. This can cause problems when starting up the equipment and may require expensive repairs.

1. Slowly remove the fuel tank cap to release any pressure that may have formed in the tank. Carefully empty the tank.
2. To remove the fuel from the carburetor, start the engine and let it run until it stops.
3. Leave the engine to cool (approx. 5 minutes).

Note: Store the equipment in a dry place and far away from possible ignition sources such as an oven, a gas-fired hot water boiler, a gas-fired dryer, etc.

Putting the equipment back into operation

1. Remove the spark plug (see section 9.4).
2. Clean the spark plug and check that the electrode gap is correct, or insert a new spark plug with the correct electrode gap.
3. Prepare the equipment for operation.
4. Fill the tank with the relevant mixture of fuel and oil. See the section „Fuel and oil“.

10.3 Transport

To transport the machine, empty the petrol tank as described in section 10. Clean coarse dirt off the equipment with a brush or hand brush. Dismantle the drive rod mechanism as described in section 5.1.2.

10.4 Ordering spare parts

Please provide the following information on all orders for spare parts:

- Model/type of the equipment
- Article number of the equipment
- ID number of the equipment
- Part number of the required spare part

For our latest prices and information please go to www.isc-gmbh.info

11. Disposal and recycling

The equipment is supplied in packaging to prevent it from being damaged in transit. The raw materials in this packaging can be reused or recycled. The equipment and its accessories are made of various types of material, such as metal and plastic. Defective components must be disposed of as special waste. Ask your dealer or your local council.

12. Troubleshooting guide

The table below contains a list of fault symptoms and explains what you can do to remedy the problem if your equipment fails to work properly. If the problem still persists after working through the list, please contact your nearest service workshop.

Fault	Possible cause	Remedy
The equipment does not start	<ul style="list-style-type: none"> - Correct starting procedure not followed - Sooted or damp spark plug - Incorrect carburetor setting 	<ul style="list-style-type: none"> - Follow the instructions for starting - Clean the spark plug or replace it with a new one - Contact an authorized customer service outlet or send the equipment to ISC GmbH
The equipment starts but does not develop its full power	<ul style="list-style-type: none"> - Incorrect choke lever setting - Soiled air filter - Incorrect carburetor setting 	<ul style="list-style-type: none"> - Set the choke lever to „\uparrow“ - Clean the air filter - Contact an authorized customer service outlet or send the equipment to ISC GmbH
The engine does not run smoothly	<ul style="list-style-type: none"> - Incorrect electrode gap on the spark plug - Incorrect carburetor setting 	<ul style="list-style-type: none"> - Clean the spark plug and adjust the electrode gap, or fit a new spark plug - Contact an authorized customer service outlet or send the equipment to ISC GmbH
Engine smokes excessively	<ul style="list-style-type: none"> - Incorrect fuel mix - Incorrect carburetor setting 	<ul style="list-style-type: none"> - Use the correct fuel mix (see fuel mixing table) - Contact an authorized customer service outlet or send the equipment to ISC GmbH





For EU countries only

Never place any electric power tools in your household refuse.

To comply with European Directive 2012/19/EC concerning old electric and electronic equipment and its implementation in national laws, old electric power tools have to be separated from other waste and disposed of in an environment-friendly fashion, e.g. by taking to a recycling depot.

Recycling alternative to the return request:

As an alternative to returning the equipment to the manufacturer, the owner of the electrical equipment must make sure that the equipment is properly disposed of if he no longer wants to keep the equipment. The old equipment can be returned to a suitable collection point that will dispose of the equipment in accordance with the national recycling and waste disposal regulations. This does not apply to any accessories or aids without electrical components supplied with the old equipment.

Please note that batteries and lamps (e.g. light bulbs) must be removed from the tool before it is disposed of.

The reprinting or reproduction by any other means, in whole or in part, of documentation and papers accompanying products is permitted only with the express consent of the iSC GmbH.

Subject to technical changes

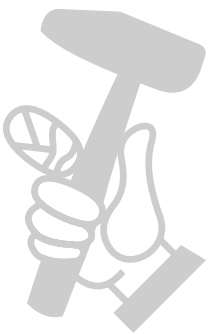

Service information

We have competent service partners in all countries named on the guarantee certificate whose contact details can also be found on the guarantee certificate. These partners will help you with all service requests such as repairs, spare and wearing part orders or the purchase of consumables.

Please note that the following parts of this product are subject to normal or natural wear and that the following parts are therefore also required for use as consumables.

Category	Example
Wear parts*	Spark plug, air filter
Consumables*	Cutting blade, line spool with cutting line
Missing parts	

* Not necessarily included in the scope of delivery!

In the effect of defects or faults, please register the problem on the internet at www.Einhell-Service.com. Please ensure that you provide a precise description of the problem and answer the following questions in all cases:

- Did the equipment work at all or was it defective from the beginning?
- Did you notice anything (symptom or defect) prior to the failure?
- What malfunction does the equipment have in your opinion (main symptom)? Describe this malfunction.



Warranty certificate

Dear Customer,

All of our products undergo strict quality checks to ensure that they reach you in perfect condition. In the unlikely event that this equipment develops a fault, please contact our service department at the address shown on this guarantee card. You can also contact us by telephone using the service number shown. Please note the following terms under which guarantee claims can be made:

1. These guarantee terms apply solely to consumers, i.e. natural persons, who do not want to use this product in connection with either their commercial or other self-employed activities. These guarantee terms regulate additional guarantee services which the undermentioned manufacturer promises to buyers of its new products in addition to their statutory rights of guarantee. Your statutory rights of guarantee are not affected by this guarantee. Our guarantee is free of charge to you.
2. The guarantee services cover only defects due to material or manufacturing faults on the new product which you have bought in the European Union from the undermentioned manufacturer and are limited to either the rectification of said defects or the replacement of the product, whichever we prefer. Please note that only equipment under the brand name "Professional" has been designed for use in commercial, trade or professional applications. For all other products the guarantee is invalidated if the equipment is used within the guarantee period in commercial, trade or industrial applications or for other equivalent activities.
3. Our guarantee does not cover:
 - Damage to the equipment caused by failure to comply with the installation/assembly instructions or by unprofessional installation; damage caused by failure to comply with the operating instructions (e.g. connection to the wrong mains voltage or current type); damage caused by failure to comply with the maintenance and safety regulations; damage caused by exposing the equipment to abnormal environmental conditions; damage resulting from poor care and maintenance.
 - Damage to the equipment caused by misuse or incorrect applications (e.g. overloading the equipment or using non-approved attachments or accessories); damage caused by foreign bodies (e.g. sand, stones, dust, ...) getting inside the equipment. Damage in transit; damage caused by force or external influences (e.g. by dropping the equipment).
 - Damage to the equipment or parts of the equipment which is owed to use-related, normal or otherwise natural wear. For example, batteries and battery packs are manufactured with a cycle limit for design-related reasons. Wear is negatively influenced in particular by load demands and charging speeds as well as exposure to heat, cold, vibration and impact.
4. The guarantee is valid for a period of 2 years starting from the purchase date of the equipment. Guarantee claims must be submitted before the end of the guarantee period and within two weeks of the defect being noticed. No guarantee claims will be accepted after the end of the guarantee period. The original guarantee period remains applicable to the equipment even if repairs are carried out or parts are replaced. In such cases, the work performed or parts fitted will not result in an extension of the guarantee period, and no new guarantee will become active for the work performed or for any replacement parts fitted. This also applies if on-site service is used.
5. To assert your guarantee claim, register the defective equipment at: www.Einhell-Service.com. You will need to provide proof of purchase of the new item of equipment. Equipment returned without such proof or without a rating plate are excluded from the guarantee services because of the lack of traceability. If the defect is covered by our guarantee, then either the item in question will be repaired immediately and returned to you or we will send you a new replacement.
6. If you have taken the equipment with you to a different EU country than where you bought it, we will arrange for a local service partner to provide the guarantee services. If you take the equipment outside the EU, the guarantee will not apply.

Of course, we are also happy to offer a chargeable repair service for any defects which are not covered or no longer covered by the scope of this guarantee. To take advantage of this service, please send the equipment to our service address. We draw attention to the restrictions of this guarantee concerning wear parts, consumables and missing parts as presented in the service information included in this operating manual.

Warrantor/ Service:

Einhell UK Ltd, Unit 10, 1st Floor, Champion's Business Park, Arrowe Brook Road, Upton, Wirral, CH49 0UQ