

D	Originalbetriebsanleitung Akku-Rasenmäher	SLO	Originalna navodila za uporabo Akumulatorska kosilnica za travo
GB	Original operating instructions Cordless lawn mower	H	Eredeti használati utasítás Akku-fűnyírógép
F	Instructions d'origine Tondeuse a gazon a accumulateur	RO	Instrucțiuni de utilizare originale Mașină de tuns gazonul cu acumulator
I	Istruzioni per l'uso originali Tosaerba a batteria	GR	Πρωτότυπες Οδηγίες χρήσης Χλοκοπτικό με μπαταρία
DK/ N	Original betjeningsvejledning Akku-græsslåmaskine	P	Manual de instrucções original Corta-relvas sem fio
S	Original-bruksanvisning Batteridrivnen gräsklippare	HR/ BIH	Originalne upute za uporabu Akumulatorska kosilica za travu
CZ	Originální návod k obsluze Akumulátorová sekačka	RS	Originalna uputstva za upotrebu Akumulatorska kosilica za travu
SK	Originálny návod na obsluhu Akumulátorová kosačka	PL	Instrukcja oryginalną Akumulatorowa kosiarka do trawy
NL	Originele handleiding Accugazonmaaier	TR	Orijinal Kullanma Talimatı Akülü çim biçme makinesi
E	Manual de instrucciones original Cortacésped a batería	EE	Originaalkasutusjuhend Akuga muruniiduk
FIN	Alkuperäiskäyttöohje Akkukäyttöinen ruohonleikkuri		

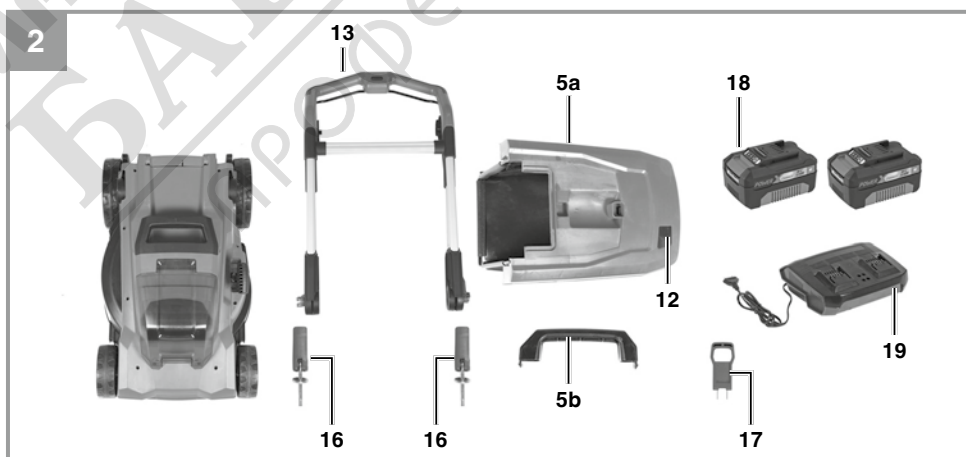

Art.-Nr.: 34.132.78 (2x4,0 Ah)

I.-Nr.: 21012

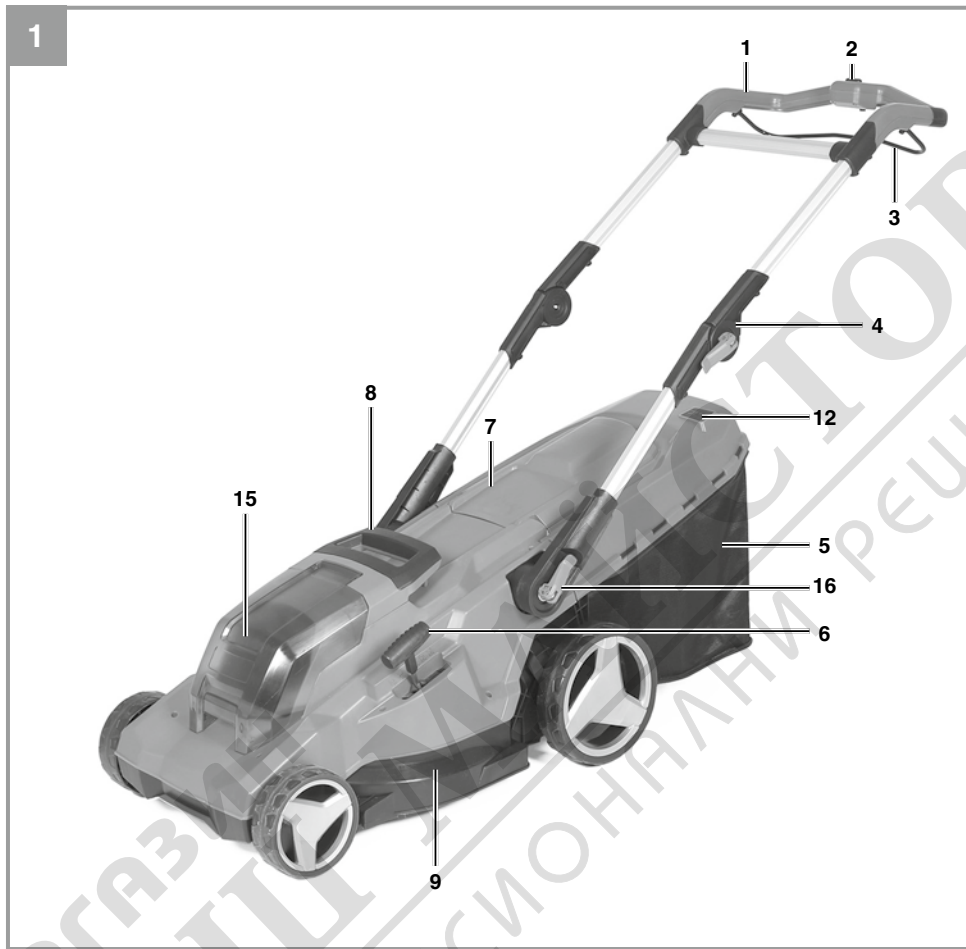

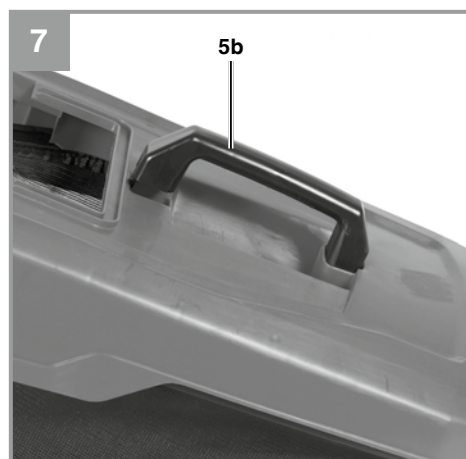
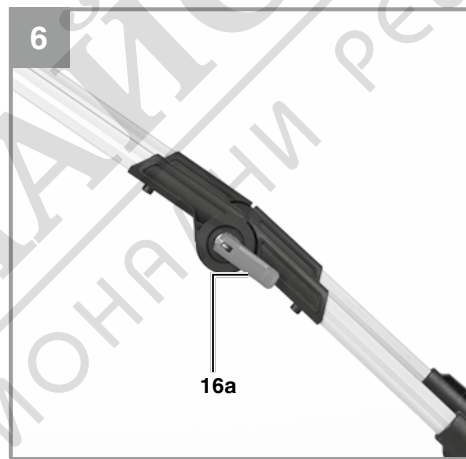
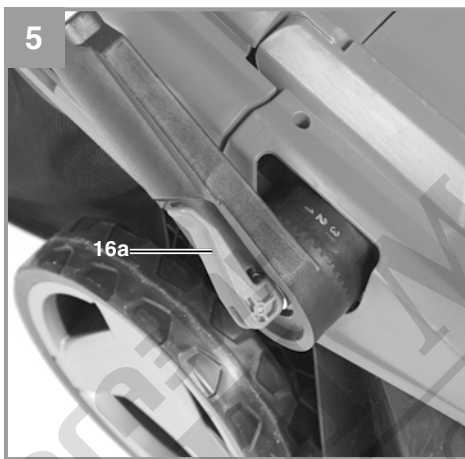
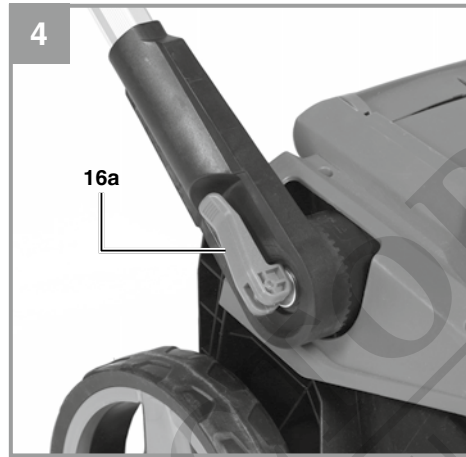
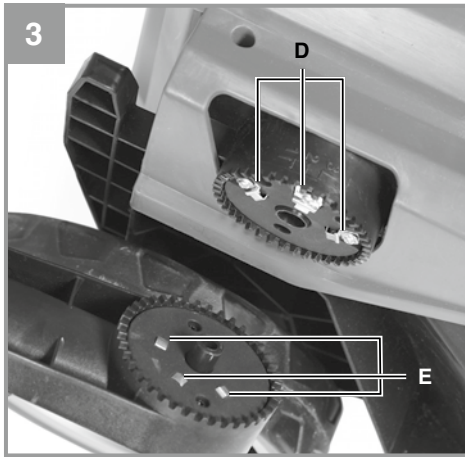

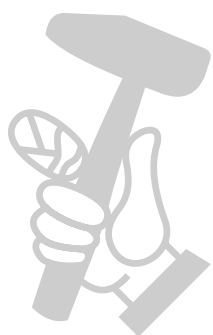
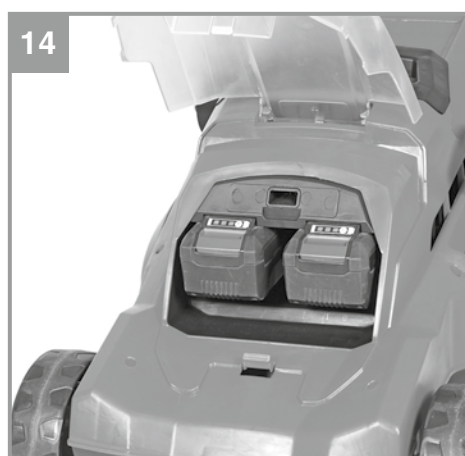
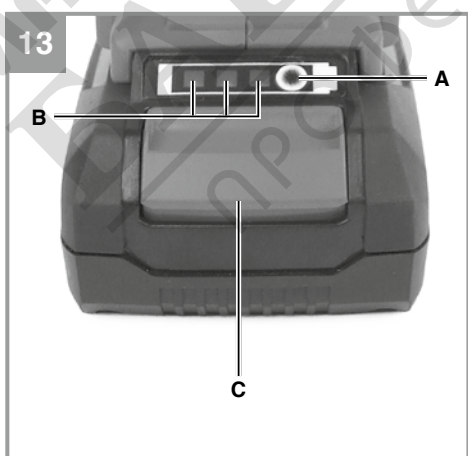
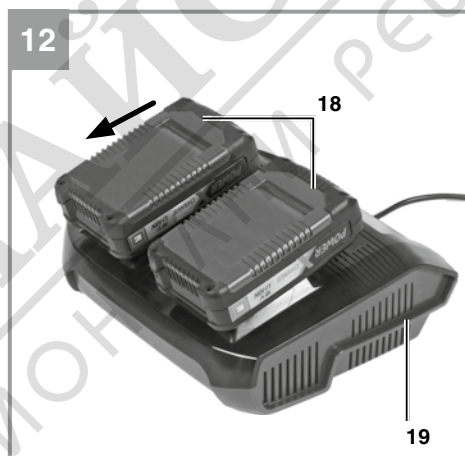
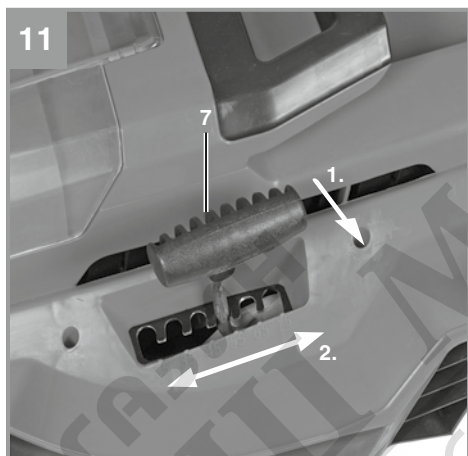
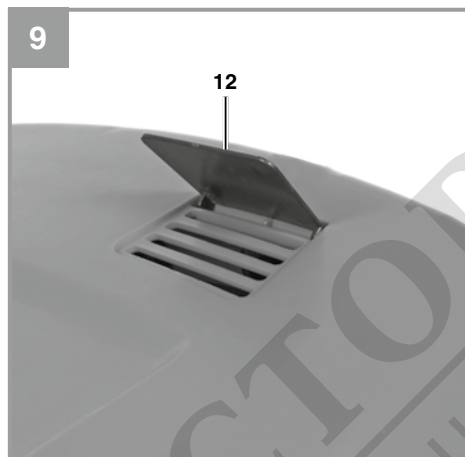
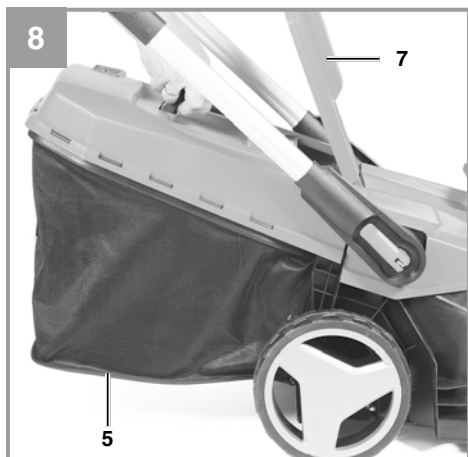

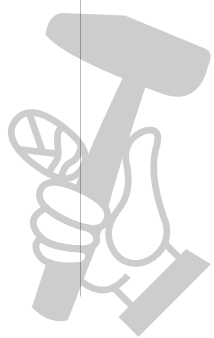
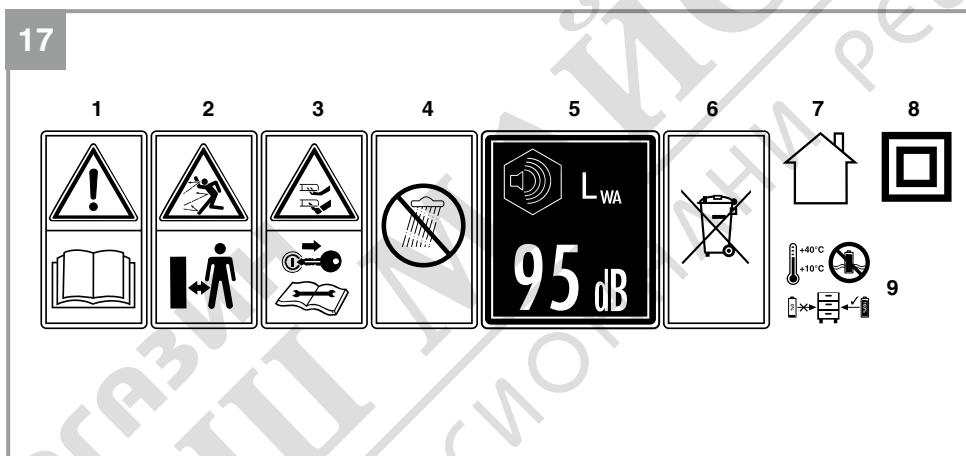
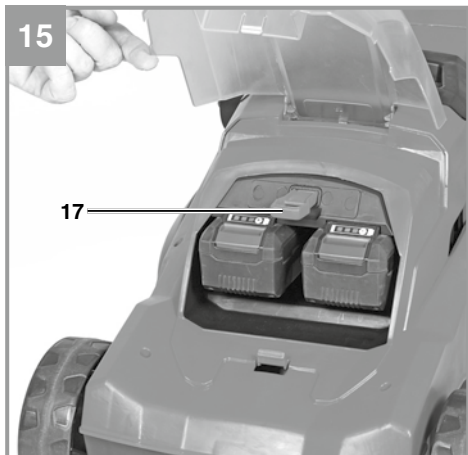

Danger!

When using the equipment, a few safety precautions must be observed to avoid injuries and damage. Please read the complete operating instructions and safety regulations with due care. Keep this manual in a safe place, so that the information is available at all times. If you give the equipment to any other person, hand over these operating instructions and safety regulations as well. We cannot accept any liability for damage or accidents which arise due to a failure to follow these instructions and the safety instructions.

Explanation of the symbols used (see Fig. 17)

1. Read the directions for use before operating the equipment.
2. Keep your distance!
3. Caution: Sharp blades! Pull out the safety plug before carrying out any repair work or if the power cable is damaged. The blades will continue to rotate after the motor is switched off.
4. Protect the equipment from rain and damp conditions
5. Guaranteed sound power level
6. Dispose of batteries correctly
7. For use in dry rooms only
8. Safety class II
9. Store the battery only in dry rooms with an ambient temperature of +10°C to +40°C. Place only charged batteries in storage (charged at least 40%).

1. Safety regulations

The corresponding safety information can be found in the enclosed booklet.

Warning!

Read all the safety information, instructions, illustrations and technical data provided on or with this power tool. Failure to adhere to the following instructions may result in electric shock, fire and/or serious injury.

Keep all the safety information and instructions in a safe place for future use.

Children are not allowed to use this equipment. Children are not allowed to carry out cleaning or maintenance. This equipment can be used by people with limited physical, sensory or mental capacities or those with no experience and knowledge if they are supervised or have received instruction in how to use the equipment safely

and understand the dangers which result from such use. Children are not allowed to play with the equipment.

2. Layout and items supplied**2.1 Layout (Fig. 1/2)**

1. Upper push bar
2. Safety lock-off
3. Switching bar
4. Joint
5. Catch basket
- 5a. Grass catch basket, without carry-handle
- 5b. Grass catch basket, carry-handle
6. Central cutting height adjustment facility
7. Ejector flap
8. Carry-handle
9. Cutting tool cover
12. Fill level indicator
13. Complete push bar
15. Battery cover
16. Quick-tightening screws
17. Safety plug
18. Rechargeable battery
19. Battery charger

2.2 Items supplied and unpacking (Fig. 2)

Please check that the article is complete as specified in the scope of delivery. If parts are missing, please contact our service center or the sales outlet where you made your purchase at the latest within 5 working days after purchasing the product and upon presentation of a valid bill of purchase. Also, refer to the warranty table in the service information at the end of the operating instructions.

- Open the packaging and take out the equipment with care.
- Remove the packaging material and any packaging and/or transportation braces (if available).
- Check to see if all items are supplied.
- Inspect the equipment and accessories for transport damage.
- If possible, please keep the packaging until the end of the guarantee period.

Danger!

The equipment and packaging material are not toys. Do not let children play with plastic bags, foils or small parts. There is a danger of swallowing or suffocating!

Items supplied

- Cordless lawn mower
- Rechargeable batteries (2x)
- Battery charger
- Original operating instructions
- Safety information

3. Proper use

The lawn mower is intended for private use i.e. for use in home and gardening environments.

Private use of the lawn mower refers an annual operating time generally not exceeding that of 50 hours, during which time the equipment is primarily used to maintain small-scale, residential lawns and home/hobby gardens. Public facilities, sporting halls, and agricultural/forestry applications are excluded.

Important. Due to the high risk of bodily injury to the user, the lawn mower may not be used to trim bushes, hedges or shrubs, to cut scaling vegetation, planted roofs, or balcony-grown grass, to clean (suck up) dirt and debris off walkways, or to chop up tree or hedge clippings. Moreover, the lawn mower may not be used as a power cultivator to level out high areas such as molehills.

For safety reasons, the lawn mower may not be used as a drive unit for other work tools or toolkits of any kind, unless they have been expressly permitted by the manufacturer.

The equipment is to be used only for its prescribed purpose. Any other use is deemed to be a case of misuse. The user / operator and not the manufacturer will be liable for any damage or injuries of any kind caused as a result of this.

Please note that our equipment has not been designed for use in commercial, trade or industrial applications. Our warranty will be voided if the machine is used in commercial, trade or industrial businesses or for equivalent purposes.

4. Technical data

Voltage36 V d.c.
 Motor speed:.....3400 min⁻¹
 Protection type:.....IPX1
 Protection class:.....III

Weight:.....16.4 kg
 Cutting width:.....40 cm
 Grass basket volume:50 liters
 Sound pressure level L_{PA}:.....82.2 dB(A)
 Uncertainty K_{PA}:.....3 dB(A)
 Sound power level L_{WA}:.....92.8 dB(A)
 Uncertainty K_{WA}:.....1.79 dB(A)
 Guaranteed sound power level L_{WA}:.....95 dB(A)
 Vibration at the handlebars a_h:.....3.432 m/s²
 Uncertainty K:.....1.5 m/s²
 Cutting height adjustment:25-75 mm; 6 levels

2x Power X-Change lithium-ion batteries

Voltage:18 V DC
 Capacity:4.0 Ah
 Number of cells:10

Power-X Twincharger battery charger

Input voltage:200-240 V ~ 50-60 Hz
 Output voltage:2x 18 V DC
 Output current:2x 3.0 A
 Protection class:.....II /

Sound and vibration values were measured in accordance with the standards EN ISO 3744:1995, EN ISO 11201: 1996 and EN ISO 20643:2008.

Keep the noise emissions and vibrations to a minimum.

- Only use appliances which are in perfect working order.
- Service and clean the appliance regularly.
- Adapt your working style to suit the appliance.
- Do not overload the appliance.
- Have the appliance serviced whenever necessary.
- Switch the appliance off when it is not in use.
- Wear protective gloves.

Residual risks

Even if you use this electric power tool in accordance with the instructions, certain residual risks cannot be eliminated. The following hazards may arise in connection with the equipment's construction and layout:

1. Lung damage if no suitable protective dust mask is used.
2. Damage to hearing if no suitable ear protection is applied.

5. Before starting the equipment

The lawn mower is delivered partly assembled. The push bar and the grass basket must be assembled before using the lawn mower. Follow the instructions step by step and refer to the pictures when assembling.

Important! Required assembly parts (screws, cable guides, etc.) or functional parts (e.g. plugs, wrenches, etc.) can be found in the molded parts of the packaging or on the equipment.

There are three contacts on the right-hand teeth of the handlebar adjustment facility (Fig. 3/Item D), as well as on the right-hand push bar (Fig. 3/Item E). The contacts are for connecting the electrical connections of the motor and switching bar.

To avoid a loose connection while mowing, which would cause the motor to stop, the contacts on the handlebar adjustment facility and the push bar must be pressed firmly together. If necessary, turn the quick-release lever on the right-hand side in a clockwise direction a little after flipping it back into the closed position.

Fitting the push bar

Use the quick-tightening screws (Fig. 2/Item 16) to fasten the push bar (Fig. 2/Item 13) to the teeth of the handlebar adjustment facility. If necessary, turn the quick-tightening screw back sufficiently on the thread so that the quick-release lever (Fig. 4/Item 16a) can then still be flipped down towards the back.

You can adjust the angle of the long handle as a whole by flipping up the two quick-release levers (Fig. 5/Item 16a), with three settings available for the angle (Fig. 5). Only these three positions are available. As you do this, make sure that both sides are set to the same position. To secure the push bar again, flip the two quick-release levers back into the closed position.

You can adjust the angle of the upper push bar (Fig. 6a) by flipping up the two upper quick-release levers (Fig. 6/Item 16a), with three settings available for the angle. As you do this, make sure that both sides are set to the same position. To secure the push bar again, flip the two quick-release levers back into the closed position.

Fitting the catch basket

Finally, press the carry-handle (Fig. 7/Item 5b) onto the top part of the housing of the catch basket. During assembly, make sure that there is an audible click when you fit the individual parts of the housing together. Before you fit the catch basket you must ensure that the motor is switched off and the blade is not rotating. Lift the ejector flap (Fig. 8/Item 7) with one hand. Using the other hand, grab onto the basket by the handle and hang it in from the top.

Filling level indicator of the grass collector

The grass collector is equipped with a filling level indicator (Fig. 9/Item 12), which is opened by the airflow that the lawn mower generates during operation. If the flap closes during mowing, the grass collecting device is full and must be emptied. To ensure the proper functioning of the filling level indicator, the holes under the flap must always be kept clean and passable.

Adjusting the cutting height

Caution!

Adjust the cutting height only when the machine has been switched off and the safety plug has been pulled out.

The cutting height is adjusted as follows (see Fig. 11):

1. Push the lever (7) outwards.
2. Set the lever (7) to the desired cutting height.
3. Release the lever (7) and check that it is securely seated in the lock.

Reading off the cutting height

The cutting height can be set between 25-75 mm in 6 intervals, and can be read off on the scale.

Before you begin to mow, check to ensure that the blade is not blunt and that none of the fasteners are damaged. To prevent any imbalance, replace blunt and/or damaged blades. To carry out this check, first switch off the motor and pull out the safety plug.

Charging the battery (Fig. 12)

1. Take the battery pack out of the equipment. To do so, press the pushlock button (Fig. 13/Item C).
2. Check that your mains voltage is the same as that marked on the rating plate of the battery charger. Insert the power plug of the charger into the socket outlet. The green LED will then begin to flash.

3. Slot the battery pack or packs onto the battery charger.
4. In the section entitled „Charger indicator“ you will find a table with an explanation of the LED indicator on the charger.

The battery pack can become a little warm during the charging. This is normal.

If the battery pack fails to charge, check:

- whether there is voltage at the socket outlet
- whether there is good contact at the charging contacts

If the battery pack still fails to charge, send

- the charging unit
 - and the battery pack
- to our customer service center.

To ensure that items are properly packaged and delivered when you send them to us, please contact our customer service or the point of sale at which the equipment was purchased.

When shipping or disposing of batteries and cordless tools, always ensure that they are packed individually in plastic bags to prevent short circuits and fires.

To ensure that the battery pack provides long service, you should take care to recharge it promptly. You must recharge the battery pack when you notice that the performance of the device drops. Never allow the battery pack to become fully discharged. This will cause it to develop a defect.

Battery capacity indicator (Fig. 13)

Press the button for the battery capacity indicator (Item A). The battery capacity indicator (Item B) shows the charge status of the battery using 3 LEDs.

All 3 LEDs are lit:

The battery is fully charged.

2 or 1 LED(s) are lit:

The battery has an adequate remaining charge.

1 LED flashes:

The battery is empty, recharge the battery.

All LEDs blink:

The battery temperature is too low. Remove the battery from the equipment, keep it at room tem-

perature for one day. If the fault reoccurs, this means that the rechargeable battery has undergone exhaustive discharge and is defective. Remove the battery from the equipment. Never use or charge a defective battery.

Installing the battery (Fig. 14)

Open the battery cover. Then insert the batteries in the mounts as shown in Fig. 14.

Important!

Use only batteries which are charged to the same level. Never combine full and half-full batteries. Always charge the two batteries simultaneously. The equipment's operating time depends on the battery with the lower charge level. The two batteries must always be fully charged before use. Close the battery cover by flipping the cover down.

6. Operation

Caution!

The lawn mower is equipped with a safety circuit to prevent unauthorized use. Directly before starting up the lawn mower insert the safety plug (Fig. 15/Item 17) and remove the safety plug again whenever you interrupt or terminate your work.

Important!

To prevent the equipment switching on accidentally, the lawn mower is equipped with a safety switch (Fig. 1/Item 2) which must be pressed before the switching bar (Fig. 1/Item 3) can be activated. The lawn mower switches itself off when the switching bar is released. The start time can amount to several seconds. Repeat this process several times so that you are sure that the machine functions properly. Before you perform any repair or maintenance work on the equipment, ensure that the blade is not rotating and that the safety plug is disconnected.

Caution! Never open the chute flap when the grass bag has been detached (to be emptied) and the motor is still running. A rotating blade can cause serious injuries!

Always carefully fasten the chute flap and grass basket. Switch off the engine before emptying the grass basket.

Always ensure that a safe distance (provided by the length of the long handles) is maintained

between the user and the mower housing. Be especially careful when mowing and changing direction on slopes and inclines. Maintain a solid footing and wear sturdy, non-slip footwear and long trousers.

Always mow along the incline (not up and down). For safety reasons, the lawn mower may not be used to mow inclines whose gradient exceeds 15 degrees.

Use special caution when backing up and pulling the lawn mower. Tripping hazard!

Tips for proper mowing

It is recommended that you overlap the mowing swaths.

Only use a sharp blade that is in good condition. This will prevent the grass blades from fraying and the lawn from turning yellow.

Try to mow in straight lines for a nice, clean look. The swaths should overlap each other by a few centimeters in order to avoid stripes.

The operating time of the rechargeable batteries and therefore the area in square meters that can be covered with a single battery charge is largely dependent on the state of the grass (e.g. density, moisture, height, cutting height, etc.) and the mowing speed (walking speed). To adjust the area coverage to your individual requirements, it is recommended that you mow the lawn more often, with a higher cutting height and at an appropriate speed. Frequently turning the equipment on and off while mowing will also reduce the amount of area that you can cover. If the operating time of the rechargeable batteries (area coverage) is still unsatisfactory in spite of the above measures, you can remedy the problem by using rechargeable batteries with a larger capacity (Ah).

How frequently you should mow your lawn is determined primarily by the speed at which the grass grows. In the main growing season (May - June) you will probably need to mow the lawn twice a week, otherwise just once a week. The cutting height should be between 4 - 6cm and the amount of growth before mowing again should be 4 - 5cm. If the grass is allowed to grow somewhat longer for whatever reason, do not make the mistake of cutting it back to the normal height in one go. This will harm the lawn. Never cut it back by more than half the height in one go.

Keep the underside of the mower housing clean and remove grass build-up. Deposits not only

make it more difficult to start the mower; they decrease the quality of the cut and make it harder for the equipment to bag the grass.

Always mow along inclines (not up and down). You can prevent the lawn mower from slipping down by holding a position at an angle upwards.

Select the cutting height according to the length of the grass. Make several passes so that no more than 4cm of grass are cut at one time. Switch off the motor before doing any checks on the blade. Keep in mind that the blade continues to rotate for a few seconds after the motor has been switched off. Never attempt to manually stop the blade. Regularly check to see if the blade is securely attached, is in good condition and is sharp. If the contrary is the case, sharpen the blade or replace it. In the event that the blade strikes an object, immediately switch off the lawn mower and wait for the blade to come to a complete stop. Then inspect the condition of the blade and the blade mount. Replace any parts that are damaged.

As soon as grass clippings start to trail the lawn mower, it is time to empty the grass basket.

Important! Before taking off the grass basket, switch off the motor and wait until the blade has come to a stop.

To take off the grass basket, use one hand to lift up the chute flap and the other to grab onto the basket handle. Remove the basket. For safety reasons, the chute flap automatically falls down after removing the grass basket and closes off the rear chute opening. If any grass remains in the opening, it will be easier to restart the engine if you pull the mower back approximately 1m.

Do not use your hands or feet to remove clippings in or on the mower housing, but instead use suitable tools such as a brush or a hand broom.

In order to ensure that the majority of grass clippings are picked up, the inside of the grass basket must be cleaned after each use.

Reattach the grass basket only when the motor is switched off and the blade has stopped.

Lift up the chute flap with one hand and, holding the grass basket by its handle with the other hand, hang in the basket from the top.

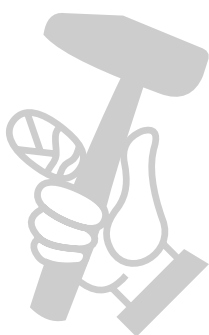

7. Cleaning, maintenance and ordering of spare parts

Danger!

Pull out the safety plug before carrying out any cleaning work (Fig. 15). Remove the rechargeable batteries.

7.1 Cleaning

- Keep all safety devices, air vents and the motor housing free of dirt and dust as far as possible. Wipe the equipment with a clean cloth or blow it with compressed air at low pressure.
- Do not clean the lawn mower with running water, particularly with high-pressure water.
- We recommend that you clean the device immediately each time you have finished using it.
- Clean the equipment regularly with a moist cloth and some soft soap. Do not use cleaning agents or solvents; these could attack the plastic parts of the equipment. Ensure that no water can seep into the device.
- For best results, clean the lawn mower with a brush or rag.

7.2 Maintenance

- Worn out or damaged blades, blade mounts, and bolts should be replaced as a set by an authorized professional in order to keep the equipment in balance.
- Ensure that all mounting components (i.e. screws, bolts, nuts etc.) are always tightened so that the equipment can be safely operated at all times.
- Frequently check the grass catch assembly for signs of wear.
- Replace excessively worn or damaged parts immediately.
- In order to ensure that you enjoy the equipment for many years to come, all screwed parts, as well as the wheels and axles, should be cleaned and lubricated.
- Keeping your lawn mower in good condition not only ensures a long lifespan and high performance, but also enables the equipment to thoroughly cut your grass with minimal effort.
- The blade is subjected to more wear and tear than any other component. Therefore, routinely check the condition of the blade and make sure that it is tightly fastened. If the blade is completely worn out, it must be immediately replaced or ground sharp again. An

excessively vibrating mower means that the blade is not properly balanced or has become deformed from striking an object. In this case, the blade must be repaired or replaced.

- There are no parts inside the equipment which require additional maintenance.

7.3 Replacing the blade

For safety reasons, we recommend having the blade replaced by an authorized professional.

Important! Wear work gloves! Only replace the blade with a genuine Einhell replacement blade, as this will ensure top performance and safety under all conditions.

Carry out the following steps to change the blade:

1. Undo the fastening screw SW13 (see Fig. 16/1).
2. Remove the blade and replace with a new one.
3. When fitting the blade, make sure it is installed in the right direction. The blade's air vanes must project into the motor compartment (see Fig. 16). The dome mounts must be aligned with the punch holes in the blade.
4. Then retighten the fastening screw with the universal wrench (see Fig. 16/2). The tightening torque should be approx. 25 Nm.

At the end of the season, perform a general inspection of the lawn mower and remove any grass and dirt which may have accumulated. At the start of each season, ensure that you check the condition of the blade. If repairs are necessary, please contact our customer service center. Use only genuine spare parts.

7.4 Ordering replacement parts:

Please quote the following data when ordering replacement parts:

- Type of machine
- Article number of the machine
- Identification number of the machine
- Replacement part number of the part required

For our latest prices and information please go to www.Einhell-Service.com

Spare blade art. no.: 34.054.54

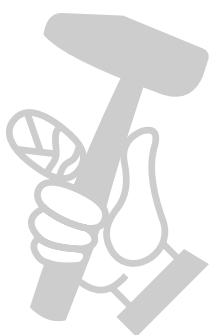

8. Storage and transport

Remove the rechargeable batteries.

Storage

Store the equipment and accessories out of children's reach in a dark and dry place at above freezing temperature. The ideal storage temperature is between 5 and 30 °C. Store the machine in its original packaging.

Transport

- Switch the machine off and isolate it from the power supply before transporting it.
- Fit the shipping protectors, if any.
- Protect the machine from damage and the strong vibrations that can occur particularly when transporting in vehicles.
- Secure the machine against slipping and tipping over.

9. Disposal and recycling

The equipment is supplied in packaging to prevent it from being damaged in transit. The raw materials in this packaging can be reused or recycled. The equipment and its accessories are made of various types of material, such as metal and plastic. Never place defective equipment in your household refuse. The equipment should be taken to a suitable collection center for proper disposal. If you do not know the whereabouts of such a collection point, you should ask in your local council offices.

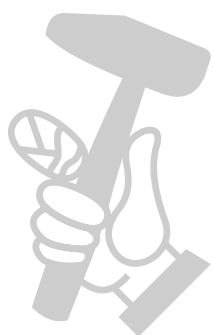

10. Charger indicator

Indicator status		Explanations and actions
Red LED	Green LED	
Off	Flashing	<p>Ready for use The charger is connected to the mains and is ready for use; there is no battery pack in the charger</p>
On	Off	<p>Charging The charger is charging the battery pack in quick charge mode. The charging times are shown directly on the charger. Important! The actual charging times may vary slightly from the stated charging times depending on the existing battery charge.</p>
Off	On	<p>The battery is charged and ready for use. (READY TO GO) The unit then changes over to gentle charging mode until the battery is fully charged. To do this, leave the rechargeable battery on the charger for approx. 15 minutes longer. Action: Take the battery pack out of the charger. Disconnect the charger from the mains supply.</p>
Flashing	Off	<p>Adapted charging The charger is in gentle charging mode. For safety reasons the charging is performed less quickly and takes more time. The reasons can be: - The rechargeable battery has not been used for a very long time. - The battery temperature is outside the ideal range. Action: Wait for the charging to be completed; you can still continue to charge the battery pack.</p>
Flashing	Flashing	<p>Fault Charging is no longer possible. The battery pack is defective. Action: Never charge a defective battery pack. Take the battery pack out of the charger.</p>
On	On	<p>Temperature fault The battery pack is too hot (e.g. due to direct sunshine) or too cold (below 0° C). Action: Remove the battery pack and keep it at room temperature (approx. 20° C) for one day .</p>

11. Troubleshooting

Fault	Possible causes	Remedies
Motor does not start or comes to a stop (loose connection)	<ul style="list-style-type: none"> a) Motor terminals disconnected b) The mower is standing in high grass c) The mower housing is clogged d) Safety switch is not inserted e) Battery is not correctly inserted f) Insufficient or no contact between the handle and the handle fastener (Fig. 3 / Section 5). 	<ul style="list-style-type: none"> a) Have repaired by the Customer Service Center b) Start in low grass or on an area that has already been mowed; change the cutting height if necessary c) Clean the housing so that the blade moves freely d) Insert safety switch (see 6.) e) Remove the battery and reinsert (see 5.) f) Undo the handle connection, check the contacts for dirt and carefully clean with a brush. Tighten the handle connection (see 5).
The motor performance drops	<ul style="list-style-type: none"> a) The grass is too high or too damp b) The mower housing is clogged c) The blade is severely worn d) Battery performance decreasing 	<ul style="list-style-type: none"> a) Correct the cutting height b) Clean the housing c) Replace the blade d) Check the battery performance and charge the battery if necessary (see 5.)
Cutting is irregular	<ul style="list-style-type: none"> a) The blade is worn b) Wrong cutting height 	<ul style="list-style-type: none"> a) Replace or sharpen the blade b) Correct the cutting height

Notice! For protection, the motor is equipped with a thermal switch which cuts out when the motor is overloaded and switches on again automatically after a short cooling period





For EU countries only

Never place any electric power tools in your household refuse.

To comply with European Directive 2012/19/EC concerning old electric and electronic equipment and its implementation in national laws, old electric power tools have to be separated from other waste and disposed of in an environment-friendly fashion, e.g. by taking to a recycling depot.

Recycling alternative to the return request:

As an alternative to returning the equipment to the manufacturer, the owner of the electrical equipment must make sure that the equipment is properly disposed of if he no longer wants to keep the equipment. The old equipment can be returned to a suitable collection point that will dispose of the equipment in accordance with the national recycling and waste disposal regulations. This does not apply to any accessories or aids without electrical components supplied with the old equipment.

Please note that batteries and lamps (e.g. light bulbs) must be removed from the tool before it is disposed of.

The reprinting or reproduction by any other means, in whole or in part, of documentation and papers accompanying products is permitted only with the express consent of the Einhell Germany AG.

Subject to technical changes

This consignment contains lithium-ion batteries.

In accordance with special provision 188 this consignment is not subject to the ADR regulations. Handle with care. Danger of ignition in case of damage to the consignment package. If the consignment package is damaged: Check and if necessary repackage.

For further information contact: 0049 9951 95920-66. Outside Germany charges will apply instead for a regular call to a landline number in Germany.

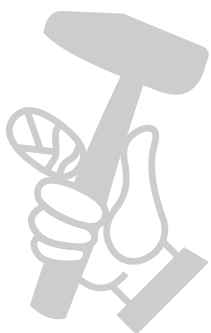

Service information

We have competent service partners in all countries named on the guarantee certificate whose contact details can also be found on the guarantee certificate. These partners will help you with all service requests such as repairs, spare and wearing part orders or the purchase of consumables.

Please note that the following parts of this product are subject to normal or natural wear and that the following parts are therefore also required for use as consumables.

Category	Example
Wear parts*	Carbon brushes, Battery
Consumables*	Blade
Missing parts	

* Not necessarily included in the scope of delivery!

In the effect of defects or faults, please register the problem on the internet at www.Einhell-Service.com. Please ensure that you provide a precise description of the problem and answer the following questions in all cases:

- Did the equipment work at all or was it defective from the beginning?
- Did you notice anything (symptom or defect) prior to the failure?
- What malfunction does the equipment have in your opinion (main symptom)? Describe this malfunction.



Warranty certificate

Dear Customer,

All of our products undergo strict quality checks to ensure that they reach you in perfect condition. In the unlikely event that your device develops a fault, please contact our service department at the address shown on this guarantee card. You can also contact us by telephone using the service number shown. Please note the following terms under which guarantee claims can be made:

1. These guarantee terms apply to consumers only, i.e. natural persons intending to use this product neither for their commercial activities nor for any other self-employed activities. These warranty terms regulate additional warranty services, which the manufacturer mentioned below promises to buyers of its new products in addition to their statutory rights of guarantee. Your statutory guarantee claims are not affected by this guarantee. Our guarantee is free of charge to you.
2. The warranty services cover only defects due to material or manufacturing faults on a product which you have bought from the manufacturer mentioned below and are limited to either the rectification of said defects on the product or the replacement of the product, whichever we prefer. Please note that our devices are not designed for use in commercial, trade or professional applications. A guarantee contract will not be created if the device has been used by commercial, trade or industrial business or has been exposed to similar stresses during the guarantee period.
3. The following are not covered by our guarantee:
 - Damage to the device caused by a failure to follow the assembly instructions or due to incorrect installation, a failure to follow the operating instructions (for example connecting it to an incorrect mains voltage or current type) or a failure to follow the maintenance and safety instructions or by exposing the device to abnormal environmental conditions or by lack of care and maintenance.
 - Damage to the device caused by abuse or incorrect use (for example overloading the device or the use of unapproved tools or accessories), ingress of foreign bodies into the device (such as sand, stones or dust, transport damage), the use of force or damage caused by external forces (for example by dropping it).
 - Damage to the device or parts of the device caused by normal or natural wear or tear or by normal use of the device.
4. The guarantee is valid for a period of 24 months starting from the purchase date of the device. Guarantee claims should be submitted before the end of the guarantee period within two weeks of the defect being noticed. No guarantee claims will be accepted after the end of the guarantee period. The original guarantee period remains applicable to the device even if repairs are carried out or parts are replaced. In such cases, the work performed or parts fitted will not result in an extension of the guarantee period, and no new guarantee will become active for the work performed or parts fitted. This also applies if an on-site service is used.
5. To make a claim under the guarantee, please register the defective device at: www.Einhell-Service.com. Please keep your bill of purchase or other proof of purchase for the new device. Devices that are returned without proof of purchase or without a rating plate shall not be covered by the guarantee, because appropriate identification will not be possible. If the defect is covered by our guarantee, then the item in question will either be repaired immediately and returned to you or we will send you a new replacement.

Of course, we are also happy offer a chargeable repair service for any defects which are not covered by the scope of this guarantee or for units which are no longer covered. To take advantage of this service, please send the device to our service address.

Also refer to the restrictions of this warranty concerning wear parts, consumables and missing parts as set out in the service information in these operating instructions.