

BLACK+ DECKER

TM

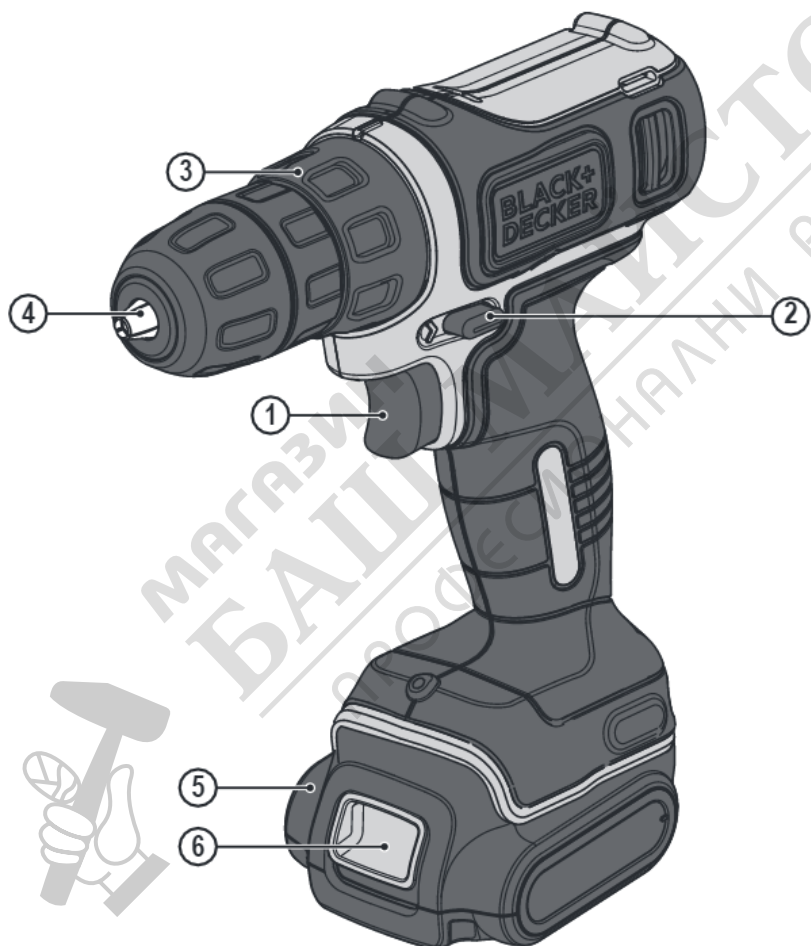

www.blackanddecker.co.uk

KFBCD600

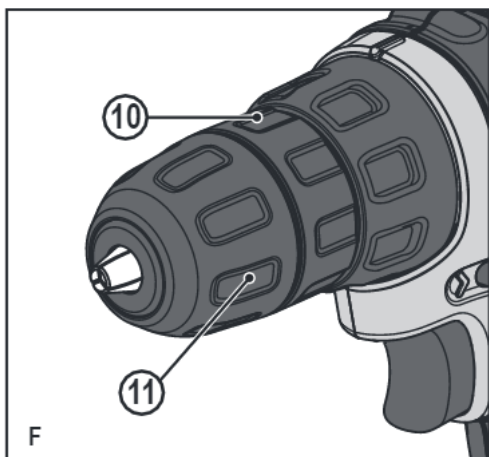
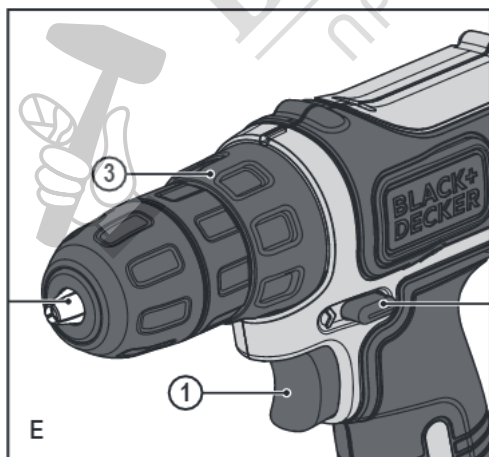
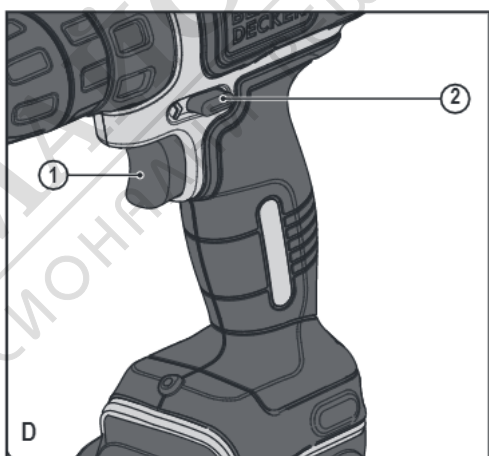
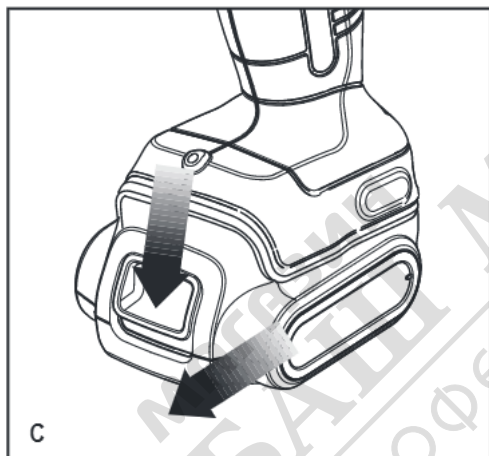
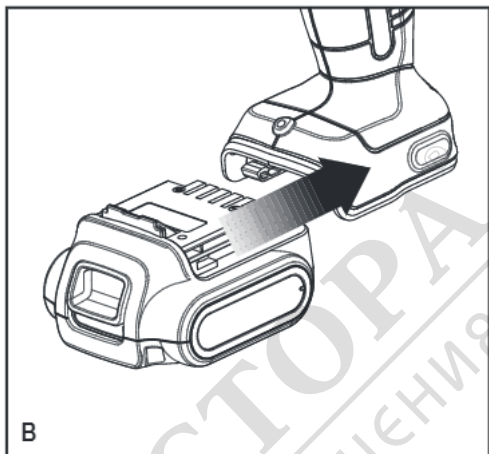
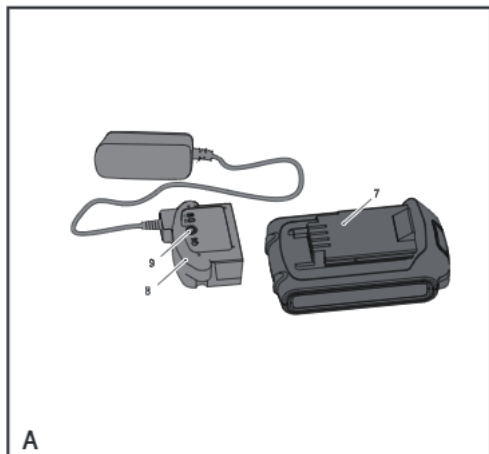

Intended use

Your BLACK+DECKER KFBCD600 - Drill, has been designed for screwdriving applications and for drilling in wood, metal and plastics. This tool is intended for consumer use only.

Safety instructions

General power tool safety warnings



Warning! Read all safety warnings and all instructions. Failure to follow the warnings and instructions listed below may result in electric shock, fire and/or serious injury.

Save all warnings and instructions for future reference.

The term "power tool" in all of the warnings listed below refers to your mains operated (corded) power tool or battery operated (cordless) power tool.

1. Work area safety

- Keep work area clean and well lit.** Cluttered or dark areas invite accidents.
- Do not operate power tools in explosive atmospheres, such as in the presence of flammable liquids, gases or dust.** Power tools create sparks which may ignite the dust or fumes.
- Keep children and bystanders away while operating a power tool.** Distractions can cause you to lose control.

2. Electrical safety

- Power tool plugs must match the outlet. Never modify the plug in any way. Do not use any adapter plugs with earthed (grounded) power tools.** Unmodified plugs and matching outlets will reduce risk of electric shock.
- Avoid body contact with earthed or grounded surfaces such as pipes, radiators, ranges and refrigerators.** There is an increased risk of electric shock if your body is earthed or grounded.
- Do not expose power tools to rain or wet conditions.** Water entering a power tool will increase the risk of electric shock.
- Do not abuse the cord. Never use the cord for carrying, pulling or unplugging the power tool. Keep cord away from heat, oil, sharp edges or moving parts.** Damaged or entangled cords increase the risk of electric shock.
- When operating a power tool outdoors, use an extension cord suitable for outdoor use.** Use of a cord suitable for outdoor use reduces the risk of electric shock.
- If operating a power tool in a damp location is unavoidable, use a residual current device (RCD) protected supply.** Use of an RCD reduces the risk of electric shock.

3. Personal safety

- Stay alert, watch what you are doing and use common sense when operating a power tool. Do not use a power tool while you are tired or under the influence of drugs, alcohol or medication.** A moment of inattention while operating power tools may result in serious personal injury.
 - Use personal protective equipment. Always wear eye protection.** Protective equipment such as dust mask, non-skid safety shoes, hard hat, or hearing protection used for appropriate conditions will reduce personal injuries.
 - Prevent unintentional starting. Ensure the switch is in the off-position before connecting to power source and/or battery pack, picking up or carrying the tool.** Carrying power tools with your finger on the switch or energising power tools that have the switch on invites accidents.
 - Remove any adjusting key or wrench before turning the power tool on.** A wrench or a key left attached to a rotating part of the power tool may result in personal injury.
 - Do not overreach. Keep proper footing and balance at all times.** This enables better control of the power tool in unexpected situations.
 - Dress properly. Do not wear loose clothing or jewellery. Keep your hair, clothing and gloves away from moving parts.** Loose clothes, jewellery or long hair can be caught in moving parts.
 - If devices are provided for the connection of dust extraction and collection facilities, ensure these are connected and properly used.** Use of dust collection can reduce dust-related hazards.
- #### 4. Power tool use and care
- Do not force the power tool. Use the correct power tool for your application.** The correct power tool will do the job better and safer at the rate for which it was designed.
 - Do not use the power tool if the switch does not turn it on and off.** Any power tool that cannot be controlled with the switch is dangerous and must be repaired.
 - Disconnect the plug from the power source and/or the battery pack from the power tool before making any adjustments, changing accessories, or storing power tools.** Such preventive safety measures reduce the risk of starting the power tool accidentally.
 - Store idle power tools out of the reach of children and do not allow persons unfamiliar with the power tool or these instructions to operate the power tool.** Power tools are dangerous in the hands of untrained users.

- e. **Maintain power tools.** Check for misalignment or binding of moving parts, breakage of parts and any other condition that may affect the power tools operation. If damaged, have the power tool repaired before use. Many accidents are caused by poorly maintained power tools.
- f. **Keep cutting tools sharp and clean.** Properly maintained cutting tools with sharp cutting edges are less likely to bind and are easier to control.
- g. **Use the power tool, accessories and tool bits etc. in accordance with these instructions, taking into account the working conditions and the work to be performed.** Use of the power tool for operations different from those intended could result in a hazardous situation.

5. Battery tool use and care

- a. **Recharge only with the charger specified by the manufacturer.** A charger that is suitable for one type of battery pack may create a risk of fire when used with another battery pack.
- b. **Use power tools only with specifically designated battery packs.** Use of any other battery packs may create a risk of injury and fire.
- c. **When battery pack is not in use, keep it away from other metal objects, like paper clips, coins, keys, nails, screws, or other small metal objects, that can make a connection from one terminal to another.** Shorting the battery terminals together may cause burns or a fire.
- d. **Under abusive conditions, liquid may be ejected from the battery; avoid contact. If contact accidentally occurs, flush with water. If liquid contacts eyes, additionally seek medical help.** Liquid ejected from the battery may cause irritation or burns.

6. Service

- a. **Have your power tool serviced by a qualified repair person using only identical replacement parts.** This will ensure that the safety of the power tool is maintained.

Additional power tool safety warnings



Warning! Additional safety warnings for drills

- ◆ **Use auxiliary handles supplied with the tool.** Loss of control can cause personal injury.
- ◆ **Hold power tool by insulated gripping surfaces when performing an operation where the cutting accessory may contact hidden wiring.** Cutting accessory contacting a "live" wire may make exposed metal parts of the power tool "live" and could give the operator an electric shock.

- ◆ **Hold power tool by insulated gripping surfaces, when performing an operation where the fastener may contact hidden wiring.** Fasteners contacting a "live" wire may make exposed metal parts of the power tool "live" and could give the operator an electric shock.
- ◆ **Use clamps or another practical way to secure and support the workpiece to a stable platform.** Holding the work by hand or against your body leaves it unstable and may lead to loss of control.
- ◆ Before drilling into walls, floors or ceilings, check for the location of wiring and pipes.
- ◆ Avoid touching the tip of a drill bit just after drilling, as it may be hot.
- ◆ The intended use is described in this instruction manual. The use of any accessory or attachment or performance of any operation with this tool other than those recommended in this instruction manual may present a risk of personal injury and/or damage to property.

Safety of others

- ◆ This tool is not intended for use by persons (including children) with reduced physical, sensory or mental capabilities, or lack of experience and knowledge, unless they have been given supervision or instruction concerning use of the tool by a person responsible for their safety.
- ◆ Children should be supervised to ensure that they do not play with the appliance.

Residual risks

Additional residual risks may arise when using the tool which may not be included in the enclosed safety warnings. These risks can arise from misuse, prolonged use etc.

Even with the application of the relevant safety regulations and the implementation of safety devices, certain residual risks can not be avoided. These include:

- ◆ Injuries caused by touching any rotating/moving parts.
- ◆ Injuries caused when changing any parts, blades or accessories.
- ◆ Injuries caused by prolonged use of a tool. When using any tool for prolonged periods ensure you take regular breaks.
- ◆ Impairment of hearing.
- ◆ Health hazards caused by breathing dust developed when using your tool (example:- working with wood, especially oak, beech and MDF.)

Vibration

The declared vibration emission values stated in the technical data and the declaration of conformity have been measured in accordance with a standard test method provided by EN 60745 and may be used for comparing one tool with another. The declared vibration emission value may also be used in a preliminary assessment of exposure.

Warning! The vibration emission value during actual use of the power tool can differ from the declared value depending on the ways in which the tool is used. The vibration level may increase above the level stated.

When assessing vibration exposure to determine safety measures required by 2002/44/EC to protect persons regularly using power tools in employment, an estimation of vibration exposure should consider, the actual conditions of use and the way the tool is used, including taking account of all parts of the operating cycle such as the times when the tool is switched off and when it is running idle in addition to the trigger time.

Labels on tool

The following symbols are shown on the tool along with the date code:



Warning! To reduce the risk of injury, the user must read the instruction manual.

Additional safety instructions for batteries and chargers (Not provided with the tool)

Batteries

- ◆ Never attempt to open for any reason.
- ◆ Do not expose the battery to water.
- ◆ Do not store in locations where the temperature may exceed 40 °C.
- ◆ Charge only at ambient temperatures between 10 °C and 40 °C.
- ◆ Charge only using the charger provided with the tool.
- ◆ When disposing of batteries, follow the instructions given in the section "Protecting the environment".



Do not attempt to charge damaged batteries.

Chargers

- ◆ Use your BLACK+DECKER charger only to charge the battery in the tool with which it was supplied. Other batteries could burst, causing personal injury and damage.
- ◆ Never attempt to charge non-rechargeable batteries.
- ◆ Have defective cords replaced immediately.
- ◆ Do not expose the charger to water.
- ◆ Do not open the charger.
- ◆ Do not probe the charger.



The charger is intended for indoor use only.



Read the instruction manual before use.

Electrical safety



Your charger is double insulated; therefore no earth wire is required. Always check that the mains voltage corresponds to the voltage on the rating plate. Never attempt to replace the charger unit with a regular mains plug. Ⓢ

- ◆ If the supply cord is damaged, it must be replaced by the manufacturer or an authorised BLACK+DECKER Service Centre in order to avoid a hazard.

Features

This tool includes some or all of the following features.

1. Variable speedswitch
2. Forward/reverse slider
3. Torque adjustment collar
4. Keyless chuck
5. Battery
6. Battery release button
7. Charger

Assembly

Use

Warning! Let the tool work at its own pace. Do not overload.

Charging the battery (fig. A)

The battery needs to be charged before first use and whenever it fails to produce sufficient power on jobs that were easily done before. The battery may become warm while charging; this is normal and does not indicate a problem.

Warning! Do not charge the battery at ambient temperatures below 10 °C or above 40 °C. Recommended charging temperature: approx. 24 °C.

Note: The charger will not charge a battery if the cell temperature is below approximately 10 °C or above 40 °C. The battery should be left in the charger and the charger will begin to charge automatically when the cell temperature warms up or cools down.

- ◆ Plug the charger (8) into any standard 230 Volts 50 Hz electrical outlet.
- ◆ Slide the battery pack into the charger as shown in figure A.
- ◆ The green LED (9) will flash indicating that the battery is being charged.
- ◆ The completion of charge is indicated by the green LED remaining on continuously. The pack is fully charged and may be used at this time or left on the charger.

Warning! Do not use tool while it is connected to the charger.

Warning! fire Hazard. When disconnecting the charger from the tool, be sure to unplug the charger from the outlet first, then disconnect the charger cord from the tool.

Installing and removing the battery pack from the tool (fig. B)

Warning! Make certain the lock-off button is engaged to prevent switch actuation before removing or installing battery. To install battery pack:

- ◆ Insert battery pack into tool, until an audible click is heard (fig. B)

Removing the battery pack from the tool (fig. C)

- ◆ Depress the battery release button as shown in (fig. C) and pull battery pack out of tool.

Operating Instructions

Trigger switch & reversing button (fig. D)

- ◆ The drill is turned ON and OFF by pulling and releasing the trigger switch (1). The farther the trigger is depressed, the higher the speed of the drill operates at
- ◆ A forward/reverse control button (2) determines the direction of the tool and also serves as a lock off button.
- ◆ To select forward rotation, release the trigger switch and depress the forward/reverse control button to the left.
- ◆ To select reverse, depress the forward/ reverse control button the opposite direction.
- ◆ To lock the tool, set the forward/reverse slider into the centre position.

Note! The center position of the control button locks the tool in the off position. When changing the position of the control button, be sure the trigger is released.

Torque control (fig. E)

This tool is fitted with a torque adjustment collar (3) to select the operating mode and to set the torque for tightening screws. Large screws and hard workpiece materials require a higher torque setting than small screws and soft workpiece materials.

- ◆ For drilling, set the collar to the drilling position symbol 
- ◆ For screwdriving, set the collar to the desired setting. If you do not yet know the appropriate setting, proceed as follows:
 - ◆ Set the collar to the lowest torque setting.
 - ◆ Tighten the first screw.
 - ◆ If the clutch ratchets before the desired result is achieved, increase the collar setting and continue tightening the screw. Repeat until you reach the correct setting. Use this setting for the remaining screws

Keyless chuck (fig. F)

Warning! Make certain the lock-off button is engaged to prevent switch actuation before installing or removing accessories.

To insert a drill bit or other accessory:

- ◆ Grasp the rear half of the chuck with one hand and use your other hand to rotate the front half in the counterclockwise direction, as viewed from the chuck end.
- ◆ Insert the bit or other accessory fully into the chuck, and tighten securely by holding the rear half of the chuck and rotating the front portion in the clockwise direction as viewed from the chuck end.

Warning! Do not attempt to tighten drill bits (or any other accessory) by gripping the front part of the chuck and turning the tool on. Damage to the chuck and personal injury may occur when changing accessories.

Drilling/screwdriving

- ◆ Select forward or reverse rotation using the forward/reverse slider (2).
- ◆ To switch the tool on, press the switch (1). The tool speed depends on how far you press the switch.
- ◆ To switch the tool off, release the switch.

Hints for optimum use

Drilling

- ◆ Always apply a light pressure in a straight line with the drill bit.
- ◆ Just before the drill tip breaks through the other side of the workpiece, decrease pressure on the tool.
- ◆ Use a block of wood to back up workpieces that may splinter.
- ◆ Use spade bits when drilling large diameter holes in wood.
- ◆ Use HSS drill bits when drilling in metal.
- ◆ Use masonry bits when drilling in soft masonry.
- ◆ Use a lubricant when drilling metals other than cast iron and brass.
- ◆ Make an indentation using a centre punch at the centre of the hole to be drilled in order to improve accuracy.

Screwdriving

- ◆ Always use the correct type and size of screwdriver bit.
- ◆ If screws are difficult to tighten, try applying a small amount of washing liquid or soap as a lubricant.
- ◆ Always hold the tool and screwdriver bit in a straight line with the screw

Troubleshooting

Problem	Possible cause	Possible solution
Unit will not start.	Battery pack not charged.	Check battery pack charging requirements

Problem	Possible cause	Possible solution
Battery pack will not charge.	Charger not plugged in. Surrounding air temperature too hot or too cold.	Plug charger into a working outlet. Move charger and battery pack to a surrounding air temperature of above 40 degrees F (45°C) or below 105 degrees F (+40.5°C)
Unit shuts off abruptly.	Battery pack has reached its maximum thermal limit. Out of charge. (To maximize the life of the battery pack it is designed to shut off abruptly when the charge is depleted)	Allow battery pack to cool down. Place on charger and allow to charge.

Technical data

KFBCD800		
Voltage	V_{DC}	10.8
No-load speed	Min^{-1}	0-550rpm
Max. torque	Nm	12.5/26
Chuck capacity	mm	1-10
Max Drilling capacity		
Steel/wood	mm	10/25
Weight	kg	0.98

Charger		
Input voltage	V_{AC}	230
Output voltage	V_{DC}	10.8
Current	mA	200mA
Approx. charge time	Hours	8

Maintenance

Your BLACK+DECKER tool has been designed to operate over a long period of time with a minimum of maintenance. Continuous satisfactory operation depends upon proper tool care and regular cleaning.

Your charger does not require any maintenance apart from regular cleaning.

Warning! Before performing any maintenance on the tool, remove the battery from the tool. Unplug the charger before cleaning it.

- ◆ Regularly clean the ventilation slots in your tool and charger using a soft brush or dry cloth.
- ◆ Regularly clean the motor housing using a damp cloth. Do not use any abrasive or solvent-based cleaner.
- ◆ Regularly open the chuck and tap it to remove any dust from the interior.

Protecting the environment



Separate collection. Products and batteries marked with this symbol must not be disposed of with normal household waste.

Products and batteries contain materials that can be recovered or recycled reducing the demand for raw materials.

Please recycle electrical products and batteries according to local provisions. Further information is available at www.2helpU.com.

EC declaration of conformity

MACHINERY DIRECTIVE



KFBCD600 - Drill, Screwdriver

Black & Decker declares that these products described under "technical data" are in compliance with:
2006/42/EC, EN 60745-1, EN 60745-2-1, EN60745-2-2

These products also comply with Directive 2004/108/EC (until 19/04/2016) 2014/30/EU (from 20/04/2016) and 2011/65/EU. For more information, please contact Black & Decker at the following address or refer to the back of the manual. The undersigned is responsible for compilation of the technical file and makes this declaration on behalf of

Black & Decker.

R. Laverick
Engineering Manager
Black & Decker Europe, 210 Bath Road, Slough,
Berkshire, SL1 3YD
United Kingdom
14/07/2015

Charger		
Input voltage	V_{AC}	230
Output voltage	V_{DC}	10.8
Current	mA	400
Approx. charge time	Hours	3-5

Charger		
Input voltage	V_{AC}	230
Output voltage	V_{DC}	10.8
Current	Amp	1
Approx. charge time	Hours	1.5

Battery		BL1512
Voltage	V_{AC}	10.8
Capacity	Ah	1.5
Type		Li-Ion

Level of sound pressure according to EN 60745:	
Sound pressure (L_{pA})	63 dB(A), uncertainty (K) 3 dB(A)
Sound power (L_{WA})	74 dB(A), uncertainty (K) 3 dB(A)

Vibration total values (triax vector sum) according to EN 60745:	
Drilling into metal ($a_{h,D}$)	$<2.5 \text{ m/s}^2$, uncertainty (K) 1.5 m/s^2
Screwdriving without impact (a_h)	$<2.5 \text{ m/s}^2$, uncertainty (K) 1.5 m/s^2



Guarantee

Black & Decker is confident of the quality of its products and offers consumers a 24 month guarantee from the date of purchase. This guarantee is in addition to and in no way prejudices your statutory rights. The guarantee is valid within the territories of the Member States of the European Union and the European Free Trade Area.

To claim on the guarantee, the claim must be in accordance with Black & Decker Terms and Conditions and you will need to submit proof of purchase to the seller or an authorised repair agent. Terms and conditions of the Black & Decker 2 year guarantee and the location of your nearest authorised repair agent can be obtained on the Internet at www.2helpU.com, or by contacting your local Black & Decker office at the address indicated in this manual.

Please visit our website www.blackanddecker.co.uk to register your new Black & Decker product and receive updates on new products and special offers



МАГАЗИН
БАШ МАЙСТОРА®
ПРОФЕСИОНАЛНИ РЕШЕНИЯ



МАГАЗИН
БАШ МАЙСТОРА®
ПРОФЕСИОНАЛНИ РЕШЕНИЯ



МАГАЗИН
БАШ МАЙСТОРА[®]
ПРОФЕСИОНАЛНИ РЕШЕНИЯ

Australia	Black & Decker (Australia) Pty. Ltd. 20 Fletcher Road, Mooroolbark, Victoria, 3138	Tel. Fax	03-8720 5100 03-9727 5940
New Zealand	Black & Decker 5 Te Apunga Place Mt Wellington Auckland 1060	Tel. Fax	+64 9 259 1133 +64 9 259 1122
United Kingdom & Republic Of Ireland www.blackanddecker.co.uk emeaservice@sbdinc.com	Black & Decker 210 Bath Road Slough, Berkshire SL1 3YD	Tel. Fax	01753 511234 01753 512365



МАГАЗИН
БАШ МАЙСТОРА[®]
 ПРОФЕСИОНАЛНИ РЕШЕНИЯ