

D	Originalbetriebsanleitung Akku-Heckenschere	FIN	Alkuperäiskäyttöohje Akkukäyttöiset pensassakset
GB	Original operating instructions Cordless hedge trimmer	SLO	Originalna navodila za uporabo Baterijske škarje za živo mejo
F	Instructions d'origine Taille-haies a accumulateur	H	Eredeti használati utasítás Akku-kerti olló
I	Istruzioni per l'uso originali Cesoie per siepi a batteria	RO	Instrucțiuni de utilizare originale Foarfece pentru gard viu cu acumulator
DK/ N	Original betjeningsvejledning Akku-hækkeklipper	GR	Πρωτότυπες Οδηγίες χρήσης Θαμνοκοπτης μπαταρίας
S	Original-bruksanvisning Batteridrivnen häcksax	P	Manual de instrucções original Corta-sebes sem fio
CZ	Originální návod k obsluze Akumulátorové plotové nůžky	HR/ BIH	Originalne upute za uporabu Akumulatorske škare za živicu
SK	Originálny návod na obsluhu Akumulátorové záhradnícke nožnice	RS	Originalna uputstva za upotrebu Akumulatorske makaze za živicu
NL	Originele handleiding Accuheggenchaar	PL	Instrukcją oryginalną Akumulatorowe nożyce
E	Manual de instrucciones original Tijeras recortasetos de pilas recargables	TR	Orijinal Kullanma Talimatı Şarjlı çit makası
		EE	Originaalkasutusjuhend Akuhekilõikur

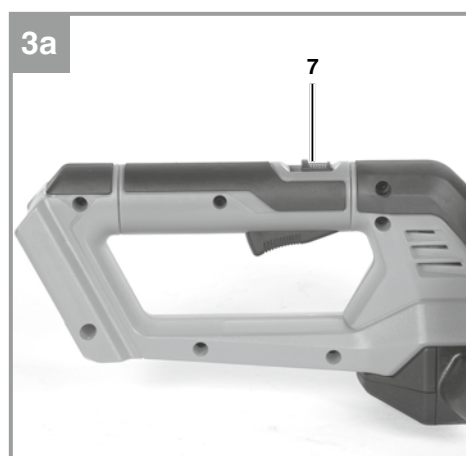

Art.-Nr.: 34.109.45

I.-Nr.: 21011

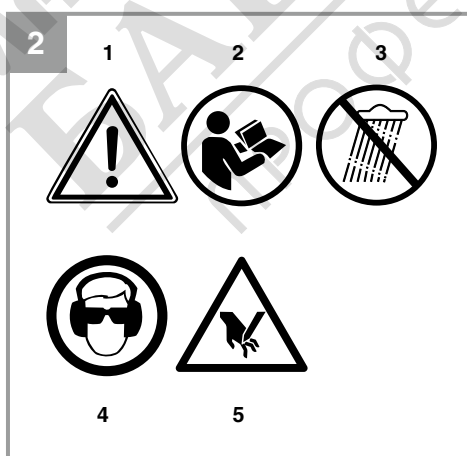

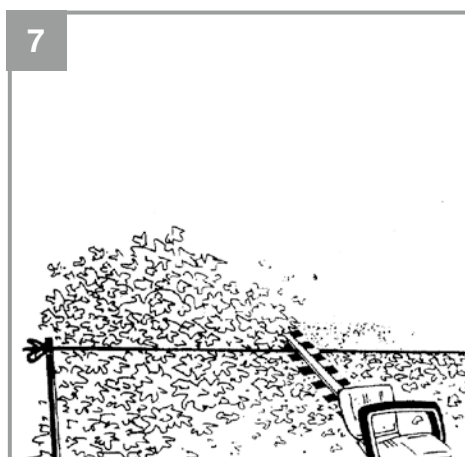
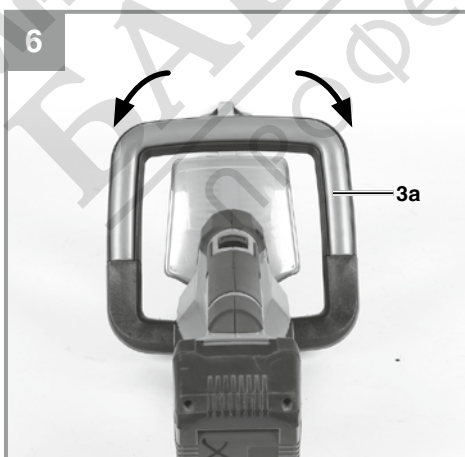
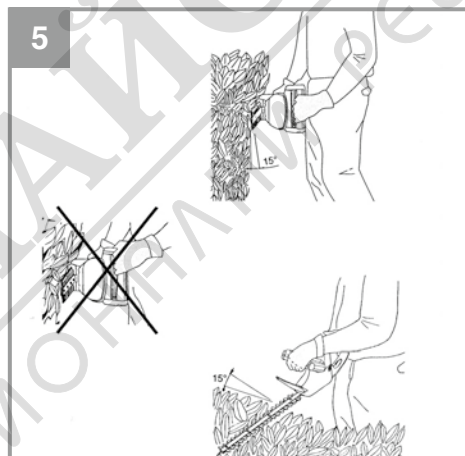
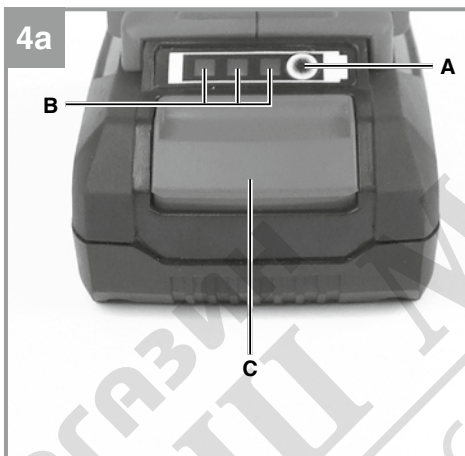
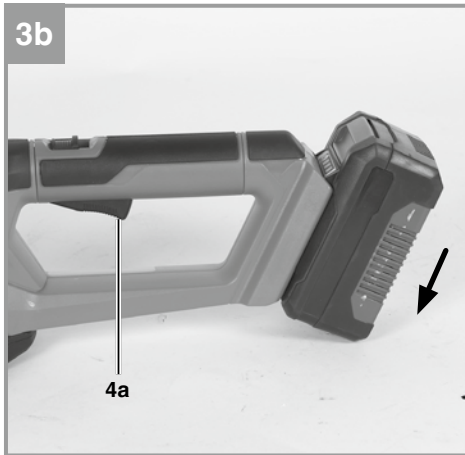

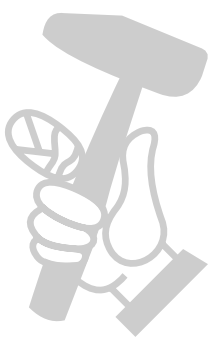
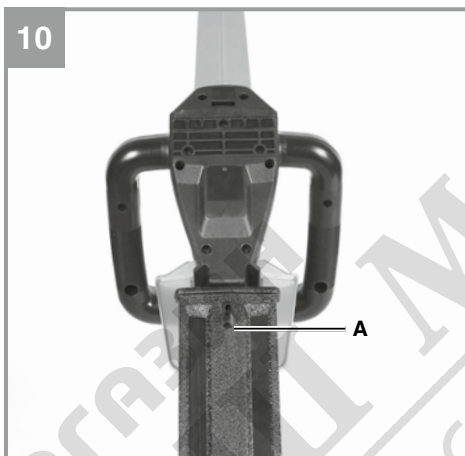
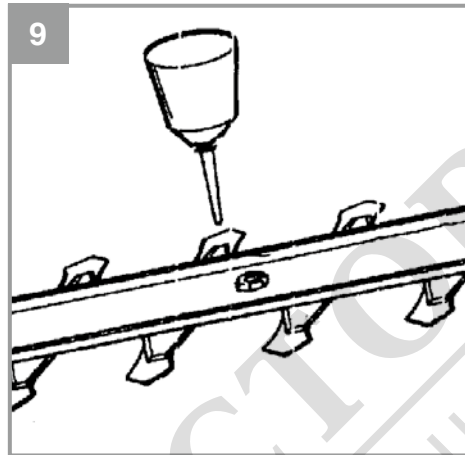
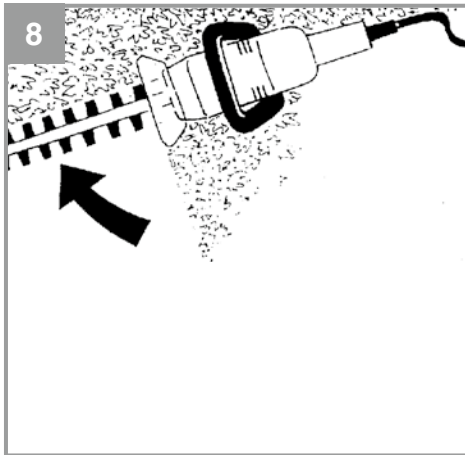

Danger!

When using the equipment, a few safety precautions must be observed to avoid injuries and damage. Please read the complete operating instructions and safety regulations with due care. Keep this manual in a safe place, so that the information is available at all times. If you give the equipment to any other person, hand over these operating instructions and safety regulations as well. We cannot accept any liability for damage or accidents which arise due to a failure to follow these instructions and the safety instructions.

Explanation of the warning signs on the equipment (see Fig. 2)

- 1: Warning
- 2: Read the instruction manual before starting.
- 3: Protect against moisture.
- 4: Wear eye protection and ear plugs.
- 5: **Danger!** Moving blade. Keep hands and feet away from the blade.

1. Safety regulations

The corresponding safety information can be found in the enclosed booklet.

Danger!**Read all safety regulations and instructions.**

Any errors made in following the safety regulations and instructions may result in an electric shock, fire and/or serious injury.

Keep all safety regulations and instructions in a safe place for future use.**2. Layout and items supplied****2.1 Layout (Fig. 1)**

1. Cutter rail
2. Hand guard
3. Steady grip with button switch
4. Handle with button switch
5. Cutter guard
6. Impact guard
7. Lock for handle

2.2 Items supplied

Please check that the article is complete as specified in the scope of delivery. If parts are missing, please contact our service center or the sales outlet where you made your purchase at the latest within 5 working days after purchasing the product and upon presentation of a valid bill of purchase. Also, refer to the warranty table in the service information at the end of the operating instructions.

- Open the packaging and take out the equipment with care.
- Remove the packaging material and any packaging and/or transportation braces (if available).
- Check to see if all items are supplied.
- Inspect the equipment and accessories for transport damage.
- If possible, please keep the packaging until the end of the guarantee period.

Danger!

The equipment and packaging material are not toys. Do not let children play with plastic bags, foils or small parts. There is a danger of swallowing or suffocating!

- Hedge trimmer
- Cutter guard
- Original operating instructions
- Safety instructions

3. Proper use

This hedge trimmer is suitable for cutting hedges, bushes and shrubs.

The equipment is to be used only for its prescribed purpose. Any other use is deemed to be a case of misuse. The user / operator and not the manufacturer will be liable for any damage or injuries of any kind caused as a result of this.

Please note that our equipment has not been designed for use in commercial, trade or industrial applications. Our warranty will be voided if the machine is used in commercial, trade or industrial businesses or for equivalent purposes.

4. Technical data

Rated voltage.....	18 V d.c.
Cutter rail length	550 mm
Cutting length	500 mm
Tooth spacing	17 mm
Cuts/min.	2400
Sound pressure level L_{pA}	71 dB(A)
Sound power level L_{WA}	91 dB(A)
Uncertainty K_{pA} / K_{WA}	3 dB
Sound power level guaranteed L_{WA}	96 dB(A)
Vibrations a_h	$\leq 2.5 \text{ m/s}^2$
Uncertainty K	1.5 m/s^2
Weight:	2.2 kg

Caution

The equipment is supplied without batteries and without a charger. It must only be used with the lithium-ion batteries in the Power X-Change series.

The lithium-ion batteries of the Power X-Change series must only be charged only with the Power X charger.

Wear ear-muffs.

The impact of noise can cause damage to hearing.

The stated vibration emission levels and stated noise emission values were measured in accordance with a set of standardized criteria and can be used to compare one power tool with another.

The stated vibration emission levels and stated noise emission values can also be used to make an initial assessment of exposure.

Warning:

The vibration and noise emission levels may vary from the level specified during actual use, depending on the way in which the power tool is used, especially the type of workpiece it is used for.

Keep the noise emissions and vibrations to a minimum.

- Only use appliances which are in perfect working order.
- Service and clean the appliance regularly.
- Adapt your working style to suit the appliance.
- Do not overload the appliance.
- Have the appliance serviced whenever necessary.

- Switch the appliance off when it is not in use.
- Wear protective gloves.

Caution!

Residual risks

Even if you use this electric power tool in accordance with instructions, certain residual risks cannot be ruled out. The following hazards may arise in connection with the equipment's construction and layout:

1. Lung damage if no suitable protective dust mask is used.
2. Damage to hearing if no suitable ear protection is used.
3. Health damage caused by hand-arm vibrations if the equipment is used over a prolonged period or is not properly guided and maintained.

Limit the operating time!

All stages of the operating cycle must be considered (for example, times in which the electric tools are switched off and times in which the tool is switched on but operates without load).

5. Before starting the equipment

The equipment is supplied without batteries and without a charger.

Rotatable handle

The hedge trimmer is fitted with a rotatable rear handle. It can be rotated 90° to the left and right. To do this, pull the slide (Fig. 3a / item 7) in the direction of the arrow and rotate the handle.

To return the handle to its original position, pull the slide (Fig. 3a / item 7) back in the direction of the arrow. The handle should be rotated through 90° when performing vertical cuts.

Installing the battery pack (Fig. 3b)

Press the pushlock button (Fig. 4a/Item C) of the rechargeable battery and push the rechargeable battery into the mount provided. Make sure that the pushlock button engages properly! To remove the battery, proceed in reverse order!

Charging the battery (Fig. 4)

1. Take the battery pack out of the equipment. Press the push/lock button to do this.
2. Check that your mains voltage matches the voltage specified on the rating plate of the battery charger. Insert the power plug of the charger into the socket outlet. The green LED

- will then begin to flash.
3. Insert the battery pack into the charger.
 4. In the section entitled „Charger indicator“ there is a table with an explanation of the LED display on the charger.

The battery pack can heat up slightly during charging. This is normal.

If the battery pack fails to charge, please check:

- whether there is a voltage at the mains power socket;
- whether there is good contact at the charging contacts.

If the battery pack still fails to charge, please send

- the charging unit
 - and the battery pack
- to our customer service center.

To ensure that items are properly packaged and delivered when you send them to us, please contact our customer service or the point of sale at which the equipment was purchased.

When shipping or disposing of batteries and cordless tools, always ensure that they are packed individually in plastic bags to prevent short circuits and fires.

To ensure that the battery pack provides long service, you should take care to recharge it promptly. You must recharge the battery pack when you notice that the performance of the device drops. Never allow the battery pack to become fully discharged. This will cause it to develop a defect.

Battery capacity indicator (Fig. 4a)

Press the battery capacity indicator switch (item A). The battery capacity indicator (item B) shows the charge status of the battery using 3 LEDs.

All 3 LEDs are lit:

The battery is fully charged.

2 or 1 LED(s) are lit:

The battery has an adequate remaining charge.

1 LED flashes:

The battery is empty, recharge the battery.

All LEDs blink:

The battery temperature is too low. Remove the battery from the equipment, keep it at room temperature for one day. If the fault reoccurs, this me-

ans that the rechargeable battery has undergone exhaustive discharge and is defective. Remove the battery from the equipment. Never use or charge a defective battery.

6. Operation

Switching ON/OFF.

The hedge trimmer is equipped with a two-handed safety switch. It works only when the switch on the steady grip (Fig. 6/Item 3a) is pressed with one hand and the switch (Fig. 3b/Item 4a) on the handle is pressed with the other hand. If either switch is released, the cutters will stop moving. Please watch out for the cutters as they slow down to a standstill.

Notes for use

- A hedge trimmer can be used to cut shrubs and bushes as well as hedges.
- To obtain the best cutting results, hold the hedge trimmer so that the cutter teeth are at an angle of approx. 15° in relation to the hedge (see Fig. 5).
- The twin-bladed cutters rotate in opposite directions, thus enabling cutting in both directions (see Fig. 6).
- To ensure that you cut the hedge to a level height, we recommend tying a guide line of string or similar along the hedge. Cut off all branches that protrude beyond the guide line (see Fig. 7).

Warning! Be particularly attentive when cutting along the guide line. Do not cut through the guide line. This could get entangled in the blades and lead to injuries or damage to property.

- Cut the sides of the hedge with curve-shaped movements from the bottom up (see Figure 8).

What to do if the blade gets blocked

1. Stop the equipment.
2. Remove the battery.
3. Remove the jammed material from the blade (wear work gloves to prevent injury when you do so).

After using

1. Switch off the equipment.
2. Remove the battery.
3. Allow the equipment to cool down and then

store it out of children's reach.

7. Cleaning, maintenance and ordering of spare parts

Danger!

Before putting the hedge trimmer away and cleaning it, switch it off and remove the battery pack.

7.1 Cleaning

- Keep all safety devices, air vents and the motor housing free of dirt and dust as far as possible. Wipe the equipment with a clean cloth or blow it with compressed air at low pressure.
- We recommend that you clean the device immediately each time you have finished using it.
- Clean the equipment regularly with a moist cloth and some soft soap. Do not use cleaning agents or solvents; these could attack the plastic parts of the equipment. Ensure that no water can seep into the device. The ingress of water into an electric tool increases the risk of an electric shock.
- Use a brush to remove deposits from the safety guard.

7.2 Maintenance

- The cutters should be cleaned and lubricated at regular intervals in order to ensure best performance at all times. Remove deposits with a brush and apply a thin film of oil (Fig. 9).
- There are no other parts inside the equipment that require maintenance.
- Double blades are not allowed to be used if they are damaged or worn and must be replaced by original spare parts from the manufacturer.
- Arrange for an expert or our service workshop to carry out all safety-related maintenance work and the replacement of defective parts or the sharpening or replacement of the double blade, so that you can be sure that the hedge trimmer is safe to use.

7.3 Storage

- When not in use the hedge trimmer can be hung on a nail, screw or the like for storage, with the cutter rail guard fitted (Fig. 10/Item. A).

7.4 Ordering replacement parts:

Please quote the following data when ordering replacement parts:

- Type of machine
- Article number of the machine
- Identification number of the machine
- Replacement part number of the part required

For our latest prices and information please go to www.Einhell-Service.com

8. Disposal and recycling

The equipment is supplied in packaging to prevent it from being damaged in transit. The raw materials in this packaging can be reused or recycled. The equipment and its accessories are made of various types of material, such as metal and plastic. Never place defective equipment in your household refuse. The equipment should be taken to a suitable collection center for proper disposal. If you do not know the whereabouts of such a collection point, you should ask in your local council offices.

9. Faults

Check that the battery is charged and the charging unit is working. If the equipment will not work despite the voltage supply being present, please send it to the customer service address below.

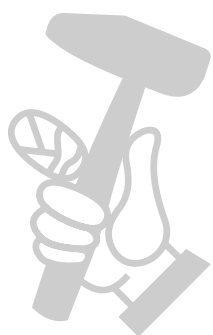

10. Charger indicator

Indicator status		Explanations and actions
Red LED	Green LED	
Off	Flashing	<p>Ready for use The charger is connected to the mains and is ready for use; there is no battery pack in the charger</p>
On	Off	<p>Charging The charger is charging the battery pack in quick charge mode. The charging times are shown directly on the charger. Important! The actual charging times may vary slightly from the stated charging times depending on the existing battery charge.</p>
Off	On	<p>The battery is charged and ready for use. (READY TO GO) The unit then changes over to gentle charging mode until the battery is fully charged. To do this, leave the rechargeable battery on the charger for approx. 15 minutes longer. Action: Take the battery pack out of the charger. Disconnect the charger from the mains supply.</p>
Flashing	Off	<p>Adapted charging The charger is in gentle charging mode. For safety reasons the charging is performed less quickly and takes more time. The reasons can be: - The rechargeable battery has not been used for a very long time. - The battery temperature is outside the ideal range. Action: Wait for the charging to be completed; you can still continue to charge the battery pack.</p>
Flashing	Flashing	<p>Fault Charging is no longer possible. The battery pack is defective. Action: Never charge a defective battery pack. Take the battery pack out of the charger.</p>
On	On	<p>Temperature fault The battery pack is too hot (e.g. due to direct sunshine) or too cold (below 0° C). Action: Remove the battery pack and keep it at room temperature (approx. 20° C) for one day .</p>



For EU countries only

Never place any electric power tools in your household refuse.

To comply with European Directive 2012/19/EC concerning old electric and electronic equipment and its implementation in national laws, old electric power tools have to be separated from other waste and disposed of in an environment-friendly fashion, e.g. by taking to a recycling depot.

Recycling alternative to the return request:

As an alternative to returning the equipment to the manufacturer, the owner of the electrical equipment must make sure that the equipment is properly disposed of if he no longer wants to keep the equipment. The old equipment can be returned to a suitable collection point that will dispose of the equipment in accordance with the national recycling and waste disposal regulations. This does not apply to any accessories or aids without electrical components supplied with the old equipment.

Please note that batteries and lamps (e.g. light bulbs) must be removed from the tool before it is disposed of.

The reprinting or reproduction by any other means, in whole or in part, of documentation and papers accompanying products is permitted only with the express consent of the Einhell Germany AG.

Subject to technical changes

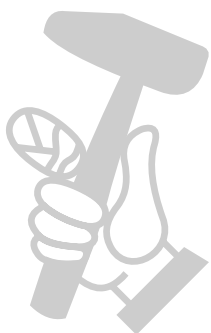

Service information

We have competent service partners in all countries named on the guarantee certificate whose contact details can also be found on the guarantee certificate. These partners will help you with all service requests such as repairs, spare and wearing part orders or the purchase of consumables.

Please note that the following parts of this product are subject to normal or natural wear and that the following parts are therefore also required for use as consumables.

Category	Example
Wear parts*	Blade guide, Battery
Consumables*	Blade
Missing parts	

* Not necessarily included in the scope of delivery!

In the effect of defects or faults, please register the problem on the internet at www.Einhell-Service.com. Please ensure that you provide a precise description of the problem and answer the following questions in all cases:

- Did the equipment work at all or was it defective from the beginning?
- Did you notice anything (symptom or defect) prior to the failure?
- What malfunction does the equipment have in your opinion (main symptom)? Describe this malfunction.

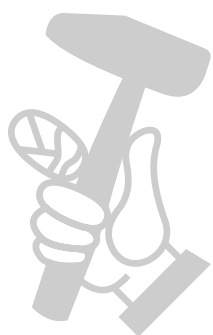

Warranty certificate

Dear Customer,

All of our products undergo strict quality checks to ensure that they reach you in perfect condition. In the unlikely event that your device develops a fault, please contact our service department at the address shown on this guarantee card. You can also contact us by telephone using the service number shown. Please note the following terms under which guarantee claims can be made:

1. These guarantee terms apply to consumers only, i.e. natural persons intending to use this product neither for their commercial activities nor for any other self-employed activities. These warranty terms regulate additional warranty services, which the manufacturer mentioned below promises to buyers of its new products in addition to their statutory rights of guarantee. Your statutory guarantee claims are not affected by this guarantee. Our guarantee is free of charge to you.
2. The warranty services cover only defects due to material or manufacturing faults on a product which you have bought from the manufacturer mentioned below and are limited to either the rectification of said defects on the product or the replacement of the product, whichever we prefer. Please note that our devices are not designed for use in commercial, trade or professional applications. A guarantee contract will not be created if the device has been used by commercial, trade or industrial business or has been exposed to similar stresses during the guarantee period.
3. The following are not covered by our guarantee:
 - Damage to the device caused by a failure to follow the assembly instructions or due to incorrect installation, a failure to follow the operating instructions (for example connecting it to an incorrect mains voltage or current type) or a failure to follow the maintenance and safety instructions or by exposing the device to abnormal environmental conditions or by lack of care and maintenance.
 - Damage to the device caused by abuse or incorrect use (for example overloading the device or the use of unapproved tools or accessories), ingress of foreign bodies into the device (such as sand, stones or dust, transport damage), the use of force or damage caused by external forces (for example by dropping it).
 - Damage to the device or parts of the device caused by normal or natural wear or tear or by normal use of the device.
4. The guarantee is valid for a period of 24 months starting from the purchase date of the device. Guarantee claims should be submitted before the end of the guarantee period within two weeks of the defect being noticed. No guarantee claims will be accepted after the end of the guarantee period. The original guarantee period remains applicable to the device even if repairs are carried out or parts are replaced. In such cases, the work performed or parts fitted will not result in an extension of the guarantee period, and no new guarantee will become active for the work performed or parts fitted. This also applies if an on-site service is used.
5. To make a claim under the guarantee, please register the defective device at: www.Einhell-Service.com. Please keep your bill of purchase or other proof of purchase for the new device. Devices that are returned without proof of purchase or without a rating plate shall not be covered by the guarantee, because appropriate identification will not be possible. If the defect is covered by our guarantee, then the item in question will either be repaired immediately and returned to you or we will send you a new replacement.

Of course, we are also happy offer a chargeable repair service for any defects which are not covered by the scope of this guarantee or for units which are no longer covered. To take advantage of this service, please send the device to our service address.

Also refer to the restrictions of this warranty concerning wear parts, consumables and missing parts as set out in the service information in these operating instructions.