

DEWALT®

XR®

Dansk (oversat fra original brugsvejledning)	7
Deutsch (Übersetzung der Originalanweisung)	17
English (original instructions)	28
Español (traducido de las instrucciones originales)	38
Français (traduction de la notice d'instructions originale)	49
Italiano (tradotto dalle istruzioni originali)	60
Nederlands (vertaald vanuit de originele instructies)	71
Norsk (oversatt fra de originale instruksjonene)	82
Português (traduzido das instruções originais)	92
Suomi (käännetty alkuperäisestä käyttöohjeesta)	103
Svenska (översatt från de ursprungliga instruktionerna)	113
Türkçe (orijinal talimatlardan çevrilmiştir)	123
Ελληνικά (μετάφραση από τις πρωτότυπες οδηγίες)	133



Fig. A

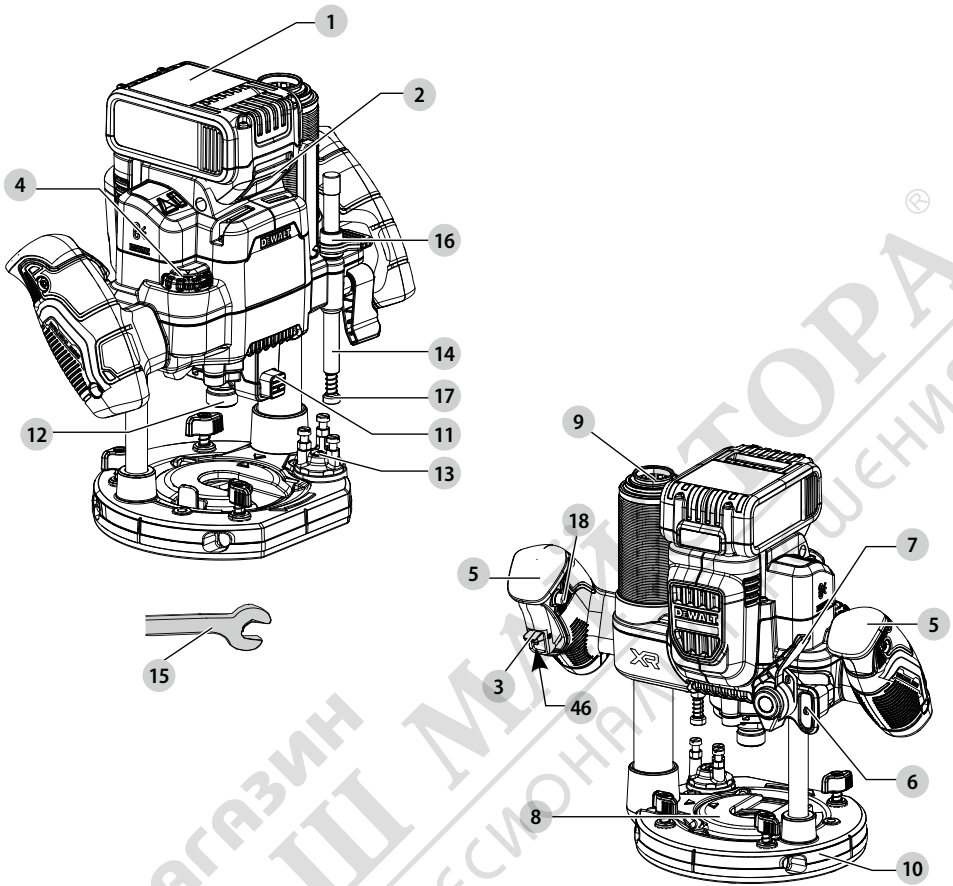

Fig. B

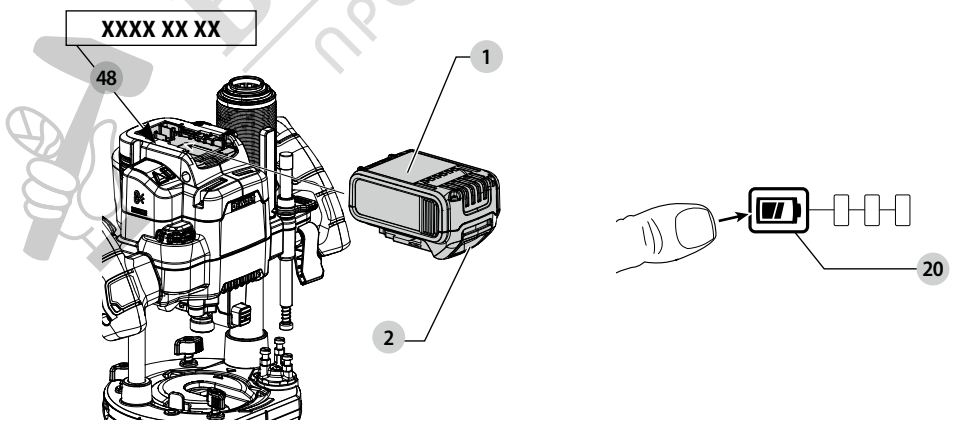

Fig. C

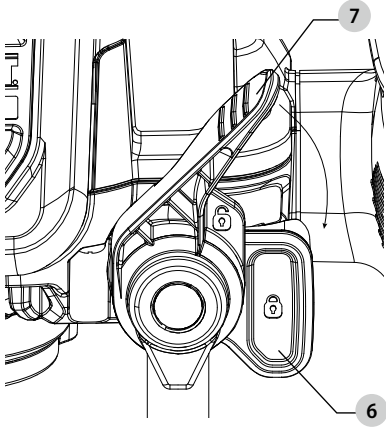

Fig. D

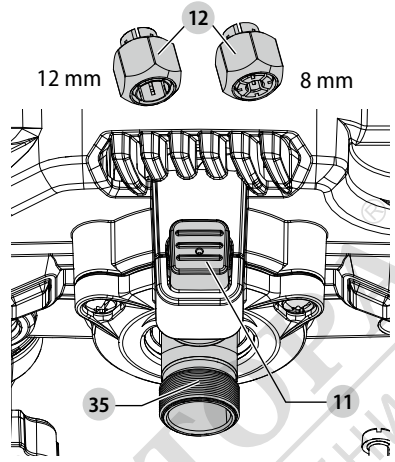

Fig. E

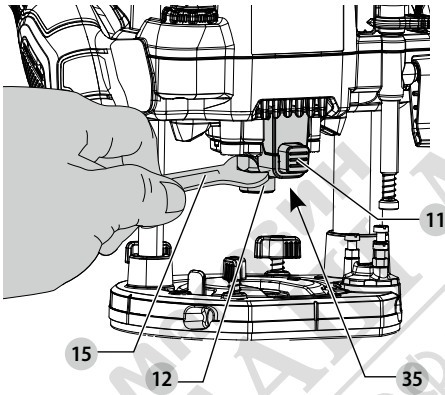

Fig. F

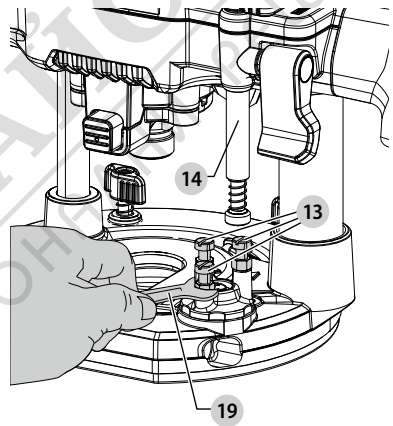

Fig. G

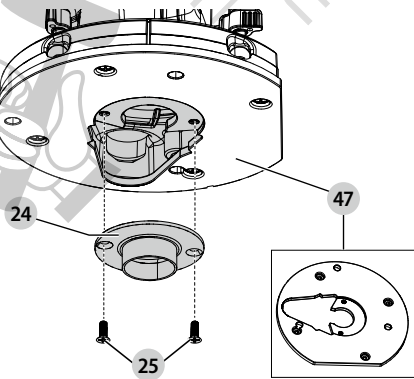

Fig. H

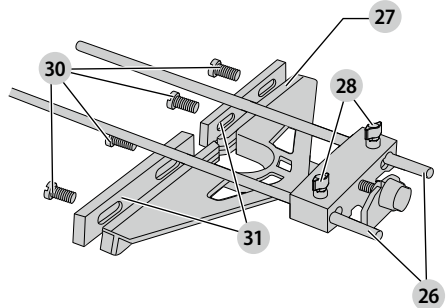

Fig. I

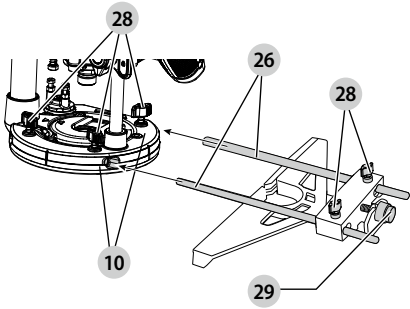

Fig. J

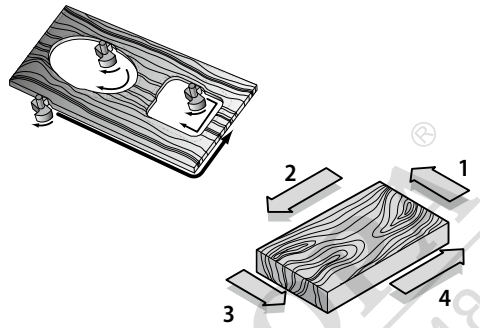

Fig. K

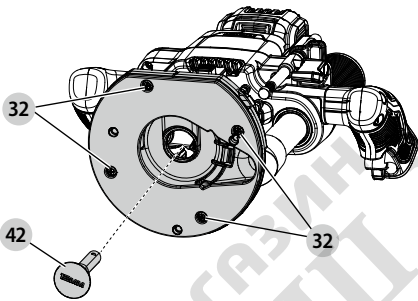

Fig. L

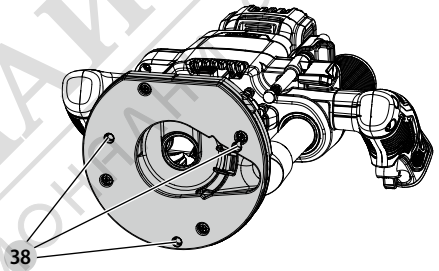

Fig. M

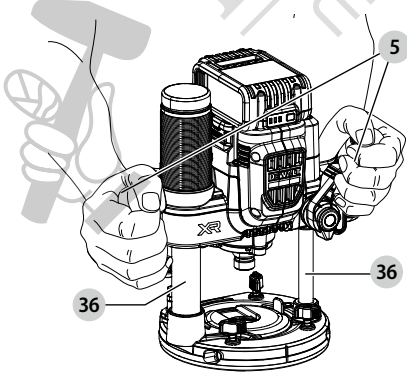

Fig. N

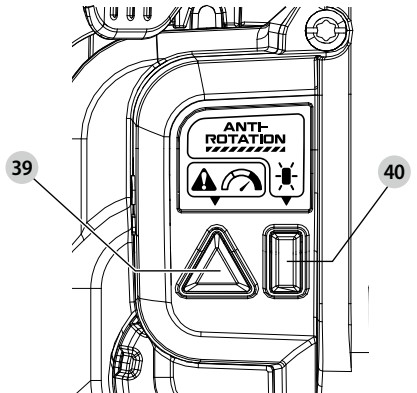

Fig. 01

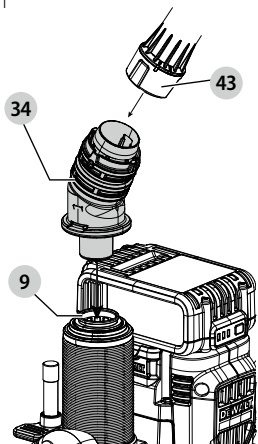

Fig. 02

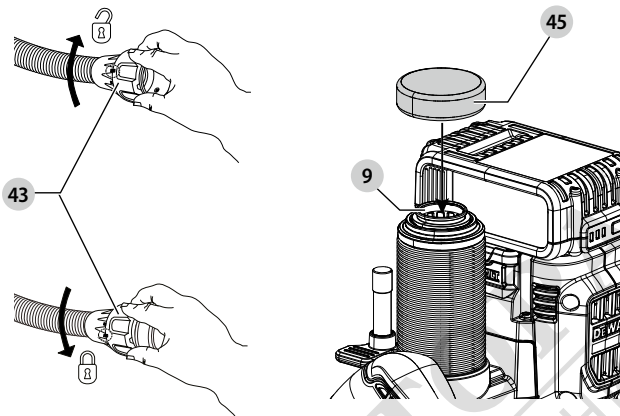

Fig. P

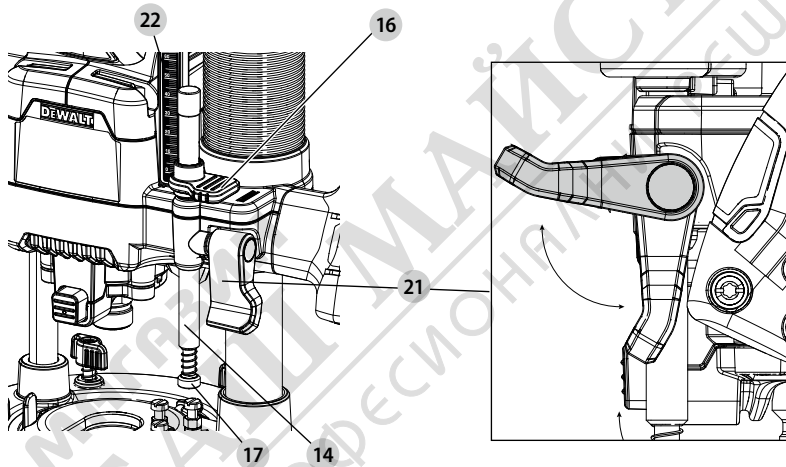

Fig. Q1

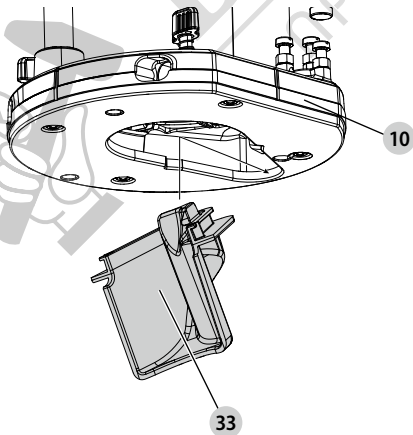

Fig. Q2

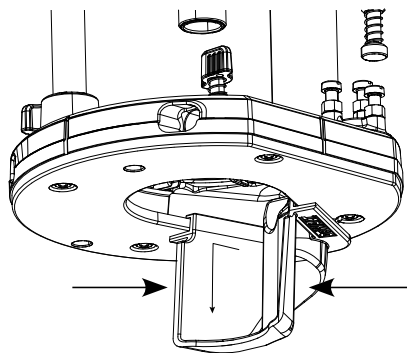

Fig. R1

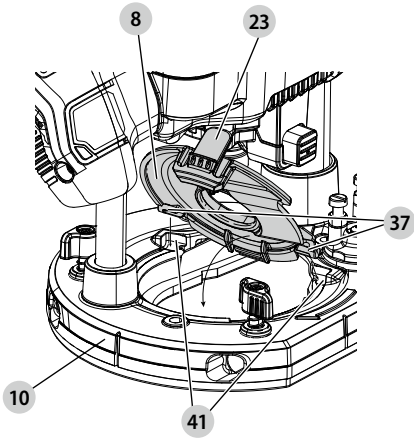

Fig. R2

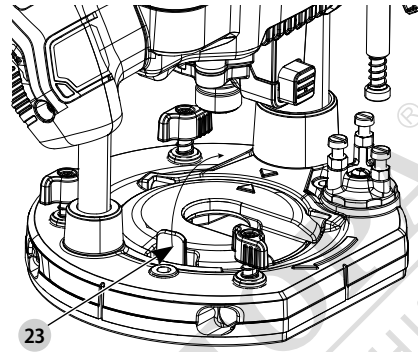

Fig. R3

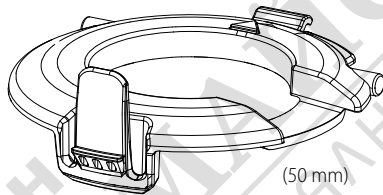
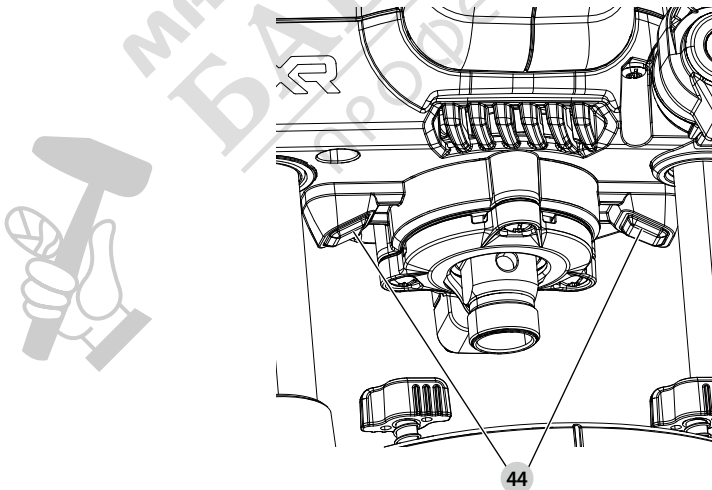



Fig. S



18V MAX* PLUNGE ROUTER

DCW620

 **WARNING:** Read all safety warnings, instructions, illustrations, and specifications in this manual, including the battery and charger sections provided in an original tool manual or the separate Batteries and Chargers manual. Manuals can be obtained by contacting Customer Service (refer to the back page of this manual).

Technical Data

		DCW620
Voltage	V_{DC}	18V
Type		1
No-load speed	min^{-1}	11000 - 23000
Plunging stroke	mm	70
Max. Bit diameter	mm	63
Collet size	mm	8/12
Weight (without battery)	kg	3.62
Wireless Tool Control Transmitter		
Frequency Band	MHz	433
Max. Power (EIRP)	mW	0.03

Noise values and/or vibration values (triax vector sum) according to EN62841-2-17:

L_{PA} (emission sound pressure level)	dB(A)	73.8
L_{WA} (sound power level)	dB(A)	84.8
K (uncertainty for the given sound level)	dB(A)	2.5
Vibration emission value $a_{h,hv} =$		
	m/s^2	4.4
Uncertainty K =	m/s^2	1.1

The vibration and/or noise emission level given in this information sheet has been measured in accordance with a standardised test given in EN62841 and may be used to compare one tool with another. It may be used for a preliminary assessment of exposure.

 **WARNING:** The declared vibration and/or noise emission level represents the main applications of the tool. However, if the tool is used for different applications, with different accessories or is poorly maintained, the vibration and/or noise emission may differ. This may significantly increase the exposure level over the total working period. An estimation of the level of exposure to vibration and/or noise should also take into account the times when the tool is switched off or when it is running but not actually doing the job. This may significantly reduce the exposure level over the total working period.

Identify additional safety measures to protect the operator from the effects of vibration and/or noise such as: maintain the tool and the accessories, keep the hands warm (relevant for vibration), organisation of work patterns.

EC-Declaration of Conformity Machinery Directive and Radio Equipment Directive



DCW620 Plunge Router

DeWALT declares that these products described under **Technical Data** are in compliance with: 2006/42/EC, EN62841-1:2015 + AC:2015 + A11:2022; EN62841-2-17:2017.

These products also comply with Directive 2014/53/EU and 2011/65/EU. For more information, please contact DeWALT at the following address or refer to the back of the manual.

The undersigned is responsible for compilation of the technical file and makes this declaration on behalf of DeWALT.

Markus Rompel
Vice-President Engineering, PTE-Europe
DeWALT, Richard-Klinger-Strasse 11,
65510, Idstein, Germany

30.01.2024

DECLARATION OF CONFORMITY THE SUPPLY OF MACHINERY (SAFETY) REGULATIONS 2008 AND RADIO EQUIPMENT REGULATION 2017



DCW620 Plunge Router

DeWALT declares that these products described under "technical data" are in compliance with:

The Supply of Machinery (Safety) Regulations, 2008, S.I. 2008/1597 (as amended), EN62841-1:2015 + AC:2015 + A11:2022; EN62841-2-17:2017.

These products conform to the following UK Regulations
Radio Equipment Regulation, 2017, S.I.2017/1206 (as amended).

The Restriction of the Use of Certain Hazardous Substances in Electrical and Electronic Equipment Regulations 2012, S.I. 2012/3032 (as amended).

For more information, please contact DeWALT at the following address or refer to the back of the manual.

The undersigned is responsible for compilation of the technical file and makes this declaration on behalf of DeWALT.

Karl Evans
Vice President Professional Power Tools EANZ GTS

Batteries				Chargers/Charge Times (Minutes)***									
Cat #	V _{DC}	Ah	Weight (kg)	DCB104	DCB107	DCB112/ DCB1102	DCB113	DCB115/ DCB1104	DCB116	DCB117	DCB118	DCB132	DCB119
DCB546	18/54	6.0/2.0	1.08	60	270	170	140	90	80	40	60	90	X
DCB547/G	18/54	9.0/3.0	1.46	75*	420	270	220	135*	110*	60	75*	135*	X
DCB548	18/54	12.0/4.0	1.46	120	540	350	300	180	150	80	120	180	X
DCB181	18	1.5	0.35	22	70	45	35	22	22	22	22	22	45
DCB182	18	4.0	0.61	60/40**	185	120	100	60	60/45**	60/40**	60/40**	60	120
DCB183/B/G	18	2.0	0.40	30	90	60	50	30	30	30	30	30	60
DCB184/B/G	18	5.0	0.62	75/50**	240	150	120	75	75/60**	75/50**	75/50**	75	150
DCB185	18	1.3	0.35	22	60	40	30	22	22	22	22	22	40
DCB187	18	3.0	0.54	45	140	90	70	45	45	45	45	45	90
DCB189	18	4.0	0.54	60	185	120	100	60	60	60	60	60	120
DCBP034/G	18	1.7	0.32	27	82	50	40	27	27	27	27	27	50
DCBP518/G	18	5.0	0.75	50	240	150	120	75	60	50	50	75	150

*Date code 201811475B or later

**Date code 201536 or later

***Battery charge times matrix provided for guidance only; charge times will vary depending on temperature and condition of batteries.

DEWALT UK, Meadowfield Avenue,
Spennymoor, DL16 6YJ,
England
30.01.2024



WARNING: To reduce the risk of injury, read the instruction manual.

Definitions: Safety Guidelines

The definitions below describe the level of severity for each signal word. Please read the manual and pay attention to these symbols.

▲ DANGER: Indicates an imminently hazardous situation which, if not avoided, **will** result in **death or serious injury**.

▲ WARNING: Indicates a potentially hazardous situation which, if not avoided, **could** result in **death or serious injury**.

▲ CAUTION: Indicates a potentially hazardous situation which, if not avoided, **may** result in **minor or moderate injury**.

NOTICE: Indicates a practice **not related to personal injury** which, if not avoided, **may** result in **property damage**.

▲ Denotes risk of electric shock.

▲ Denotes risk of fire.

GENERAL POWER TOOL SAFETY WARNINGS

▲ WARNING: Read all safety warnings, instructions, illustrations and specifications provided with this power tool. Failure to follow all instructions listed below may result in electric shock, fire and/or serious injury.

SAVE ALL WARNINGS AND INSTRUCTIONS FOR FUTURE REFERENCE

The term "power tool" in the warnings refers to your mains-operated (corded) power tool or battery-operated (cordless) power tool.

1) Work Area Safety

a) **Keep work area clean and well lit.** Cluttered or dark areas invite accidents.

b) **Do not operate power tools in explosive atmospheres, such as in the presence of flammable liquids, gases or dust.** Power tools create sparks which may ignite the dust or fumes.

c) **Keep children and bystanders away while operating a power tool.** Distractions can cause you to lose control.

2) Electrical Safety

a) **Power tool plugs must match the outlet. Never modify the plug in any way. Do not use any adapter plugs with earthed (grounded) power tools.** Unmodified plugs and matching outlets will reduce risk of electric shock.

b) **Avoid body contact with earthed or grounded surfaces, such as pipes, radiators, ranges and refrigerators.** There is an increased risk of electric shock if your body is earthed or grounded.

c) **Do not expose power tools to rain or wet conditions.**

Water entering a power tool will increase the risk of electric shock.

d) **Do not abuse the cord. Never use the cord for carrying, pulling or unplugging the power tool. Keep cord away from heat, oil, sharp edges or moving parts.** Damaged or entangled cords increase the risk of electric shock.

e) **When operating a power tool outdoors, use an extension cord suitable for outdoor use.** Use of a cord suitable for outdoor use reduces the risk of electric shock.

f) **If operating a power tool in a damp location is unavoidable, use a residual current device (RCD) protected supply.** Use of an RCD reduces the risk of electric shock.

3) Personal Safety

a) **Stay alert, watch what you are doing and use common sense when operating a power tool. Do not use a power tool while you are tired or under the influence of drugs, alcohol or medication.** A moment of inattention while operating power tools may result in serious personal injury.

b) **Use personal protective equipment. Always wear eye protection.** Protective equipment such as a dust mask, non-skid safety shoes, hard hat or hearing protection used for appropriate conditions will reduce personal injuries.

c) **Prevent unintentional starting. Ensure the switch is in the off position before connecting to power source and/or battery pack, picking up or carrying the tool.** Carrying power

tools with your finger on the switch or energising power tools that have the switch on invites accidents.

d) **Remove any adjusting key or wrench before turning the power tool on.** A wrench or a key left attached to a rotating part of the power tool may result in personal injury.

e) **Do not overreach. Keep proper footing and balance at all times.** This enables better control of the power tool in unexpected situations.

f) **Dress properly. Do not wear loose clothing or jewellery. Keep your hair and clothing away from moving parts.** Loose clothes, jewellery or long hair can be caught in moving parts.

g) **If devices are provided for the connection of dust extraction and collection facilities, ensure these are connected and properly used.** Use of dust collection can reduce dust-related hazards.

h) **Do not let familiarity gained from frequent use of tools allow you to become complacent and ignore tool safety principles.** A careless action can cause severe injury within a fraction of a second.

4) Power Tool Use and Care

a) **Do not force the power tool. Use the correct power tool for your application.** The correct power tool will do the job better and safer at the rate for which it was designed.

b) **Do not use the power tool if the switch does not turn it on and off.** Any power tool that cannot be controlled with the switch is dangerous and must be repaired.

c) **Disconnect the plug from the power source and/or remove the battery pack, if detachable, from the power tool before making any adjustments, changing accessories, or storing power tools.** Such preventive safety measures reduce the risk of starting the power tool accidentally.

d) **Store idle power tools out of the reach of children and do not allow persons unfamiliar with the power tool or these instructions to operate the power tool.** Power tools are dangerous in the hands of untrained users.

e) **Maintain power tools and accessories. Check for misalignment or binding of moving parts, breakage of parts and any other condition that may affect the power tool's operation. If damaged, have the power tool repaired before use.** Many accidents are caused by poorly maintained power tools.

f) **Keep cutting tools sharp and clean.** Properly maintained cutting tools with sharp cutting edges are less likely to bind and are easier to control.

g) **Use the power tool, accessories and tool bits, etc. in accordance with these instructions, taking into account the working conditions and the work to be performed.** Use of the power tool for operations different from those intended could result in a hazardous situation.

h) **Keep handles and grasping surfaces dry, clean and free from oil and grease.** Slippery handles and grasping surfaces do not allow for safe handling and control of the tool in unexpected situations.

5) Battery Tool Use and Care

a) **Recharge only with the charger specified by the manufacturer.** A charger that is suitable for one type of battery pack may create a risk of fire when used with another battery pack.

b) **Use power tools only with specifically designated battery packs.** Use of any other battery packs may create a risk of injury and fire.

c) **When battery pack is not in use, keep it away from other metal objects, like paper clips, coins, keys, nails, screws or other small metal objects, that can make a connection from one terminal to another.** Shorting the battery terminals together may cause burns or a fire.

d) **Under abusive conditions, liquid may be ejected from the battery; avoid contact. If contact accidentally occurs, flush with water. If liquid contacts eyes, additionally seek medical help.** Liquid ejected from the battery may cause irritation or burns.

e) **Do not use a battery pack or tool that is damaged or modified.** Damaged or modified batteries may exhibit unpredictable behaviour resulting in fire, explosion or risk of injury.

f) **Do not expose a battery pack or tool to fire or excessive temperature.** Exposure to fire or temperature above 130 °C may cause explosion.

g) **Follow all charging instructions and do not charge the battery pack or tool outside the temperature range specified in the instructions.** Charging improperly or at temperatures outside the specified range may damage the battery and increase the risk of fire.

6) Service

a) **Have your power tool serviced by a qualified repair person using only identical replacement parts.** This will ensure that the safety of the power tool is maintained.

b) **Never service damaged battery packs.** Service of battery packs should only be performed by the manufacturer or authorised service providers.

Safety Instructions for Routers

a) **Use clamps or another practical way to secure and support the workpiece to a stable platform.** Holding the work by your hand or against the body leaves it unstable and may lead to loss of control.

b) **Keep handles dry, clean and free from oil and grease.** This will enable better control of the tool.

c) **Maintain a firm grip with both hands on the tool to resist starting torque.** Maintain a firm grip on the tool at all times while operating.

d) **Keep hands away from cutting area above and below the base. Never reach under the workpiece for any reason.** Keep the router base firmly in contact with the workpiece when cutting.

e) **Never touch the bit immediately after use.** Danger of burning bit may extremely hot.

f) **Be sure that the motor has stopped completely before you lay the router down.** If the bit is still spinning when the tool is laid down, it could cause injury or damage.

g) **Be sure that the router bit is clear of the workpiece before starting the motor.** If the bit is in contact with the workpiece when the motor starts, it could make the router jump, causing damage or injury.

h) **The permitted speed of the cutting bit must be at least equal to the maximum speed marked on the power tool.** If cutting bits run faster than their rated speed, they may break and fly off.

i) **Always follow the bit manufacturer's speed recommendations as some bit designs require specific speeds for safety or performance.** If you are unsure of the proper speed or are experiencing any type of problem, contact the bit manufacturer.

j) **Do not use router bits with a diameter in excess of 63 mm (2-1/2") in this tool.**

k) **Keep cutting pressure constant.** Too high of a pressure can overload the motor or damage the workpiece.

l) **Provide clearance under workpiece for bit when through-cutting.** There is a risk of cutting into objects below the workpiece.

m) **Do not press spindle lock button while the motor is running.** Doing so can damage the spindle lock.

n) **Always make sure the work surface is free from nails and other foreign objects.** Cutting into a nail can cause the bit and the tool to jump.

o) **Before starting the motor, clear the work area of all foreign objects.**

p) **Keep handles and gripping surfaces dry, clean, and free from oil and grease.** This will enable better control of the tool.

q) **Use sharp bits.** Dull bits may cause the router to swerve or stall under pressure.

r) **Do not use blunt or damaged cutting bits.** Blunt or damaged cutting bits cause increased friction, create imbalances and may become jammed.

s) **DO NOT CUT METAL.**

Residual Risks

In spite of the application of the relevant safety regulations and the implementation of safety devices, certain residual risks cannot be avoided. These are:

- Impairment of hearing.
- Risk of personal injury due to flying particles.
- Risk of burns due to accessories becoming hot during operation.
- Risk of personal injury due to prolonged use.

SAVE THESE INSTRUCTIONS

Battery Type

These battery packs may be used: DCB181, DCB182, DCB183, DCB183B, DCB183G, DCB184, DCB184B, DCB184G, DCB185, DCB187, DCB189, DCBP034, DCBP034G, DCBP518, DCBP518G, DCB546, DCB547, DCB547G, DCB548. Refer to **Technical Data** for more information.

Package Contents

- 1 Plunge router
- 1 Airlock vac adaptor
- 1 Dust port cover
- 1 Side fence
- 1 Collet 8 mm
- 1 Collet 12 mm
- 1 Guide bushing
- 1 Subbase adaptor
- 1 Chip collector
- 1 Wrench 22 mm
- 1 Centering cone
- 1 Dust cap
- 1 Large dust cap 50 mm

- 1 Li-Ion battery pack (C1, D1, E1, G1, H1, L1, M1, P1, Q1, S1, T1, U1, X1, Y1, Z1 models)
- 2 Li-Ion battery packs (C2, D2, E2, G2, H2, L2, M2, P2, Q2, S2, T2, U2, X2, Y2, Z2 models)
- 3 Li-Ion battery packs (C3, D3, E3, G3, H3, L3, M3, P3, Q3, S3, T3, U3, X3, Y3, Z3 models)
- 1 Instruction manual

NOTE: Battery packs, chargers and kitboxes are not included with N models. Battery packs and chargers are not included with NT models. B models include Bluetooth® battery packs.

NOTE: The Bluetooth® word mark and logos are registered trademarks owned by the Bluetooth®, SIG, Inc. and any use of such marks by DEWALT is under license. Other trademarks and trade names are those of their respective owners.

- Check for damage to the tool, parts or accessories which may have occurred during transport.
- Take the time to thoroughly read and understand this manual prior to operation.

Markings on Tool

The following pictograms are shown on the tool:



Read instruction manual before use.



Wear ear protection.



Wear eye protection.



Visible radiation. Do not stare into light.

Date Code Position (Fig. B)

The production date code **48** consists of a 4-digit year followed by a 2-digit week and is extended by a 2-digit factory code.

Description (Fig. A)

▲ WARNING: Never modify the power tool or any part of it. Damage or personal injury could result.

- 1 Battery pack
- 2 Battery pack release button
- 3 On/off trigger switch
- 4 Variable speed dial
- 5 Main handles
- 6 Plunge lock lever
- 7 Plunge release lever
- 8 Dust cap
- 9 Dust column
- 10 Base plate
- 11 Spindle lock button
- 12 Collet
- 13 Multiple position turret stop
- 14 Depth stop bar/rod
- 15 22 mm wrench
- 16 Depth indicator
- 17 Micro height adjustment
- 18 Lock-on button switch

Intended Use

This router has been designed for professional heavy duty routing of wood, wood based materials, composite laminate, and plastics.

This router is intended for routing grooves, edges, profiles and slots as well as copy routing.

DO NOT use under wet conditions or in the presence of flammable liquids or gases.

This is a professional power tool.

DO NOT let children come into contact with the tool.

Supervision is required when inexperienced operators use this tool.

- **Young children and the infirm.** This appliance is not intended for use by young children or infirm persons without supervision.
- This product is not intended for use by persons (including children) suffering from diminished physical, sensory or mental abilities; lack of experience, knowledge or skills unless they are supervised by a person responsible for their safety. Children should never be left alone with this product.

ASSEMBLY AND ADJUSTMENTS

▲ WARNING: To reduce the risk of serious personal injury, turn tool off and disconnect battery pack before making any adjustments or removing/installing attachments or accessories. An accidental start-up can cause injury.

▲ WARNING: Use only DEWALT batteries and chargers.

▲ Plunge Lock Lever (Fig. C)

The plunge lock lever **6** allows you to stop the routing bit at a specified height.

1. Unlock the plunge mechanism by pushing down on the plunge release lever **7** (refer to Fig. C).
2. To keep the plunge release lever open push the lever down until it clicks and stays in position.
3. You can lower the unit up or down.
4. To lock the plunge depth of the tool, push the plunge lock lever **6**.

Collets (Fig. D)

▲ WARNING: Projectile hazard. Only use bits with shanks that match the installed collet. Smaller shank bits will not be secure and could become loose during operation.

▲ CAUTION: Never tighten the collet without first installing a router bit in it. Tightening an empty collet, even by hand, can damage the collet.

Two collets **12** are included with the router.

- 8 mm
- 12 mm

Installing/Removing Collets

1. To install a collet **12**, press the spindle lock button **11** to lock the spindle **35**.
2. Attach the collet to the spindle and hand-tighten the collet by rotating it clockwise.
3. To remove the collet, press the spindle lock button and loosen the collet by rotating counterclockwise.

NOTE: Using a wrench to fully tighten or loosen the collet will only be needed when installing or removing a bit. Refer to section **Installing and Removing a Bit**.

Installing and Removing a Bit (Fig. A, E)

▲ WARNING: Do not tighten the collet without a bit fitted.

▲ WARNING: Always use bits with shanks which match the diameter of the collet.

▲ WARNING: Do not use bits larger than 63 mm (2-1/2").

▲ CAUTION: Care should be taken when removing bit to avoid cuts to fingers. Wearing protective gloves while fitting and changing router bits is recommended.

Installing a Bit

1. Insert at least three-fourths of the shank length of the bit into the collet **12**.
2. Press the spindle lock button **11** to lock the spindle **35**.
NOTE: You may need to turn the spindle slightly to engage it.
3. Turn the collet counterclockwise with the supplied 22 mm wrench **15** to tighten it.
4. Tighten collet nut securely to prevent the bit from slipping.

Removing a Bit

1. Press the spindle lock button **11** to lock the spindle **35**.
2. Turn the collet **12** clockwise with the supplied 22 mm wrench **15** to loosen.
3. Keep turning the wrench until the collet tightens and then loosens again. This is the fail-safe mechanism releasing the collet.
4. The bit should now slide out.

NOTE: Each time you finish using a bit, remove it and store it in a safe place.

Multiple Position Turret Stop (Fig. F)

▲ WARNING: Do not change the multiple position turret stop while the router is running. This will place your hands too near the bit head.

The multiple position turret stop **13** limits the downward distance that the tool can be plunged. It consists of three screws of different lengths that serve to define the depth of cut by limiting the travel of the depth stop bar/rod **14**.

1. Routing depth can be set by selecting the screw of the appropriate length on the turret.
2. The turret is rotatable with detent stops to properly align the screws.
3. It is the interaction of the depth stop bar/rod and the multiple position turret stop that determine the routing depth.
4. If none of the provided screws seems close to the desired height each can be adjusted by loosening the hex nut at the bottom and then turning the screw either in or out to make it the proper length. After adjusting this screw be sure to tighten the hex nut at the bottom with an 8 mm wrench **19**.
5. Refer to section **Adjusting the Plunge Routing Depth** for instructions on how to use the multiple position turret stop in an actual operation.

Adjusting the Plunge Routing Depth (Fig. A, C, F, P)

▲ WARNING: Laceration hazard. Do not change the multiple position turret stop while the router is running. This will place your hands too near the bit head.

▲ WARNING: To prevent loss of control, ALWAYS tighten the travel-limiting nuts together. Inadvertent movement could prevent full bit retraction.

▲ WARNING: To prevent loss of control, set the travel-limiting nuts so that bit can be retracted into the base of the router, clear of the workpiece.

▲ WARNING: To reduce the risk of injury, NEVER adjust or remove the stop nut. Motor can disengage resulting in loss of control.

▲ CAUTION: Turn the router on before plunging the bit head into the workpiece.

1. Unlock the plunge mechanism by pushing down the plunge release lever **7**. Gently push down on the two main handles **5** to plunge the router down as far as it will go, allowing the bit to just touch the workpiece.
2. Lock the plunge mechanism by pushing the plunge lock lever **6**.
3. Loosen the depth stop bar/rod **14** by pulling up on the depth stop lock lever **21**.
4. Slide the depth stop bar/rod down so that it meets the lowest multiple position turret stop **13**.
5. Slide the depth indicator **16** on the depth stop bar/rod down so that the top of it meets zero on the depth adjustment scale **22**.
6. Grasping the top, knurled section of the depth stop bar/rod, slide it up so that the depth indicator aligns with the desired depth of cut on the depth adjustment scale.
7. Push down on the depth stop lock lever to hold the depth stop bar/rod in place.
8. Keeping both hands on the handles, unlock the plunge mechanism by pushing down the plunge release lever. The plunge mechanism and the motor will move up. When the router is plunged, the depth stop bar/rod will hit the multiple position turret stop, allowing the router to reach exactly the desired depth.

Fitting the Side Fence (Fig. H, I)

1. Fit the guide rods **26** to the base plate **10**.
2. Slide the side fence **27** over the guide rods.
3. Tighten the wing bolts **28** temporarily.

Adjusting the Side Fence (Fig. A, H, I)

1. Draw a cutting line on the material.
2. Lower the router carriage until the bit is in contact with the workpiece.
3. Push plunge lock lever **6** and limit the carriage return.
4. Position the router on the cutting line.
5. Slide the side fence **27** against the workpiece and tighten the wing bolts **28**.
6. Adjust the side fence using the adjustment knob **29**. The outer cutting edge of the bit must coincide with the cutting line.
7. If required, loosen the screws **30** and adjust the strips **31** to obtain the desired guiding length.

Fitting a Guide Bushing (Fig. A, G)

Together with a template, the guide bushings play a valuable part in cutting and shaping to a pattern. For using a guide bushing with this tool please choose the subbase adaptor **47**.

1. Attach the guide bushing **24** to the subbase adaptor **47** using the screws **25** as shown.
2. Center the guide bushing to the collet **12** by using the centering cone and tighten the subbase screws. Refer to section **Centering the Subbase**.



Dust Extraction

Dust from materials such as lead-containing coatings and some wood types can be harmful to one's health. Breathing in the dust can cause allergic reactions and/or lead to respiratory infections of the user or bystanders.

Certain dust, such as oak or beech dust, is considered carcinogenic, especially in connection with wood-treatment additives.

Observe the relevant regulations in your country for the materials to be worked.

The vacuum cleaner must be suitable for the material being worked.

When vacuuming dry dust that is especially detrimental to health or carcinogenic, use dust class M vacuum cleaner.

Connecting Dust Extractor Hose (Fig. 01, 02)

▲ WARNING: Risk of dust inhalation. To reduce the risk of personal injury, ALWAYS wear an approved dust mask.

▲ WARNING: ALWAYS use a vacuum extractor designed in compliance with the applicable directives regarding dust emission when routing wood.

▲ CAUTION: Do not operate the router without the dust cap if the router is not connected to a dust extraction system.

A dust extraction tube adaptor **34** is supplied with your tool. Vacuum hoses on most vacuum extractors will fit directly onto the dust column **9**.

1. Insert the dust extraction tube adaptor **34** into the top of the dust column **9** (Fig. 01).
2. Connect a dust extractor hose **43** to the extraction tube adaptor **34** using the DeWALT quick lock system.

A dust cover **45** is supplied for use with your tool when a dust extraction system is not in use.

3. Cover the dust column **9** with the dust cover **45** to seal up the tool (Fig. 02).

NOTE: When using dust extraction, be sure that the vacuum cleaner is out of the way and secure so that it will not tip over or interfere with the router or workpiece. The vacuum hose and power cord must also be positioned so that they do not interfere with the router or workpiece. If the vacuum cleaner or vacuum hose cannot be positioned properly, it should be removed.

OPERATION

▲ WARNING: To reduce the risk of serious personal injury, turn tool off and disconnect battery pack before making any adjustments or removing/installing attachments or accessories. An accidental start-up can cause injury.

▲ CAUTION: Before connecting tool to power source, check to see that the switch is in the "OFF" position. An accidental start-up can cause injury.

Proper Hand Position (Fig. A, M)

▲ WARNING: To reduce the risk of serious personal injury, ALWAYS use proper hand position as shown.

▲ WARNING: To reduce the risk of serious personal injury, ALWAYS hold securely in anticipation of a sudden reaction. Proper hand position requires both hands on the main handles **5**.

Wireless Tool Control (Fig. A)

▲ CAUTION: Read all safety warnings, instructions and specifications of the appliance which is paired with the tool. Your tool is equipped with a Wireless Tool Control™ transmitter which allows your tool to be wirelessly paired with another Wireless Tool Control™ device, such as a dust extractor.

To pair your tool using Wireless Tool Control™, press and hold the Wireless Tool Control™ pairing button on your pairing device and squeeze the on/off trigger switch **3**. An LED on the separate device will let you know when your tool has been successfully paired.

Installing and Removing the Battery Pack (Fig. B)

▲ CAUTION: Before inserting the battery, check to see that the switch is in the OFF position. An accidental start-up can cause injury.

NOTE: For best results, make sure your battery pack is fully charged.

To Install the Battery Pack into the Tool

1. Align the battery pack **1** with the rails on top of tool (Fig. B).
2. Slide it into the rails until the battery pack is firmly seated in the tool and ensure that you hear the lock snap into place.

To Remove the Battery Pack from the Tool

1. Press the battery release button **2** and firmly pull the battery pack out of the tool.
2. Insert battery pack into the charger.

Fuel Gauge Battery Packs (Fig. B)

Some DEWALT battery packs include a fuel gauge, which consists of three green LED lights that indicate the level of charge remaining in the battery pack.

To actuate the fuel gauge, press and hold the fuel gauge button **20**. A combination of the three green LED lights will illuminate, designating the level of charge left. When the level of charge in the battery is below the usable limit, the fuel gauge will not illuminate and the battery will need to be recharged.

NOTE: The fuel gauge is only an indication of the charge left on the battery pack. It does not indicate tool functionality and is subject to variation based on product components, temperature and end-user application.

On/Off Trigger Switch (Fig. A)

▲ WARNING: To reduce the risk of serious personal injury, turn unit off and remove the battery pack before making any adjustments or removing/installing attachments or accessories. An accidental start-up can cause injury.

▲ WARNING: Be sure that the bit is clear of the workpiece before starting the motor. If the bit is in contact with the workpiece when the motor starts, it could make the router jump, causing damage or injury.

1. To turn the unit on, flip the lock-off lever **46** down towards the bottom of the main handle **5**, then squeeze the on/off trigger switch **3**. Continue to squeeze the on/off trigger switch or press the lock-on button switch **18** for continuous running.
2. To turn the unit off:
 - a. If the lock-on button switch is engaged, release the lock-on button switch by squeezing and releasing the on/off trigger switch.
 - b. If the lock-on button switch is not engaged, fully release the on/off trigger switch.

NOTE: Be sure that the motor has stopped completely before laying the router down. If the bit is still spinning when the tool is laid down it could cause injury or damage.

Choosing Router Speed (Fig. A)

Refer to the **Speed Selection Chart** to choose a router speed. Turn the variable speed dial **4** to control router speed.

Soft Start Feature

This plunge base router is equipped with electronics to provide a soft start feature that minimizes the start-up torque of the motor.

Variable Speed Dial (Fig. A)

▲ WARNING: If the variable speed dial ceases to operate, or is intermittent, stop using the tool immediately. Take it to a DEWALT factory service center or a DEWALT authorized service center for repair.

▲ WARNING: Always follow the bit manufacturer's speed recommendations as some bit designs require specific speeds for safety or performance. If you are unsure of the proper speed or are experiencing any type of problem, contact the bit manufacturer.

This router is equipped with a variable speed dial **4** with 7 speeds between 11000 and 23000 RPM. Adjust the speed by turning the variable speed dial.

NOTICE: The router is equipped with electronics to monitor and maintain the speed of the tool while cutting. In low and medium speed operation, the variable speed dial prevents the motor speed from decreasing. If you expect to hear a speed change and continue to load the motor, you could damage the motor by overheating. Reduce the depth of cut and/or slow the feed rate to prevent tool damage.

SPEED SELECTION CHART*

DIAL SETTING	APPROX. RPM
1	11000
2	13000
3	15000
4	17000
5	19000
6	21000
7	23000

*The speeds in this chart are approximate and are for reference only. Your router may not exactly produce the speed listed for the dial setting.

NOTE: Make several light passes instead of one heavy pass for better quality work.

Using the Router (Fig. A, J, M)

▲ CAUTION: Turn the router on before plunging the bit into the workpiece.

CAUTION:

- Excessive cutting may cause overload of the motor or difficulty in controlling the tool. The depth of cut should not be more than 15 mm (19/32") at a pass when cutting grooves with an 8 mm (5/16") diameter bit.

- When cutting grooves with a 20 mm (25/32") diameter bit, the depth of cut should not be more than 5 mm (3/16") at a pass.
- For extra deep grooving, make two or three passes with progressively deeper bit settings.

CAUTION:

- After long periods of working at low speeds, allow the machine to cool down by running it for three minutes at maximum speed, with no load.

All common routing tasks can be performed with the plunge cut router on all types of wood and plastic:

- Grooving
- Rabbeting
- Recessing
- Veining
- Profiling

NOTE: Only carbide-tipped bits should be used on panels faced with plastic laminates. The hard laminates will quickly dull steel bits.

NOTE: For better plunge sliding movement, frequently clean the plunge rods **36** of dust or debris with a DRY cloth only. If the plunging movement is not moving as smoothly as desired, lubricate the plunge rods with a dry Teflon™ lubricant.

1. After setting the cutting depth as described, locate the router such that the bit is directly over the place you will be cutting.
2. With the router running, lower the unit smoothly down into the workpiece. **DO NOT JAM THE ROUTER DOWN.**
3. When the tool reaches the pre-set depth, push the plunge lock lever **6** to lock.
4. When you have finished routing, push down on the plunge release lever **7** to unlock and let the spring lift the router directly out of the workpiece.
5. Always feed the router opposite to the direction in which the bit is rotating. Refer to Fig. J.

Moulding Natural Timbers

▲ WARNING: When routing always lock the plunge locking lever.

When edge moulding natural timbers, always mould the end grain first, followed by the long grain. This ensures that if there is breakout, it will be removed when the long grain is routed.

Worklight LEDs (Fig. A, S)

▲ CAUTION: Do not stare into worklight. Serious eye injury could result.

Two worklight LEDs **44** are located next to the collet **12**.

1. To turn on the worklight, switch on the on/off trigger switch **3**. Worklights will remain on for 20 seconds after the on/off switch is moved to the off position.

NOTE: The worklight is for lighting the immediate work surface and is not intended to be used as a flashlight.

NOTE: If worklights flash, check the charge on the battery; it could be low. If they still flash with a charged battery, the unit should be taken to a service center for evaluation.

Direction Of Feed (Fig. J)

▲ WARNING: Avoid climb-cutting (cutting in direction opposite than shown in Fig. J). Climb-cutting increases the chance for loss of control resulting in possible injury. When climb-cutting is required (backing around a corner), exercise extreme caution to maintain

control of router. Make smaller cuts and remove minimal material with each pass.

The direction of feed is very important when routing and can make the difference between a successful job and a ruined project. The figures show the proper direction of feed for some typical cuts. A general rule to follow is to move the router in a counterclockwise direction on an outside cut and a clockwise direction on an inside cut.

Shape the outside edge of a piece of stock by following these steps:

1. Shape the end grain, left to right.
2. Shape the straight grain side moving left to right.
3. Cut the other end grain side.
4. Finish the remaining straight grain edge.

Feed Load**Heavy Load Indicator LED (Fig. N)**

Your tool is equipped with a heavy load indicator LED **39**. If the heavy load indicator LED white triangle is flashing, slow down the speed of the tool.

The speed at which the bit is fed into the wood must not be too fast that the motor slows down, or too slow that the bit leaves burn marks on the face of the wood.

NOTE: Practice judging the speed by listening to the sound of the motor when routing.

Anti-Rotation System (Fig. N)

Your tool is equipped with the DEWALT anti-rotation system.

This feature senses the motion of the tool and shuts the tool down if necessary. The red LED indicator **40** illuminates when the anti-rotation system is engaged.

INDICATOR	DIAGNOSIS	SOLUTION
OFF	Tool is functioning normally	Follow all warnings and instructions when operating the tool.
SOLID RED	Anti-Rotation System has been activated (ENGAGED)	With the tool properly supported, release trigger. The tool will function normally when the trigger is depressed again and the indicator light will go out.

Sequence of Plunging (Fig. A)

▲ WARNING: When routing always lock the plunge locking lever.

1. Plunge down and lock the motor carriage by pushing the plunge lock lever **6**.
2. Perform the desired routing operation.
3. Push down the plunge release lever **7** and the motor carriage returns to the normal position.

Side Fence Routing (Fig. H)

The side fence is used to guide the router when moulding, edge profiling or rebating the edge of a workpiece or when routing grooves and slots in the center of the workpiece, parallel to the edge.

The edge of the workpiece must be straight and true.

The strips **31** are adjustable and should be set ideally with a 3 mm (1/8") gap on each side of the bit.

Using a Side Fence (Fig. A, I)

▲ CAUTION: Ensure working position is comfortable and at a suitable working height.

1. Ensure the wing bolts **28** are fully released. Slide the guide rods **26** into the base plate **10** and tighten the wing bolts.
 2. Adjust the adjustment knob **29** to the required distance and clamp in place with the wing bolts.
 3. Then lower the bit height until the bit is just above the workpiece.
 4. Fine adjustments are possible by loosening the wing bolt and adjusting the side fence adjustment knob.
 5. Tighten the wing bolt to secure the position.
- NOTE:** One revolution of the adjustment knob equals 1 mm (3/64") of side feed.

6. Lower the bit onto the workpiece and set the bit height to the required distance. Refer to **Adjusting the Plunge Routing Depth**.

7. Switch the router on and after the bit reaches full speed, gently lower the bit into the workpiece and lock the plunge.
8. Feed along the workpiece, keeping sideways pressure to ensure the side fence does not wander away from the workpiece edge and downward pressure on the inside hand to prevent the router from tipping.
9. When finished, raise the router, secure with the plunge lock lever **6** and switch the router off.

NOTE: When starting the cut, keep the pressure on the front cheek until the back cheek contacts the workpiece edge.

NOTE: At the end of the cut, keep pressure on the back cheek until the cut is finished. This will prevent the router bit swinging in at the end of the workpiece and nipping the corner.

Centering the Subbase (Fig. A, K)

If you need to adjust, change, or replace the subbase, a centering tool is recommended (refer to **Optional Accessories**). The centering tool consists of a centering cone.

To adjust the subbase, follow the steps below.

1. Loosen but do not remove the subbase screws **32** so the subbase moves freely.
2. Insert the centering cone **42** through the hole of the subbase into the collet **12** and tighten the collet. This will center the subbase.
3. With the centering cone in place, tighten the subbase screws.

NOTE: The adaptor subbase should be centered without the guide bushing attached. Refer to the section **Fitting a Guide Bushing**.

Fine Adjustment of Routing Depth (Fig. P)

The micro height adjustment **17** at the bottom end of the depth stop bar/rod **14** can be used to make minor adjustments.

1. To decrease the cutting depth, rotate the micro height adjustment clockwise (looking down from the top of the router).
2. To increase the cutting depth, rotate the micro height adjustment counterclockwise (looking down from the top of the router).

NOTE: One complete rotation of the micro height adjustment results in a change of about 1 mm (0.04") in depth.

Using the Rotating Turret for Stepped Cuts (Fig. F)

If the depth of cut required is more than is acceptable in a single pass, rotate the multiple position turret stop **13** so that the depth stop bar/rod **14** lines up with taller multiple position turret stop initially. After each cut, rotate the multiple position turret stop so that the depth stop lines up with shorter post until the final depth of cut is reached. Refer to the section **Multiple Position Turret Stop**.

▲ WARNING: Do not change the multiple position turret stop while the router is running. This will place your hands too near the bit.

Cutting with the Plunge Base (Fig. A, C, M)

NOTE: The depth of cut is locked in the plunge base's default state. The plunge lock requires user actuation to enable the "release to lock" plunge mechanism.

NOTE: Grip both main handles **5** while operating.

1. Turn the router on before plunging the bit into the workpiece.
2. Push down the plunge release lever **7** and plunge the router down until the bit reaches the set depth.
3. Push the plunge lock lever **6** when desired depth is reached.

NOTE: Pushing the plunge lock lever automatically locks the motor in place.

NOTE: If additional resistance is needed, use the hand to push the plunge lock lever.

4. Perform the cut.
5. Pushing down the plunge release lever will disable the locking mechanism allowing the router bit to disengage from the workpiece.
6. Turn the router off.

Dust Cap (Fig. R1–R3)

A dust cap **8** comes provided with your router designed to reduce airborne dust by directing dust and debris away from the user.

To attach:

1. Sit the router upright with the base plate **10** resting on a flat surface.
2. Place the dust cap **8** through the opening of the base plate lining up the dust cap hinges **37** with the base plate hinge openings **41**.
3. Rotate the dust cap down flush with the base plate until the dust cap tab **23** clicks, locking it into place (Fig. R1).

To remove:

4. Push on the dust cap tab **23** to unlock (Fig. R2).
5. Rotate up toward the hinges and remove dust cap from the base plate opening.

NOTE: Always keep the dust cap clean and in place.

NOTE: This tool comes with an optional larger dust cap (50 mm) (Fig. R3).

Chip Collector Adaptor for Dust Extraction (Fig. Q1, Q2)

Your tool comes with a chip collector adaptor for edge-cutting, designed to effectively divert dust and chips to the vacuum.

To attach:

1. Slide the chip collector **33** into the underside of the base plate **10** until you hear a click (Fig. Q1).

To remove:

2. Squeeze both sides of the chip collector adaptor while sliding away from the base plate and then pulling down (Fig.Q2).

MAINTENANCE

Your power tool has been designed to operate over a long period of time with a minimum of maintenance. Continuous satisfactory operation depends upon proper tool care and regular cleaning.

▲ WARNING: To reduce the risk of serious personal injury, turn tool off and disconnect battery pack before making any adjustments or removing/installing attachments or accessories. An accidental start-up can cause injury. The charger and battery pack are not serviceable.

Lubrication

Your power tool requires no additional lubrication.

Cleaning (Fig. M)

▲ WARNING: Electrical shock and mechanical hazard. Disconnect the electrical appliance from the power source before cleaning.

▲ WARNING: To ensure safe and efficient operation, always keep the electrical appliance and the ventilation slots clean.

▲ WARNING: Never use solvents or other harsh chemicals for cleaning the non-metallic parts of the tool. These chemicals may weaken the materials used in these parts. Use a cloth dampened only with water and mild soap. Never let any liquid get inside the tool; never immerse any part of the tool into a liquid.

For better plunge sliding movement, frequently clean the plunge rods **36** of dust or debris with a DRY cloth only. If the plunging movement is not moving as smoothly as desired, lubricate the plunge rods with a dry Teflon™ lubricant.

Ventilation slots can be cleaned using a dry, soft non-metallic brush and/or a suitable vacuum cleaner. Do not use water or any cleaning solutions. Wear approved eye protection and an approved dust mask.

Optional Accessories

▲ WARNING: Since accessories, other than those offered by DEWALT, have not been tested with this product, use of such accessories with this tool could be hazardous. To reduce the risk of injury, only DEWALT-recommended accessories should be used with this product.

Consult your dealer for further information on the appropriate accessories.

Base Mounting Points for Accessories (Fig. L)

This router has three threaded holes **38** built into the base that allow it to attach to other accessories.

Protecting the Environment



Separate collection. Products and batteries marked with this symbol must not be disposed of with normal household waste.

■ Products and batteries contain materials that can be recovered or recycled, reducing the demand for raw materials. Please recycle electrical products and batteries according to local provisions. Further information is available at www.2helpU.com.

Rechargeable Battery Pack

This long-life battery pack must be recharged when it fails to produce sufficient power on jobs that were easily done before. At the end of its technical life, discard it with due care for our environment:

- Run the battery pack down completely, then remove it from the tool.
- Li-Ion cells are recyclable. Take them to your dealer or a local recycling station. The collected battery packs will be recycled or disposed of properly.