



ART. 3017

Fascette stringitubo DIN 3017 W4 - h. 9 mm , aisi 304 / A2

Hose clamps DIN 3017 W4 - h. 9 mm, aisi 304 / A2



Codice Articolo Item Number	Ø (mm)	 Box	 Master carton	 Pallet
30170801603	08 - 16	100	800	28800
30171202003	12 - 20	100	800	28800
30171202203	12 - 22	100	800	28800
30171602503	16 - 25	50	400	14400
30172003203	20 - 32	50	250	9000
30172504003	25 - 40	50	200	7200
30173205003	32 - 50	50	150	5400
30174006003	40 - 60	25	100	3600
30175007003	50 - 70	25	100	3600

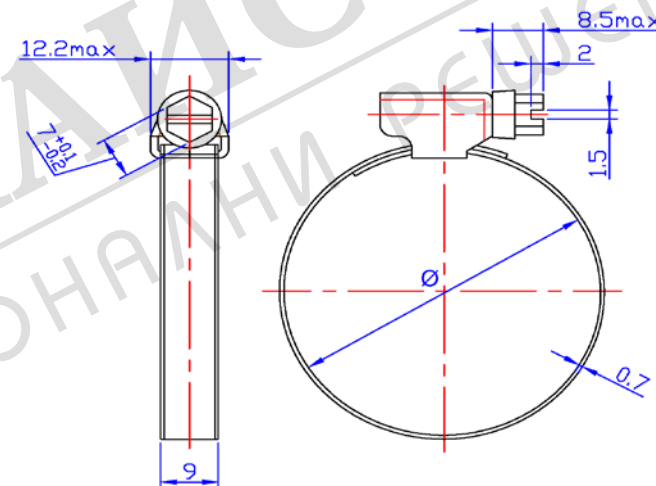

Banda con bordo rialzato e superficie interna piana, per evitare danneggiamenti al tubo.

Viti in acciaio inossidabile, sottoposte ad un ulteriore trattamento di zincatura (CR+3), per evitare il fenomeno del "Grippaggio"

With edge raised band and plani inner surface to avoid damages at the hose.

Stainless Steel screws, submitted to a further galvanizing treatment (zinc plated CR+3) in order to avoid "Seizing"

last edit 19/02/2019

DRAWING N. 1021

ART. 3017

Fascette stringitubo DIN 3017 W4 - h. 12 mm , aisi 304 / A2

Hose clamps DIN 3017 W4 h. 12 mm, aisi 304 / A2



Codice Articolo Item Number	∅ (mm)	Box	Master carton	Pallet
30171602502	16 - 25	50	400	14400
30172003202	20 - 32	50	250	9000
30172504002	25 - 40	50	150	5400
30173205002	32 - 50	50	150	5400
30174006002	40 - 60	25	100	3600
30175007002	50 - 70	25	75	2700
30176008002	60 - 80	25	75	2700
30177009002	70 - 90	25	75	2700
30178010002	80 - 100	25	50	1800
30179912002	100 - 120	10	30	1080
30179914002	120 - 140	10	20	720
30179915002	130 - 150	10	30	1080
30179916002	140 - 160	10	30	1080

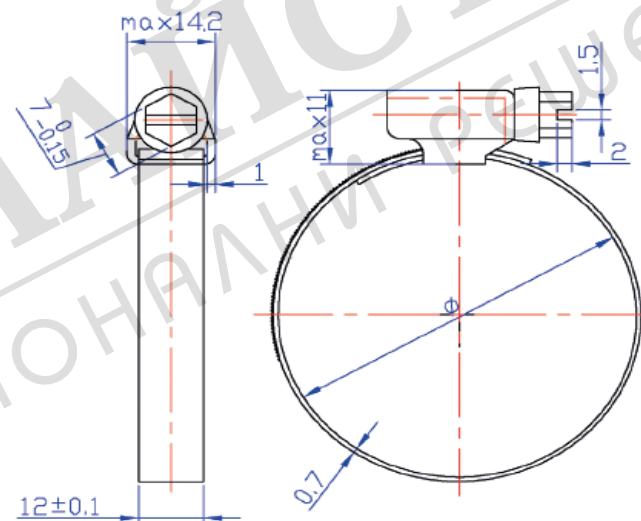

Banda con bordo rialzato e superficie interna piana, per evitare danneggiamenti al tubo.

Viti in acciaio inossidabile, sottoposte ad un ulteriore trattamento di zincatura (CR+3), per evitare il fenomeno del "Grippaggio"

With edge raised band and plani inner surface to avoid damages at the hose.

Stainless Steel screws, submitted to a further galvanizing treatment (zinc plated CR+3) in order to avoid "Seizing"

last edit 19/02/2019

DRAWING N. 1021

ART. 3017

Fascette stringitubo DIN 3017 W5 - h. 9 mm , aisi 316 / A4

Hose clamps DIN 3017 W5 - h. 9 mm, aisi 316 / A4



Codice Articolo Item Number	Ø (mm)	Box	Master carton	Pallet
30170801605	08 - 16	100	800	28800
30171202005	12 - 20	100	500	18000
30171602505	16 - 25	50	400	14400
30172003205	20 - 32	50	250	9000
30172504005	25 - 40	50	200	7200
30173205005	32 - 50	50	150	5400
30174006005	40 - 60	25	100	3600

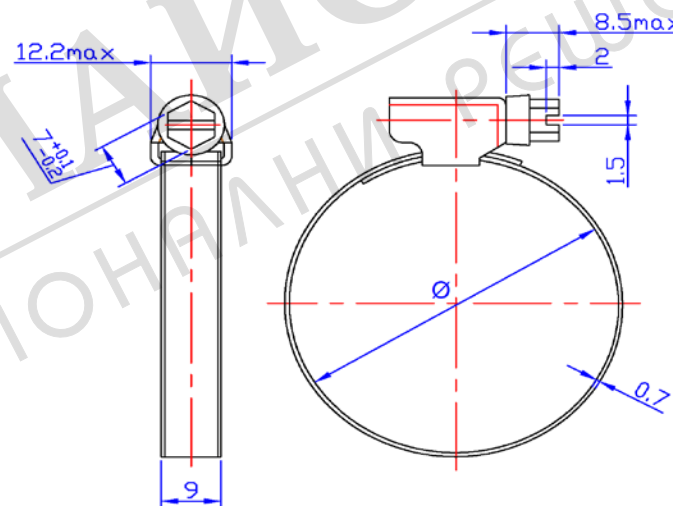

Banda con bordo rialzato e superficie interna piana, per evitare danneggiamenti al tubo.

Viti in acciaio inossidabile, sottoposte ad un ulteriore trattamento di zincatura (CR+3), per evitare il fenomeno del "Grippaggio"

With edge raised band and plani inner surface to avoid damages at the hose.

Stainless Steel screws, submitted to a further galvanizing treatment (zinc plated CR+3) in order to avoid "Seizing"

last edit 19/02/2019



DRAWING N. 1021

ART. 3017

Fascette stringitubo DIN 3017 W5 - h. 12 mm , aisi 316 / A4

Hose clamps DIN 3017 W5 - h. 12 mm, aisi 316 / A4



Codice Articolo Item Number	Ø (mm)	 Box	 Master carton	 Pallet
30171602504	16 - 25	50	300	10800
30172003204	20 - 32	50	250	9000
30172504004	25 - 40	50	150	5400
30173205004	32 - 50	50	150	5400
30174006004	40 - 60	25	125	4500
30175007004	50 - 70	25	75	2700
30176008004	60 - 80	25	75	2700
30177009004	70 - 90	25	75	2700
30178010004	80 - 100	25	50	1800
30179011004	90 - 100	25	50	1800
30179912004	100 - 120	10	30	1080
30179913004	100 - 130	10	30	1080
30179914004	120 - 140	10	20	720
30179916004	140 - 160	10	30	1080

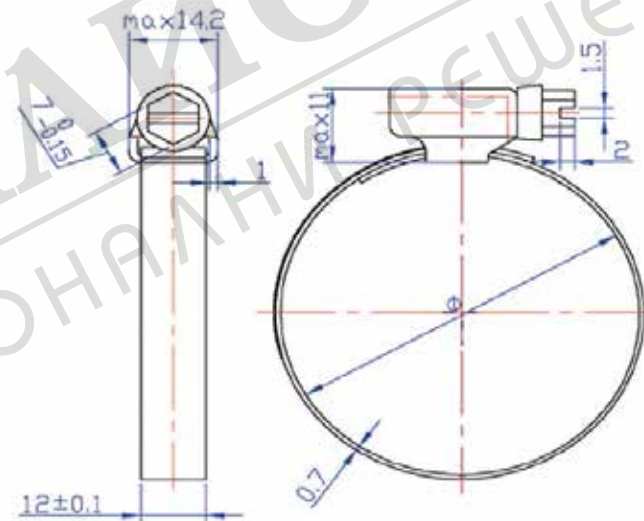

Banda con bordo rialzato e superficie interna piana, per evitare danneggiamenti al tubo.

Viti in acciaio inossidabile, sottoposte ad un ulteriore trattamento di zincatura (CR+3), per evitare il fenomeno del "Grippaggio"

With edge raised band and plani inner surface to avoid damages at the hose.

Stainless Steel screws, submitted to a further galvanizing treatment (zinc plated CR+3) in order to avoid "Seizing"

last edit 19/02/2019

DRAWING N. 1021