

DIN 934 sim. UNI 5588 EN ISO 4032

Dado esagonale medio

Hexagon regular nut

Disponibile
Available

A2 

A4 

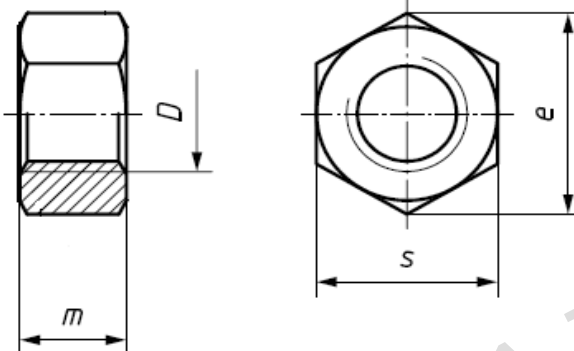

D		M1x0,25	M1,2x0,25	M1,4x0,3	M1,6x0,35	M2x0,4	M2,5x0,45	M3x0,5	(M3,5x0,6)	M4x0,7
m	max=nom.	0,8	1	1,2	1,3	1,6	2	2,4	2,8	3,2
	min.	0,55	0,75	0,95	1,05	1,35	1,75	2,15	2,55	2,9
s	max=nom.	2,5	3	3	3,2	4	5	5,5	6	7
	min.	2,4	2,9	2,9	3,02	3,82	4,82	5,32	5,82	6,78
e	min.	2,71	3,28	3,28	3,41	4,32	5,45	6,01	6,58	7,66
D		M5x0,8	M6x1	(M7x1)	M8x1,25	M10x1,5	M12x1,75	(M14x2)	M16x2	(M18x2,5)
					M8x1	M10x1	M12x1,5	(M14x1,5)	(M16x1,5)	(M18x1,5)
						M10x1,25	M12x1,25			(M18x2)
m	max=nom.	4	5	5,5	6,5	8	10	11	13	15
	min.	3,7	4,7	5,2	6,14	7,64	9,64	10,3	12,3	14,3
s	max=nom.	8	10	11	13	17	19	22	24	27
	min.	7,78	9,78	10,73	12,73	16,73	18,67	21,67	23,67	26,16
e	min.	8,79	11,05	12,12	14,38	18,9	21,1	24,49	26,75	29,56

last edit 27/05/2020

Pag. 1/2

DRAWING N. 1152

D		M20x2,5	(M22x2,5)	M24x3	(M27x3)	M30x3,5	(M33x3,5)	M36x4	(M39x4)	M42x4,5
		M20x2	(M22x1,5)	M24x2	(M27x2)	M30x2	(M33x2)	M36x3	(M39x3)	M42x3
		M20x1,5	(M22x2)							
m	max=nom.	16	18	19	22	24	26	29	31	34
	min.	14,9	16,9	17,7	20,7	22,7	24,7	27,4	29,4	32,4
s	max=nom.	30	32	36	41	46	50	55	60	65
	min.	29,16	31	35	40	45	49	53,8	58,8	63,1
e	min.	32,95	35,03	39,55	45,20	50,85	55,37	60,79	66,44	71,3

D		(M45x4,5)	M48x5	(M52x5)	M56x5,5	(M60x5,5)	M64x6	(M68x6)	M72x6	M76x6
		(M45x3)	M48x3	(M52x3)	M56x4	(M60x4)	M64x4	(M68x4)	M72x4	M76x4
m	max=nom.	36	38	42	45	48	51	54	58	61
	min.	34,4	36,4	40,4	43,4	46,4	49,1	52,1	56,1	59,1
s	max=nom.	70	75	80	85	90	95	100	105	110
	min.	68,1	73,1	78,1	82,8	87,8	92,8	97,8	102,8	107,8
e	min.	76,95	82,6	88,25	93,56	99,21	104,86	110,51	116,16	121,81

D		M80x6	(M85x6)	M90x6	M100x6	M110x6	M125x6	M140x6	M160x6	
		M80x4	(M85x4)	M90x4	M100x4	M110x4	M125x4			
m	max=nom.	64	68	72	80	88	100	112	128	
	min.	62,1	66,1	70,1	78,1	85,8	97,8	109,8	125,5	
s	max=nom.	115	120	130	145	155	180	200	230	
	min.	112,8	117,8	127,5	142,5	152,5	177,5	195,4	225,4	
e	min.	127,46	133,11	144,08	161,02	172,32	200,57	220,80	254,70	

Se possibile, evitare le dimensioni tra parentesi
The size in brackets should be avoided if possible

Disponibili anche con filetto sinistro
Available also with Left thread (LH)