



**WACKER
NEUSON**
all it takes!

Operator's manual



Breaker

BH



Machine Type
Material number
Version
Date
Language

BH23, BH55, BH65
5100056213
4
12/2020
[us]



Imprint

Publisher and copyright holder:

Wacker Neuson Produktion GmbH & Co. KG

Wackerstraße 6

85084 Reichertshofen,

Registered office: Reichertshofen

Register court and number: Local Court Ingolstadt, HRA3195

VAT ID No./VAT Number: DE277138620

Telephone: +49 (0) 8453-3403200

www.wackerneuson.com

Original operator's manual

All rights reserved, in particular the copyright, the right of reproduction and the right of distribution applicable worldwide.

This document may be used by the recipient only for the designated purpose. It may in no way be duplicated or translated in any other language, in whole or in part, without prior permission in writing from the manufacturer.

Reproduction or translation of this publication, in whole or part, is not permitted without the written consent of Wacker Neuson Produktion GmbH & Co. KG.

Violations of legal regulations, in particular of the copyright protection, will be subject to civil and criminal prosecution.

Wacker Neuson Produktion GmbH & Co. KG reserves the right to change its products and their technical specifications for further technical development at any time without any claim to changes to machines already delivered. The information in the technical documentation supplied with the product applies in each case.

The machine on the cover is for illustration purposes only and may therefore have special equipment (options).

Wacker Neuson Produktion GmbH & Co. KG, responsibility for errors or omissions not accepted, printed in Germany

Copyright © 2020

California Proposition 65 Warning



⚠ WARNING

The engine exhaust from this product contains chemicals known to the State of California to cause cancer, birth defects, or other reproductive harm.



⚠ WARNING

Diesel engine exhaust and some of its constituents are known to the State of California to cause cancer, birth defects, and other reproductive harm.



⚠ WARNING

Cancer and Reproductive Harm -
www.P65Warnings.ca.gov.



⚠ WARNING

Batteries, battery posts, terminals and related accessories contain lead and lead compounds, and other chemicals known to the State of California to cause cancer and birth defects or other reproductive harm. WASH HANDS AFTER HANDLING.

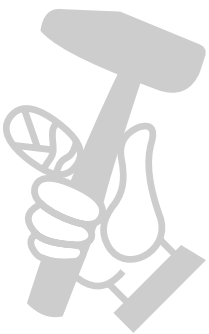
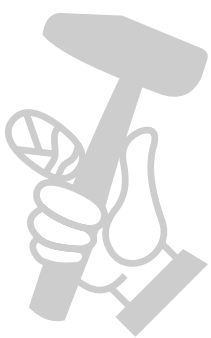

Table of Contents

1	EC Declaration of Conformity	
2	Preface	
2.1	Introduction	17
2.2	Storage location of the operator's manual	17
2.3	Accident prevention regulations	18
2.4	Wacker Neuson Contact	19
2.5	Limitation of liability	19
2.6	Labeling on the machine	19
2.7	Use of the operator's manual	19
3	Usage	
3.1	Designated use	21
3.2	Unintended use	21
4	Safety	
4.1	Safety symbols and signal words	22
4.2	Principle	22
4.3	Structural changes	23
4.4	Responsibility of the operator	23
4.5	Obligations of the operator	24
4.6	Qualification of staff	24
4.7	General safety instructions	24
4.8	Maintenance	26
4.9	Safety features	27
5	Description of the Machine	
5.1	Safety and information labels	29
5.2	Components	30
5.3	Control elements	31
6	Transportation	
6.1	Emptying the fuel system	33
6.2	Carrying out preparations	33
6.3	Transporting the machine	33
7	Commissioning	
7.1	Putting into operation for the first time	35
7.2	Tests before commissioning	35
7.3	Changing tools	35
7.4	Setting the machine	37
8	Operation	
8.1	Putting into operation	38
8.2	Operating the machine	41

8.3	Putting out of operation.....	42
9	Maintenance	
9.1	Maintenance plan	43
9.2	Maintenance work.....	43
10	Malfunctions	
10.1	Troubleshooting	49
11	Storage	
11.1	Carrying out preparations	50
11.2	Emptying the fuel system.....	50
11.3	Storing the machine.....	50
12	Accessories	
12.1	Transport trolley.....	51
13	Technical Data	
13.1	General instructions.....	53
13.2	Noise and vibration data	53
13.3	BH23.....	53
13.4	BH55.....	54
13.5	BH55rw	55
13.6	BH65.....	56
13.7	Combustion engine WM80c.....	58



МАГАЗИН МАЙСТОРА
 БАШ МАЙСТОРА
 ПРОФЕСІОНАЛНИ РЕШЕННЯ



EC Declaration of Conformity

Manufacturer

Wacker Neuson Produktion GmbH & Co. KG, Wackerstraße 6, D-85084 Reichertshofen
This declaration of conformity is issued under the sole responsibility of the manufacturer.



Product	BH23
Product type	Demolition breakers
Function of product	Breaking up materials
Material number	5100060159
Weight	22,8 kg
Measured sound power level	106 dB(A)
Guaranteed sound power level	109 dB(A)

Conformity assessment procedure

2000/14/EC, Annex VIII

Notified body

TÜV Rheinland LGA Products GmbH, Tillystr. 2, D-90431 Nürnberg (NB 0197)

Guidelines and standards

We hereby declare that this product complies with the relevant provisions and requirements of the following directives and standards:

2006/42/EC, 2000/14/EC, 2014/30/EU, EN 55012:2007 + A1:2009, EN ISO 11148-4:2012

Person responsible for technical documents

Wacker Neuson Produktion GmbH & Co. KG, Wackerstraße 6, D-85084 Reichertshofen

Reichertshofen, 04.12.2020

Helmut Bauer
Managing Director



EC Declaration of Conformity

Manufacturer

Wacker Neuson Produktion GmbH & Co. KG, Wackerstraße 6, D-85084 Reichertshofen
This declaration of conformity is issued under the sole responsibility of the manufacturer.

Product	BH55
Product type	Demolition breakers
Function of product	Breaking up materials
Material number	5100047063
Weight	22,8 kg
Measured sound power level	107 dB(A)
Guaranteed sound power level	109 dB(A)

Conformity assessment procedure

2000/14/EC, Annex VIII

Notified body

TÜV Rheinland LGA Products GmbH, Tillystr. 2, D-90431 Nürnberg (NB 0197)

Guidelines and standards

We hereby declare that this product complies with the relevant provisions and requirements of the following directives and standards:

2006/42/EC, 2000/14/EC, 2014/30/EU, EN 55012:2007 + A1:2009, EN ISO 11148-4:2012

Person responsible for technical documents

Wacker Neuson Produktion GmbH & Co. KG, Wackerstraße 6, D-85084 Reichertshofen

Reichertshofen, 19.06.2019

Helmut Bauer
Managing Director



EC Declaration of Conformity

Manufacturer

Wacker Neuson Produktion GmbH & Co. KG, Wackerstraße 6, D-85084 Reichertshofen
This declaration of conformity is issued under the sole responsibility of the manufacturer.

Product	BH55
Product type	Demolition breakers
Function of product	Breaking up materials
Material number	5100047104
Weight	22,7 kg
Measured sound power level	107 dB(A)
Guaranteed sound power level	109 dB(A)

Conformity assessment procedure

2000/14/EC, Annex VIII

Notified body

TÜV Rheinland LGA Products GmbH, Tillystr. 2, D-90431 Nürnberg (NB 0197)

Guidelines and standards

We hereby declare that this product complies with the relevant provisions and requirements of the following directives and standards:

2006/42/EC, 2000/14/EC, 2014/30/EU, EN 55012:2007 + A1:2009, EN ISO 11148-4:2012

Person responsible for technical documents

Wacker Neuson Produktion GmbH & Co. KG, Wackerstraße 6, D-85084 Reichertshofen

Reichertshofen, 19.06.2019

Helmut Bauer
Managing Director



EC Declaration of Conformity

Manufacturer

Wacker Neuson Produktion GmbH & Co. KG, Wackerstraße 6, D-85084 Reichertshofen
This declaration of conformity is issued under the sole responsibility of the manufacturer.

Product	BH55
Product type	Demolition breakers
Function of product	Breaking up materials
Material number	5100047105
Weight	23,8 kg
Measured sound power level	107 dB(A)
Guaranteed sound power level	109 dB(A)

Conformity assessment procedure

2000/14/EC, Annex VIII

Notified body

TÜV Rheinland LGA Products GmbH, Tillystr. 2, D-90431 Nürnberg (NB 0197)

Guidelines and standards

We hereby declare that this product complies with the relevant provisions and requirements of the following directives and standards:

2006/42/EC, 2000/14/EC, 2014/30/EU, EN 55012:2007 + A1:2009, EN ISO 11148-4:2012

Person responsible for technical documents

Wacker Neuson Produktion GmbH & Co. KG, Wackerstraße 6, D-85084 Reichertshofen

Reichertshofen, 19.06.2019



Helmut Bauer
Managing Director



EC Declaration of Conformity

Manufacturer

Wacker Neuson Produktion GmbH & Co. KG, Wackerstraße 6, D-85084 Reichertshofen
This declaration of conformity is issued under the sole responsibility of the manufacturer.

Product	BH55rw
Product type	Demolition breakers
Function of product	Tamping and compaction work in railway construction
Material number	5100047100, 5100047103
Weight	24,2 kg
Measured sound power level	106 dB(A)
Guaranteed sound power level	109 dB(A)

Conformity assessment procedure

2000/14/EC, Annex VIII

Notified body

TÜV Rheinland LGA Products GmbH, Tillystr. 2, D-90431 Nürnberg (NB 0197)

Guidelines and standards

We hereby declare that this product complies with the relevant provisions and requirements of the following directives and standards:

2006/42/EC, 2000/14/EC, 2014/30/EU, EN 55012:2007 + A1:2009, EN ISO 11148-4:2012

Person responsible for technical documents

Wacker Neuson Produktion GmbH & Co. KG, Wackerstraße 6, D-85084 Reichertshofen

Reichertshofen, 19.06.2019

Helmut Bauer
Managing Director



EC Declaration of Conformity

Manufacturer

Wacker Neuson Produktion GmbH & Co. KG, Wackerstraße 6, D-85084 Reichertshofen
This declaration of conformity is issued under the sole responsibility of the manufacturer.

Product	BH55rw
Product type	Demolition breakers
Function of product	Tamping and compaction work in railway construction
Material number	5100047102
Weight	25,1 kg
Measured sound power level	106 dB(A)
Guaranteed sound power level	109 dB(A)

Conformity assessment procedure

2000/14/EC, Annex VIII

Notified body

TÜV Rheinland LGA Products GmbH, Tillystr. 2, D-90431 Nürnberg (NB 0197)

Guidelines and standards

We hereby declare that this product complies with the relevant provisions and requirements of the following directives and standards:

2006/42/EC, 2000/14/EC, 2014/30/EU, EN 55012:2007 + A1:2009, EN ISO 11148-4:2012

Person responsible for technical documents

Wacker Neuson Produktion GmbH & Co. KG, Wackerstraße 6, D-85084 Reichertshofen

Reichertshofen, 19.06.2019

Helmut Bauer
Managing Director



EC Declaration of Conformity

Manufacturer

Wacker Neuson Produktion GmbH & Co. KG, Wackerstraße 6, D-85084 Reichertshofen
This declaration of conformity is issued under the sole responsibility of the manufacturer.



Product	BH55rw
Product type	Demolition breakers
Function of product	Tamping and compaction work in railway construction
Material number	5100047101
Weight	25,2 kg
Measured sound power level	106 dB(A)
Guaranteed sound power level	109 dB(A)

Conformity assessment procedure

2000/14/EC, Annex VIII

Notified body

TÜV Rheinland LGA Products GmbH, Tillystr. 2, D-90431 Nürnberg (NB 0197)

Guidelines and standards

We hereby declare that this product complies with the relevant provisions and requirements of the following directives and standards:

2006/42/EC, 2000/14/EC, 2014/30/EU, EN 55012:2007 + A1:2009, EN ISO 11148-4:2012

Person responsible for technical documents

Wacker Neuson Produktion GmbH & Co. KG, Wackerstraße 6, D-85084 Reichertshofen

Reichertshofen, 19.06.2019

Helmut Bauer
Managing Director



EC Declaration of Conformity

Manufacturer

Wacker Neuson Produktion GmbH & Co. KG, Wackerstraße 6, D-85084 Reichertshofen
This declaration of conformity is issued under the sole responsibility of the manufacturer.

Product	BH65
Product type	Demolition breakers
Function of product	Breaking up materials
Material number	5100047068, 5100051587
Weight	25,2 kg
Measured sound power level	106 dB(A)
Guaranteed sound power level	109 dB(A)

Conformity assessment procedure

2000/14/EC, Annex VIII

Notified body

TÜV Rheinland LGA Products GmbH, Tillystr. 2, D-90431 Nürnberg (NB 0197)

Guidelines and standards

We hereby declare that this product complies with the relevant provisions and requirements of the following directives and standards:

2006/42/EC, 2000/14/EC, 2014/30/EU, EN 55012:2007 + A1:2009, EN ISO 11148-4:2012

Person responsible for technical documents

Wacker Neuson Produktion GmbH & Co. KG, Wackerstraße 6, D-85084 Reichertshofen

Reichertshofen, 19.06.2019

Helmut Bauer
Managing Director



EC Declaration of Conformity

Manufacturer

Wacker Neuson Produktion GmbH & Co. KG, Wackerstraße 6, D-85084 Reichertshofen
This declaration of conformity is issued under the sole responsibility of the manufacturer.

Product	BH65
Product type	Demolition breakers
Function of product	Breaking up materials
Material number	5100047069
Weight	25,1 kg
Measured sound power level	106 dB(A)
Guaranteed sound power level	109 dB(A)

Conformity assessment procedure

2000/14/EC, Annex VIII

Notified body

TÜV Rheinland LGA Products GmbH, Tillystr. 2, D-90431 Nürnberg (NB 0197)

Guidelines and standards

We hereby declare that this product complies with the relevant provisions and requirements of the following directives and standards:

2006/42/EC, 2000/14/EC, 2014/30/EU, EN 55012:2007 + A1:2009, EN ISO 11148-4:2012

Person responsible for technical documents

Wacker Neuson Produktion GmbH & Co. KG, Wackerstraße 6, D-85084 Reichertshofen

Reichertshofen, 19.06.2019

Helmut Bauer
Managing Director



EC Declaration of Conformity

Manufacturer

Wacker Neuson Produktion GmbH & Co. KG, Wackerstraße 6, D-85084 Reichertshofen
This declaration of conformity is issued under the sole responsibility of the manufacturer.



Product	BH65
Product type	Demolition breakers
Function of product	Breaking up materials
Material number	5100047106
Weight	24,2 kg
Measured sound power level	106 dB(A)
Guaranteed sound power level	109 dB(A)

Conformity assessment procedure

2000/14/EC, Annex VIII

Notified body

TÜV Rheinland LGA Products GmbH, Tillystr. 2, D-90431 Nürnberg (NB 0197)

Guidelines and standards

We hereby declare that this product complies with the relevant provisions and requirements of the following directives and standards:

2006/42/EC, 2000/14/EC, 2014/30/EU, EN 55012:2007 + A1:2009, EN ISO 11148-4:2012

Person responsible for technical documents

Wacker Neuson Produktion GmbH & Co. KG, Wackerstraße 6, D-85084 Reichertshofen

Reichertshofen, 19.06.2019

Helmut Bauer
Managing Director



EC Declaration of Conformity

Manufacturer

Wacker Neuson Produktion GmbH & Co. KG, Wackerstraße 6, D-85084 Reichertshofen
This declaration of conformity is issued under the sole responsibility of the manufacturer.

Product	BH65
Product type	Demolition breakers
Function of product	Breaking up materials
Material number	5100047107
Weight	24,1 kg
Measured sound power level	106 dB(A)
Guaranteed sound power level	109 dB(A)

Conformity assessment procedure

2000/14/EC, Annex VIII

Notified body

TÜV Rheinland LGA Products GmbH, Tillystr. 2, D-90431 Nürnberg (NB 0197)

Guidelines and standards

We hereby declare that this product complies with the relevant provisions and requirements of the following directives and standards:

2006/42/EC, 2000/14/EC, 2014/30/EU, EN 55012:2007 + A1:2009, EN ISO 11148-4:2012

Person responsible for technical documents

Wacker Neuson Produktion GmbH & Co. KG, Wackerstraße 6, D-85084 Reichertshofen

Reichertshofen, 19.06.2019

Helmut Bauer
Managing Director

2 Preface

2.1 Introduction

This operator's manual contains important information and procedures for the safe, proper and economical operation of this Wacker Neuson machine. Carefully reading, understanding and observing it helps to avoid dangers, reduce repair costs and downtimes and thus increase the availability and service life of the machine.

This operator's manual is not a manual for extensive maintenance or repair work. Such work must be carried out by Wacker Neuson Service or by technically trained personnel. The Wacker Neuson machine must be operated and maintained in accordance with the instructions in this operator's manual. Improper operation or maintenance can cause hazards.

Defective machine parts must be replaced immediately.

Wacker Neuson contact persons are always available to answer questions about operation or maintenance.

2.2 Storage location of the operator's manual

This operator's manual must be kept in the immediate vicinity of the machine and accessible to personnel at all times.

If this operator's manual is lost or you require a new copy, there are two ways of obtaining a replacement:

- You can download it from the Internet - <http://www.wackerneuson.com>
- Or you can contact your Wacker Neuson representative.

2.2.1 Understanding these instructions

This section helps to understand the operator's manual and the illustrations used therein.

Target group

People working with this machine must be regularly trained with regard to the dangers and risks occurring when using this machine.

This operator's manual is aimed at:

- Operating personnel:
 - These people have been instructed in working with the machine and about possible dangers and risks arising due to improper behavior.
- Technically trained personnel:
 - These people have a professional training as well as additional knowledge and experience. They are capable of assessing the tasks assigned to them and recognizing any possible risks and dangers.

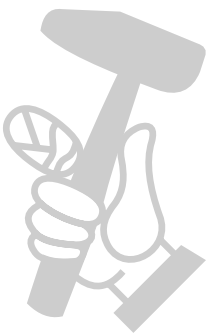

Explanation of symbols

Symbol	Explanation
1., 2., 3...	Indicates an activity. The sequence of the steps must be observed.
⇒	Indicates a result or an intermediate result of an action.
✓	Indicates prerequisites that must be established for the activity.
•	Indicates a list, e.g. if several components are named one after the other.
-	Indicates a sub-list, e.g. if components consist of further components
	Identifies a position, usually a component or control element, in a graphic. The numbering may be sequential or in Roman numerals.
1; A	Indicates the naming of components in explanatory texts. It is identical with the adjacent positions in the illustrations.
	Indicates a direction of movement or different positions for switches.
▶	Indicates the avoidance of hazards in warning notices.
[▶52]	Indicates a cross-reference in tables. Here e.g. reference to page 52

2.2.1.1 Explanation of symbols

The symbols used in the operator's manual are explained below. The symbols are used exclusively in warning or environmental instructions or information. Warnings must always be observed to protect the operator and third parties from personal injury and damage to property.



Symbol for warning notices

This symbol marks general warnings. It is used to alert you of possible dangers, e.g. risks of injury or accidents.



Symbol for indications of technical damage

This symbol is a warning symbol that indicates a danger of technical damage. It is used to indicate situations where damage to the machine or third-party property may occur.



Symbol for environmental information

This symbol indicates environmental information. It is used to warn of possible environmental hazards.



Symbol for information

This symbol indicates information. This information can include tips on operation, for example. It helps to better understand and use the machine.

2.3 Accident prevention regulations

In addition to the notes and safety instructions in this operator's manual, the local accident prevention regulations and the national industrial safety regulations apply.

2.4 Wacker Neuson Contact

Depending on the country, the Wacker Neuson contact is a Wacker Neuson Service, a Wacker Neuson subsidiary or a Wacker Neuson dealer.

On the Internet at - <http://www.wackerneuson.com>.

2.5 Limitation of liability

In the event of the following infringements, the manufacturer disclaims any liability for personal injury and damage to property:

- Actions contrary to this operator's manual.
- Non-designated use
- Deployment of untrained personnel.
- Use non-approved spare parts and accessories.
- Improper handling.
- Structural changes of any kind.
- Non-observance of the General Terms and Conditions (GTC).

2.6 Labeling on the machine

Type label data

The type label contains information that uniquely identifies this machine. This information is required for ordering spare parts and for technical queries.

Enter the data on the machine in the following table:

Designation	Your details
Group - Type	
Material number (Mat. no.)	
Machine version (version)	
Machine number (machine no.)	
Year of construction	

2.7 Use of the operator's manual

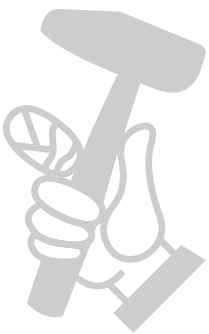

This operator's manual:

- must be regarded as an integral part of the machine and must be kept in a safe place throughout its service life.
- must be passed on to each subsequent owner or operator of this machine.
- applies to various machine types from one product range. For this reason, some illustrations may differ from the appearance of the purchased machine. Variant-dependent components that are not included in the scope of delivery can also be described.

Wacker Neuson reserves the right to change the information in this operator's manual without notice.

It must be ensured that any changes or additions made by the manufacturer are immediately incorporated into this operator's manual.



Group - Type	Material number (Mat. no.)
BH23 27x80 CN	5100060159
BH55 27x80	5100047063
BH55 25x108	5100047104
BH55 28x160	5100047105
BH55rw 27x80	5100047100
BH55rw 28x160	5100047101
BH55rw 32x160	5100047102
BH55rw rs 27x80	5100047103
BH65 25x108	5100047107
BH65 27x80	5100047106
BH65 28x160	5100047068
BH65 28x160	5100051587
BH65 32x160	5100047069
Accessories consist of: <ul style="list-style-type: none"> • Chisel program • Transport trolley 	Accessories must be ordered separately.

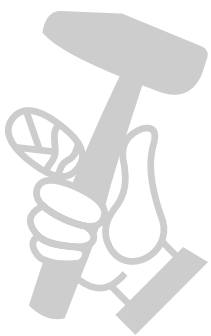

МАГАЗИН
БАШ МАЙС
ПРОФЕСИОНАЛНИ РЕШЕНИЯ

3 Usage

3.1 Designated use

Designated use also includes observing all notes and safety instructions in this operator's manual and observing the prescribed care and maintenance instructions.

The machine is used for:

- Breaking up of concrete and asphalt as well as soil interspersed with scree.
- Demolition of concrete, masonry and other building materials, grown and frozen soil.
- Tearing open roads and concrete, asphalt, tar, wood and stone paving.
- Cutting off clay, loam, peat and salts.
- Crushing of solidified or crushed soils.
- Ramming in piles, probes and grounding rods.
- Tamping of sleepers in track construction.

The machine may only be operated with tools intended for the machine and the material to be machined.

Any other use or use that goes beyond this is considered improper use. The manufacturer shall not be liable or liable for any damage resulting therefrom. The risk is borne solely by the operator.

3.2 Unintended use

The manufacturer is not liable for personal injury or damage to property resulting from unintended use. The following activities, among others, are not intended:

- Processing of materials hazardous to health, e.g. asbestos.
- Operating the machine outside the performance data.
- Working in potentially explosive atmospheres.
- Working in closed rooms or work in partially closed rooms without adequate ventilation.
- Operation contrary to the notes and safety instructions contained in the operator's manual attached to the machine.
- Structural changes.

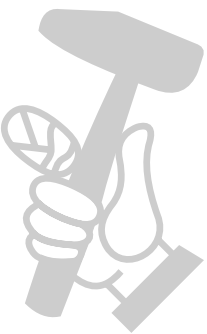

4 Safety

4.1 Safety symbols and signal words

The following symbol identifies safety instructions. It is used for warning against potential personal risk or danger.



⚠ DANGER

DANGER identifies a situation causing death or serious injury if it is not avoided.

Consequences in case of non-observance.

- ▶ Avoidance of injury or death.



⚠ WARNING

WARNING identifies a situation that can cause death or serious injury if it is not avoided.

Consequences in case of non-observance.

- ▶ Avoidance of injury or death.



⚠ CAUTION

CAUTION identifies a situation that can cause injury if it is not avoided.

Consequences in case of non-observance.

- ▶ Avoidance of injury.



NOTICE

INFORMATION identifies a situation that causes damage if it is not observed.

Consequences in case of non-observance

- ▶ Avoidance of damage to property.

4.2 Principle

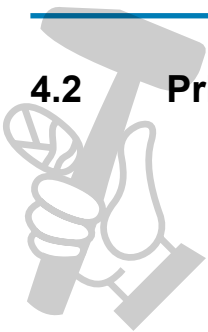

The machine has been designed and built in accordance with latest state-of-the-art standards and the recognized safety regulations. Nevertheless, improper use may result in danger to life and limb of the operator, third parties or damage to the machine and other material property.

Read and observe the notes and safety instructions in this operator's manual. Failure to follow these instructions may result in electric shock, fire and/or serious injury, and damage to the machine and/or other objects.

Keep safety instructions and information for the future.

4.3 Structural changes

Structural modifications may not be made without the written consent of the manufacturer. Unauthorized structural changes may result in hazards to the operator and/or third parties as well as damage to the machine.

The manufacturer's liability and warranty are also void in the event of unauthorized structural alterations.

In particular, a structural change shall be deemed to have occurred:

- When opening of the machine and permanent removal of components.
- Installation of spare parts that do not come from Wacker Neuson or are not equivalent in design and quality to the original parts.
- Attachment of accessories of any kind that do not originate from Wacker Neuson.

Spare parts or accessories from Wacker Neuson can be installed or removed safely. Further information is available on the Internet at - <http://www.wackerneuson.com>.

4.4 Responsibility of the operator

The operator is the person who operates this machine himself for commercial or economic purposes or who leaves it to a third party for use/application and bears the legal product responsibility for the protection of personnel or third parties during operation.

The operator must make the operator's manual accessible to the personnel at all times and ensure that the operator has read and understood the operator's manual.

The operator's manual must be kept ready to hand at the machine or at the place of use.

The operator must hand over the operator to any other operator or subsequent owner of the machine.

The country-specific regulations, standards and directives on accident prevention and environmental protection must also be observed. The operator's manual must be supplemented by further instructions for compliance with operational, official, national or generally applicable safety guidelines.

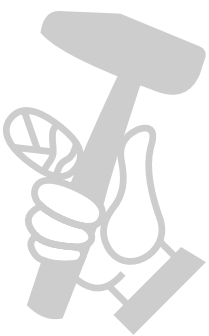

4.5 Obligations of the operator

- Know and implement applicable health and safety regulations.
- In a risk assessment, identify hazards arising from working conditions at the place of use.
- Create operating instructions for the operation of this machine.
- Regularly check whether the operating instructions correspond to the current status of the regulations.
- Clearly regulate and define responsibilities for installation, operation, troubleshooting, maintenance and cleaning.
- Train personnel at regular intervals and inform them about possible dangers.
- Refresh instruction at regular intervals.
- Keep records of the training received and make them available to the competent authority on request.
- Provide personnel with the necessary protective equipment.

4.6 Qualification of staff

This machine may only be put into operation and operated by trained personnel.

In the event of misuse, abuse or operation by untrained personnel, there is a danger to the health of the operators and/or third parties, as well as damage or total failure of the machine.

In addition, the following requirements apply to the operator:

- Physical and mental suitability.
- Minimum age 18 years.
- No influence on reactivity by drugs, alcohol or medication.
- Familiarity with the safety instructions in this operator's manual.
- Familiarity with the intended use of this machine.
- Instructed in the independent operation of the machine.

4.7 General safety instructions

The safety instructions in this chapter contain the "General safety instructions", which must be listed in the operator's manual in accordance with the applicable standards. It may contain instructions which are not relevant for this machine.

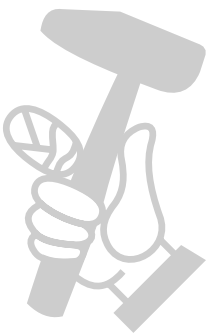

4.7.1 Workplace

- Before starting work, familiarize yourself with the working environment, e.g. load-bearing capacity of the floor or obstacles in the environment.
- Secure work area to public transport area.
- Necessary protection of walls and ceilings, e.g. in trenches.
- Keep unauthorized persons and children away when working with this machine. Distraction may result in loss of control of the machine, work must be carried out carefully.
- Always secure the machine against tipping, rolling, slipping and falling. Risk of injury!
- Keep work area tidy. Disorder or unlit work areas can lead to accidents.

4.7.2 Personal safety

- Working under the influence of drugs, alcohol or medication can lead to serious injuries.
- Suitable protective equipment must be worn for all work. Personal protective equipment considerably reduces the risk of injury.
- Keep wide or loose clothing, protective gloves, jewelry and long hair away from moving machine parts. Danger of being drawn in!
- Remove tools before commissioning the machine. Tools which are located on a rotating machine part can be ejected and lead to serious injuries.
- Always ensure that you are standing in a stable position, always stand with both feet on the ground.
- During prolonged work with this machine, long-term vibration-related damage cannot be ruled out completely. Vibration load, [see Technical Data on page 53](#).
- Ensure that there are no other persons in the danger zone!

Personal protective equipment



▲ WARNING

Risk of hearing damage if the country-specific noise limit is exceeded!

Working with the machine without hearing protection can lead to hearing damage in the long-term.

- ▶ Wear ear protectors.
- ▶ Work attentively and cautiously when using hearing protection.

4.7.3 Handling and use

- Handle machines with care. Do not operate machines whose components or control elements are defective. Have defective components or control elements replaced immediately. Machines with defective components or control elements entail a high risk of injury!
- Do not lock, manipulate or alter the machine operating elements in an inadmissible manner.
- Secure unused machines against unauthorized putting into operation. The machine may only be operated by authorized personnel.
- Handle machine with care. Have defective parts replaced immediately before this machine is commissioned. Defective machines entail a high risk of injury.
- Use the machine, accessories, tools etc. in accordance with these instructions.
- After operation, store the machine in a locked, clean, frost-protected, and dry location that is inaccessible to other persons and children.

4.8 Maintenance

- The machine must not be serviced, repaired, adjusted or cleaned when switched on.
- Observe maintenance intervals according to maintenance plan. Have work that is not listed performed by a service partner.
- Replace worn or damaged machine parts immediately. Only use spare parts from the manufacturer.
- Keep the machine clean.
- Replace any missing, damaged or illegible safety labels immediately. Safety and information labels contain important information for the protection of the operator.
- Carry out maintenance work in a clean and dry environment (e.g. workshop).

4.8.1 Service

- Only have the machine repaired or serviced by technically trained personnel.
- Only use original spare parts and accessories. The operational safety of the machine is thus maintained.

4.8.1.1 Threaded fittings



All threaded fittings must comply with the specified specifications and be firmly bolted together. Observe the tightening torques! Screws and nuts must not be damaged, bent or deformed.

Particular attention should be paid to the following:

- Self-locking nuts and micro-encapsulated screws must not be reused after loosening. The fastening effect is lost.
- Threaded fittings with adhesive protection/liquid adhesives (e.g. Loctite) must be cleaned after loosening and provided with new adhesive.



Information

Observe the instructions of the liquid adhesive manufacturer.

4.8.2 Vehicle fluids

- Always wear protective goggles and gloves when handling vehicle fluids. Seek medical advice immediately if, for example, hydraulic oil, fuel, oil or coolant gets into the eyes.
- Avoid direct skin contact with vehicle fluids. Wash skin immediately with soap and water.
- Do not eat or drink while working with vehicle fluids.
- Contaminated vehicle fluid (e.g. with dirt, water) can lead to premature wear or failure of the machine.
- Dispose of discharged or spilled vehicle fuel in accordance with applicable environmental regulations.
- If vehicle fluids leak from the machine, stop operating the machine and have it repaired immediately by a service partner.

4.8.3 Combustion engine

- Before starting work, check the engine for leaks and cracks in the fuel line, tank and filler cap.
- Do not start the defective motor. Replace damaged parts immediately.
- The preset engine speed must not be adjusted. This could lead to engine damage.
- Ensure that the exhaust system of the engine is free of flammable materials. Fire hazard!
- Before refueling, switch off the engine and let it cool down.
- Use the correct type of fuel. Observe the prescribed mixing ratios.
- Use clean filling aids for refueling. Do not spill fuel, wipe up spilled fuel immediately.
- Do not start the engine near spilled fuel. Explosion hazard!
- When operating in partially enclosed rooms, sufficient ventilation must be provided. Do not inhale exhaust gas. Danger of poisoning!
- The engine surface and exhaust system can become very hot after only a short time. Risk of burns!
- Do not use jump start sprays. These can cause misfiring and engine damage. Fire hazard!
- Smoking prohibited!

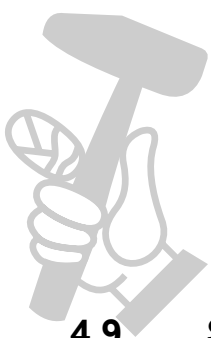

4.9 Safety features

Safety features protect the operator of this machine from being exposed to the existing hazards. These are barriers (separating protective devices) or other technical measures that serve to avert or reduce hazards.



⚠ WARNING

Hot exhaust!

Contact may cause burns.

- ▶ Only operate the machine if the safety features are correctly fitted.
- ▶ Do not change or remove safety devices.



Burn protection 1 protects the operator from radiating heat.

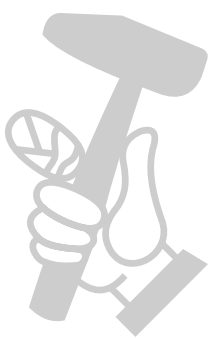

МАГАЗИН МАЙСТОРА
БАШ
ПРОФЕСИОНАЛНИ РЕШЕНИЯ

5 Description of the Machine

5.1 Safety and information labels



⚠ WARNING

Injury hazard due to missing or damaged labels and signs!

Safety labels contain important information to protect the operator.

- ▶ Keep all safety, warning and operating instructions on the machine in a clearly legible condition.
- ▶ Replace missing or damaged labels and signs immediately.

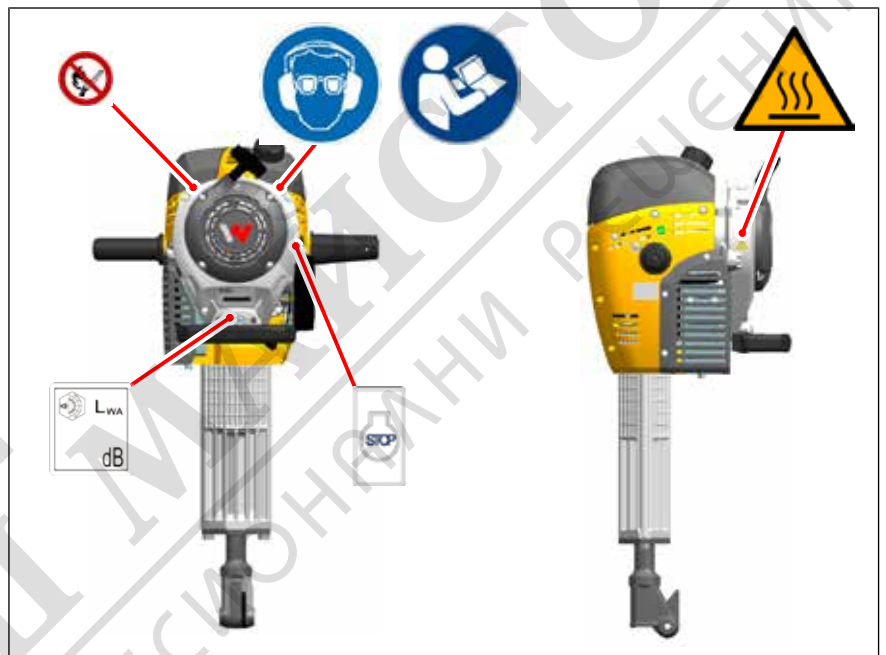

Meaning of safety labels



Fire hazard!

Smoking and open fire prohibited.



Use personal protective equipment to avoid injury and damage to health.

- Hearing protection.
- Eye protection.
- Read the operator's manual.



Off push button.

5.2 Components



Risk of burns!

Warning of hot surface.

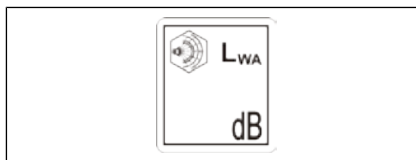

Guaranteed sound power level.

Burn protection 1 protects the operator from radiating heat.

5.2 Components

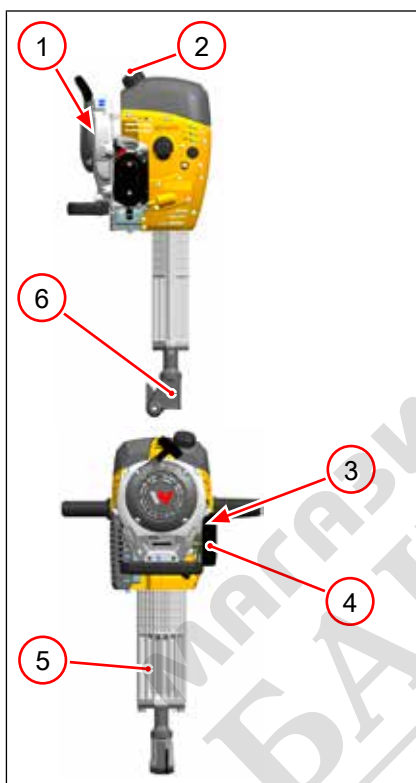

- 1 Engine
- 2 Filler cap
- 3 Carburetor
- 4 Air filter
- 5 Guide cylinder
- 6 Tool holder

Tool holder

The tool holder holds the tool.



5.3 Control elements

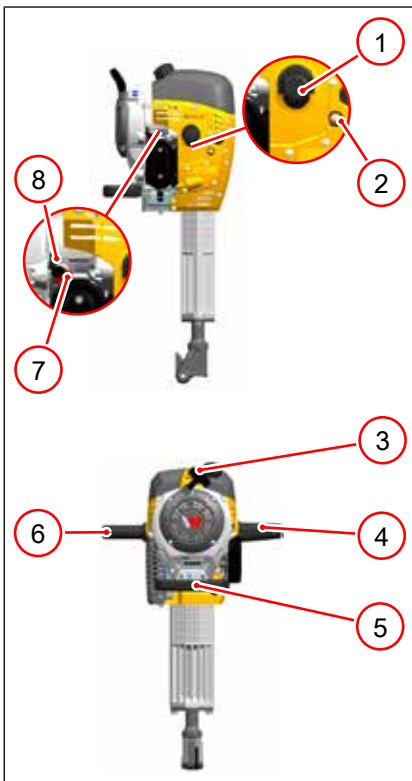

- 1 Fuel cock
- 2 Fuel pump
- 3 Reverse starter
- 4 Throttle grip
- 5 Additional handle
- 6 Handle
- 7 Choke
- 8 Off push button

Reverse starter

Have Wacker Neuson Service change the pull direction of the reversing starter if necessary (useful, for example, when driving in piles and earthing rods).

Throttle grip

The throttle grip has several positions:

- Idle position
 - Throttle grip is in home position, not depressed.
 - Engine runs at idling speed.
 - Strike mechanism is disengaged and does not strike.
- Work position
 - The machine is pressed against the material with the throttle grip depressed.
 - Engine runs at maximum speed.
 - Strike mechanism is engaged and striking.
- Machine lifted
 - The machine is lifted off the material with the throttle grip depressed.
 - Engine speed is limited.
 - Strike mechanism is engaged, but does not strike.

Additional handle



⚠ WARNING

Risk of vibration!

Danger to the operator due to increased vibration on the additional handle.

- ▶ Do not hold the machine by the additional handle during operation.

The additional handle facilitates working in an inclined position.

Wacker Neuson recommends that the machine be transported using the additional handle.



Fuel cock

The fuel cock opens or closes the fuel supply.

Off push button

The off push button switches the machine off.

Choke

When the engine is cold or hot, additionally activate the choke to enrich the fuel-air mixture.

Fuel pump

The fuel pump is used to fill the fuel lines and the carburetor. The integrated return line prevents too much fuel from entering the carburetor due to too frequent pumping.

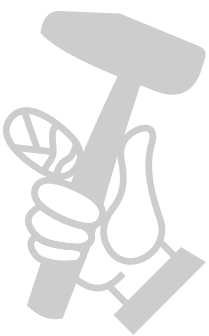

МАГАЗИН
БАШ МАЙСТОРА
ПРОФЕСИОНАЛНИ РЕШЕНИЯ

6 Transportation

6.1 Emptying the fuel system



NOTICE

Fuel leakage!

The filler cap has a pressure and vacuum valve through which fuel can escape when warm (e.g. in sunlight).

► Empty the fuel system.

- ✓ To prevent fuel leakage through the pressure relief valve, the fuel system must be empty during transport.
- 1. Remove dirt in the area of the filler cap.
- 2. Unscrew and remove the filler cap.
- 3. Pump fuel into a suitable container or tank, e.g. with a suction lift pump.
- 4. Replace filler cap and screw tight.
- 5. Start the engine and let it run at idle until the fuel in the carburetor is used up and the engine stops.

6.2 Carrying out preparations

- Switch off the engine and let it cool down.
- Remove tool.
- Drain the fuel and empty the carburetor.



Information

Fuel leakage!

► Observe the dangerous goods regulations of the means of transport and the national safety guidelines.

- Lean the machine upright against a solid object and secure against tipping over. Wacker Neuson recommends placing the machine on the transport trolley.

6.3 Transporting the machine



▲ CAUTION

Risk of injury from falling machine!

► Secure the machine against tipping over, falling down or slipping, e.g. in a closed container.



Information

Wacker Neuson recommends using the transport trolley for on-site transport, [see Accessories on page 51](#).

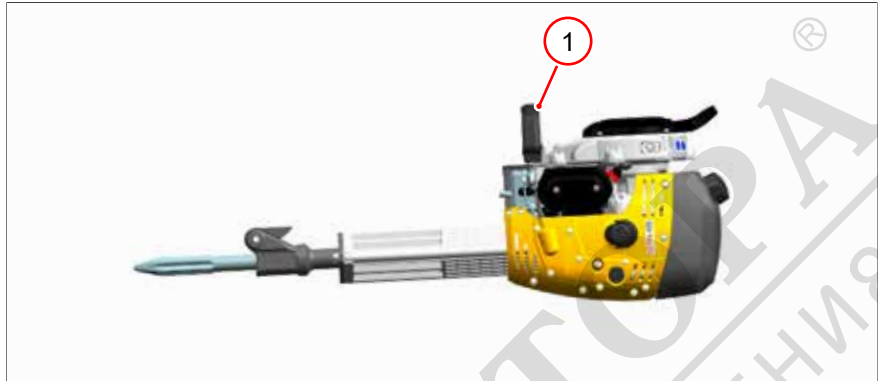

1. Lift the machine by the additional handle 1.
2. Place the machine in or on a suitable means of transport flat on the back of the hood with the additional handle pointing upwards.
3. Secure the machine against overturning, falling or slipping.

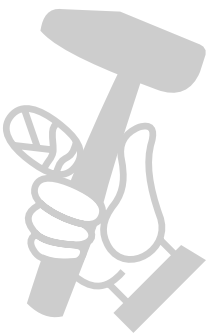

7 Commissioning

7.1 Putting into operation for the first time

7.1.1 Making the machine functional



- Plug the spark plug connector **1** onto the spark plug **2**.

7.2 Tests before commissioning



Information

Further information and detailed descriptions, [see Maintenance on page 43](#).

Perform the following checks:

- Check machine and components for damage.
 - Do not put the damaged machine into operation. Damages and defects must be repaired immediately.
- Check fuel level.
- Check fuel lines for leaks.
- Check air filter.
- Check reversing starter.
- Observe the current regulations of the local authorities regarding noise emissions.

7.3 Changing tools

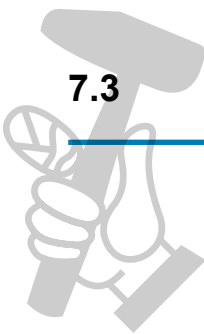

NOTICE

Information on the use of tools!

Only use tools with the following properties:

- ▶ The tool must be suitable for the tool holder.
- ▶ The tool insert must be undamaged.
- ▶ The tool must be sufficiently sharp to avoid bouncing.
- ▶ The tool must be suitable for the intended purpose.



Information

Change of tools!

No additional tools are required to change the tool.

7.3.1 Inserting and removing tools

Insert tool

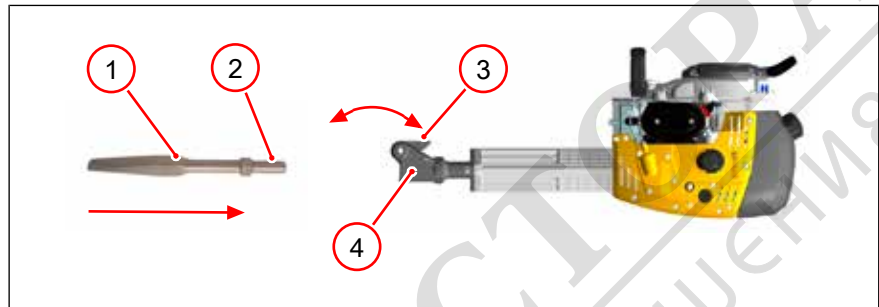

1. Clean tool insert **2**.
2. Swivel out the handle **3** on the tool holder **4**.
3. Turn tool **1** into the position that is most favorable for the planned work.
4. Push the tool into the tool holder as far as it will go.
5. Press the latch on the tool holder.
6. Pull the tool to check the lock.
 - ⇒ Locking is carried out correctly if the tool is axially movable and can no longer be pulled out.
 - The handle locks the tool in the tool holder.

Remove tool



CAUTION

Danger of burns from hot tools and guide cylinder!

- ▶ Use protective gloves.

1. Swivel out the handle **3** on the tool holder **4**.
2. Remove tool **1** from the tool holder .
3. Press the latch on the tool holder.

7.4 Setting the machine

7.4.1 Machine with integrated switch-off device - rs (optional)



Information

The short-circuit plug **1** can be inserted and stored in the handle **3**.

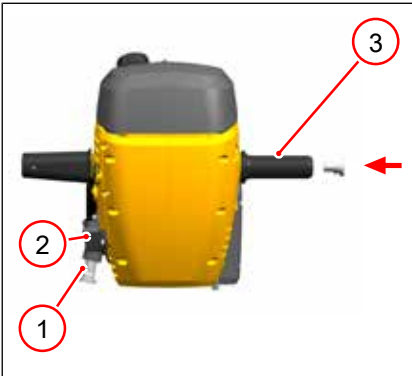

The machine is only functional if the connection bushing **2** of the integrated disconnection device is fitted with either the remote disconnection plug or the short-circuit plug **1**.

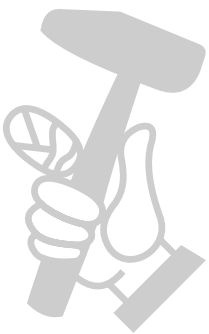

8 Operation

8.1 Putting into operation



⚠ WARNING

Risk of hearing damage if the country-specific noise limit is exceeded!

Working with the machine without hearing protection can lead to hearing damage in the long-term.

- ▶ Wear ear protectors.
- ▶ Work attentively and cautiously when using hearing protection.



NOTICE

Information on operation!

- ▶ Make use of the machine's own weight when working.
- ▶ Do not press violently against the material. This does not increase the performance of the machine.
- ▶ Press the machine so strongly against the material to be processed that the machine deflects noticeably.
- ▶ As soon as the lower stop is felt, press less strongly.



NOTICE

Information on operation at temperatures < 0°C!

The cold grease in the percussion mechanism can increase the resistance to such an extent that the centrifugal clutch slips.

- ▶ Warm up the machine at low speed (do not press the throttle grip), otherwise the centrifugal clutch will wear out within a very short time.

8.1.1 Carrying out preparations



NOTICE

- ▶ Change location to start the engine (at least 3 meters from the refueling station).

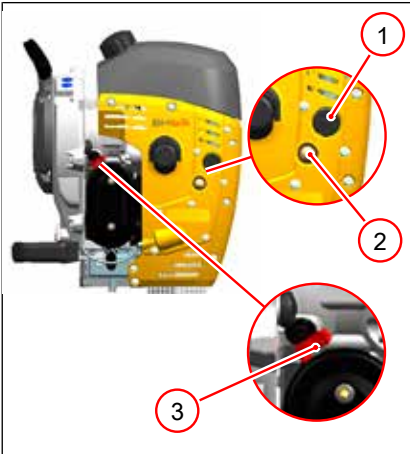

1. Place the machine upright and hold it with one hand.
2. Open the fuel cock 1.
3. Press the bellows of the fuel pump 2 about ten times, until the bellows is completely filled with fuel.
4. Choke 3 - Select the setting.



Information

- ▶ Cold engine: Move the choke to position I.
- ▶ Warm engine: Move the Choke to position II.
- ▶ Hot engine: If necessary, move the choke to position I.

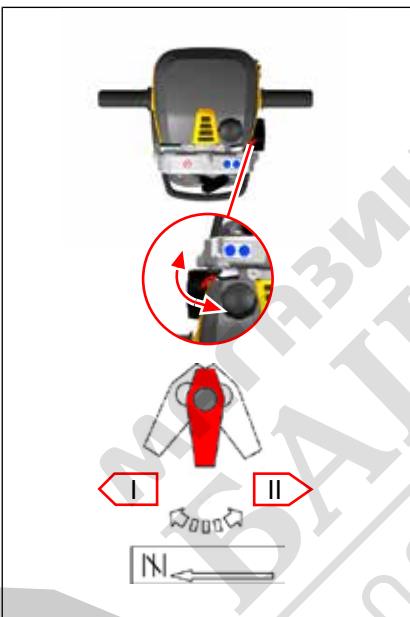

- I Choke active
- II Choke inactive

8.1.2 Starting the engine



CAUTION

Risk of injury when starting!

Improper handling during starting can lead to minor injuries.

- ▶ Do not pull the starter cable until there is sufficient space and no persons in the immediate vicinity.



⚠ CAUTION

Danger due to extreme dust generation!

Inhalation of dust can cause damage to the health of the respiratory tract.

- ▶ Use a dust mask.
- ▶ Use sprinkler.



⚠ CAUTION

Health hazard due to inhalation of exhaust gases!

Working in partially enclosed rooms without adequate ventilation can lead to poisoning.

- ▶ Use a respirator.
- ▶ Ensure adequate ventilation.



⚠ CAUTION

Danger as a result of splintering or spinning material!

Splintering or spinning material can lead to injuries.

- ▶ Use protective gloves.
- ▶ Use safety goggles.



⚠ CAUTION

Risk of injury when driving in piles!

Falling machine or tools can lead to injuries.

- ▶ Use suitable tools.
- ▶ Use a hard hat.
- ▶ Use safety goggles.



⚠ CAUTION

Danger of slipping or falling!

When working on demolition edges, slipping or falling can lead to injuries.

- ▶ Ensure a safe footing.



NOTICE

Improper handling can lead to damage to the machine.

- ▶ Do not pull out the starter cable as far as it will go.
- ▶ Let the starter cable roll in slowly.

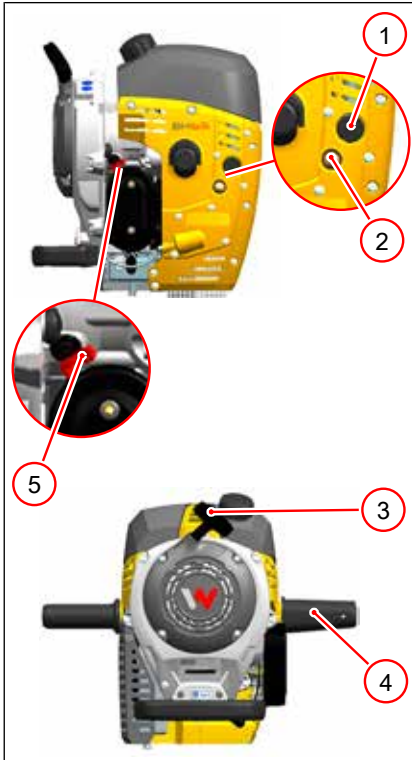

1. Push the throttle grip **4** downwards (full throttle position).
2. Slowly pull out the starter handle **3** to the compression resistance and let it roll in again slowly.
3. Pull out starter handle firmly and evenly, not jerkily (possibly several times).
4. Let the starter handle slowly roll in again.
5. When the first ignition of the engine is heard, deactivate choke **5**.
6. Pull out the starter handle firmly and evenly, not jerking (possibly several times), until the engine starts.
7. Let the starter handle slowly roll in again.
8. Release throttle grip (idle position).
9. Warm up the engine.

8.2 Operating the machine

8.2.1 Processing material



▲ WARNING

Injuries caused by uncontrolled machine operation.

- ▶ Always hold the machine with both hands and take a firm stand.

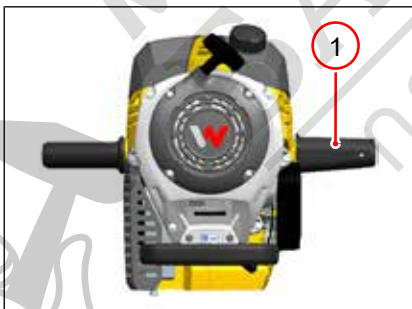

1. Hold the machine with both hands.
2. Apply the tool to the material.
3. Push the throttle grip **1** downwards.
4. Press the machine with both hands against the material to be processed.



Information

Only press so hard that the suspension of the machine can be felt and not the lower stop.

5. Once the material has been machined, lift the machine and move it.



NOTICE

If the material is jammed, proceed as follows:

- ▶ Switch off the engine and let it cool down.
- ▶ Perform tool change (*see Changing tools on page 35*).
- ▶ Start the engine.
- ▶ Use the new tool to clear the jammed tool.

- When the machine is raised and the throttle grip **1** is depressed, the engine continues to run at high speed while the percussion mechanism remains engaged.
- If the tool has no resistance, the percussion mechanism goes to idle and does not strike any more.

8.3 Putting out of operation

8.3.1 Switch off the machine



1. Release throttle grip **3**.
2. Press off push button **1** until the machine has come to a complete standstill.
3. Close fuel cock **2**.
4. Place the machine on the rear of the hood in such a way that it cannot tip over, fall down or slip away. In addition, make sure that there is no contact with combustible materials.



9 Maintenance

9.1 Maintenance plan

Activity	Daily before Operating	Every 20 h	Every 40 h	Once a month	Once a year
Visual check of all components for damage.	•				
Clean the machine: Ventilation slots. • Air filter.	•				
Check fuel: • Fill level of the fuel tank. • Check fuel tank for leaks. • Check pipes for leaks.	•				
Check tool insertion and cutting of the tool - sharpen, forge or replace (have renewed) if necessary.	•				
BH23 Lubricate the machine.		•			
BH55 Lubricate the machine.		•			
BH55rw / BH65 Lubricate the machine.			•		
Clean spark plug. Change if necessary.				•	
Check the tool holder for wear. Have replaced if necessary.*				•	
Have the fuel filter changed.*					•
* Have this work carried out by a service partner.					

9.2 Maintenance work

Working in the workshop

Carry out maintenance work in a workshop on a workbench. This has the following advantages:

- Protection of the machine against dirt from the construction site.
- An even and clean work surface facilitates the work.
- Small parts are easier to keep track of and are not easily lost.

Carrying out preparations

1. Decommissioning the machine.
2. Lean the machine upright against a firm object and secure it against tipping over or place it on its back. Wacker Neuson recommends placing the machine on the transport trolley.
3. Let the machine cool down.



9.2.1 Cleaning the machine

Clean the machine after use.

1. Clean the ventilation slots with a suitable tool. Wacker Neuson recommends cleaning with compressed air.
2. Wipe the housing with a damp and clean cloth.

9.2.2 Add fuel



⚠ WARNING

Fire and explosion hazard due to fuel and fuel vapors!

- ▶ Only refuel in a well-ventilated environment.
- ▶ Do not smoke.
- ▶ Do not refuel near open fire.
- ▶ Switch off the engine and let it cool down before refueling.



⚠ CAUTION

Danger to health from fuel!

- ▶ Only refuel in a well-ventilated environment.
- ▶ Do not inhale fuel vapors.
- ▶ Avoid skin or eye contact with fuel.



NOTICE

- ▶ Unscrew the filler cap slowly so that any excess pressure can slowly escape.



Information

- ▶ Fuel specification [see Technical Data on page 53](#).
- ▶ Fuel mixing table [see Technical Data on page 53](#).



1. Slowly unscrew and remove the filler cap **1**.
2. Refill fuel with a clean funnel
3. Replace filler cap and screw tight.

9.2.3 Checking/cleaning the air filter

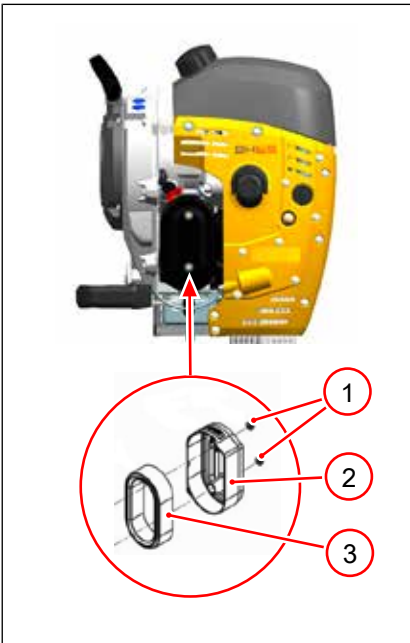

Remove air filter insert

1. Remove dirt in the area of the air filter cover **2**.
2. Unscrew and remove all nuts **1** of the air filter cover .
3. Remove air filter cover.
4. Remove air filter insert **3**.

Check/clean air filter insert

1. Knock out air filter insert **3** and blow out from inside to outside with compressed air.
2. If the dust cannot be removed, replace the air filter insert.



NOTICE

When knocking, make sure that the air filter insert is not damaged.

Install the air filter element

1. Insert air filter insert **3**.
2. Fit air filter cover **2**.
3. Tighten all nuts **1** of the air filter cover.



NOTICE

If the engine is operated without an air filter, there is a risk of faster engine wear!

- ▶ Do not operate the engine without an air filter or air filter cover.

9.2.4 Lubricating the machine



1. Remove dirt in the area of the grease nipple **1**.
2. Place the filled manual grease gun on the grease nipple and actuate it approx. 20 times.
3. Wipe the area of the grease nipple with a damp and clean cloth.



NOTICE

Use only special lubricants for lubrication, *see Technical Data on page 53*.

9.2.5 Checking and changing the spark plug



CAUTION

Risk of burns!

Contact with hot spark plug can cause burns.

- ▶ Only unscrew the spark plug when the engine has cooled down.
- ▶ Use protective gloves.



NOTICE

- ▶ Do not pull the spark plug connector from the spark plug by the ignition cable.

Remove spark plug

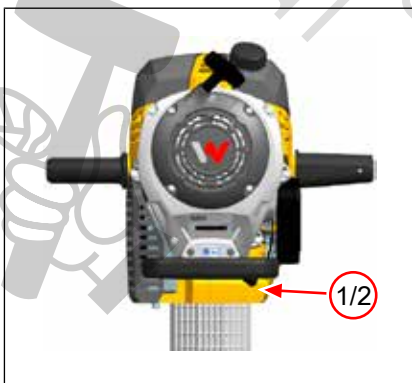

- ✓ The engine is switched off.
 - ✓ The machine has cooled down.
1. Pull out spark plug connector **1**
 2. Remove dirt in spark plug area **2**.
 3. Unscrew spark plug and check.

Checking and cleaning the spark plug

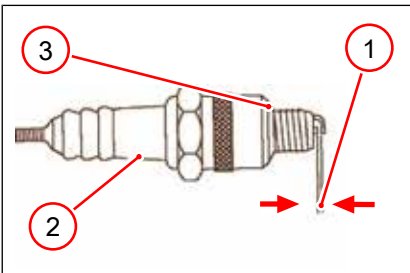

1. Check the isolator **2**.
2. Replace if damaged or heavily soiled.
3. Clean the electrode with a wire brush.
4. Measure electrode spacing **1**, *see Technical Data on page 53*
 ⇒ Correct the distance between the electrodes by bending it.
5. Spark plug and electrode gap **1** *see Technical Data on page 53*.
6. Check spark plug sealing ring **3**.
7. Replace if damaged.

Install spark plug.



NOTICE

Hazard of engine damage!

Too loose or too tightly screwed in spark plug can lead to engine damage.

- ▶ Tighten the spark plugs to the prescribed tightening torque.

1. Tighten spark plug, tightening torque 22 Nm.
2. Plug the spark plug connector onto the spark plug.

9.2.6 Checking the tool holder for wear



NOTICE

Only use a new tool to measure wear on the tool holder.

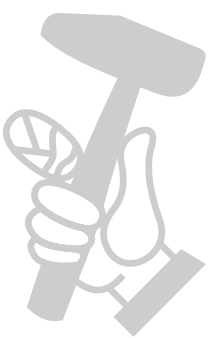

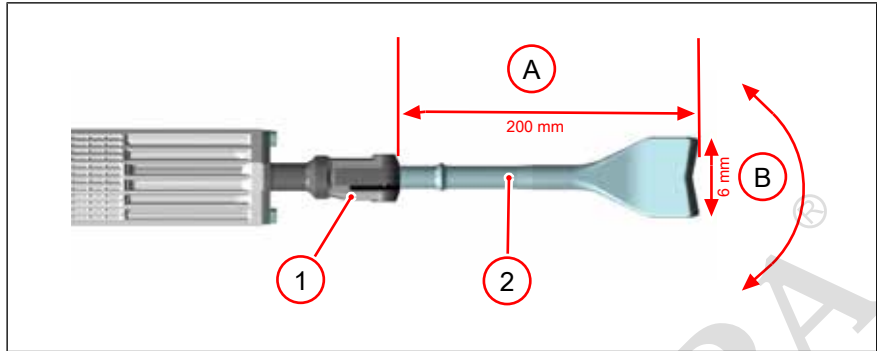

1. Insert new tool **2**.
2. Tool clearance **B** measure 200 mm **A** from the end of tool holder **1**.
3. Move the tool back and forth.
4. Clearance must not exceed 6 mm.
⇒ If the clearance is greater than 6 mm, have the tool holder replaced.

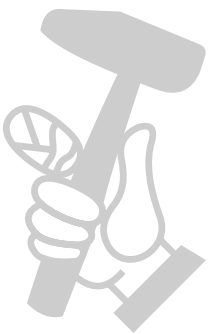

10 Malfunctions

10.1 Troubleshooting

The information in this chapter is intended to help identify faults so that they can be rectified.

If the fault is not remedied with the remedy listed, please contact your Wacker Neuson representative.

Malfunction	Cause	Remedy
Engine does not start.	Fuel cock is closed.	Open the fuel cock.
	Fuel tank is empty.	Refill with fuel.
	Fuel line is clogged.	Have the fuel line cleaned.
	Fuel filter is clogged.	Have the fuel filter changed.*
	Carburetor is clogged.	Clean the carburetor.*
	Air filter is clogged.	Clean the air filter.
	Spark plug connector is defective.	Have the machine repaired.*
	Spark plug is defective.	Replace spark plug.
	Spark plug is loose.	Tighten the spark plug.
	The electrode gap of the spark plug is set incorrectly.	Adjust the electrode gap.
	The connection socket of the remote switch-off is empty.	Connect remote switch-off.
		Plug in the short-circuit plug.
Remote shutdown is not operational.	Check remote shutdown according to the manufacturer's operator's manual.	
The engine stops shortly after starting.	Fuel tank is empty.	Refill with fuel.
	Fuel filter is clogged.	Have the fuel filter changed.*
	The air filter is soiled.	Clean or replace the air filter.
Engine does not work.	The air filter is soiled.	Clean or replace the air filter.
Reverse starter defective.	Starter cable jammed.	Change the starter cable.
	Starter cable is broken.	
* Have this work performed by Wacker Neuson Service.		

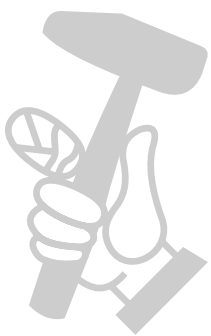



11 Storage

11.1 Carrying out preparations

- ✓ Switch off the engine.
- 1. Remove tool.
- 2. Lean the machine upright against a solid object and secure against tipping over. Wacker Neuson recommends hanging the machine on the transport trolley.
- 3. Let the machine cool down.

11.2 Emptying the fuel system

During prolonged storage, the volatile components of the fuel escape. This changes the mixing ratio. Empty fuel system before prolonged storage.

1. Remove dirt in the area of the filler cap.
2. Unscrew and remove the filler cap.
3. Pump fuel into a suitable container or tank, e.g. with a suction lift pump.
4. Replace filler cap and screw tight.
5. Start the engine and let it run at idle until the fuel in the carburetor is used up and the engine stops.

11.3 Storing the machine

1. Clean the machine.
2. Lubricate areas prone to rust, such as tool holders and handles.
3. Store the machine in a dry place.
4. Observe storage temperature range, [see Technical Data on page 53](#).

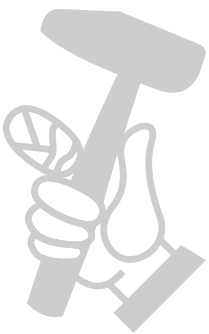

12 Accessories

12.1 Transport trolley

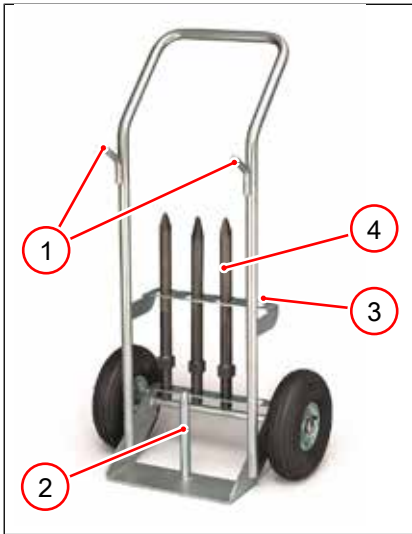

- 1 Suspension device
- 2 Guide rod
- 3 Tool mount
- 4 Tool

12.1.1 Designated use

The transport trolley may only be used to transport Wacker Neuson hammers and the required tools.

Unintended use

The transport trolley must not be used for the following purposes:

- Transporting people.
- Transport other machinery than Wacker Neuson hammers.
- The transport trolley must not be attached to vehicles.

12.1.2 Place the machine on the transport carriage.



⚠ CAUTION

Shifting of the center of gravity of the transport trolley!

Injuries or material damage caused by the transport trolley falling over or rolling away when picking up the machine.

- ▶ Park the transport trolley on level ground.
- ▶ Secure the transport trolley against rolling away and tilting.
- ▶ Use protective gloves.

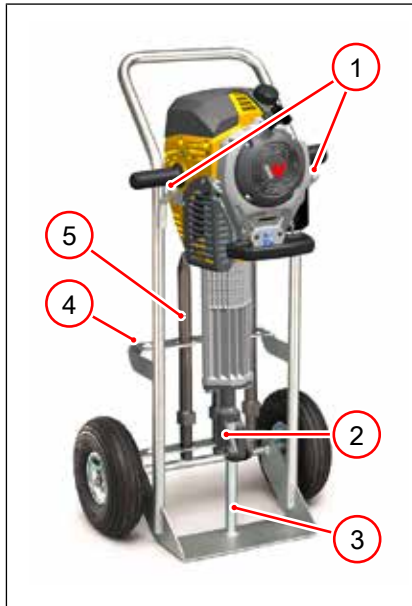

✓ Switch off the machine.

1. Remove tool **5** from the tool holder **2**.
2. Clean the guide rod **3** of the transport trolley.
3. Attach the machine with the tool holder to the guide rod and place it on the suspension device **1** of the transport trolley.
4. Insert tool into the tool holder **4**.

МАГАЗИН МАЙСТОРА
БАШ
ПРОФЕСИОНАЛНИ РЕШЕНИЯ

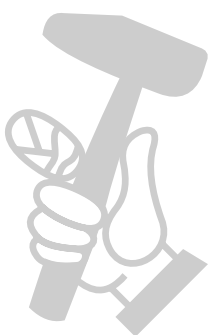

13 Technical Data

13.1 General instructions



Information

For system technical reasons, empty columns can be displayed in the technical data, and numbers and letters that written in superscript or subscript may be displayed incorrectly, e.g:

- ▶ Sound power level L_{WA} instead of L_{WA}
- ▶ Sound pressure level L_{pA} instead of L_{pA}
- ▶ Vibration total value a_{hv} instead of a_{hv}
- ▶ Carbon dioxide CO₂ instead of CO₂
- ▶ Unit m/s² instead of m/s²

13.2 Noise and vibration data

The noise and vibration data listed have been determined in accordance with the following guidelines for the typical machine operating conditions / special test conditions and using harmonized standards:

- Machinery Directive 2006/42/EC
- Noise Emission Directive 2000/14/EC

During operational use, values may differ depending on the prevailing operating conditions.

13.2.1 Noise information

Sound pressure level at operator station

- L_{pA} was determined according to EN ISO 11203.

Guaranteed sound power level

- L_{WA} was determined according to 2000/14/EG, EN ISO 3744.

13.2.2 Vibration indication hand-arm vibration (HAV)

Weighted vibration total value

- a_{hv} was determined according to EN ISO 28927-10.

13.3 BH23

Type	BH23 27x80 CN	
Material number	5100060159	
Number of strokes [1/min]	1.300	
Single stroke energy [J]	55	
Length (without tool) [mm]	777	
Width [mm]	492	
Depth [mm]	346	



Type	BH23 27x80 CN	
Weight [kg]	22,8	
Tool holder	Ø 27x80	
Rated output [kW]	1,6	
Rated speed [1/min]	4.250	
Special lubricants	Gadus S3 V220C 2	
Fuel consumption [l/h]	0,9	
Tank volume [l]	1,8	
Operating temperature range [°C]	-10 - +40	
Storage temperature range [°C]	-30 - +50	
Sound pressure level LpA [dB(A)]	101	
Sound power level Lwa measured [dB(A)]	106	
Sound power level Lwa guaranteed [dB(A)]	109	
Vibration total value ahv [m/s ²]	8,3	
Measurement uncertainty of the total vibration value ahv [m/s ²]	3,0	

* The actual operating speed depends on numerous operating parameters and may differ from the rated speed.

13.4 BH55

Type	BH55 25x108	BH55 27x80	BH55 28x160
Material number	5100047104	5100047063	5100047105
Number of strokes [1/min]	1.300	1.300	1.300
Single stroke energy [J]	55	55	55
Length (without tool) [mm]	791	777	833
Width [mm]	492	492	492
Depth [mm]	346	346	346
Weight [kg]	22,7	22,8	23,8
Tool holder	Hex 25x108	Ø 27x80	Hex 28x160
Rated output [kW]	1,6	1,6	1,6
Rated speed [1/min]	4.250	4.250	4.250
Special lubricants	Gadus S3 V220C 2	Gadus S3 V220C 2	Gadus S3 V220C 2
Fuel consumption [l/h]	0,9	0,9	0,9
Tank volume [l]	1,8	1,8	1,8
Operating temperature range [°C]	-10 - +40	-10 - +40	-10 - +40
Storage temperature range [°C]	-30 - +50	-30 - +50	-30 - +50
Sound pressure level LpA [dB(A)]	101	101	101
Sound power level Lwa measured [dB(A)]	107	107	107
Sound power level Lwa guaranteed [dB(A)]	109	109	109

Type	BH55 25x108	BH55 27x80	BH55 28x160
Vibration total value ahv [m/s ²]	8,3	8,3	8,3
Measurement uncertainty of the total vibration value ahv [m/s ²]	3,0	3,0	3,0

* The actual operating speed depends on numerous operating parameters and may differ from the rated speed.

13.5 BH55rw

Type	BH55rw 27x80	BH55rw rs 27x80
Material number	5100047100	5100047103
Number of strokes [1/min]	1.300	1.300
Single stroke energy [J]	55	55
Length (without tool) [mm]	842	842
Width [mm]	492	492
Depth [mm]	346	346
Weight [kg]	24,2	24,2
Tool holder	Ø 27x80	Ø 27x80
Rated output [kW]	1,6	1,6
Rated speed [1/min]	4.500	4.500
Special lubricants	Gadus S3 V220C 2	Gadus S3 V220C 2
Fuel consumption [l/h]	0,9	0,9
Tank volume [l]	1,8	1,8
Operating temperature range [°C]	-10 - +40	-10 - +40
Storage temperature range [°C]	-30 - +50	-30 - +50
Sound pressure level LpA [dB(A)]	101	101
Sound power level Lwa measured [dB(A)]	106	106
Sound power level Lwa guaranteed [dB(A)]	109	109
Vibration total value ahv [m/s ²]	4,5	4,5
Measurement uncertainty of the total vibration value ahv [m/s ²]	3,0	3,0

* The actual operating speed depends on numerous operating parameters and may differ from the rated speed.

Type	BH55rw 28x160	BH55rw 32x160
Material number	5100047101	5100047102
Number of strokes [1/min]	1.350	1.300
Single stroke energy [J]	55	55
Length (without tool) [mm]	898	898
Width [mm]	492	492
Depth [mm]	346	346
Weight [kg]	25,2	25,1
Tool holder	Hex 28x160	Hex 32x160
Rated output [kW]	1,6	1,6
Rated speed [1/min]	4.500	4.500



Type	BH55rw 28x160	BH55rw 32x160
Special lubricants	Gadus S3 V220C 2	Gadus S3 V220C 2
Fuel consumption [l/h]	0,9	0,9
Tank volume [l]	1,8	1,8
Operating temperature range [°C]	-10 - +40	-10 - +40
Storage temperature range [°C]	-30 - +50	-30 - +50
Sound pressure level LpA [dB(A)]	101	101
Sound power level Lwa measured [dB(A)]	106	106
Sound power level Lwa guaranteed [dB(A)]	109	109
Vibration total value ahv [m/s ²]	4,5	4,5
Measurement uncertainty of the total vibration value ahv [m/s ²]	3,0	3,0

* The actual operating speed depends on numerous operating parameters and may differ from the rated speed.

13.6 BH65

Type	BH65 25x108	BH65 27x80
Material number	5100047107	5100047106
Number of strokes [1/min]	1.250	1.300
Single stroke energy [J]	65	65
Length (without tool) [mm]	858	858
Width [mm]	492	492
Depth [mm]	346	346
Weight [kg]	24,1	24,2
Tool holder	Hex 25x108	Ø 27x80
Rated output [kW]	1,7	1,7
Rated speed [1/min]	4.100	4.100
Special lubricants	Gadus S3 V220C 2	Gadus S3 V220C 2
Fuel consumption [l/h]	0,9	0,9
Tank volume [l]	1,8	1,8
Operating temperature range [°C]	-10 - +40	-10 - +40
Storage temperature range [°C]	-30 - +50	-30 - +50
Sound pressure level LpA [dB(A)]	101	101
Sound power level Lwa measured [dB(A)]	106	106
Sound power level Lwa guaranteed [dB(A)]	109	109
Vibration total value ahv [m/s ²]	4,6	4,6
Measurement uncertainty of the total vibration value ahv [m/s ²]	3,0	3,0

* The actual operating speed depends on numerous operating parameters and may differ from the rated speed.

Type	BH65 28x160	BH65 32x160
Material number	5100047068	5100047069
Number of strokes [1/min]	1.250	1.250
Single stroke energy [J]	65	65

Type	BH65 28x160	BH65 32x160
Length (without tool) [mm]	905	905
Width [mm]	492	492
Depth [mm]	346	346
Weight [kg]	25,2	25,1
Tool holder	Hex 28x160	Hex 32x160
Rated output [kW]	1,7	1,7
Rated speed [1/min]	4.100	4.100
Special lubricants	Gadus S3 V220C 2	Gadus S3 V220C 2
Fuel consumption [l/h]	0,9	0,9
Tank volume [l]	1,8	1,8
Operating temperature range [°C]	-10 - +40	-10 - +40
Storage temperature range [°C]	-30 - +50	-30 - +50
Sound pressure level LpA [dB(A)]	101	101
Sound power level Lwa measured [dB(A)]	106	106
Sound power level Lwa guaranteed [dB(A)]	109	109
Vibration total value ahv [m/s ²]	4,6	4,6
Measurement uncertainty of the total vibration value ahv [m/s ²]	3,0	3,0

* The actual operating speed depends on numerous operating parameters and may differ from the rated speed.

Type	BH65 28x160 Loxam	
Material number	5100051587	
Number of strokes [1/min]	1.250	
Single stroke energy [J]	65	
Length (without tool) [mm]	905	
Width [mm]	492	
Depth [mm]	346	
Weight [kg]	25.2	
Tool holder	Hex 28x160	
Rated output [kW]	1,7	
Rated speed [1/min]	4.100	
Special lubricants	Gadus S3 V220C 2	
Fuel consumption [l/h]	0,9	
Tank volume [l]	1,8	
Operating temperature range [°C]	-10 - +40	
Storage temperature range [°C]	-30 - +50	
Sound pressure level LpA [dB(A)]	101	
Sound power level Lwa measured [dB(A)]	106	
Sound power level Lwa guaranteed [dB(A)]	109	
Vibration total value ahv [m/s ²]	4,6	
Measurement uncertainty of the total vibration value ahv [m/s ²]	3,0	

* The actual operating speed depends on numerous operating parameters and may differ from the rated speed.



13.7 Combustion engine WM80c

Engine manufacturer	Wacker Neuson
Material number engine	5100045178
Engine type	WM80c
Combustion processes	two-stroke
Cooling	Air
Cylinder	1
Cubic capacity [cm ³]	80
Fuel type	Oil/gasoline mixture Oil/alkylate fuel mixture
Mixture preparation	Carburetor
Fuel mixing ratio	1:50 (1:100)
Oil specification	JASO FD, JASO FC, ISO-L-EGD, ISO-L-EGC
Exhaust-emission level	EU level V
CO ₂ emission [g/kWh]	1194
Exhaust gas aftertreatment	Oxidation catalyst
Upper idling speed [1/min]	2.000
Spark plug type	Bosch WR7AC, Champion RL86C
Electrode gap [mm]	0,5
Starter type	Reverse starter
* Determined value of the CO ₂ emission during engine certification without consideration of the applications on the machine.	

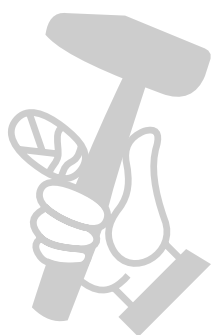

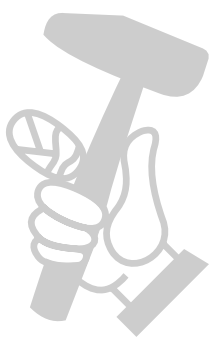

МАГАЗИН
БАШ МАЙСТОРА[®]
ПРОФЕСИОНАЛНИ РЕШЕНИЯ



**WACKER
NEUSON**
all it takes!

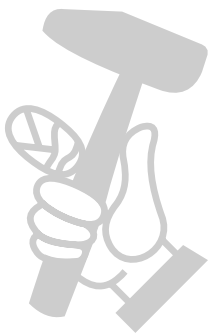

МАГАЗИН
БАШ МАЙСТОРА[®]
ПРОФЕСИОНАЛНИ РЕШЕНИЯ

**Wacker Neuson Produktion GmbH &
Co. KG**

Wackerstraße 6
D-85084 Reichertshofen

Tel.: +49 8453 340-0
EMail: service-LE@wackerneuson.com
www.wackerneuson.com

Material number: 5100056213
Language: [us]