

ALFRA ROTABEST® 80 B



Rittal Automation Systems

- DE METALLKERNBOHRMASCHINE
- EN METAL CORE DRILLING MACHINE
- FR PERCEUSE À SOCLE MAGNÉTIQUE
- ES MÁQUINA TALADRADORA DE NÚCLEO METÁLICO
- IT CAROTATRICE PER METALLI



#18481

BETRIEBSANLEITUNG
OPERATING INSTRUCTIONS | MANUEL D'UTILISATION | MANUAL DE INSTRUCCIONES | ISTRUZIONI PER L'USO

Dear customer,

Thank you for purchasing an ALFRA product. Be sure to read these operation instructions closely before using your device for the first time and keep them for later reference.

SAFETY INSTRUCTIONS

Danger can occur when working with this machine due to improper handling and/or poor maintenance, which may lead to the destruction of the device and to severe physical injuries. Observe all safety instructions of this operating manual and contact our Service Team if you have any questions.

**Always...**

- activate the magnet on metallic, ferromagnetic materials
- use the whole magnetic surface for working
- work on plane surfaces
- clean the magnetic surface and keep it clear of dirt, swarf and welding sputter
- set the core drilling machine down gently to prevent damage to the magnetic surface
- secure yourself with a safety belt when drilling on walls or ceilings
- check connection cables for damage
- make sure the mains voltage matches the machine
- follow the instructions in these operation instructions
- familiarise new users with the safe use of the machine
- wear safety goggles and ear protection during work
- use safety guard if supplied
- observe local, country-specific guidelines
- store and use in a dry place

**Never...**

- work on round or curved objects
- drill several work pieces on top of one another
- modify the core drilling machine or remove signs
- use the core drilling machine when damaged or when parts are missing
- strain or damage the underside of the magnet through heavy impact or blows
- use the core drilling machine without having been properly instructed
- operate the machine without having read and understood the complete operating manual
- use the core drilling machine to support, lift or transport persons or loads
- carry out electric welding work on the work piece at the same time as using the core drilling machine
- store or operate the core drilling machine at temperatures above 50°C (122°F)
- leave the machine hanging unsupervised
- allow the machine to come into contact with corrosive materials



People with cardiac pacemakers or other medical appliances may only use this machine following approval by their physician.



Never touch rotating parts! Keep hands and fingers away from the work area while the motor is running! Failure to do so can result in severe injuries!

SPECIFIED CONDITIONS OF USE

This machine is destined to cut material with magnetisable surface with core cutters and twist drills in sheltered environment for commercial use in industry and craft. The device is suitable for drilling vertical, horizontal and overhead.

TECHNICAL DATA

Prod.-No. and description	18481 Rotabest RB 80B	
Input	1800 Watt	
On-load speed	110/175/245/385 rpm	
Tool holder	MT3	
Coolant supply	internal	
Voltage: (See nameplate)	230 V 50/60 Hz	110 V 50/60 Hz
Magnetic adhesion	13000 N	2900 lbs
Tool force (on 10 mm steel)	4000 N	950 lbs
Boring Ø max. in steel - Core cutter: - Twist drills:	12 - 80 mm up to Ø 30mm DIN 338	15/32" - 3"
Min. material thickness	10 mm	
Stroke	190 mm + 100 mm adjustable height on slide	7.5" + 3.9" adjustable height on slide
Size of magnetic base	92 x 220 mm	3.6" x 8.7"
Weight	19,5 kg	43 lbs
Noise emission	92 dB(A) @ 300 mm distance from the motor	92 dB(A) @ 12" distance from the motor the motor
Vibration on the handle	AC=3,5 mm/s ² and VC=3,2 mm/s	
Further functions	Motor emergency stop Magnetic field sensor	
Protection class	1	

AVAILABLE ACCESSORIES

Available Accessories	Prod.-No.
Transport case	189412037
Coolant unit	189412029
Coolant spray ALFRA BIO 4000	21040
MT3 Tool holder	18025
Safety belt	189490501
Allen key 2,5 mm	DIN911-2,5
Allen key 4,0 mm	DIN911-4,0
Allen key 6,0 mm	DIN911-6,0
Swarf remover	189480022

DESCRIPTION

The Magnetic Core Drilling Machine can be fixed with a switchable electromagnet on ferromagnetic work pieces. The electromagnet (C) and the motor (A) can be switched on and off with the large buttons of the control panel (E). A self-adjusting dovetail guide on which the motor is mounted can be adjusted in height with the star handle (F). On the back of the machine is the nameplate including the serial number.

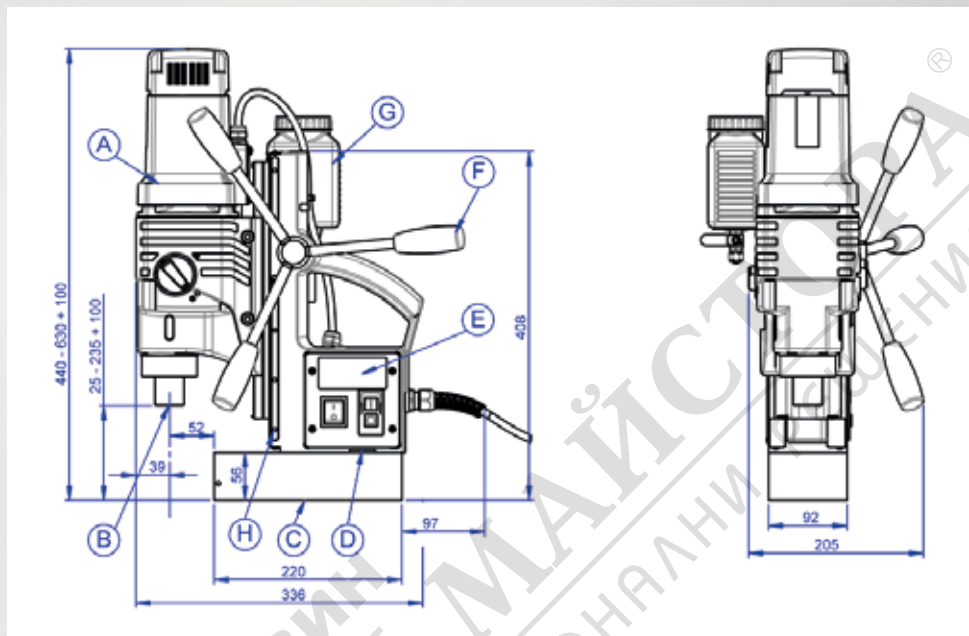

- A) Motor
- B) Weldon-Arbor
- C) Magnetic base
- D) Recess for safety belt
- E) Control panel
- F) Star handle
- G) Coolant unit
- H) Adjustable screws to adjust the slide

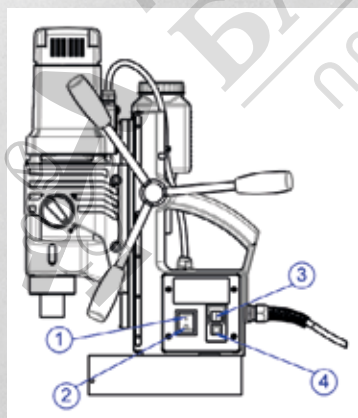

- 1 – Magnet ON
- 2 – Magnet OFF
- 3 – Motor ON
- 4 – Motor OFF

COMMISSIONING

Your package contains a fully assembled metal core drilling machine and detailed operating instructions. Upon receiving your delivery, please check its contents for any transport damage and that you received everything you ordered. Please instantly contact the manufacturer if you encounter any problems.



Always read the operation manual before using the device for the first time!

1. First of all, check the cables and connectors for damages.
2. Plug the safety switch connector into a fused mains socket.
3. Before starting the core drilling machine motor, be sure to press the RESET button to activate the safety switch. Repeat this step every time you pull the mains plug and every time the safety switch triggers.



4. Activate the solenoid by pressing the associated switch (Solenoid) to ensure that the drill rig reliably adheres to the workpiece.



- If you are working on non-magnetic materials, please use the ROTABEST Vacubest vacuum equipment (part no. 18150).
5. Secure Rotabest with a strap when holding the machine vertically up against the wall or ceiling. During these applications, best practice is to cool the drill bit with a spray (e.g. ALFRA 4000, part no. 21040).
 6. Press the green button (Motor) to switch on the drive motor.
 7. Repeat the above step to switch the motor off: First of all, press the red button (Motor) to switch off the motor, then press the Solenoid button to deactivate the solenoid.

Do not use the safety switch as an On/Off switch!



WORKING WITH ANNULAR CUTTERS

- Push centring and ejecting pin through head of annular cutter.
- Core drills with Weldon shank are tightened with clamping screws (DIN 913) on both clamping surfaces.
- First place annular cutter with centring and ejecting pin on a marked centre or marking.
- Set the cutter and spot-drill, until the entire cut edge is formed as a circle.
- During the drilling process, the cutter should be cooled permanently. Optimal cooling is possible by internal cooling with our coolant unit.
- During the drilling process, do not stop the motor. After the process, cutter draws back with running motor.
- Remove chips and core after each drilling.

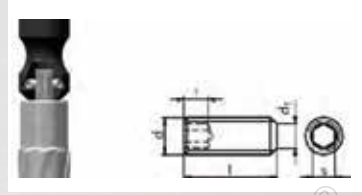

Remove chips with Chip-Remover. Do not touch with bare hands. Danger of injury!

WORKING WITH TWIST DRILLS

- The drill chuck with Weldon shank is only to be used with twist drills up to a diameter of 13 mm.
- Insert drill chuck with adaptor in the drill spindle.
- Insert twist drill in drill chuck and tighten.

MAINTENANCE AND INSPECTION

The user is obliged to maintain and service the core drilling machine in compliance with the specifications in the operating manual and according to the country-specific standards and regulations.

The maintenance intervals are classified according to the frequency with which the maintenance should be carried out.



Always disconnect the machine from the mains before any maintenance operation and repairs, otherwise there is a risk of injury due to unintentional machine switch-on.

Before every use...

- inspect the core drilling machine and underside of the magnet for visible signs of damage
- clean the surface of the work piece and the underside of the magnet
- check the correct, firm fit of the core drill
- check connection cables for damage

Weekly...

- use dry compressed air to blow the motor compartment out from the outside

Monthly...

- check the markings and labelling on the core drilling machine for legibility and damage.
Replace them if necessary
- clean all the sliding surfaces regularly, re-lubricate them and set the pre-tension of the slide

Annually...

- replace the gear oil or gear grease
- replace the carbon brushes after about 250 operating hours

Maintenance, testing and repair work may only be carried out by qualified electricians according to the regulations valid in the respective country.



**Only use original ALFRA spare parts.
View our detailed spare parts list at the end of this operating manual.**

DECLARATION OF CONFORMITY

Manufacturer:	Alfra GmbH 2. Industriestr. 10 D-68766 Hockenheim Germany
Official authorised entity for compilation of the relevant technical documentation:	Dr. Marc Fleckenstein, CEO, Alfra GmbH 2. Industriestraße 10 D-68766 Hockenheim Germany
Product:	Angular Metal Core Drilling Machine Rotabest 8o B 18481
Declaration of conformity:	

We hereby declare that the aforementioned product complies with all relevant provisions of the Machinery Directive 2006/42/EC. The protection objectives of the Low Voltage Directive 2014/35/EU are complied with according to Appendix No. 1.5.1 of the Machinery Directive.

The aforementioned product thereby fulfils the requirements of the following relevant directives:

- Machinery Directive 2006/42/EC
- EMC Directive 2014/30/EU
- RoHS Directive 2011/65/EU

The following harmonised standards have been applied:

- EN ISO 12100:2011-03; Safety of machinery - General principles for design - Risk assessment and risk reduction (ISO 12100:2010); German version EN ISO 12100:2010.
- DIN EN 62841-1:2016-07; VDE 0740-1:2016-07 - Electric motor-operated hand-held tools, transportable tools, lawn machinery and garden machinery - Safety - Part 1: General Requirements
- DIN EN 62841-1:2018-08; VDE 0740-2.1:2018-08 - Electric motor-operated hand-held tools, transportable tools, lawn machinery and garden machinery - Safety - Part 2-1: Particular requirements for hand-held drills and impact drills
- DIN EN 60204-1:2019-06; VDE 0113-1:2019-06 - Safety of machinery - Electrical equipment of machinery - Part 1: General Requirements
- DIN EN 60034-5:2021-05; VDE 0530-5:2021-05 - Rotating electrical machinery - Part 5: Types and degrees of protection based on the overall design of rotating electrical machinery (IP code) - Classification
- DIN EN IEC 63000:2019-05; VDE 0042-12:2019-05 - Technical documentation regarding the assessment of electrical devices and electronic devices with regard to the restriction of hazardous substances (IEC 63000:2016); German version EN IEC 63000:2018
- DIN EN 61000-3-2:2015-03; VDE 0838-2:2015-03 - Electromagnetic compatibility (EMC) - Part 3-2 Limiting values - Limiting values for harmonic currents
- DIN EN 61000-3-3:2020-07; VDE 0838-3:2020-07 - Electromagnetic compatibility (EMC) - Part 3-3 Limiting values - Limitation of voltage alterations, voltage fluctuations and flicker in public low-voltage supply systems for devices with a rated current ≤ 16 A per conductor which are not subjected to a special connection condition
- DIN EN 55014-1:2018-08; VDE 0875-14-1 - Electromagnetic compatibility - Requirements for household appliances and devices, electric tools and similar electrical devices - Part 1: Interference immission

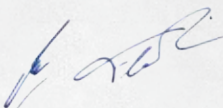

Dr. Marc Fleckenstein
(CEO)

Hockenheim, 01.09.2021