

↑ Domestic use

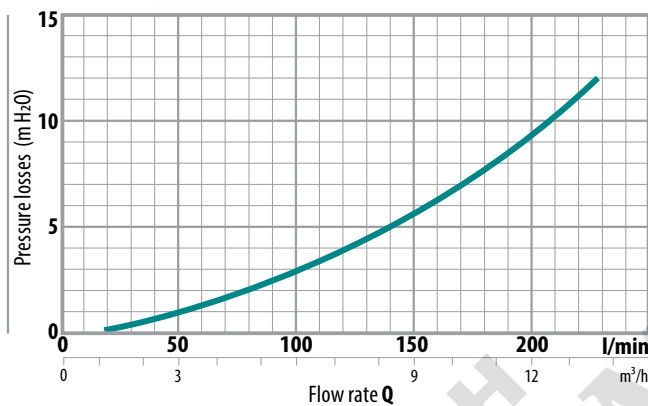

### PRESSURE LOSSES



### MAXIMUM DELIVERY HEIGHT

- 2.2 bar version ● = 18 m
- 1.5 bar version ● = 11 m
- 0.8 bar version ● = 5 m

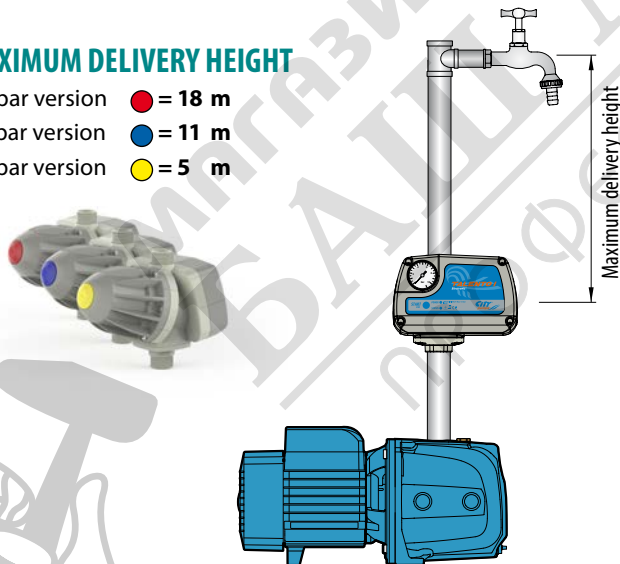

### DIMENSIONS AND WEIGHT

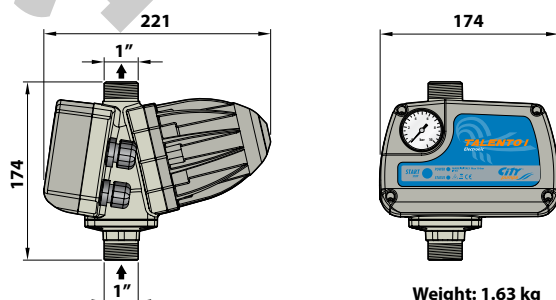

### PERFORMANCE RANGE

- Max flow rate: **200 l/min** (12 m<sup>3</sup>/h)
- Working pressure: **10 bar**
- Restarting pressure: **1.5 bar** ●

### APPLICATION LIMITS

- Maximum liquid temperature **+65 °C**
- Ambient temperature up to **+40 °C**
- Burst pressure **> 40 bar**
- Protection: **IP 65**
- Power: – **0.75 kW (1 HP)** TALENTO-1  
– **1.5 kW (2 HP)** TALENTO-2
- Voltage: **230 V**
- Frequency: **50/60 Hz**
- Max current: – **10 A** TALENTO-1  
– **16 A** TALENTO-2
- Flow rate: **12 m<sup>3</sup>/h**

### CONSTRUCTION AND SAFETY STANDARDS

- Resinated and easily replaced electronic card for complete protection from humidity, fitted in the case with an IP 65 protection.
- The electronic card inside TALENTO has undergone the strictest EMC tests of electromagnetic compatibility.

### INSTALLATION AND USE

The TALENTO series consists of electronic devices designed to start (when a tap is turned on) and stop (when a tap is turned off) single-phase pumps.

A microprocessor protects the pump from dry running, and allows the pump to be restarted either automatically or manually. It also prevents the pump from starting too often when small leaks are present within an installation.

### OPTIONS AVAILABLE ON REQUEST

- TALENTO-1 version with restarting pressure **0.8 bar** ●
- TALENTO-2 version with restarting pressure **2.2 bar** ●
- Version with 1" NPT
- Version with cable and Schuko plug and socket
- Version with pressure gauge

### STARTING PRESSURE

There are three different models available, each with a different starting pressure and easily identified by the coloured cap positioned at the rear of the TALENTO, for installations requiring delivery at various heights.

### ACCESSORIES

