

DIN 933 / ISO 4017 sim. UNI 5739

Vite a testa esagonale interamente filettata

Hexagon screw

Disponibile  A2

Available  A4

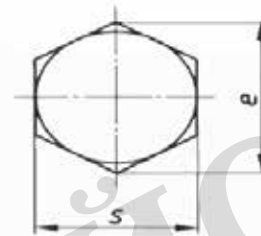
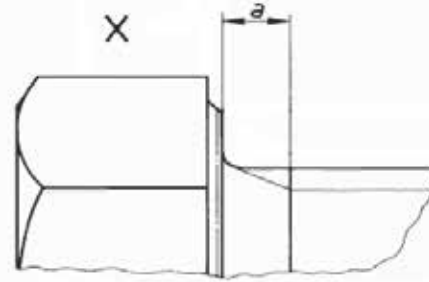
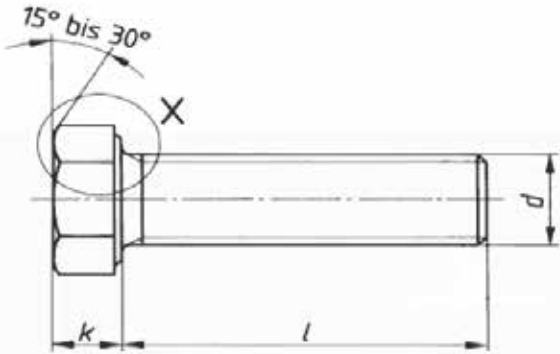

Thread size		M3	M4	M5	M6	M8	M10*	M12*	(M14*)	M16	(M18)	M20	(M22*)	M24	(M27)	M30	(M33)	M36	
passo del filetto / pitch of the thread.		0,5	0,7	0,8	1	1,25	1,5	1,75	2	2	2,5	2,5	2,5	3	3	3,5	3,5	4	
a	max.	1,5	2,1	2,4	3	3,75	4,5	5,25	6	6	7,5	7,5	7,5	9	9	10,5	10,5	12	
	min. Product Grade	A	6,01	7,66	8,79	11,05	14,38	18,9	21,1	24,49	26,75	30,14	33,53	35,72	39,98	-----	-----	-----	-----
e	B	-----	-----	-----	-----	-----	-----	-----	-----	26,17	29,56	32,95	35,03	39,55	45,2	50,85	55,37	60,79	
	Nominal Size	2	2,8	3,5	4	5,3	6,4	7,5	8,8	10	11,5	12,5	14	15	17	18,7	21	22,5	
k	Product Grade	A	min.	1,88	2,68	3,35	3,85	5,15	6,22	7,32	8,62	9,82	11,28	12,28	13,78	14,78	-----	-----	-----
			max.	2,12	2,92	3,65	4,15	5,45	6,56	7,68	8,98	10,18	11,72	12,72	14,22	15,22	-----	-----	-----
	B	min.	-----	2,6	3,26	3,76	5,06	6,11	7,21	8,51	9,71	11,15	12,15	13,65	14,65	16,65	18,28	20,58	22,08
		max.	-----	3	3,74	4,24	5,54	6,69	7,79	9,09	10,29	11,85	12,85	14,35	15,35	17,35	19,12	21,42	22,92
max. = Nominal size		5,5	7	8	10	13	17	19	22	24	27	30	32	36	41	46	50	55	
s	min. Product Grade	A	5,32	6,78	7,78	9,78	12,73	16,73	18,67	21,67	23,67	26,67	29,67	31,61	35,38	-----	-----	-----	-----
	B	-----	6,64	7,64	9,64	12,57	16,57	18,48	21,16	23,16	26,15	29,16	31	35	40	45	49	53,8	

La dimensioni tra parentesi sono sconsigliate
 The size in brackets should be avoided if possible

* tranne i diametri M10-M12-M14 e M22, compatibili solo con la versione DIN, tutte le altre misure sono compatibili con entrambe le versioni (DIN e ISO)

* except the diameters M10-M12-M14 and M22, compatible only with the DIN version, all other sizes are compatible with both versions (DIN and ISO)

l/d	M3	M4	M5	M6	M8	M10*	M12*	(M14*)	M16	(M18)	M20	(M22*)	M24	(M27)	M30	(M33)	M36
5	3x5	4x5															
6	3x6	4x6	5x6	6x6													
8	3x8	4x8	5x8	6x8	8x8												
10	3x10	4x10	5x10	6x10	8x10	10x10											
12	3x12	4x12	5x12	6x12	8x12	10x12											
(14)	3x14	4x14	5x14	6x14	8x14	10x14											
16	3x16	4x16	5x16	6x16	8x16	10x16	12x16										
(18)	3x18	4x18	5x18	6x18	8x18	10x18	12x18										
20	3x20	4x20	5x20	6x20	8x20	10x20	12x20	14x20	16x20								
(22)	3x22	4x22	5x22	6x22	8x22	10x22	12x22	14x22	16x22								
25	3x25	4x25	5x25	6x25	8x25	10x25	12x25	14x25	16x25								
(28)	3x28	4x28	5x28	6x28	8x28	10x28	12x28	14x28	16x28								
30	3x30	4x30	5x30	6x30	8x30	10x30	12x30	14x30	16x30	18x30	20x30						
35	3x35	4x35	5x35	6x35	8x35	10x35	12x35	14x35	16x35	18x35	20x35						
40	3x40	4x40	5x40	6x40	8x40	10x40	12x40	14x40	16x40	18x40	20x40	22x40	24x40				
45	3x45	4x45	5x45	6x45	8x45	10x45	12x45	14x45	16x45	18x45	20x45	22x45	24x45				
50	3x50	4x50	5x50	6x50	8x50	10x50	12x50	14x50	16x50	18x50	20x50	22x50	24x50	27x50	30x50		
55		4x55	5x55	6x55	8x55	10x55	12x55	14x55	16x55	18x55	20x55	22x55	24x55	27x55	30x55		
60		4x60	5x60	6x60	8x60	10x60	12x60	14x60	16x60	18x60	20x60	22x60	24x60	27x60	30x60		

La dimensioni tra parentesi sono sconsigliate
The size in brackets should be avoided if possible

Le misure commerciali sono quelle in nero
Black sizes = commercial sizes

Le misure al di sopra della linea tratteggiata sono grado di prodotto A, mentre le misure al di sotto della linea tratteggiata sono di grado B
Product grade A has been given above, product grade B below the stepped line

l/d	M3	M4	M5	M6	M8	M10*	M12*	(M14*)	M16	(M18)	M20	(M22*)	M24	(M27)	M30	(M33)	M36
65		4x65	5x65	6x65	8x65	10x65	12x65	14x65	16x65	18x65	20x65	22x65	24x65	27x65	30x65		
70		4x70	5x70	6x70	8x70	10x70	12x70	14x70	16x70	18x70	20x70	22x70	24x70	27x70	30x70	33x70	
(75)			5x75	6x75	8x75	10x75	12x75	14x75	16x75	18x75	20x75	22x75	24x75	27x75	30x75	33x75	
80			5x80	6x80	8x80	10x80	12x80	14x80	16x80	18x80	20x80	22x80	24x80	27x80	30x80	33x80	36x80
(85)				6x85	8x85	10x85	12x85	14x85	16x85	18x85	20x85	22x85	24x85	27x85	30x85	33x85	36x85
90				6x90	8x90	10x90	12x90	14x90	16x90	18x90	20x90	22x90	24x90	27x90	30x90	33x90	36x90
(95)				6x95	8x95	10x95	12x95	14x95	16x95	18x95	20x95	22x95	24x95	27x95	30x95	33x95	36x95
100				6x100	8x100	10x100	12x100	14x100	16x100	18x100	20x100	22x100	24x100	27x100	30x100	33x100	36x100
110				6x110	8x110	10x110	12x110	14x110	16x110	18x110	20x110	22x110	24x110	27x110	30x110	33x110	36x110
120				6x120	8x120	10x120	12x120	14x120	16x120	18x120	20x120	22x120	24x120	27x120	30x120	33x120	36x120
130					8x130	10x130	12x130	14x130	16x130	18x130	20x130	22x130	24x130	27x130	30x130	33x130	36x130
140					8x140	10x140	12x140	14x140	16x140	18x140	20x140	22x140	24x140	27x140	30x140	33x140	36x140
150					8x150	10x150	12x150	14x150	16x150	18x150	20x150		24x150	27x150	30x150	33x150	36x150
160					8x160	10x160	12x160		16x160	18x160	20x160		24x160				36x160
(170)					8x170	10x170	12x170		16x170	18x170	20x170		24x170				36x170
180					8x180	10x180	12x180		16x180	18x180	20x180		24x180				36x180
(190)					8x190	10x190	12x190		16x190	18x190	20x190		24x190				36x190
200					8x200	10x200	12x200		16x200	18x200	20x200		24x200				36x200

La dimensioni tra parentesi sono sconsigliate
The size in brackets should be avoided if possible

Le misure commerciali sono quelle in nero
Black sizes = commercial sizes

Le misure al di sopra della linea tratteggiata sono grado di prodotto A, mentre le misure al di sotto della linea tratteggiata sono di grado B
Product grade A has been given above, product grade B below the stepped line