

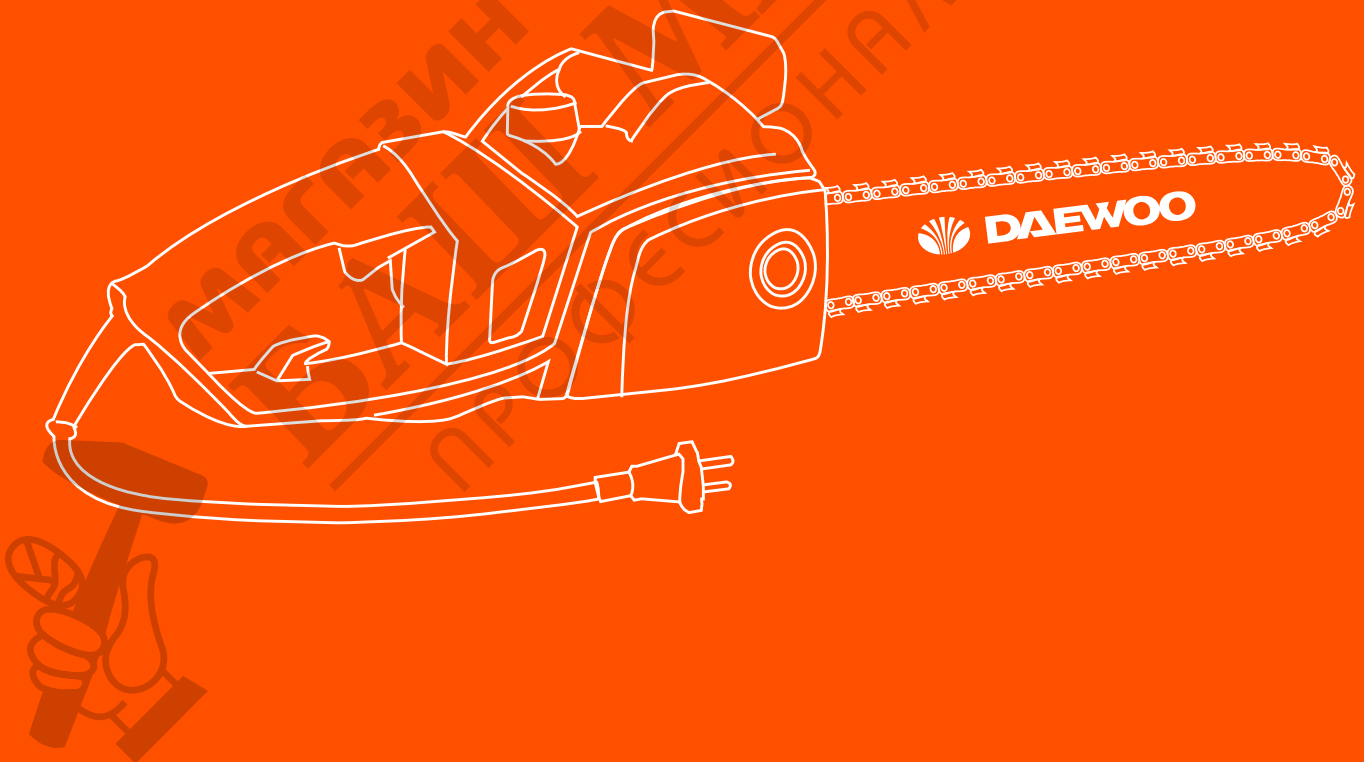

DAEWOO
POWER PRODUCTS

DCS2216E / 2416E
Electric Chainsaw



USER'S MANUAL

www.daewoopowerproducts.com

Manufactured under license of Daewoo International Corporation, Korea

INDEX

1. GENERAL SAFETY INSTRUCTIONS	6
2. ELECTRICAL SAFETY	7
3. MAINTENANCE	7
4. ASSEMBLY	9
5. OPERATION	11
6. USE	12
7. CLEANING AND MAINTENANCE	17
8. STORAGE AND TRANSPORT	19
9. DISPOSAL	19
10. TECHNICAL DATA	20
WARRANTY	21

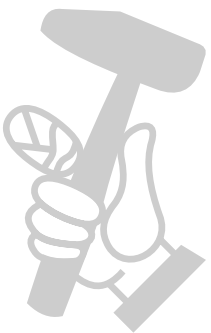

МАГАЗИН МАЙСТОРА®
БАШІ МАЙСТОРА®
ПРОФЕСІОНАЛНИ РЕШЕННЯ

1

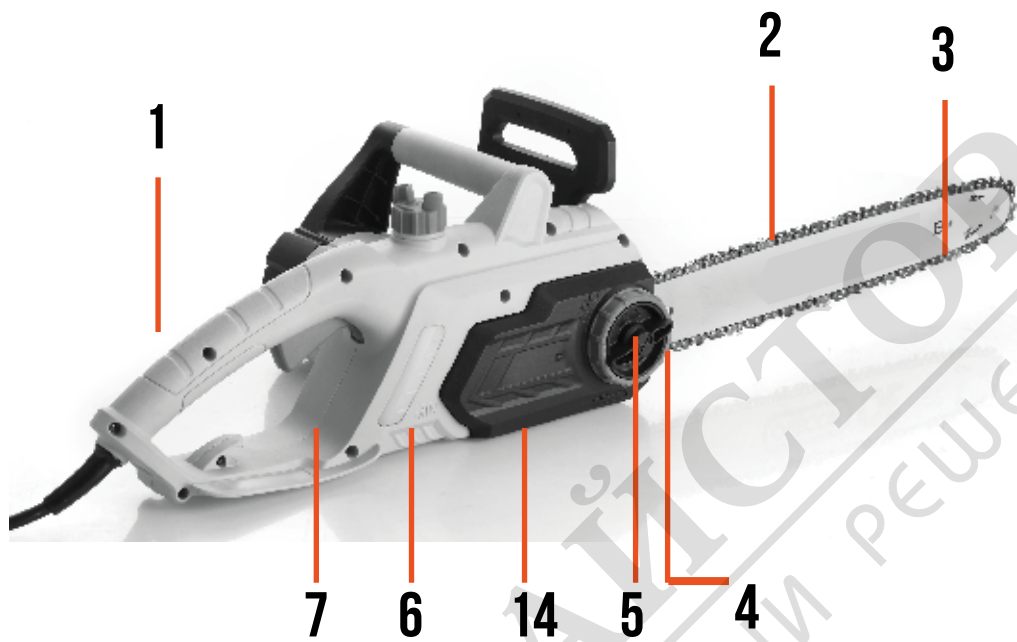

2

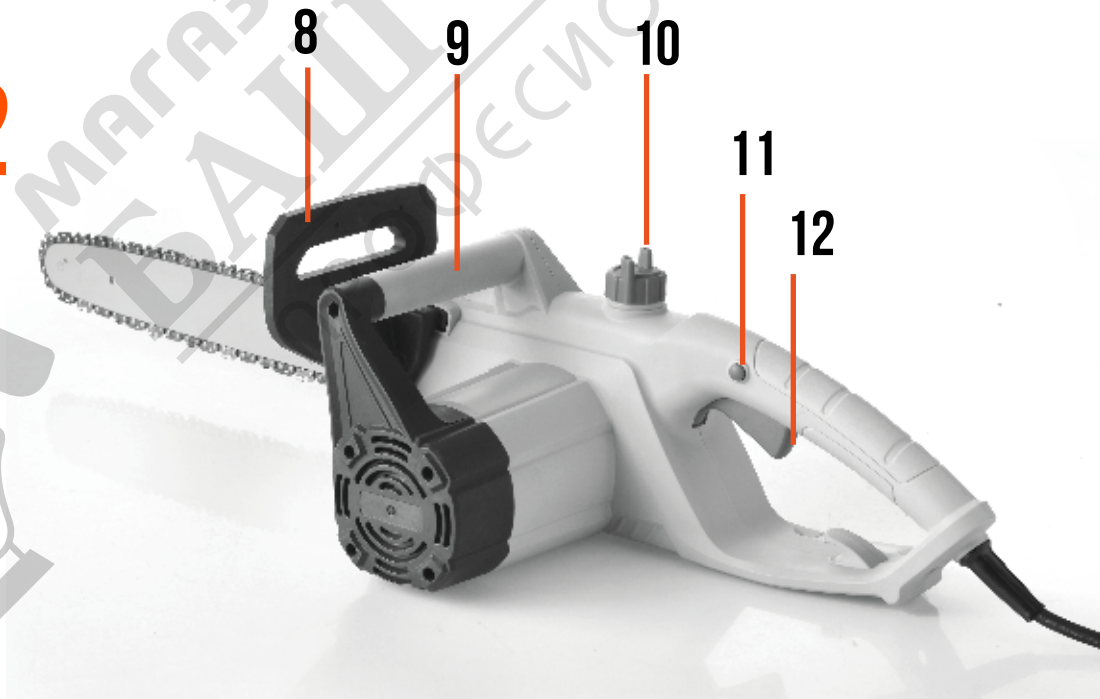

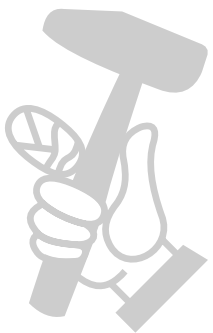
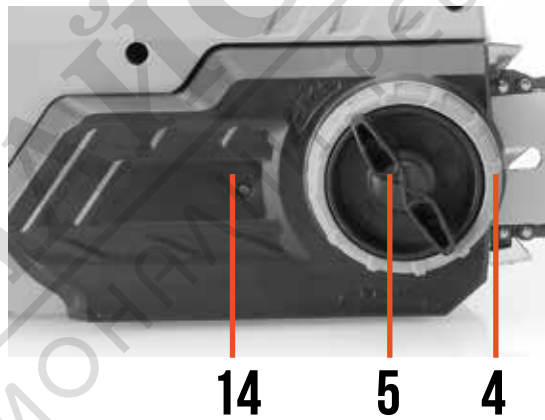
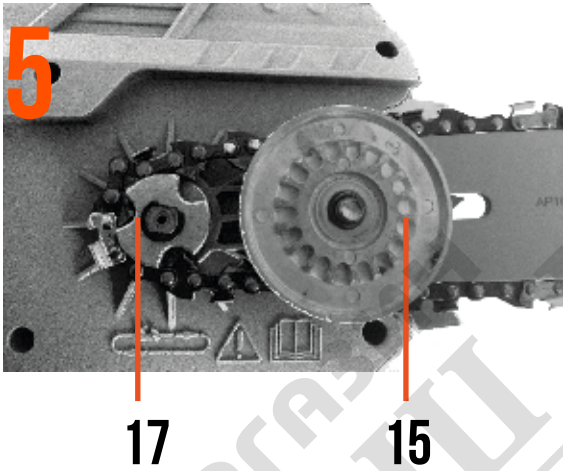
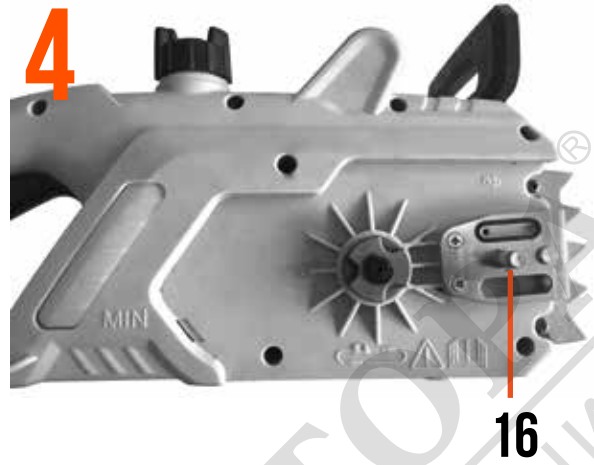
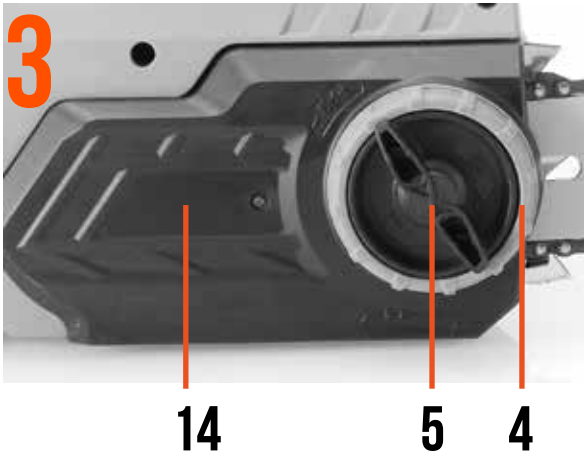

7

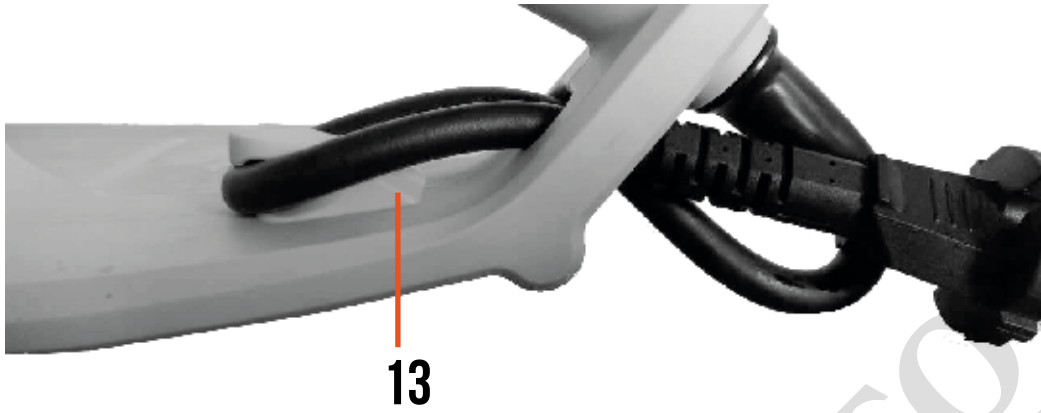

8

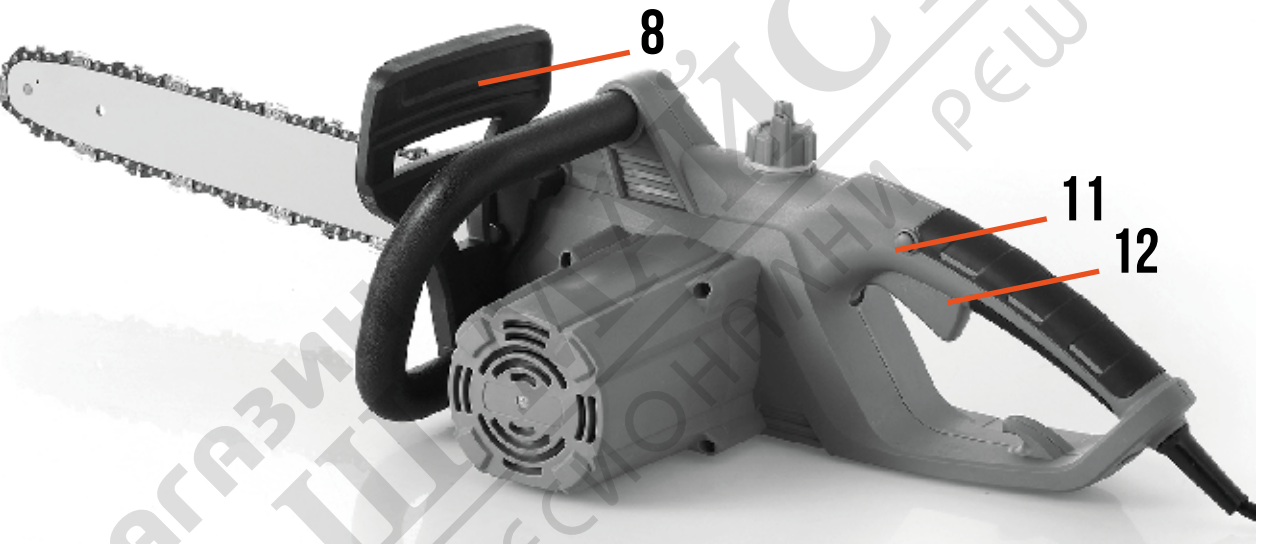

9

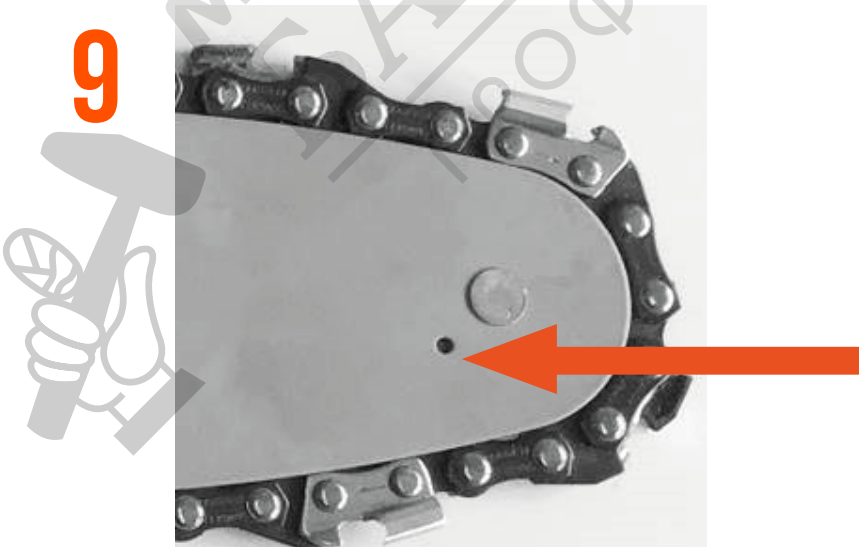

Dear customer,
Thank you for placing your trust in our product!
Before using the product for the first time, please make sure you read these operating instructions!
Here you will find information about how to use the product safely and ensure its long service life.
You should pay attention to all of the safety instructions in this document!

HOW TO USE THESE INSTRUCTIONS

All of the necessary diagrams can be found on the first pages of this set of instructions. Within the descriptions, you will be directed by cross-references to the appropriate diagrams.

Before you begin...

Intended use

When used for its intended purpose, this device corresponds to the state of the art, as well as to the current safety requirements at the time of its introduction.

This device may only be used with the approved original cutting chain for sawing wood.

The device is not suitable for commercial or industrial use.

Any other type of use is inappropriate. Improper use or modifications to the device or the use of components that are not tested and approved by the manufacturer may result in unforeseen damage! Any use that deviates from its intended use and is not included in these instructions is considered unauthorised use and relieves the manufacturer from his or her legal liability.

What are the meanings of the symbols used?

Danger notices and information are clearly marked throughout these instructions for use. The following symbols are used:



DANGER!

Direct danger to life and risk of injury!

Directly dangerous situation that may lead to death or severe injuries.



Note:

Information to help you reach a better understanding of the processes involved.



WARNING!

Probable danger to life and risk of injury!

Generally dangerous situation that may lead to death or severe injuries.



CAUTION!

Possible risk of injury!

Dangerous situation that may lead to injuries.



NOTICE!

Risk of damage to the device!

Situation that may lead to property damage.

These symbols identify the required personal protection equipment:



For your safety

1. GENERAL SAFETY INSTRUCTIONS

- To operate this device safely, the user must have read and understood these instructions for use before using the device for the first time.
- Observe all safety instructions! Failure to do so may cause harm to you and others.
- Retain all instructions for use, and safety instructions for future reference.
- If you sell or pass the device on, you must also hand over these operating instructions.
- The device must only be used when it functions properly. If the device or part of the device is defective, have it repaired by a specialist.
- Never use the device in a room where there is a danger of explosion or in the vicinity of flammable liquids or gases.
 - Always ensure that a device which has been switched off cannot be restarted unintentionally.
 - Do not use devices with an on/off switch that does not function correctly.
 - Keep children away from the device! Keep the device out of the way of children and other unauthorised persons.
 - Do not overload the device. Do not use the device for purposes for which it is not intended.
 - Make sure to always wear the required personal protective equipment.
 - Exercise caution and only work when in good condition: If you are tired, ill, if you have ingested alcohol, medication or illegal drugs, do not use the device, as you are not in a condition to use it safely.
 - This product is not intended to be used by persons (including children) or who are limited in their physical, sensory or mental capacities or who lack experience and/or knowledge of the product unless they are supervised, or have been instructed on how to use the product, by a person responsible for their safety.
 - Ensure that children are not able to play with the device.
 - Always comply with all applicable domestic and international safety, health, and working regulations.

Risks caused by vibrations

CAUTION!

Risk of injury due to vibrations!

Vibrations may, in particular for persons with circulation problems, cause damage to blood vessels and/ or nerves.

If you notice any of the following symptoms, stop working immediately and consult a doctor.

Numbness of body parts, loss of sense of feeling, itching, pins and needles, pain, changes in skin colour.

The vibration values specified in the technical data represent the main uses of the device. The actual existing vibrations during use may deviate from these as a result of the following factors:

- Incorrect use of the product;
- Unsuitable tools inserted;
- Unsuitable material;
- Insufficient maintenance.

You can reduce the risks considerably by following the tips below:

The rear hand guard– Avoid working at low temperatures.

- When it is cold, make sure your body and your hands, in particular, are kept warm.
- Take regular breaks and move your hands at the same time to promote circulation.

2. ELECTRICAL SAFETY

- The device may only be connected to a socket that is correctly installed and grounded. 
- The fuse must be a residual current circuit-breaker with a measured residual current of no more than 30 mA.
- Make sure that the power supply corresponds with the connection specifications of the device before it is connected.
- The tool may only be used within the specified limitations for voltage and power (see type plate).
- Do not touch the mains plug with wet hands! Always pull out the mains plug at the plug and not by the cable.
- Do not bend, crush, pull or drive over the power cable, protect from sharp edges, oil and heat.
- Do not lift the device using the cable or use the cable for purposes other than intended.
- Check the plug and cable before each use.
- If the power cable is damaged immediately disconnect the plug. Never use the device if the power cable is damaged.
- If the device is not in use make sure the plug is pulled out.
- Make sure that the device is switched off before plugging in the mains cable.
- Make sure that the device is switched off before unplugging it.
- Disconnect the power supply before transporting the device.

3. MAINTENANCE

- Before conducting any maintenance on the device, disconnect the mains plug.
- Only those maintenance and fault elimination tasks described here may be carried out. Any other tasks must be completed by a specialist.
- Only use original replacement parts. Only these replacement parts are designed and suitable for the device. Other replacement parts will not only lead to an invalidation of the warranty, they may also endanger you and your environment.

Device-specific safety instructions

- Young people under 18 years of age and users who are not sufficiently acquainted with its operation must not use the device
- Make sure that the device is assembled completely and according to regulations.
- Check the device to ensure that it works correctly, especially check the correct and secure fit of the chain rail, saw chain tensioned according to regulations and correct function of the chain brake.
- Check all screw connections regularly to ensure tight fit.
- Before use, ensure that there are no people or animals in the work area.
- Make certain that the work area is free of obstacles.
- Always keep an eye on your surroundings in order to ensure that you are not endangering any people or animals with your work.
- No other persons or animals may be present within an area of 15 m around the cutting area, as they may otherwise be hit by objects being slung away.
- Never work in poor light or weather conditions.
- Only saw wood. Do not use the chain saw for work for which it is not intended.
- Keep the handles dry, clean and free of oil and grease. Greasy, oily handles are slippery and cause loss of control.
- Avoid sawing in bushes, since here small branches may get caught in the saw chain and they can fly out uncontrolled.

- Make sure that you can stand firmly and safely in each work position. When working on a sloping subsurface, be especially careful!
- Always hold the device firmly in both hands. Use your right hand to grip the rear handle, your left hand to grip the other handle, even if you are left-handed. Do not let go of the handles!
- When the saw is running, keep all body parts away from the saw chain. Make sure before starting the saw that the saw chain does not touch anything.
- Never saw above shoulder height! Do not lean forward or back!
- Always ensure that you are standing firmly and only use the chain saw when you are standing on stable, firm and level ground. A slippery subsurface or instable standing area such as on a ladder can cause you to lose your balance or lose control over the chain saw.
- Do not stretch your arms too far forwards.
- Never work on ladders, on trees or in other positions in which you cannot stand safely.
- Take care when walking backwards. Danger of stumbling!
- Always saw at a high chain speed.
- Do not saw any wood which is under tension.
- Do not work alone! Ensure that you have an aural, visual or other connection with another person who is in a position to administer first aid in emergency situations.
- With each change of location, switch the motor off and activate the chain brake. The device may only be carried with the saw rail facing towards the back and a protective cover on.
- Never operate the device in moist or wet environments.
- Always keep the cable out of the working area of the device. Always guide the cable behind the device.
- If necessary, only use extension cables suitable for the device and its environment.
- Symbols appearing on your product may not be removed or covered. Information on the product that are no longer legible must be replaced immediately.



Observe the safety instructions before using the product for the first time.



Read and observe the operating instructions before commissioning.



Protect the device from wet conditions. Store in a dry location.



Remove the plug from the mains immediately if the cable is damaged or cut.

Personal protective equipment/sensible clothing

When cutting, wear the following protective equipment:



Head protection: safety helmet with visor / Ear protection: earplugs/ear muffs according to DIN EN 352-1 / Eye protection: wrap-around goggles/protective visor on the helmet



Foot protection: safety shoes with gripping soles, steel caps and leg protection



Hand protection: work gloves of leather



Clothing: safety overalls (cut-proof) Safety jacket (cut-proof)

Avoid with your clothing that you get caught on something:

- Wear only close-fitting clothing!
- Do not wear any jewellery!
- If you have long hair, wear a hair net!

Residual risks

Even when using correctly, there is still a element of residual risk that cannot be excluded.

- Contact with the unprotected saw chain (injury by cutting)
- Expulsion of parts of the saw chain

- Expulsion of parts of the cut items
- Damage to hearing
- Breathing in of particles from cut items
- Contact with petrol/oil

For this reason, it is essential that this chain saw is always used with the additional personal protective equipment as shown on the machine and described in these operating instructions. It is also necessary to observe the safety notes.

Your device at a glance

- P. 3, item 1

1. Handle
2. Saw chain
3. Chain bar
4. Chain Adjustment Ring
5. Fastening Bolt for Chain Sprocket Chain Wheel Cover
6. Sight glass for oil level
7. Rear hand guard
8. Hand guard
9. Handle
10. Fill opening for chain oil (tank cover)
11. Switch-on safety lock
12. Start button
13. Strain relief mechanism for extension cable
14. Chain Wheel Cover
15. Tension Plate
16. Bar bolt
17. Sprocket

Scope of delivery

- Drive unit
- Saw bar
- Saw chain
- Protective cover
- Instructions for use

 **Note:**
If one of the parts should be missing or damaged, please contact the vender.

4. ASSEMBLY



DANGER!

Risk of injury during operation!

Improperly mounted parts can cause severe and even fatal injuries when using the device! This device may only be commissioned if all parts are mounted completely and tightly and no part is damaged!

- Therefore, read the whole chapter before you assemble the parts!
- Assemble the parts carefully and completely.

- Use tools when their use is suggested.

**WARNING!****Risk of injury during assembly!**

Parts may only be assembled and disassembled when the motor is switched off (de-energise device).

CAUTION!

Risk of injuries due to cuts!

The teeth of the saw chain are very sharp! Protective gloves must be worn for all work on the chain.

DANGER!

Risk of injury!

An improperly mounted saw chain causes uncontrolled cutting behaviour of the device! When assembling the chain, heed the prescribed running direction.

Assembling the saw bar and saw chain

- Lay the saw on flat surface.
- Turn the fastening bolt (5) anti-clockwise and loose the chain adjustment ring (4) to remove the sprocket chain wheel cover (14) .
- To fit the new bar, place the bar (3) onto the bar bolt (16) with the tensioning plate (15) pointing outwards.

Note:

When attaching the chain, heed the correct position of the guide groove (saw rail).

- Spread the chain (2) out into a loop with cutting edges running clockwise. Relax the tensioning plate (15) against the clockwise direction.
- Slide the saw chain (2) into the bar guide groove. To mount the Chain bar (3), raise it to an angle of approx..45 degrees. This will make it easier to replace the saw chain (2) onto the sprocket (17). It is normal that the saw chain (2) is slack. Sagging in the chain is normal. .
- Pre-tighten the chain (2) by turning the tensioning plate (15) clockwise.
- Position the sprocket chain wheel cover (14). Only lightly tighten the fastening bolt (5) , as you will still have to tension the saw.

Tensioning the saw chain

- P. 5, item 6
- To tighten the chain, turn the chain adjustment ring (4) clockwise. To loosen the tension, the chain adjustment ring (4) anti-clockwise.
- Tighten the fastening bolt (5) again.

Letting the saw chain run in

During the run-in time, re-tension the saw chain and rail after a maximum of 5 cuts.

Checking the tensioning of the saw chain WARNING!

Risk of injury!

A new saw chain must be re-tensioned after a maximum of five cuts. This is normal during the run-in time; the intervals between subsequent re-tensionings will get larger.

The saw chain is tensioned correctly if it lies close against the underside of the saw rail and can be moved easily by hand.

Readjust tension of the saw chain when necessary (Re-tensioning the saw chain –p. 16).

If there is sufficient chain greasing, the oil spraying off of the saw chain will form a slight trail.[®]

Checking the chain greasing



NOTICE!

Device damage!

The device may not be used without sufficient chain greasing. Insufficient greasing reduces the service life of the device.

- Check the oil quantity in the tank.
- Start the device.
- Hold the running saw chain approx. 15 cm over a suitable surface for a time (15 s).

Filling up saw chain oil

- P. 5, item 6

NOTICE!

Environmental damage!

Since the saw chain oil can penetrate the environment during operation, biologically-degradable special vegetable-based saw chain oils should be used.

- Lay device securely with the tank cover (10) upwards.
- Before opening, clean the tank cover and the filler neck if necessary.
- Slowly open and remove the tank cover.
- Carefully fill up the saw chain oil. Do not spill!
- Read the oil level at the inspection glass (6).
- Tighten the tank cover by hand.
- If you have spilled any saw chain oil, be sure to wipe it up.

5. OPERATION

Safety equipment

The device has several pieces of safety equipment which reduce the risk of injury when working:

Chain catcher

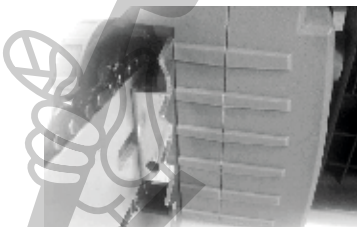

The chain catcher serves to catch a torn saw chain or one which has jumped out of the guide. Through regular maintenance of the saw rail and correct and regular tensioning of the saw chain, accidents of this type can be prevented.

The rear hand guard



The rear hand guard serves to protect the hand against a jumped chain and disturbing branches and twigs.

Check before starting!

DANGER!

Risk of injury!

The device must only be put into operation if no faults are found. If any part of the device is defective, it must be replaced before the next use.

Check the safety equipment and the safe condition of the device.

- Check all parts for their firm fit.
- Check whether there is any leakage.
- Check whether there are visible defects: broken parts, cracks, etc.
- Check the device for correct chain tensioning.
- Check the function of the chain brake.

Attaching the extension cable

- item 7
- Plug the unit plug into the connector of the extension cable.
- Feed the extension cable through the strain relief mechanism (13) as shown.

Starting the device

item 8

- Hold the device fast with both hands.
- The hand guard (8) must be folded towards the back.
- Press the switch-on safety lock (11).
- Press the start button (12). The device starts up.

6. USE



Before use, familiarize yourself sufficiently with the sawing technique for chain saws. You will find information about this in the trade literature. We recommend that you attend suitable training sessions. The notes here serve only as a complement!

Correct posture



DANGER!

Risk of injury!

Never work on unstable subsurfaces!
Never work above shoulder height!
Never work while standing on a ladder!
Do not work bent too far forward!
Only use the device under favourable weather and site conditions!

- Stand with both legs securely on the ground.
- Heed obstacles in the work area.
- While you are working, always hold the device fast with both hands!

Hold the device:

- with the left hand on the handle.
- with the right hand on the handle.
- balanced in a secure position.

Here's how to saw correctly!

DANGER!

Risk of injury!

Always switch the motor off before you put the device down!

- Search the work area and remove objects which are in your way.
- When you begin work, check the safety of the device (Check before starting! – p. 13).
- Take the device in both hands as instructed.

Risk of rebound!

Rebounds occur if the upper edge or tip of the saw rail touch wood or other hard objects. The device is thrown with high energy back and forth, which can cause extremely severe injuries.

DANGER!

Risk of injury!

When working with the device, dangerous rebounds may occur! Severe or even fatal injuries can be the result! Before beginning work with the device, the chain brake must be checked to ensure that it is functioning correctly.

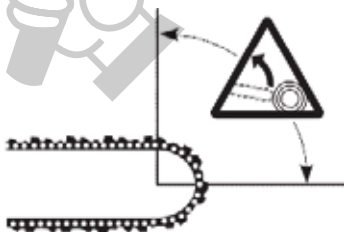

Avoid letting the area of the saw rail depicted on the right touch wood or other hard objects. In order to reduce the risk of injury in case of a rebound, the device is equipped with a chain brake which is triggered automatically on impact and which stops the saw chain immediately. For safety reasons, the functionality of the chain brake must be checked each time the device is used (Checking the chain brake – p. 12). With less strong rebounds, it can happen that the chain brake is not triggered automatically. For this reason it is important that the device be held fast with both hands.

Only a careful and correct working method can reduce the risk of a rebound reliably!

Basic work technique

DANGER!

Risk of injury!

This section treats the basic work technique when handling the device. The information provided here does not replace the many years of training and experience of a professional. Do not perform any work for which you are not sufficiently qualified! Thoughtless handling of the device can cause severe or even fatal injuries!

Before each use

1. Check the chain brake to ensure it is functioning correctly.
2. Check the rear hand guard for damage.
3. Check the switch-on safety lock and start button to ensure they are functioning correctly.
4. Check whether all handles are free of oil.
5. Check whether all parts of the device are present, firmly attached and undamaged.
6. Check the chain catcher for damage.
7. Check the chain tensioning.

Sawing technique Pulling sawing

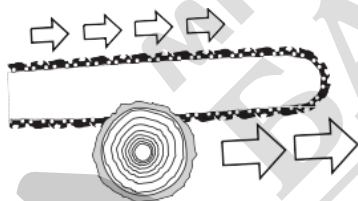

With this technique, sawing occurs with the underside of the saw rail from above downwards. The saw chain thus pushes the device forwards away from the user. This way, the front edge of the device forms a support, which catches the forces which arise on the tree trunk when sawing. With pulling sawing, the user has much more control over the device and can avoid rebounds better. Therefore, this is the preferred sawing technique.

Pushing sawing

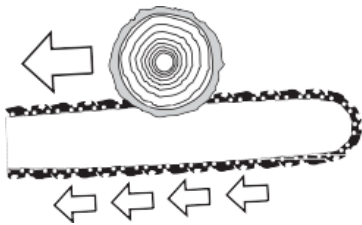

With this technique, sawing occurs with the upper edge of the saw rail from below upwards. The saw chain thus pushes the device backwards towards the user. If the saw rail twists, the device can fly towards the user with great force.

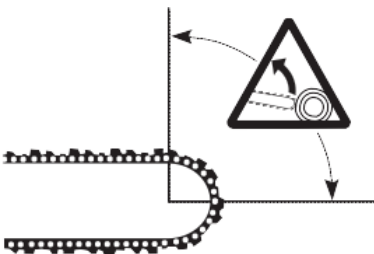

If the user does not balance out the force of the saw chain pushing backwards with his or her bodily force, there is a danger that only the tip of the saw rail will make contact with the wood and there will thus be a rebound (Risk of rebound!).

Felling a tree



DANGER!

Risk of injury!

Felling and delimiting work may only be performed by trained people!
There is a risk of fatal injuries!

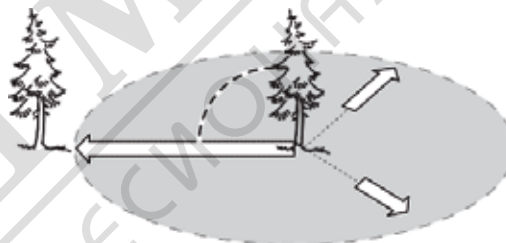

Before beginning the felling work, make sure that:

- there are no people or animals in the felling area of the tree.
- there is an obstacle-free escape route for each participant. A retreat occurs diagonally counter to the felling direction.
- the area around the trunk is free of obstacles (risk of stumbling!).
- the next workplace is at least two and a half tree lengths away. Before felling, the felling direction of the tree must be checked and it must be ensured that there are no objects, people or animals in a distance of 2 1/2 tree lengths.

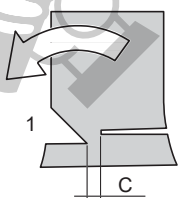

The felling of a tree occurs in two steps:

1. Notch the trunk by approximately one-third of its diameter on the felling direction side.
2. On the other side, make the felling cut, which must be somewhat higher than the felling notch (approx. 3-5 cm).

DANGER!

Risk of injury!

Never saw the tree trunk completely through. The area serves as a "hinge" and ensures a defined felling direction.

DANGER!

Risk of injury!

When felling, stand only to the side of the tree to be felled! There is a risk of fatal injuries!

Trunks lying flat on the ground

– Cut into the trunk halfway, then turn over and saw through from the opposite side.

NOTICE!

Device damage!

Make sure that the saw rail does not touch the ground while you are sawing through the trunk!

Propped-up trunks

We recommend that you place trunks to be sawed through on sawhorses. If this is not possible, the trunk should be lifted with the help of supporting branches and placed over trestles.

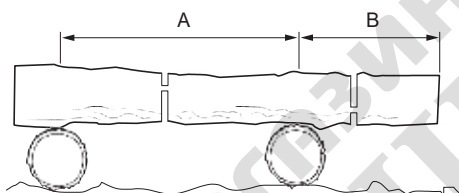

In area A, first cut through approximately one third of the trunk diameter from above downwards, then make the final cut from below upwards. In area B, first cut through approximately one third of the trunk diameter from below upwards, then saw through from above.



DANGER!

Risk of injury!

Do not saw any trunks under tension!
Splintering wood or a twisted saw rail
can cause extremely severe injuries!

Removing branches

- Always work on the side opposite the branch in question.
- Begin at the bottom of the trunk and work upwards.
- Always guide the saw from above downwards through the wood.

When removing the branches from trunks which are lying down, first saw off the free branches sticking up in the air. Only saw off supporting branches when the trunk is sawed in lengths.

DANGER!

Risk of injury!

Branches that are high up or under tension can wedge the saw chain in the wood!

7. CLEANING AND MAINTENANCE

DANGER!

Risk of injury!

Before any maintenance or cleaning work:

- Pull out the plug.
- Let the device cool down.

DANGER!

In the interest of your own safety!

Only perform the maintenance work described here yourself.

Any other work, especially motor maintenance and repairs must be performed by a trained professional. Improper work can cause damage to the device and thus also injuries.

Cleaning and maintenance overview

After each use

What?	How?
Clean the device	▶ Cleaning the device -

Regularly, depending on the conditions of use

What?	How?
Re-tension saw chain	▶ Re-tensioning the saw chain
Clean oil guide groove of the saw rail.	▶ cleaning the oil guide groove of the saw rail -
Sharpen the saw chain.	▶ sharpening the saw chain

Cleaning

Cleaning the device

- Re-tensioning the saw chain – p. 16
- cleaning the oil guide groove of the saw rail – p. 16
- sharpening the saw chain – p. 17

DANGER!

Risk of injury!

Branches that are high up or under tension can wedge the saw chain in the wood!

- Remove coarse dirt.
- Wipe down the device with a slightly damp cloth.

Cleaning the oil guide groove of the saw rail

NOTICE!

Device damage!

To clean the saw rail, use only a plastic spatula, never a steel tool.

- Remove the saw rail.
- Clean dirt from the oil guide groove of the saw rail with a suitable tool.
- Replace saw bar (Assembling the saw bar and saw chain).

Re-tensioning the saw chain
item 6

- Loosen the fastening bolt (5) by approximately one turn.
- Lift the tip of the saw bar slightly.
- Tighten the Chain Adjustment Ring for chain tension (4) until the chain lies on the underside of the saw rail.

Lubricating chain wheel
item 9

The bearing of the chain wheel should be regularly lubricated at the front-end of the rail. About 1x in a week in case of intensive use.

- Clean the lubrication hole.
- Apply little multi-purpose grease in the lubrication hole, while moving the chain with hand.

Sharpening the saw chain

DANGER!

Danger of death!

A worn or improperly sharpened chain can cause rebounds. Severe or even fatal injuries can be the result!

Note:

Special tools are required to sharpen the saw chain; these guarantee that the cutting of the chain occurs at the correct angle and the correct depth. We recommend that you have the saw chain sharpened by a professional.

8. STORAGE AND TRANSPORT

Storage

DANGER!

Risk of injury!

Make sure that unauthorized persons do not have access to the device!

Fault/malfunction	Cause	Remedial measure
Motor not running.	No mains voltage?	Check cable, plug, socket and fuse.
	Cable faulty?	Have replaced by an electrician.

- Let the device cool down before you store it.
- Store the device as horizontally as possible.

Longer downtimes

If you are not going to be using the device for a while, remove the chain oil from the device. Store the device in a dry place.

Transport

If you are transporting the device in a vehicle:

- Slip the protective cover onto the cutting tool.
- Secure the device against slipping.
- If possible, use the original packaging for dispatching.

Faults and remedial measures

When something isn't working...

DANGER!

Risk of injury!

Improperly performed repairs can lead to the device not functioning safely. This endangers yourself and your environment.

Often only small faults cause a malfunction. You can usually easily remedy such faults yourself.

Please consult the following table before contacting your local store. This saves effort and possibly also costs.

If you are unable to remedy the fault yourself, please contact your local store. Please note that improper performance of repair work will lead to the loss of any warranty claims and that additional costs may be incurred.

9. DISPOSAL

Disposal of the appliance Appliances which are labelled with the adjacent symbol must not be dis-

posed of in household waste. You must dispose of such old electrical and electronic equipment separately.

– Please check with your local authority about the possibilities for correct disposal. Through separate disposal you send old equipment for recycling or for other forms of re-use. You will thus help to avoid in some cases that damaging material gets into the environment.

Disposal of the packaging The packaging consists of cardboard and correspondingly marked plastics that can be recycled.

– Make these materials available for recycling.

10. TECHNICAL DATA

DCS2216E

Voltage/frequency: 220-240V~50 Hz

Power: 2200 W

Bar length: 405 mm (16")

Cutting speed: 13 m/s

No load speed: 7000 rpm

Oil tank capacity: 340 ml

DCS2416E

Voltage/frequency: 220-240V~50 Hz

Power: 2400 W

Bar length: 405 mm (16")

Cutting speed: 13 m/s

No load speed: 7000 rpm

Oil tank capacity: 340 ml

The specified values are emission values and do not necessarily represent safe workplace values. Although there is a correlation between emission and immission levels, this cannot be used to infer whether additional safety measures are necessary or not. Factors which affect the current immission levels at the workplace, include the type of room, other sources of noise, e. g. the number of machines operating and other processes taking place in the vicinity. Permitted workplace values can differ from country to country. This information is designed to help the user to better assess the dangers and risks.

***) The specified vibration emission value was measured in accordance with a normed test procedure and can be used in order to compare one tool with another. The specified vibration emission value can also be used for an introductory evaluation of the exposure. The vibration emission value may fluctuate from the specified value during actual use of the power tool. These fluctuations will depend on the way in which the power tool is used. Try to keep vibrations to a minimum. One method of reducing the vibration load is, for example, limiting the length of time you work with the tool. All parts of the operating cycle must be taken into account for this purpose (for example, also including times in which the power tool is switched off and times in which it is switched on, but is running without load).

Appropriate chain oil

NOTICE!

Risk of damage to the device!

Under no circumstances should you use old oil to grease the saw chain! This can cause damage to the oil pump, saw rail and chain!

Use only special saw chain oils with good adhesion properties. Since the saw chain oil can penetrate the environment during operation, biologically-degradable special vegetable-based saw chain oils should be used.



DAEWOO
POWER PRODUCTS



МАГАЗИН МАЙСТОРА®
БАШ ПРОФЕСИОНАЛЬНИ РЕШЕНИЯ

www.daewoopowerproducts.com

Manufactured under license of Daewoo International Corporation, Korea