



# DAEWOO

POWER PRODUCTS

## DASP 400

Paint gun



### USER'S MANUAL

[www.daewoopowerproducts.com](http://www.daewoopowerproducts.com)

Manufactured under license of Daewoo International Corporation, Korea

# INDEX

<b>1. SAFETY INFORMATION</b> .....	2
<b>2. COMPONENTS</b> .....	3
<b>3. SETUP</b> .....	4
<b>4. THINNING CHART</b> .....	5
<b>5. CLEANUP</b> .....	8
<b>6. MAINTENANCE</b> .....	10
<b>7. TROUBLESHOOTING</b> .....	11
<b>WARRANTY</b> .....	13

МАГАЗИН  
**БАШ МАЙСТОРА**<sup>®</sup>  
ПРОФЕСІОНАЛНИ РЕШЕННЯ

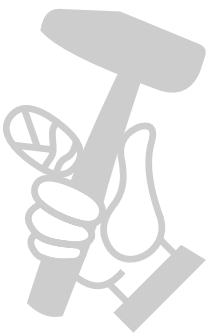

## 1. SAFETY INFORMATION

• *Read all safety information before operating the equipment. Save these instructions To reduce the risks of fire or explosion, electrical shock and the injury to persons, read and understand all instructions included in this manual. Be familiar with the controls and proper usage of the equipment. Indicates a hazardous situation which, if not avoided, could result in death or serious injury.*

### HAZARD: EXPLOSION OR FIRE

Solvent and paint fumes can explode or ignite.

Severe injury or property damage can occur.

#### PREVENTION:

- Provide extensive exhaust and fresh air introduction to keep the air within the spray area free from accumulation of flammable vapors.
- Avoid all ignition sources such as static electric sparks, open flames, pilot lights, electrical appliances, and hot objects. Connecting or disconnecting power cords or working light switches can make sparks.
- Do not smoke in spray area.
- Fire extinguisher must be present and in good working order.
- Use only outdoors in a well-ventilated area. Flammable vapors are often heavier than air. The turbine contains arcing parts that emit sparks and can ignite vapors.
- Follow the material and solvent manufacturer's warnings and instructions.
- Do not use materials with a flashpoint below 70°F (21°C). Flashpoint is the temperature that a fluid can produce enough vapors to ignite (see coating supplier).
- Plastic can cause static sparks. Never hang plastic to enclose the spray area. Do not use plastic drop cloths when spraying flammable materials.

### HAZARD: EXPLOSION HAZARD DUE TO INCOMPATIBLE MATERIALS.

Will cause property damage or severe injury.

#### PREVENTION:

- Do not use materials containing bleach or chlorine.
- Do not use halogenated hydrocarbon solvents such as bleach, mildewcide, methylene chloride and 1,1,1-trichloroethane. They are not compatible with aluminum.
- Contact your coating supplier about the compatibility of material with aluminum.

### HAZARD: HAZARDOUS VAPORS

Paints, solvents, insecticides, and other materials can be harmful if inhaled or come in contact with the body. Vapors can cause severe nausea, fainting, or poisoning.

#### PREVENTION:

- Use a respirator or mask if vapors can be inhaled. Read all instructions supplied with the mask to be sure it will provide the necessary protection.
- Wear protective eyewear.
- Wear protective clothing as required by coating manufacturer.

### HAZARD: GENERAL

Can cause severe injury or property damage.

#### PREVENTION:

- Read all instructions and safety precautions before operating equipment.
- Follow all appropriate local, state, and national codes governing ventilation, fire prevention, and operation.
- Use only manufacturer authorized parts. User assumes all risks and liabilities when using parts that do not meet the minimum specifications and safety devices of the turbine manufacturer.

- Do not spray outdoors on windy days.
- Wear protective clothing to keep paint off skin and hair.
- Never aim spray gun at any part of the body.

Household use only. Intended for outdoor use ONLY with materials having flashpoint above 70°F (21°C).

- Read all safety information before operating the equipment. Save these instructions

### Important Electrical Information

1. The tool plug must fit into the socket. The plug may not be modified in any form. Do not use adaptor plugs together with protective-earthed tools. Unmodified plugs and suitable sockets reduce the risk of an electric shock.
2. Avoid physical contact with earthed surfaces such as pipes, heating elements, stoves and refrigerators. The risk through electric shock increases if your body is earthed.
3. Keep the equipment away from rain and moisture. The risk of an electric shock increases if water penetrates electrical equipment.
4. Do not misuse the mains lead by carrying the tool by the lead, hanging it from the lead or by pulling on the lead to remove the plug. Keep the lead away from heat, oil, sharp edges or moving tool parts. Damaged or twisted leads increase the risk of an electric shock.
5. If you work outdoors, use only extension leads that are approved for outdoor use. The use of an extension lead that is suitable for outdoors reduces the risk of an electric shock.

## 2. COMPONENTS

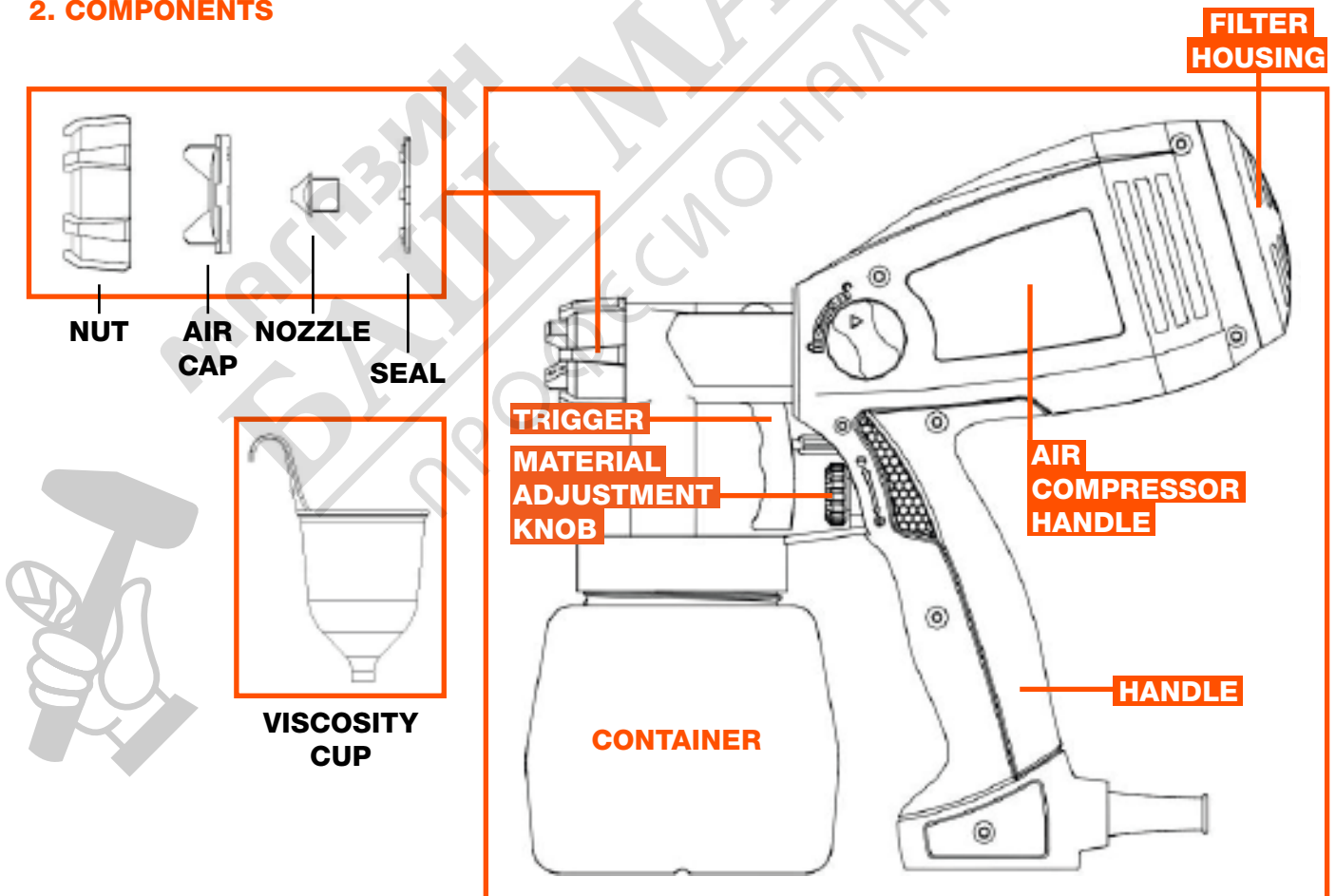

### 3. SETUP

1. Turn both knobs on both sides of the Air Compressor Assembly to the “Unlock” position, and Insert the spray gun into the Air Compressor Assembly into place,
2. Turn both knobs on both sides of the Air Compressor Assembly to the “Lock” position to lock the two pieces into place.

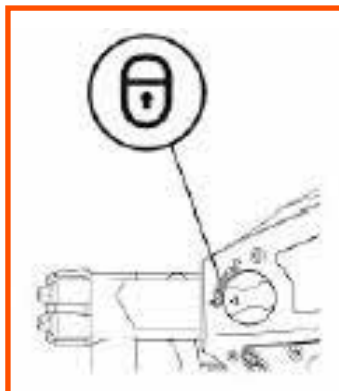
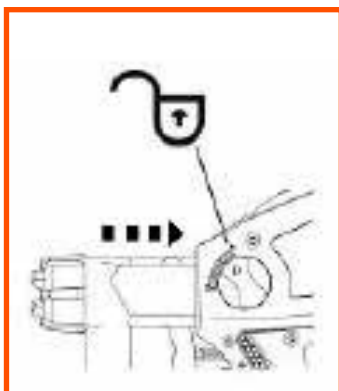

Aligning the Suction Tube If you are going to be spraying in a downward direction, the angled end of the suction tube should be pointing toward the front of the gun.

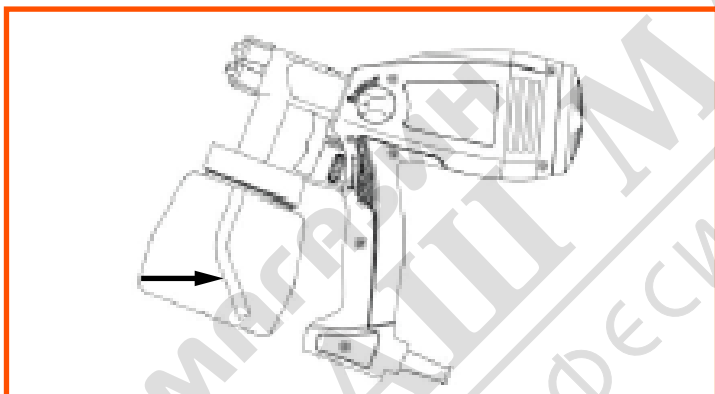

If you are going to be spraying in an upward direction, the angled end of the suction tube should be pointing toward the rear of the gun.

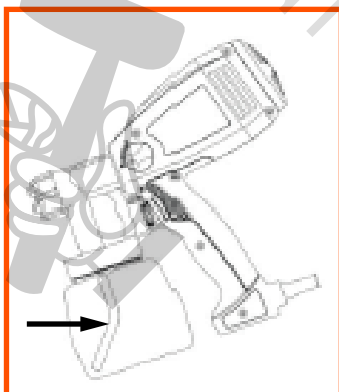

By pointing the suction tube in the proper direction, you will not have to refill the container as often..  
**Material Preparation** Before spraying, the material being used may need to be thinned with the proper solvent as specified by the material manufacturer. Never exceed the thinning advice given by the coating manufacturer. Do not use materials with a flashpoint below 70°F (21°C). Follow the instructions below.

1. Stir the spraying material thoroughly before measuring viscosity.
2. Dip the viscosity test cup completely into the spraying material.



3. Hold the test cup up and measure the time in seconds until the liquid empties out. This time is referred to below as Runout Time.

### 3. THINNING CHART

#### Material

- 1) Oil enamel
- 2) Oil based primer
- 3) Oil stain
- 4) Clear sealer
- 5) Polyurethane
- 6) Varnish

#### Runout Time

- 25-40
- 30-45
- No thinning required
- No thinning required
- No thinning required
- 20-50

*Material to be sprayed should always be strained to remove any impurities in the paint which may enter and clog the system. Impurities in the paint will give poor performance and a poor finish.*

**MATERIAL FLASH POINT MUST BE 70°F (21°C) OR HIGHER.**

#### Fill Container

1. Unscrew the cup from the spray gun.
2. After the material has been properly thinned and strained, fill the container to the top of the neck.

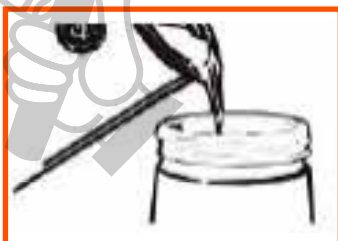

3. Carefully screw the cup back onto the spray gun.

**Spraying** The spray pattern shape is adjusted by turning the ears of the air cap to either the vertical, horizontal, or diagonal positions. The positions of the air cap and the corresponding spray pattern shapes are illustrated below. Test each pattern and use whichever pattern is suitable for your application.

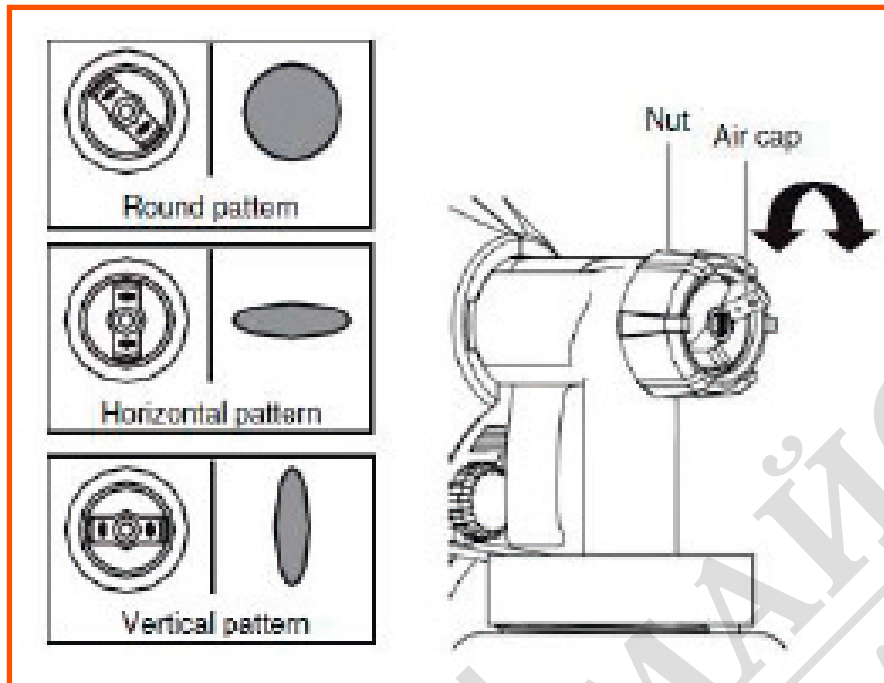

**NEVER** trigger the gun while adjusting the ears on the air cap. **NEVER** point the spray gun at any part of the body.

**Material Flow Adjustment** Set the material volume by turning the regulator behind the trigger of the spray gun.

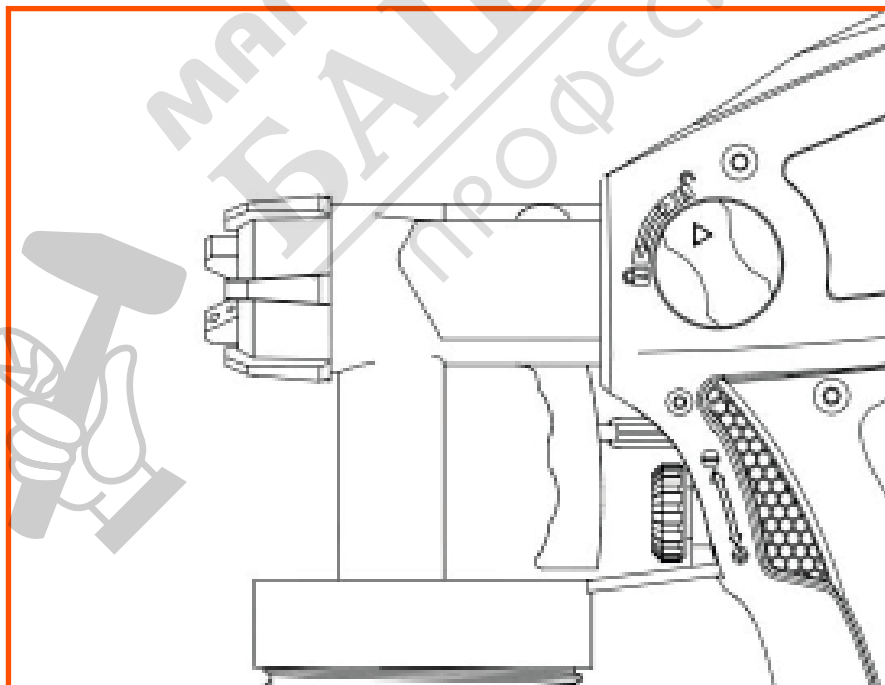

**Proper Spraying Technique** If spraying with an HVLP spray system is new or unfamiliar to you, it is advisable to practice on a piece of scrap wood or cardboard before beginning on your intended workpiece.

**Surface Preparation**

All objects to be sprayed should be thoroughly cleaned before spraying material on them. Areas not to be sprayed may, in certain cases, need to be masked or covered.

**Spray Area Preparation - outdoor use only**

The spray area must be clean and free of dust in order to avoid blowing dust onto your freshly sprayed surface.

**How to Spray Properly**

- Position the spray gun perpendicular to and one (1) or more inches from the spray surface, depending upon the spray pattern size desired.
- Spray parallel to the surface with smooth passes at a consistent speed as illustrated below. Doing this will help avoid irregularities in the finish (i. e. runs and sags).
- Always apply a thin coat of material on the first pass and allow to dry before applying a second, slightly heavier coat.
- The closer your sprayer is to the object being sprayed the lower the overspray.

**Even coat throughout**

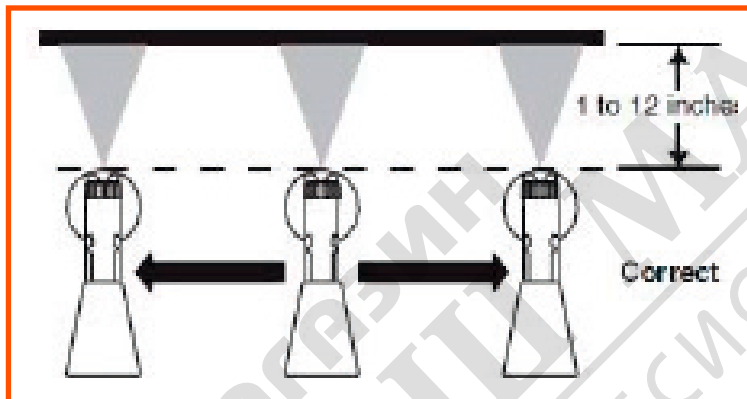

**Keep stroke smooth and at an even speed**

- When spraying, always trigger the spray gun after spray pass has begun and release trigger before stopping the pass. Always keep the gun pointed squarely at the spray surface and overlap passes slightly to obtain the most consistent and professional finish possible.

Light coat      Heavy coat      Light coat

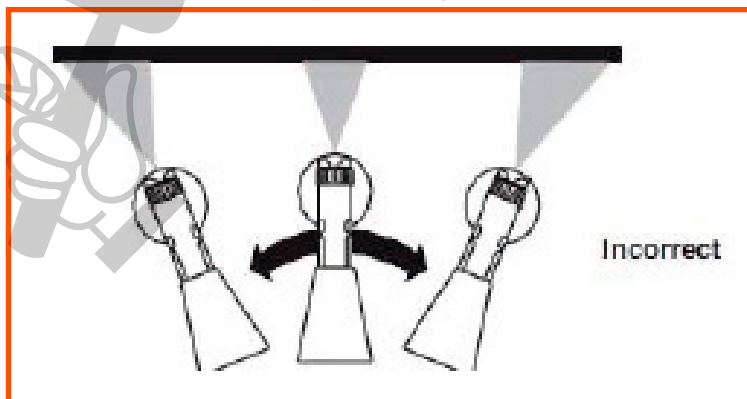

Do not flex wrist while spraying.

#### 4. CLEANUP

##### *Cleaning the Spray Gun*

*Special cleanup instructions for use with flammable solvents (must have a flashpoint above 70°F (21°C):*

- *Always flush spray gun outside.*
- *Area must be free of flammable vapors.*
- *Cleaning area must be well-ventilated.*
- *DO NOT SUBMERGE Air Compressor!*

1. Unplug the spray gun, and trigger the spray gun so that the material inside the spray gun flows back into the container.



2. Unscrew the container.

Empty any remaining material back into the material container.

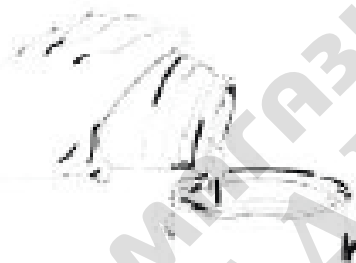

3. Pour a small amount of the appropriate cleaning solution into the cup (warm, soapy water for latex materials; mineral spirits for oil-based materials). Clean cup and properly dispose of cleaning solution.

4. Refill the cup with NEW cleaning solution.



5. Attach the cup to the gun and plug in the sprayer.



6. Spray the solution through the gun for two seconds in a safe area. Spray again for two seconds. Unplug the spray gun, and trigger the spray gun so that the material inside the spray gun flows back into the container.

7. Wipe the exterior of the cup and gun until clean.

8. Unscrew the nut and remove the air cap and nozzle.

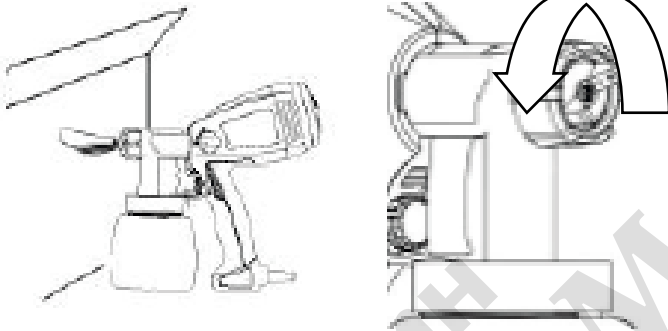

9. Clean the container, suction tube, air cap and nozzle with a cleaning brush and the appropriate cleaning solution.



*Never clean nozzle or air holes in the spray gun with sharp metal objects. Do not use solvents or lubricants containing silicone.*

10. Turn both knobs on both sides of the Air Compressor Assembly to the “Unlock” position, pull and separate the spray gun from the Air Compressor Assembly.

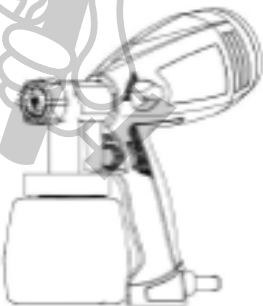

11. (a) Clean the rear of the spray gun with the appropriate cleaning solution.  
(b) Turn the suction tube anti-clockwise and pull the suction tube downward to disassemble it from the spray gun. Then clean the suction tube with the appropriate cleaning solution. Attention! The Seal Ring (4) between Suction Tube 1(3) and Suction Tube 2 (5) must be put back into place after cleaning. Otherwise, some paint in the container will be sucked into the air duct and interfere with the function of the unit.

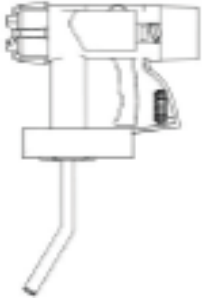

## 5. MAINTENANCE

You should inspect the air filter in the Air Compressor Assembly to see if it is excessively dirty. If it is dirty, follow the steps below to replace it.

1. Unplug the spray gun. Remove the filter cover with a tool (such as a flat screw driver)



2. Remove the dirty filters and replace with new ones.



3. Secure the cover back onto the turbine.  
Never operate your unit without the air filters. Dirt could be sucked in and interfere with the function of the unit.



## 6. TROUBLESHOOTING

Problem	Cause	Solution
A. Little or no material flow	<ol style="list-style-type: none"> <li>1. Nozzle clogged.</li> <li>2. Suction tube clogged.</li> <li>3. Material volume setting turned too low(-).</li> <li>4. Suction tube loose.</li> <li>5. No pressure build up in container.</li> <li>6. Air filter clogged.</li> </ol>	<ol style="list-style-type: none"> <li>1. Clean.</li> <li>2. Clean.</li> <li>3. Increase volume setting (+).</li> <li>4. Insert.</li> <li>5. Tighten container.</li> <li>6. Change.</li> </ol>
B. Material leaking	<ol style="list-style-type: none"> <li>1. Nozzle loose.</li> <li>2. Nozzle worn.</li> <li>3. Nozzle seal worn.</li> <li>4. Material build-up on air cap and nozzle</li> </ol>	<ol style="list-style-type: none"> <li>1. Tighten.</li> <li>2. Replace.</li> <li>3. Replace.</li> <li>4. Clean.</li> </ol>
C. Atomization is too coarse	<ol style="list-style-type: none"> <li>1. Viscosity of material too high.</li> <li>2. Material volume too large.</li> <li>3. Material volume setting too high (+).</li> <li>4. Nozzle clogged.</li> <li>5. Air filter clogged.</li> <li>6. Too little pressure build-up in container.</li> </ol>	<ol style="list-style-type: none"> <li>1. Thin.</li> <li>2. Decrease volume setting (-).</li> <li>3. Decrease volume setting (-).</li> <li>4. Clean.</li> <li>5. Change.</li> <li>6. Tighten container.</li> </ol>
D. Spray jet pulsates	<ol style="list-style-type: none"> <li>1. Material in container running out.</li> <li>2. Air filter clogged.</li> </ol>	<ol style="list-style-type: none"> <li>1. Refill.</li> <li>2. Change.</li> </ol>
E. Pattern runs or sags	<ol style="list-style-type: none"> <li>1. Applying too much material.</li> </ol>	<ol style="list-style-type: none"> <li>1. Adjust material flow or increase movement of spray gun.</li> </ol>
F. Too much overspray	<ol style="list-style-type: none"> <li>1. Gun too far from spray object.</li> <li>2. Too much material applied.</li> </ol>	<ol style="list-style-type: none"> <li>1. Reduce distance.</li> <li>2. Decrease volume setting (-).</li> </ol>
G. Pattern is very light and splotchy.	<ol style="list-style-type: none"> <li>1. Moving the spray gun too fast</li> </ol>	<ol style="list-style-type: none"> <li>1. Adjust material flow or decrease movement of spray gun.</li> </ol>

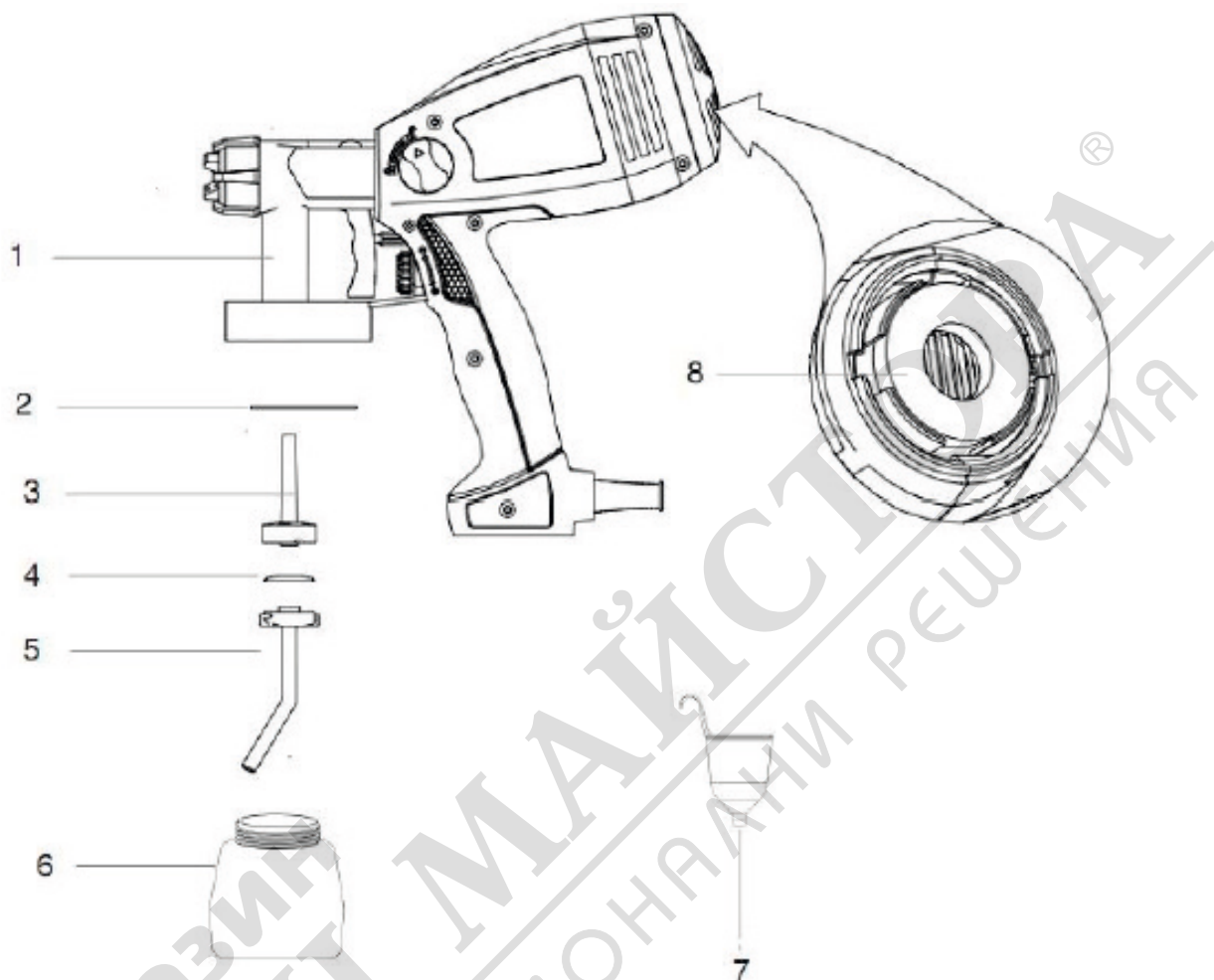

Number	Part Description	Quantity
1	Sprayer Assembly	1
2	Container Seal	1
3	Suction Tube	1
4	Seal Ring	1
5	Suction Tube 2	1
6	Container	1
7	Viscosity Cup	1
8	Air Filter	1
9	Air Compressor Assembly	1

## WARRANTY CARD

Product model	Date of sale
Serial number	Company
Username	Client's signature

The product is in good conditions and fully complete. Read and agree the terms of the warranty.

## GUARANTEE

The warranty period starts from the date of sale of the products and covers 1 year for all power products.

During the warranty period, free failures caused due to the use of poor-quality materials in the production and manufacturer workmanship admitted fault are removed. The guarantee comes into force only when warranty card and cutting coupons are properly filled. The product is accepted for repair in its pure form and full completeness.

## WARRANTY DOES NOT COVER

- Mechanical damage (cracks, chips, etc.) and damage caused by exposure to aggressive media, foreign objects inside the unit and air vents, as well as for damage occurred as a result of improper storage (corrosion of metal parts);
- Failures caused by overloading or product misuse, use of the product for other purposes. A sure sign of overload products is melting or discoloration of parts due to the high temperature, simultaneous failure of two or more nodes, teaser on the surfaces of the cylinder and the piston or destruction of piston rings. Also, the warranty does not cover failure of the automatic voltage regulator due to incorrect operation;
- Failure caused by clogging of the fuel and cooling systems;
- Wearing parts (carbon brushes, belts, rubber seals, oil seals, shock absorbers, springs, clutches, spark plugs, mufflers, nozzles, pulleys, guide rollers, cables, recoil starter, chucks, collets, removable batteries, filters and safety elements, grease, removable devices, equipment, knives, drills, etc.);
- Electrical cables with mechanical and thermal damage;
- Product opened or repaired by a non-authorized service center.
- Prevention, care products (cleaning, washing, lubrication, etc.), installation and configuration of the product;
- Natural wear products (production share);
- Failures caused by using the product for the needs related to business activities;
- If the warranty card is empty or missing seal (stamp) of the Seller;
- The absence of the holder's signature on the warranty card.

DAEWOO
DAEWOO
DAEWOO

Product _____ Model _____ Company _____ Date of sale _____	Product _____ Model _____ Company _____ Date of sale _____	Product _____ Model _____ Company _____ Date of sale _____
---------------------------------------------------------------------	---------------------------------------------------------------------	---------------------------------------------------------------------



**DAEWOO**  
POWER PRODUCTS



МАГАЗИН МАЙСТОРА®  
БАШ ПРОФЕССИОНАЛЬНЫЕ РЕШЕНИЯ

[www.daewoopowerproducts.com](http://www.daewoopowerproducts.com)

Manufactured under license of Daewoo International Corporation, Korea