

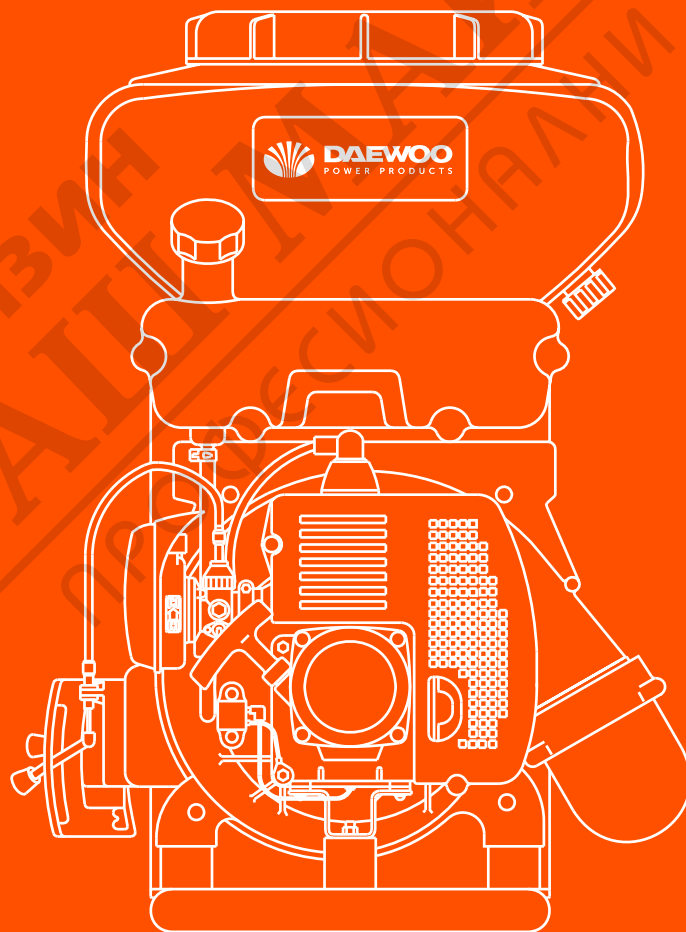

DAEWOO
POWER PRODUCTS

DAGS14-3AH
Gasoline sprayer



USER'S MANUAL

www.daewoopowerproducts.com

Manufactured under license of Daewoo International Corporation, Korea

INDEX

1. TECHNICAL SPECIFICATION	6
2. MAIN APPLICATION	6
3. MAIN FEATURES	6
4. ASSEMBLY FOR VARIETIES OF OPERATING CONDITION	6
5. ROTATION	8
6. MISTING/ DUSTING	10
7. SAFETY	10
8. TROUBLES AND REMEDIES	11
9. TECHNICAL MAINTENANCE AND DEPOSIT FOR A LONG TIME	14
10. EXPLODED VIEW	15
WARRANTY	17

МАГАЗИН МАЙСТОРА
 БАШ МАЙСТОРА®
 ПРОФЕСІОНАЛНИ РЕШЕННЯ

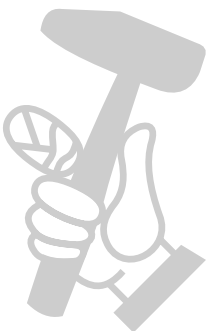

Warning to Users

1. The gasoline engine must use mixed fuel with volume rate of 30:1 for No.90 gasoline to two-stroke automobile oil.
2. 3 to 5 minutes' low speed rotation after start and before stop is very necessary. In order to prevent damage of some parts or body harm caused by violent movement of the engine.
3. high-speed rotation without load must be prohibited! It is strictly prohibited to stop the engine suddenly at high speed.
4. When adding fuel, the engine should stop, fire sources must be far away and smoking is prohibited.
5. In order to avoid electric shock, do not touch the cap of spark plug and the conducting wire during the rotation of the engine.
6. The surface of the muffler and the cylinder is very hot, so neither the hands nor the body approaches them. Especially children should be far away from the engine.

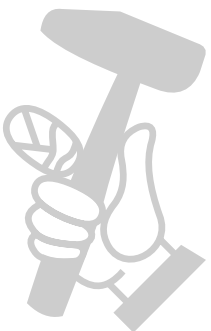

SAFETY PRECAUTION



The use of the machine may be hazardous. The impeller rotating in the volute case may be cut you if you try to touch it. It is important that you read, fully understand the following safety precautions and warning.



Do not lend or rent your sprayer-duster without the Owner's Manual. Be sure that anyone using your sprayer-duster reads and understands the information contained in this manual.

Safe use of a sprayer-duster:

1.The operator

The operator must be in good physical condition and mental health.

Following personnel can't use the machine.

- (1) Mental patients.
- (2) Drunk.
- (3) Under age or old person.
- (4) Person who have just exercised strenuously or slept not enough.
- (5) Tired person or patient and others who can't operate the machine normally.
- (6) Person with no knowledge of the machine.

2.Proper clothing

To reduce the risk of injury, the operator should wear proper protective apparel.

- Clothing and gloves must be wear to avoid contacting pesticide .
- Wear glasses and gauze mask to protect your eye and; Wear the gauze mask to prevent from poisoning
- The machine noise may damage your hearing ,so wear ear muffers to protect your hearing.
- Pay attention to wear a face mask to protect against dust and pesticide.

3.The use of the machine

Starting engine

- (1) Put the dust gate handle to the lowest position before starting the engine, otherwise chemical will be jetted when starting engine.
- (2) Be sure nobody stands in front of nozzle, even though dust gate closed, residual dust in pipe will be blown out.

Spray operation

- (1) It is fine to carry out operation during cool weather with little wind. For example, in the early morning or in the late afternoon. This can reduce the evaporation and drift of chemicals and improve the protecting effect.
- (2) Operator should move windward.
- (3) If your mouth or eyes are spattered with chemicals, wash them with clean water and go to see a doctor.
- (4) If the operator has a headache or dizziness, stop working at once and go to see a doctor in time.
- (5) For the operator's safety, dusting must be carried out strictly according to the instruction of the chemicals and agricultural requirements.
- (6) If you want to stop the engine while dusting, the dust gate must be shut at first..

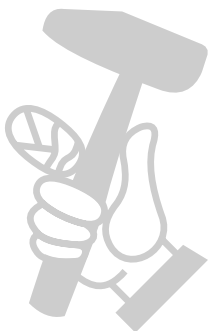

Fueling



Your sprayer-duster uses oil-gasoline mixture. You must avert

- Do not smoke or bring any fire or flame near the fuel or the sprayer-duster.
- Never refuel the machine when it is hot or running.
- Never pour fuel on the machine. If you do, be sure clean them off.

Warning



Never to touch the muffler, spark plug, or other metallic parts of the engine while the engine is in operation or immediately after shutting down the engine. These metallic parts reach high temperatures during operation and doing so could result in serious burns.



After working, wash your hands and clean all of clothing. You know that the remaining pesticide can stain what you touch.

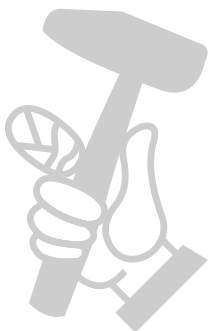

1. Technical Specification

Tank capacity: 14 L

Pressure: 0.02 MPa

Flow: 180 L/h

Horizontal spraying: ≥ 11 m

Droplets mean diameter: ≤ 120 μm

Spray: ≥ 4 kg/min

Dust: ≥ 6 kg/min

ENGINE:

Engine type: Single cylinder, 2 strokes, air cooled.

Displacement: 41.55 cc

Power: 2.13 kW / 7500 rpm

Starting system: Recoil

Stopping system: Fully shutting throttle

Fuel type: Gasoline/ Oil mixture 30:1

Fuel tank capacity: 1.2 L

Oil tank capacity: 1.2 L

Fuel consumption: 1130 g/kWh

N.W.: 10.5 kg

2. Main Application

Our gasoline sprayer DAGS14-3AH is one kind of portable, flexible and efficient machinery for plant protection. It is mainly used in prevention and cure of diseases and pests of plants such as cotton, rice, wheat, fruit trees, tea trees, banana trees, etc. It can also be used for chemical weeding, epidemic prevention, sanitation protection in cities, vegetable protection, etc.

3. Main Features

3.1 This machine adopts gear structure to decrease speed, so it is very durable.

3.2 The main part is the plunger pump of two directions' type. The structure is simple and compact, so it is easy for the maintenance.

3.3 This machine has high pressure, big flow and good efficiency, so the protection effect is very obvious.

3.4 The main spraying parts are three nozzles, which are developed

and only adopted by our factory in our country. So the spraying range is wide.

4. Assembly for varieties of operating condition

(1) Assembly for spraying

a. Remove the tow wing nuts fixed on the chemical tank and take down the tank. Change dusting lid plate for spraying lid plate, then assemble the chemical tank and screw down wing nuts as shown in Fig.1.

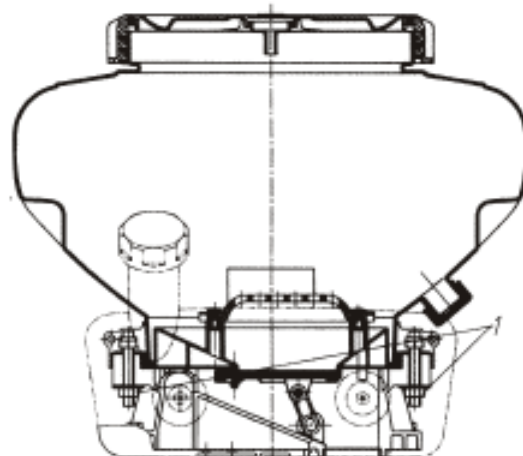

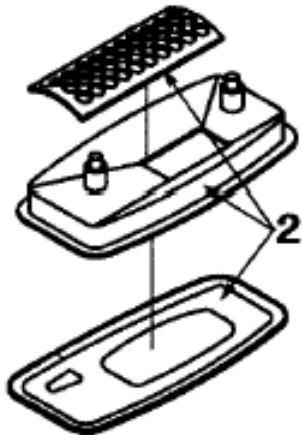

1.Nut 2.Dusting Plate

Fig 1

b.Assembly in chemical tank Remove the lower cover of chemical tank,change into the pressing lid which is connected with rubber tube(do not forget to put on the sealing ring,as Fig.3.).Connect the lid to the rubber tube as shown in Fig.2.

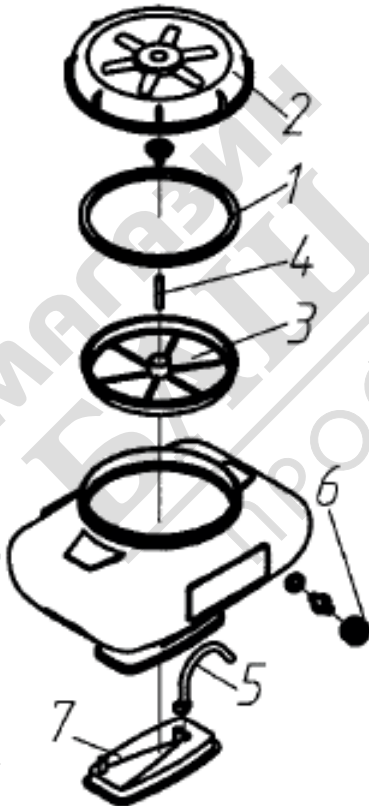

1.Sealing washer 2.Lid 3.Filter net 4.Tube
5.Rubber tube 6.Lower lid 7.Spraying plate

Fig 2

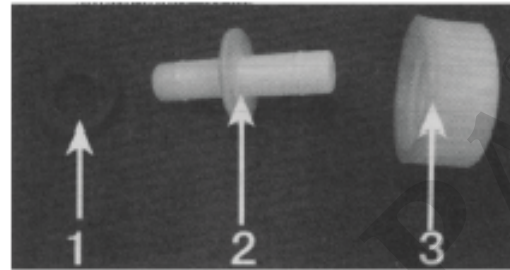
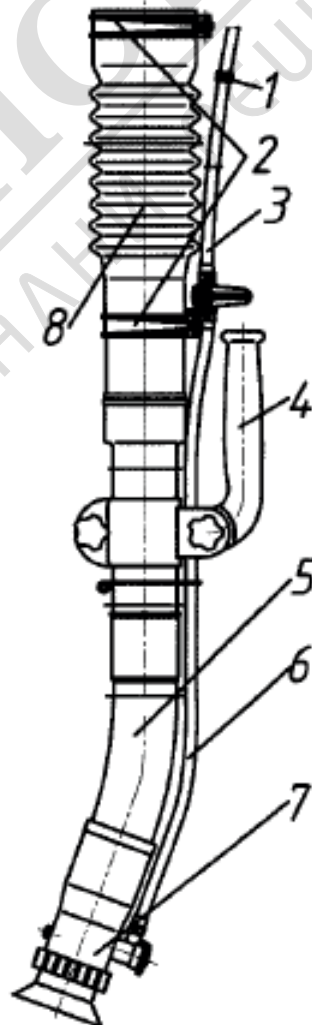

Fig 3

c.Connect spraying pipe to the machine as shown in Fig.4.



1.Clip(A) 2.Clip(B) 3.Plastic tube
4.Handle 5.Bentpipe 6.Plastic pipe
7.Nozzle 8.Hose

Fig 4

(2) Assembly for dusting

Remove the chemical tank, take down the inlet rubber tube, outlet rubber tube, suction strainer, spraying lid plate, pressing lid and union, change for lower lid of chemical tank, then connect the dusting pipe as Fig.5.

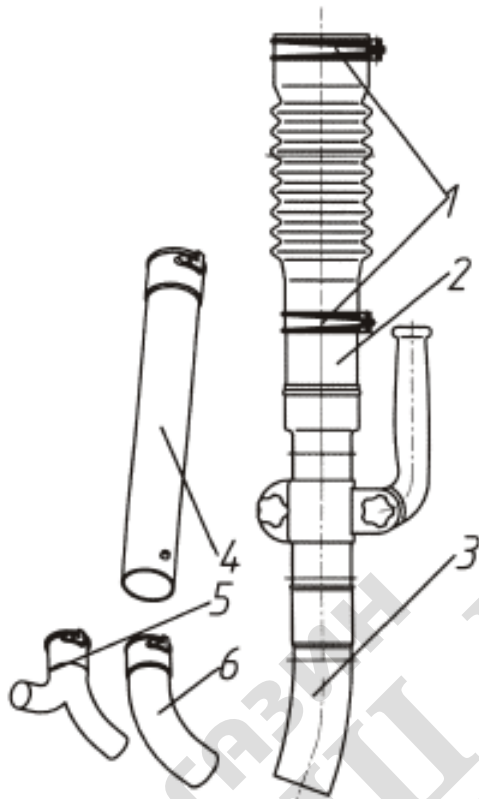

1. Clip 2. Connector 3. Bent pipe
4. Connecting pipe 5. Y-pipe 6. L-pipe

Fig 5

(3) Anti-electrostatic installation

Dusting or spreading granules chemical may cause the electrostatics, that is related to the factors, such as the kind of chemicals, air temperature, air humidity, etc. In order to prevent electrostatics, please use the attachment-insurance chain. When the air becomes dryer, the electrostatic is more serious, in particular when the long membranous tube for dusting and granules spreading is used, electrostatic will often happen. Please pay attention.

One end of insurance chain is inserted into jet pipe, vibrated freely and touched to the ground. Connect another end with conducting wire, then fix conducting wire and insurance chain on bend pipe by screw.

Assembly as Fig.6.



Fig 6

5. Rotation

(1) Check

- a. Checking whether the spark plug and all the connection are tightened.
- b. Checking whether the cooling air channel is clogged. If so, the engine will be over heated.
- c. Checking whether the air filter is dirty. If so, the dirt will reduce the amount of air drawn in. So the engine doesn't run well and waste fuel.
- d. Check whether the gap of the sparking plug is 0.6~0.7mm.
- e. Pull the starter 2 or 3 times, check whether it rotates normally.

(2) Fueling

- a. The fuel for this machine is a mixture of gasoline No.70 or No.90 and 2-stroke oil. The ratio between them is determined by the oil instruction. Incorrect gasoline, oil and mixture may damage the engine.
- b. Never fuel the engine when it is hot or running.
- c. When fuel, never take away the strainer.

(3) Adding chemical

- a. During spraying operation, while adding chemical, the switch must be shut, see Fig.7. During dusting operation, dusting valve throttle and fuel lever should be on the bottom position, otherwise, the machine will have chemical out.

- b. As powder chemical can easily become block, so the chemicals should not be in the chemical tank for a long time.
- c. While spraying, the chemical tank lid should be turned on tightly. After adding powder chemical, please clean the screw of the chemical tank mouth, then turn on the lid tightly.

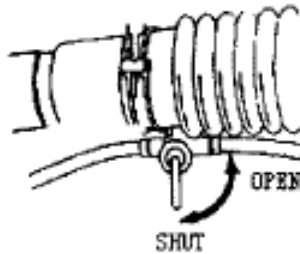
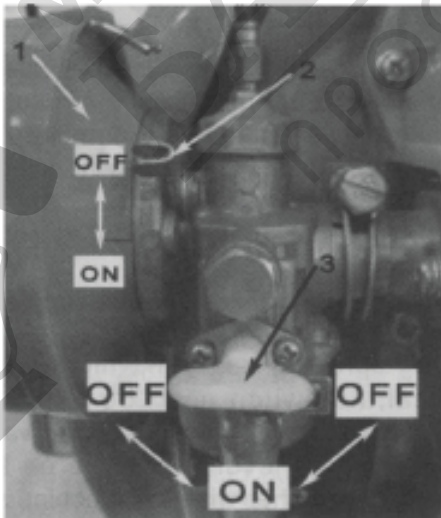

Fig 7

(4) Colding starting

Please operate according to the following procedures:

- Turn on the fuel switch, see Fig 8.
- Put the fuel lever on the starting position.
- Put the choker on the full position.
- Pull the starter for a few times and have it returned slowly. Do not leave the handle to return freely to avoid the damage of the starter.
- Close the choker and pull starter handle until the engine fires.
- After starting the engine, open choker fully.
- Let the engine run at low speed for 2-3 minutes, then start the spraying or dusting operation.



- Air filter
- Choke handle
- Fuel switch

Fig 8

(5) Starting the warm engine

- Leave the choker fully open.
- If the engine draws in too much fuel, leave the fuel switch fully close, pull the starter 5-6 times. Then start the engine as above.

(6) Speed adjustment

Speed does not meet the fixed number with the fuel lever at the working position or the engine can not stop with the handle at the lowest position. Regulate as the following.

- Loosen the lock nut.
- Turn the regulating screw right to decrease the speed. Otherwise, to increase the speed.
- After adjustment is finished, tighten the lock nut.

See Fig.9.

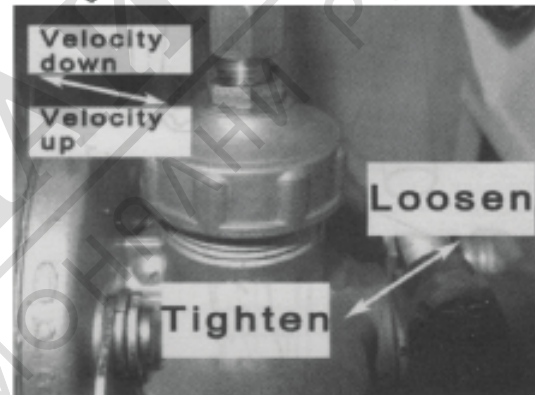

Fig 9

(7) Stopping the engine

- During misting operation turn off the chemical switch first, then stop the machine.
- During dusting operation, put the fuel lever and dusting lever at the close position.
- After finish work, turn off the fuel switch in order to avoid difficult start next time.

Note: While the engine is running, the hose must be mounted to the machine, otherwise, cooling air will be reduced and the engine may be damaged.

6. Misting/Dusting

(1) Misting. Loosen the pressing lid, regulate the length of the nozzle opening to meet the different requirements of misting. Turn the regulating valve to change the amount of misting. See Fig.10.

Opening	Discharging(L/min)
1	1
2	1.5
3	2
4	3

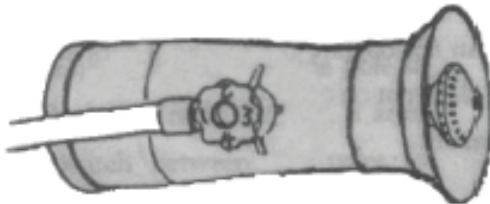

Fig 10

(2) Dusting. Regulate the discharge by shifting the dust rod's position in the three holes of the rock-arm. See Fig.11 and Fig.12.

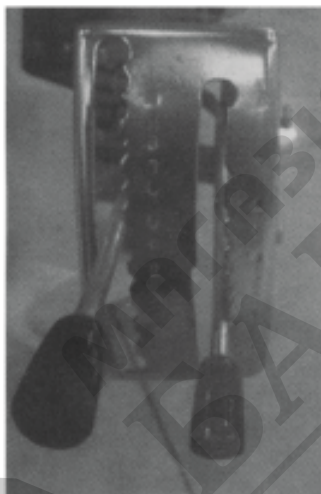

Fig 11

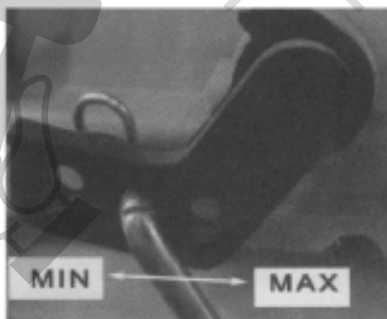

Fig 12

7. Safety

(1) Read this manual carefully. Be sure you understand how to operate this machine properly before you use it.

(2) Protective clothing (Fig.13)

- Wear flanged cap.
- Wear dirt/fog-proof glasses.
- Wear gauze mask.
- Wear long gloves.
- Wear coat guarding against poisons.
- Wear boots.

(3) Following personnel can not use the machine.

- Mental patients.
- Drunk.
- Under age or old person.
- Person with no knowledge of the machine.
- Dog-tired person or patient and others who can not operate the machine normally.
- Person who have just exercised strenuously or slept not enough.
- Women giving the breast to baby or being pregnant.

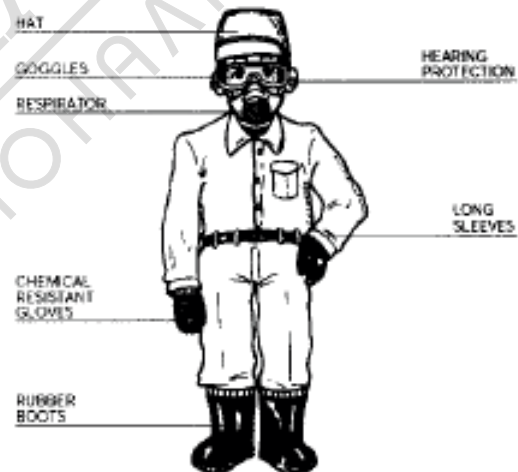

Fig 13

(4) Avert fire

- Do not fire or smoke nearby the machine.
- Never refuel the machine when it is hot or running.
- Never pour fuel on the machine when it is hot or running.
- Always tighten the fuel tank lid.
- Always move at least 10 feet away from the fuel container before starting the machine.

(5) Starting engine (Fig 14)

a. Put the dust gate handle to the lowest position before starting the engine, otherwise chemicals will be jetted when starting engine.

b. It is prohibited to stand in front of nozzle. Even though dust gates are closed, residual dust in pipe will be blown out.

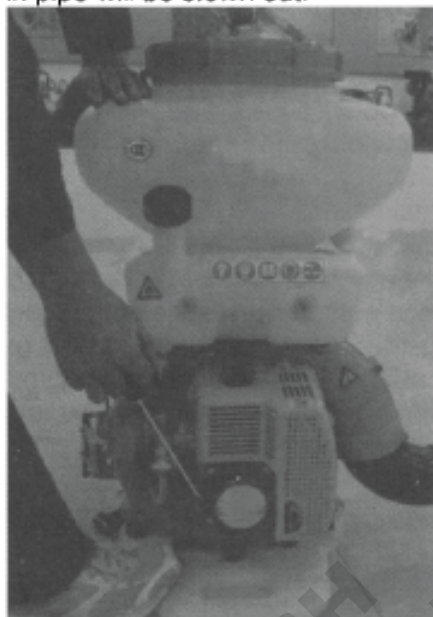

Fig 14

(6) Misting/Dusting

a. It is fine to carry out operation during cool weather with little wind. For example, in the early morning or in the late afternoon, this can reduce the evaporation and drift of chemicals and improve the protecting effect.

b. Operator should move windward.

c. Review area to be cleared. Look for potential hazards such as stones or metal objects. Spectators and fellow workers must be warned, and children and animals prevented from coming nearer than 15m while the blower is in use. Do not point the blowy pipe at people or animals.

d. If your mouth or eyes are spattered with chemicals, wash them with clean water and then go to see the doctor.

e. If the operator has a headache or dizziness, stop working at once and go to see a doctor in time.

f. For the operator's safety, misting/dusting must be carried out strictly according to the

instruction of the chemicals and agricultural requirements.

8. Troubles and Remedies

(1) Engine starts difficultly or can not start. Check if the sparking plug has sparked-over. Screw down the sparking plug, put the side pole to touch the cylinder. Pull the starter and watch between the poles of sparking plug whether there are sparks. Pull the starter carefully, do not touch the metal part of sparking plug for prevention of getting an electric shock as shown in Fig. 15.



Fig 15

TROUBLE		CAUSE	REMEDY
No flash	Spark plug	1.Poles wet	Dry it
		2.Covered with carbon	Clean the carbon
		3.The insulation damaged	Replace
		4.Spark gap incorrect	Adjust 0.6~0.7mm
		5.The poles burned	Replace
	Magneto	1.The wrap of wire damaged.	Remedy or replace
		2.Insulation of coil bad	Replace
		3.The wire of coil broken.	Replace
4.The electronic firing unit defective		Replace	
Normal	Compression ratio and fueling well	1.Too much fuel in cylinder	Drain
		2.Water or dirt in fuel	Replace
	Fueling well but compression ratio bad.	1.Cylinder and piston ring wore or tore	Replace them
		2.The plug loose	Tighten it
	Carburetor not fueling	1.No fuel in tank	Fuel
		2.Fileter gauze clogged	Clean
	3.The air hole of the tank clogged	Clean	

(2)Engine lacks power

TROUBLE	CAUSE	REMEDY
The compression ratio is fine	1. The filter plate clogged	Clean
	2.Air passes through the connection of carburetor	Tighten
	3.Engine overheat	Stop the engine and cool it
	4.Water in fuel	Refill with fresh fuel
	5.The carbon clogs muffler	Clean
Engine overheats	1.Mixed gas (fuel) thin	Adjust the carburetor.
	2.Cylinder covered with carbon	Clean
	3.Oil bad	Use 2-T engine oil and adjust the mix ration.
	4.No connection with hose	Correctly assemble the machine
Engine noisy or knocking	1.Fuel bad	Replace
	2.Carbon in cylinder	Clean
	3.The running parts wore and tore.	Check and replace

(3)Engine stops while running

TROUBLE	CAUSE	REMEDY
Engine stops suddenly	1.The lead wire of plug loose	Replace firmly
	2.Piston bitten	Change or remedy
	3.Plug covered with carbon	Clean plug
	4.Fuel used up	Fill the fuel tank
The engine stops slowly	1.Carburetter clogged	Clean
	2.The air hole in the tank clogged	Clean
	3.Water in fuel	Refill with fresh fuel

(4) Engine hard to stop

TROUBLE	CAUSE	REMEDY
Throttle handle put to the lowest position, the engine still runs .	The throttle cord is short or piston of carburetter blocked.	Adjust the cord or remedy the carburetter.

(5) Dusting

TROUBLE	CAUSE	REMEDY
No dust discharge or discharge intermittently	1.The dust gate can not be opened.	Adjust the pull rod of the dust gate
	2.The tank lid not tightened	Tighten the tank lid
	3.The dust or granule mix with foreign body.	Clean it
	4.The dust or granule lumped.	Break the lump
	5.Wet dust or granule	Dry it
	6.The granules is too big	Change the granules
The dust gate not work properly	1.The dust gate can't closed	Clean it
	2.The dust gate clogged by foreign matter	Tighten it
Leakage of dust	1.the clamp ¹⁰ plate of the chemical tank bottom loosened	Tight it
	2.The sealing gasket of the dusting lid damaged	Change it with new one
	3.The O-sealing ring of the elbow damaged	Change it with new one
The discharge rate out of control	The control device of dust gate not work properly	Remedy it

(6) Spraying

TROUBLE	CAUSE	REMEDY
No spray mixture jet or jet intermittently	1.Nozzle switch or control valve clogged	Clean
	2.Liquid lead pipe clogged.	Clean it
	3.No pressure or the pressure is lower	Tighten the tank lid and screw down the two wing nuts.
Spray mixture leakage	1.The spraying lid plate fitted incorrect	Refit it
	2.Every threaded joint loosened	Screw down it

9. Technical Maintenance and Deposit for a Long Time

(1) Spraying units

- Clean out any residual spray mixture or dust in the chemical tank and all other parts after operation with clean water and dry it.
- Clean the dust gate and chemical tank inside and outside after dusting.
- Loosen the chemical tank lid while the machine free.
- Let the machine run at a low speed 2-3 minutes after cleaning.

(2) Fuel system maintenance

- Water or dirt in fuel is one of the main cause of the engine trouble, clean the fuel system regularly.
- Residual fuel remaining in the fuel tank and carburetor for long time will gum and clog the fuel system, thus cause the engine not to working properly. So all of the fuel should be discharged if the machine isn't used after one week.

(3) Air filter and plug.

- Clean the filter after every day operation. Dirt adhering to sponge reduces the engine power.
- Dry filter before reinstalling.
- Clean stains or carbon off the spark plug and adjust spark gap to 0.6~0.7mm.
- The plug model of this machine is 4106J. Do not use other models. If it is necessary for change, may buy it from local agricultural department or plant protection department, as shown in Fig.16.

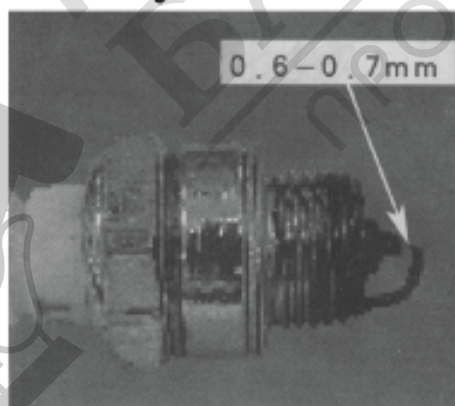

Fig 16

Note:

a) The work including maintenance, cleaning and adjusting must be done after stopping the machine and out of the danger range.

b) When maintenance, the discharge spout can't be award to the maintenance man.

c) Please periodic check the braces situation. Without delay replace the worn-out braces.

(4) Long time storage

- Clean the machine and apply antirust oil to metal parts.
- Remove the spark plug and pour 15~20g of 2-stroke engine oil into the cylinder through the spark plug pole. Pull the starter handle 4~5 times to distribute the oil inside the engine. Pull the handle slowly until the piston reaches the top of its travel and leave it there, then install the spark plug.
- Remove the chemical tank, clean the dust gate and inside and outside of chemical tank, then install the tank and leave the lid loose.
- Remove spray units and clean them. Store by themselves.
- Discharge fuel in the tank and carburetor entirely.
- Cover the machine with plastic dustcoat and store it in a dry and clean place.

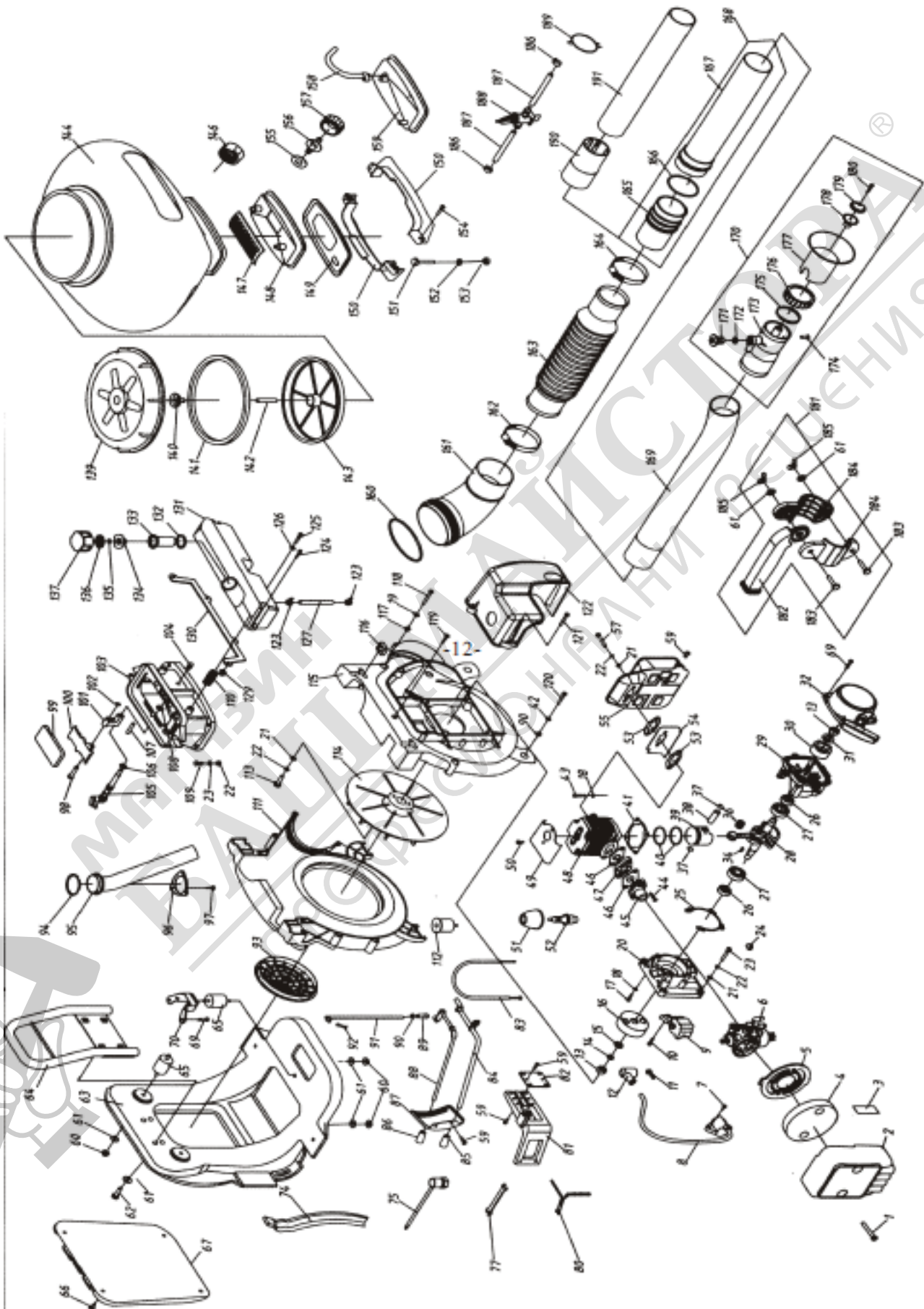

Ser.No.	Part Name	Ser.No.	Part Name	Ser.No.	Part Name	Ser.No.	Part Name	Ser.No.	Part Name	Ser.No.	Part Name
1	screw assem	31	washer	65	rubber pillar	102	ring	133	filter	165	connector
2	outside cover	32	starter	66	nylon clip	103	shutter	134	rubber lid	166	sealing washer
3	sign	34	key	67	back mat	104	plug	135	filter net	167	pipe
4	filter	36	bearing	69	screw assem	105	rocker shaft	136	plastic lid	168	connector assem
5	back plate	37	ring	70	support	106	sealing washer	137	fuel tank lid	169	long bend pipe
6	carburettor	38	piston pin	74	belt component	107	pin	139	lid	170	nozzle assem
7	screw	39	piston	75	spanner	108	ring	140	air valve	171	valve
8	winding	40	piston ring	77	spanner	109	bolt	141	sealing washer	172	sealing washer
9	winding	41	sealing washer	80	insurance chain	110	fuel tank support	142	tube	173	shot pipe
10	screw assem	42	washer	81	support frame	111	volute case	143	filter	174	screw
11	spring	43	screw	82	plate	112	rubber pillar	144	chemical tank	175	sealing washer
12	cap	44	screw assem	83	throttle rope	113	bolt	146	lid	176	lid
13	M10×1 nut	45	flange	84	throttle rod	114	impeller	147	plate	177	nozzle
14	washer	46	gasket	85	handle	115	volute case	148	dusting plate	178	nozzle piece
15	washer	47	insulator	86	handle	116	nut	149	sealing washer	179	nozzle piece
16	rotor	48	cylinder	87	graduator	117	nut	150	clamp	180	screw
17	screw	49	cover	88	dust rod	118	long screw	151	bolt	181	handle assem
18	washer	50	screw assem	89	connector	119	screw	152	washer	182	handle
19	washer	51	cap	90	nut	120	screw	153	nut	183	bolt
20	front crankcase	52	spark plug	91	pulling rod	121	screw assem	154	screw assem	184	clamp
21	washer	53	gasket	92	spanner	122	protection	155	sealing washer	185	nut
22	washer	54	gasket	93	net cover	123	clip	156	link pipe	186	clip
23	screw	55	muffle	94	washer	124	screw	157	connector lid	187	tube
24	fixity	57	screw	95	pipe	125	screw	158	tube	188	cock assem
25	sealing washer	59	screw assem	96	lid	126	washer	159	misting plate	189	clamp
26	seal	60	nut	97	screw	127	tube	160	sealing washer	190	guide pipe
27	bearing	61	washer	98	pin	129	nut	161	bend pipe	191	connect pipe
28	crankshaft	62	screw	99	rubber plate	130	support frame	162	clip		
29	back crankcase	63	frame	100	slide	131	fuel tank	163	hose		
30	ratchet	64	belt frame	101	support arm	132	sealing washer	164	clip		

WARRANTY CARD

Product model	Date of sale
Serial number	Company
Username	Client's signature

The product is in good conditions and fully complete. Read and agree the terms of the warranty.

GUARANTEE

The warranty period starts from the date of sale of the products and covers 2 years for all power products.

During the warranty period, free failures caused due to the use of poor-quality materials in the production and manufacturer workmanship admitted fault are removed. The guarantee comes into force only when warranty card and cutting coupons are properly filled. The product is accepted for repair in its pure form and full completeness.

WARRANTY DOES NOT COVER

- Mechanical damage (cracks, chips, etc.) and damage caused by exposure to aggressive media, foreign objects inside the unit and air vents, as well as for damage occurred as a result of improper storage (corrosion of metal parts);
- Failures caused by overloading or product misuse, use of the product for other purposes. A sure sign of overload products is melting or discoloration of parts due to the high temperature, simultaneous failure of two or more nodes, teaser on the surfaces of the cylinder and the piston or destruction of piston rings. Also, the warranty does not cover failure of the automatic voltage regulator due to incorrect operation;
- Failure caused by clogging of the fuel and cooling systems;
- Wearing parts (carbon brushes, belts, rubber seals, oil seals, shock absorbers, springs, clutches, spark plugs, mufflers, nozzles, pulleys, guide rollers, cables, recoil starter, chucks, collets, removable batteries, filters and safety elements, grease, removable devices, equipment, knives, drills, etc.);
- Electrical cables with mechanical and thermal damage;
- Product opened or repaired by a non-authorized service center.
- Prevention, care products (cleaning, washing, lubrication, etc.), installation and configuration of the product;
- Natural wear products (production share);
- Failures caused by using the product for the needs related to business activities;
- If the warranty card is empty or missing seal (stamp) of the Seller;
- The absence of the holder's signature on the warranty card.

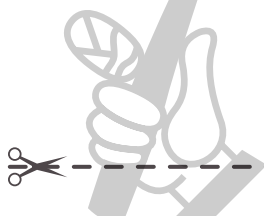

DAEWOO	DAEWOO	DAEWOO
Product _____	Product _____	Product _____
Model _____	Model _____	Model _____
Company _____	Company _____	Company _____
Date of sale _____	Date of sale _____	Date of sale _____



DAEWOO

POWER PRODUCTS

МАГАЗИН МАЙСТОРА®
БАШ ПРОФЕССИОНАЛЬНЫЕ РЕШЕНИЯ



www.daewoopowerproducts.com

Manufactured under license of **Daewoo International Corporation**, Korea