



DAEWOO
POWER PRODUCTS

DIRECT AIR COMPRESSOR SERIES



USER'S MANUAL

www.daewoopowerproducts.com

Manufactured under license of Daewoo International Corporation, Korea

INDEX

1. PREPARATION FOR STARTING	2
2. SAFETY GUIDELINES	2
3. WARNING	2
4. CAUTION	3
5. APPLICATION	3
6. GENERAL VIEW AND MAIN COMPONENTS	4
7. TECHNICAL SPECIFICATIONS	5
8. SPARE PARTS LIST	6
9. THINGS TO DO THE FIRST TIME	8
10. OPERATION AND MAINTENANCE	11
11. TROUBLES AND REMEDIES LIST OF GOODS	12
WARRANTY	13

МАГАЗИН МАЙСТОРА
 БАШ МАЙСТОРА®
 ПРОФЕСІОНАЛНИ РЕШЕННЯ

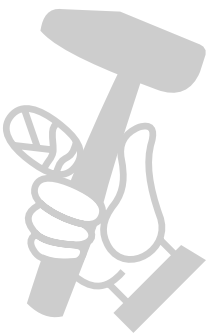

1. PREPARATION FOR STARTING

- (1) Air compressor should be placed in a clean, dry and ventilated area.
- (2) In order to extend compressor lifespan ,reduce heat for moving parts by making sure this air compressor cover must be at least 0.3~0.5 meters away from the wall.
- (3) Keep voltage within $\pm 5\%$ of rating
- (4) Keep the oil level in the red circle leveler.
- (5) Recommend compressor oil SAE30 or L-DAB 100 when temperature above 10°C, SAE10 or L-DAB68 when temperature below 10°C.
- (6) The normal temperature of working enviroment should be -5°C~35°C, and the altitude of the working place should be 2000m below.
- (7) The normal temperaure of compressor body is 180°C and the lubricating oil in the crankcase is less than 70°C when the compressor is working.
- (8) Open outlet valve and let air compressor compressor run 10 minutes without load before regular operation

2. SAFETY GUIDELINES

DANGER-AN IMMEDIATE HAZARD THAT WILL CAUSE SERIOUS INJURY OR LOSS OF LIFE

(1).To reduce the risk of fire or explosion ,never spray flammable liquids in a confined area . It is normal pressure switch to produce sparks while operating. If sparks come into contact with vapors from gasoline or other solvents, they, may ignite causing fire or explosion, Always operate the compressor in a well-ventilated area, Do not smoke while spraying. Do not spray where sparks or flame are present, Keep compressor as far from spray area as possible.

(2).The solvents Trichloroethane and Methylene Chloride can chemically react with aluminum used in paint spray guns, paint pumps, etc, and cause an explosion, If you are using these solvents, use only stainless steel spray equipment, This does not affect your air compressor, but many affect the equipment being used.

(3).Never directly use the compressed air produced by a compressor. It is not suitable for breathing purposes.

3. WARNING-A POTENTIAL HAZARD THAT COULD CAUSE SERIOUS INJURY OR LOSS OF LIFE.

(1).Do not weld on the air tank of this compressor. Welding on the air compressor tank strength and cause an extremely hazardous condition. Welding on the tank in any manner will void the warranty

(2).Never use an electric air compressor outdoors when it is raining or on a wet surface, as it may cause an electric shock.

(3).This unit starts automatically. Always shut off the compressor, remove the plug from the outlet, and emptying all pressure from the system before servicing the compressor, and when the compressor is not in use.

(4).Check the manufacturer's maximum pressure rating for air tools and accessories. Compressor outlet pressure must be regulated so as to never exceed the maximum pressure rating of the tool.

(5).High temperatures and moving parts are present under the protection cover. To prevent burns or other injuries, Do not operate with the protection cover removed. Do not allow the compressor parts to cool before handling or servicing.

(6).Be certain to read all labels when you are spraying paints or toxic materials and follow the safety instructions. Use a respirator mask if there is a chance of inhaling anything you are spraying, Read all instructions and be sure that your respirator mask will protect you.

(7).Always wear safety goggles or glasses when using an air compressor. Never point any nozzle or sprayer toward a person or any part of the body.

(8).Do not adjust the pressure switch or relief valve for any reason, Doing so voids all warranties, They have been preset at the factory for the maximum pressure of this unit.

4.CAUTION-A POTENTIAL HAZARD THAT MAY CAUSE MODERATE INJURY OR DAMAGE TO EQUIPMENT.

(1).Drain the moisture from the tank on a daily basis. A clean, dry tank will help prevent corrosion.

(2).Pull the pressure relief valve ring daily to ensure that the valve is functioning properly, and to clear the valve of any possible obstructions.

(3).To provide proper ventilation for cooling, the compressor must be kept a minimum of 31cm(12 inches) from the nearest wall, in a well-ventilated area.

(4).Fasten the compressor down securely if transporting is necessary, Pressure must be released from the tank before transporting

(5).Protect the air hose and electric cord from damage and puncture. Inspect them weekly for weak or worn spots and replace if necessary.

5.APPLICATION

The compressors are widely used in various pneumatic tools and machinery of communication, machinery manufacture, medical and health, garments, spinning and weaving works, such as tyre, gas-filled, painting etc.

6. GENERAL VIEW AND MAIN COMPONENTS

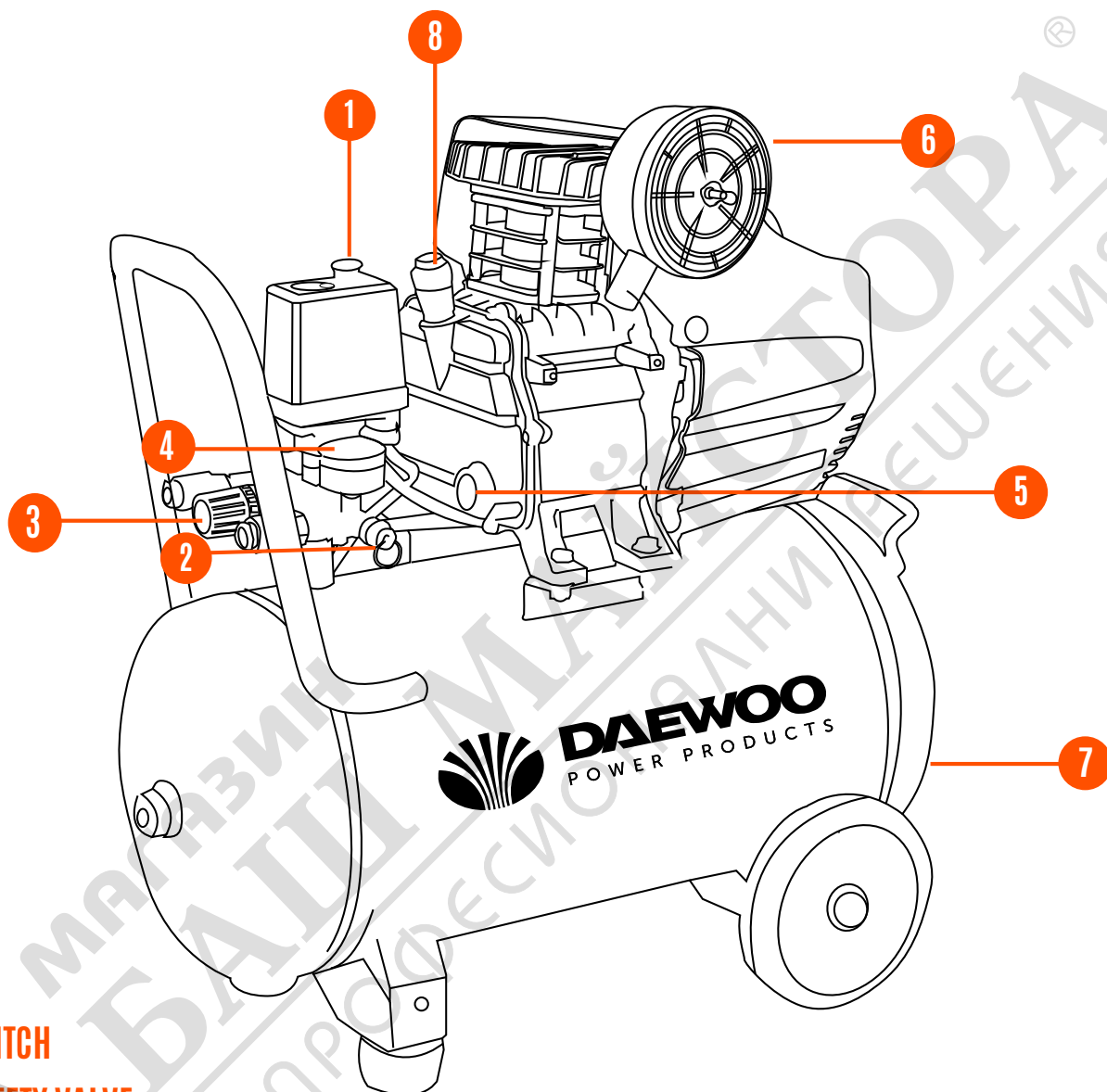

1. SWITCH
2. SAFETY VALVE
3. REGULATOR
4. GAUGE
5. OIL WINDOW
6. AIR FILTER
7. DRAIN COCK
8. BREATH PIPE

7. TECHNICAL SPECIFICATIONS

DAAC24DN

Power: 2 hp/1.5 kW
Tank capacity: 24 L
Cylinders: 1*42 mm/1*47 mm
Air filter type: 3/8" Plastic
Pressure: 8 bar/115 psi
Engine speed: 2850 rpm(50 Hz)/
3450 rpm(60 Hz)
Flow: 135 L/min(1*42mm)/
169 L/min(1*47mm)
Noise: 84 dB

DAAC50DN

Power: 2hp/1.5 kW
Tank capacity: 50 L
Cylinders: 1*42 / 1*47 mm
Air filter type: 3/8" Plastic
Pressure: 8 bar/115 psi
Engine speed: 2850 rpm(50 Hz)/
3450 rpm(60 Hz)
Flow: 135 L/min(42 mm) 169 L/min(47 mm)
Noise: 89 dB

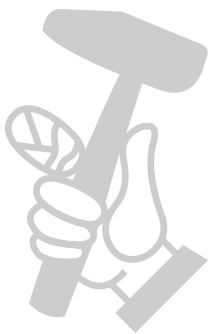

МАГАЗИН МАЙСТОРА
БАШ МАЙСТОРА®
ПРОФЕСИОНАЛНИ РЕШЕНИЯ

8. SPARE PARTS LIST

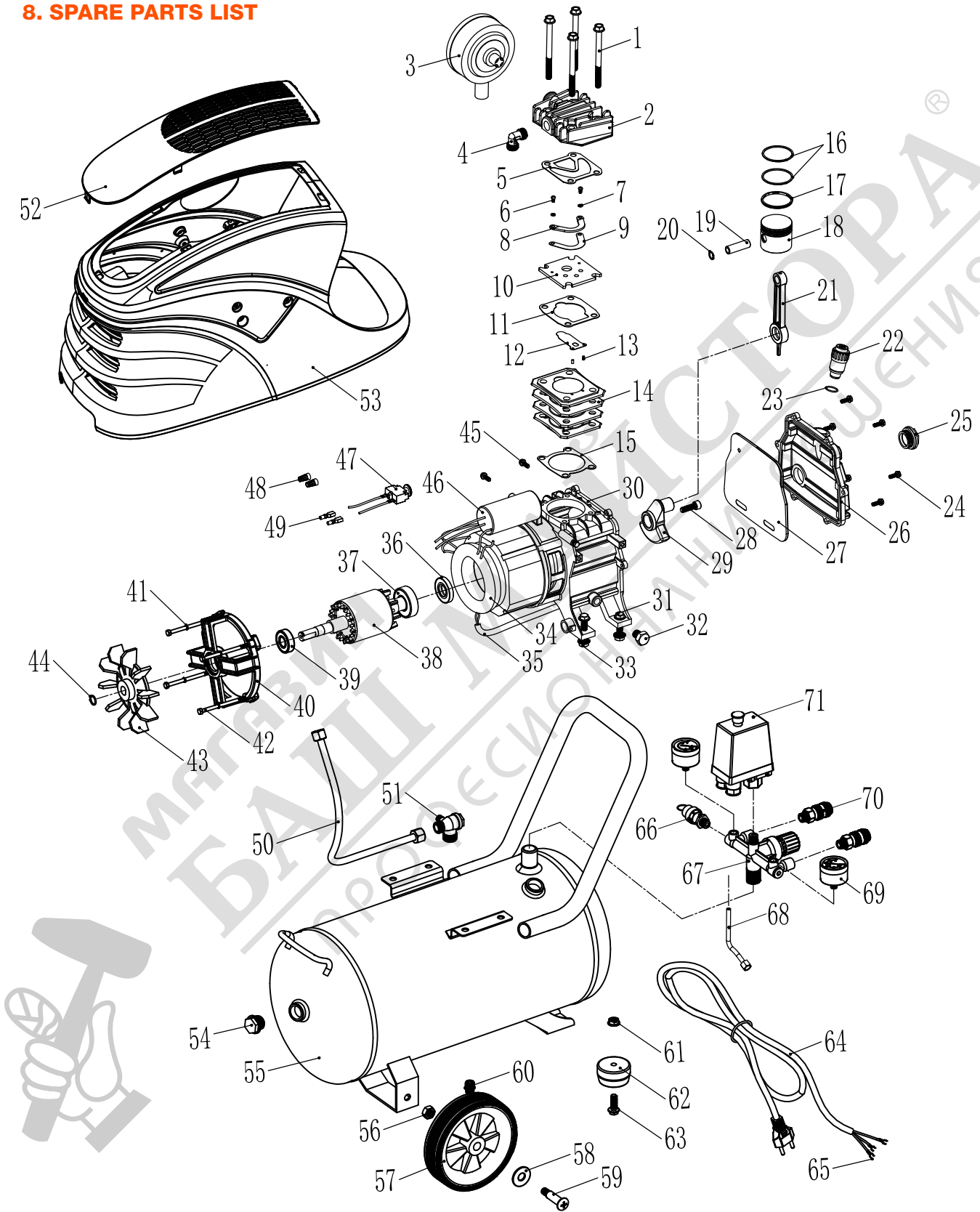

NO	Name	Quinty	Uint	NO	Name	Quinty	Uint
1	Bolt	4	PCS	37	Bearing	1	PC
2	Cylinder head	1	PC	38	Rotor	1	PC
3	Air filter	1	PC	39	Bearing	1	PC
4	Exhaust elbow	1	PC	40	Rear motor cover	1	PC
5	Cylinder head gasket	1	PC	41	Spring washer	4	PCS
6	Bolt	2	PCS	42	Bolt	4	PCS
7	Lock washer	2	PCS	43	Fan	1	PC
8	Valve limiter	1	PC	44	Snap spring	1	PC
9	Valve reed	1	PC	45	Bolt	6	PCS
10	Valve plate	1	PC	46	Capacitor	1	PC
11	Valve plate gasket	1	PC	47	Protector	1	PC
12	Intake valve sheet	1	PC	48	Terminal cap	4	PCS
13	Position pin	2	PCS	49	Insulating sheath	2	PCS
14	Cylinder	1	PC	50	Exhaust pipe group	1	PC
15	Cylinder gasket	1	PC	51	Check valve	1	PC
16	Compression ring	2	PCS	52	Housing cover	1	PCS
17	Oil ring	1	PC	53	Housing bottom	1	PCS
18	Piston	1	PC	54	Check hole connector	2	PCS
19	Piston pin	1	PC	55	Tank	1	PC
20	Snap spring	2	PCS	56	Nut	2	PCS
21	Connecting rod	1	PC	57	Wheel	2	PCS
22	Breath pipe	1	PC	58	Plain washers	2	PCS
23	"O" Ring	1	PC	59	Axle	2	PCS
24	Bolt	6	PCS	60	Dain valve	1	PC
25	Oil leveler	1	PC	61	Nut	1	PC
26	Crankcase cover	1	PC	62	Foot pad	1	PC
27	Cover seal	1	PC	63	Bolt	1	PC
28	Bolt	1	PC	64	Power cord	1	PC
29	Crank	1	PC	65	Terminal	6	PCS
30	Crankcase	1	PC	66	Safety valve	1	PC
31	Bolt	4	PCS	67	Regulator valve	1	PC
32	Bolt	4	PCS	68	Release pipe	1	PC
33	Nut	1	PC	69	Pressure gauge	2	PCS
34	Stator	4	PCS	70	Quick connector	2	PCS
35	Cable	1	PC	71	Pressure switch	1	PC
36	Oil seal	1	PC				

9. THINGS TO DO FOR THE FIRST TIME

(1) Connect the wheel to the air compressor.



(2) Use screwdriver to tight the axle



(3) Install the Rubber foot pad to the air compressor.



(4) Remove the Warning Sign and oil plug



(5) Add the oil



Oil must be add until the red point



(6) Install the breath pipe into the hole of the crankcase cover



(7) Install the Air Filter into the compressor head.



(8) Connect the power

(9) Pull up the red knob of pressure switch in position on



10. OPERATION AND MAINTENANCE

- (1).Please check the technical documents carefully after you opened the case(documents including introduction manual) Check if the spare parts are correct, and check if the compressor is in good condition.
- (2).Pull out the oil plug, filling N32 machine lubricating oil to the oil hole till the stipuiated level in winter. While in summer using N68 machine lubricating oil. Then insert breath pipe , Plug in the power cord and operate the compressor without load, check if it operates properly.
- (3).Conneting to the pncumatic tools, starting the compressor, then you can use tools. Note: The compressor should be started without any working pressure.
- (4).The compressor uses machine lubricating oil, Please filling oil before operating. During operation the oil, temperature must be below 70 (use N32in winter and N68 in summer).
- (5).After 500 hours operation, replace the oil, And disassemble crankcase end cover, clean the old oil and dirty things. Then reassemble the crankcase end cover, fill fresh oil.
- (6).Usually clean air filter once a week.
- (7).After operation 16 hours open drain valve under tank, drain the water from the tank, Clean tank once a half year.
- (8)Clean crankcase every 120 working hours,and check safety valve and pressure gauge.
- (9).After each use, turn off the power. drain all the pressure from the tank.
- (10).Maintaining the compressor normally, Disassemble the compressor. Then using light oil, such as gasoline, clean all the parts, And drying them, during assembling, smear grease on the touching surfaces. If necessary repair or replace worn parts. Assemble and adjust the parts correctly. Note: Electric units should be grounded correctly.
- (11).If the compressor stop using for a long period, air vaives and touching surface should be cleaned and smeared with grease.

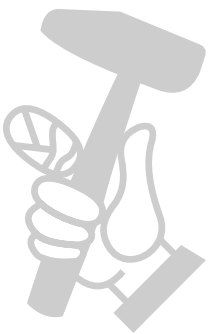

11. TROUBLES AND REMEDIES LIST OF GOODS

PROBLEM	POSSIBLE CAUSE(S)	CORRECTIVE ACTION
Compressor will not run	<ol style="list-style-type: none"> 1.No electrical power 2.Blown fuse 3.Breaker open 4.Thermal overload open 5.Pressure switch bad 	<ol style="list-style-type: none"> 1.Plugged in? Check fuse/breaker 2.Replace blown fuse. 3.Reset determining why problem Happened 4.Motor will restart when cool (approx. 15minutes). 5.Contact Authorized Service Center
Motor hums but cannot run or runs slowly	<ol style="list-style-type: none"> 1.Low voltage 2.Shorted or open motor winding 3.Defective check valve or pressure switch 4.Compressed air in cylinder 	<ol style="list-style-type: none"> 1.Check with voltmeter(105v.min) 2.Contact Authorized Service Center 3.Contact Authorized Service Center 4.Turn the AUTO? OFF switch to the OFF position for 15 sec. then turn to the AUTO position
Fuses blow/circuit breaker trips repeatedly CAUTION!! NEVER USE AN EXTENSION CORD WITH THIS PRODUCT!	<ol style="list-style-type: none"> 1.Incorrect size fuse circuit overloaded 2.Defective check valve or pressure switch 	<ol style="list-style-type: none"> 1.Check for proper fuse. Use timedelay fuse. Disconnect from other electrical appliances from circuit or operate compressor on its own branch circuit 2.Contact Authorized Service Center
Thermal overload protector Cuts out repeatedly	<ol style="list-style-type: none"> 1.Low voltage 2.Clogged air filter 3.Lack of proper ventilation/room temperature too high 	<ol style="list-style-type: none"> 1.Check with voltmeter(105v.min) 2.Clean filter(see Maintenance section). 3.Move compressor to well ventilated area.
Tank pressure drops when compressor shuts off	<ol style="list-style-type: none"> 1.Loose connections(fittings tubing. etc) 2.Open draincock. 3.Check valve leaking 	<ol style="list-style-type: none"> 1.Check for air leaks. Use sealing tape on all leaking connections. 2.Tighten draincock. 3.Disassemble check valve assembly. Clean or replace. <p>DANGER!! DO NOT DISASSEMBLE CHECK VALVE WITH AIR IN TANK BLEED TANK FIRST</p>
Excessive moisture in discharge air	<ol style="list-style-type: none"> 1.Excessive water in tank 2.High humidity 3.Clogged intake filter 	<ol style="list-style-type: none"> 1.Drain receiver 2.Move compressor to area of less humidity: use air line filter 3.Clean or replace filter
Compressor runs continually	<ol style="list-style-type: none"> 1.Defective pressure switch 2.Excessive air usage 	<ol style="list-style-type: none"> 1.Replace switch 2.Compressor not large enough to meet CFM requirement or the air tool
Compressor vibrates.	<ol style="list-style-type: none"> 1.Loose mounting bolts 2.Rubber tank feel worn/missing 	<ol style="list-style-type: none"> 1.Tighten 2.Replace
Air output lower than normal	<ol style="list-style-type: none"> 1.Open draincock 2.Intake filter dirty 3.Connection leaking 	<ol style="list-style-type: none"> 1.Tighten draincock 2.Clean or replace intake filter 3.Tighten connections

WARRANTY CARD

Product model	Date of sale
Serial number	Company
Username	Client's signature

The product is in good conditions and fully complete. Read and agree the terms of the warranty.

GUARANTEE

The warranty period starts from the date of sale of the products and covers 2 years for all power products.

During the warranty period, free failures caused due to the use of poor-quality materials in the production and manufacturer workmanship admitted fault are removed. The guarantee comes into force only when warranty card and cutting coupons are properly filled. The product is accepted for repair in its pure form and full completeness.

WARRANTY DOES NOT COVER

- Mechanical damage (cracks, chips, etc.) and damage caused by exposure to aggressive media, foreign objects inside the unit and air vents, as well as for damage occurred as a result of improper storage (corrosion of metal parts);
- Failures caused by overloading or product misuse, use of the product for other purposes. A sure sign of overload products is melting or discoloration of parts due to the high temperature, simultaneous failure of two or more nodes, teaser on the surfaces of the cylinder and the piston or destruction of piston rings. Also, the warranty does not cover failure of the automatic voltage regulator due to incorrect operation;
- Failure caused by clogging of the fuel and cooling systems;
- Wearing parts (carbon brushes, belts, rubber seals, oil seals, shock absorbers, springs, clutches, spark plugs, mufflers, nozzles, pulleys, guide rollers, cables, recoil starter, chucks, collets, removable batteries, filters and safety elements, grease, removable devices, equipment, knives, drills, etc.);
- Electrical cables with mechanical and thermal damage;
- Product opened or repaired by a non-authorized service center.
- Prevention, care products (cleaning, washing, lubrication, etc.), installation and configuration of the product;
- Natural wear products (production share);
- Failures caused by using the product for the needs related to business activities;
- If the warranty card is empty or missing seal (stamp) of the Seller;
- The absence of the holder's signature on the warranty card.

DAEWOO
DAEWOO
DAEWOO

_____ _____ _____ _____	Product _____ Model _____ Company _____ Date of sale _____	Product _____ Model _____ Company _____ Date of sale _____
----------------------------------	---	---



DAEWOO
POWER PRODUCTS



МАГАЗИН МАЙСТОРА
БАШ ПРОФЕСИОНАЛЬНЫЕ РЕШЕНИЯ

www.daewoopowerproducts.com

Manufactured under license of Daewoo International Corporation, Korea