

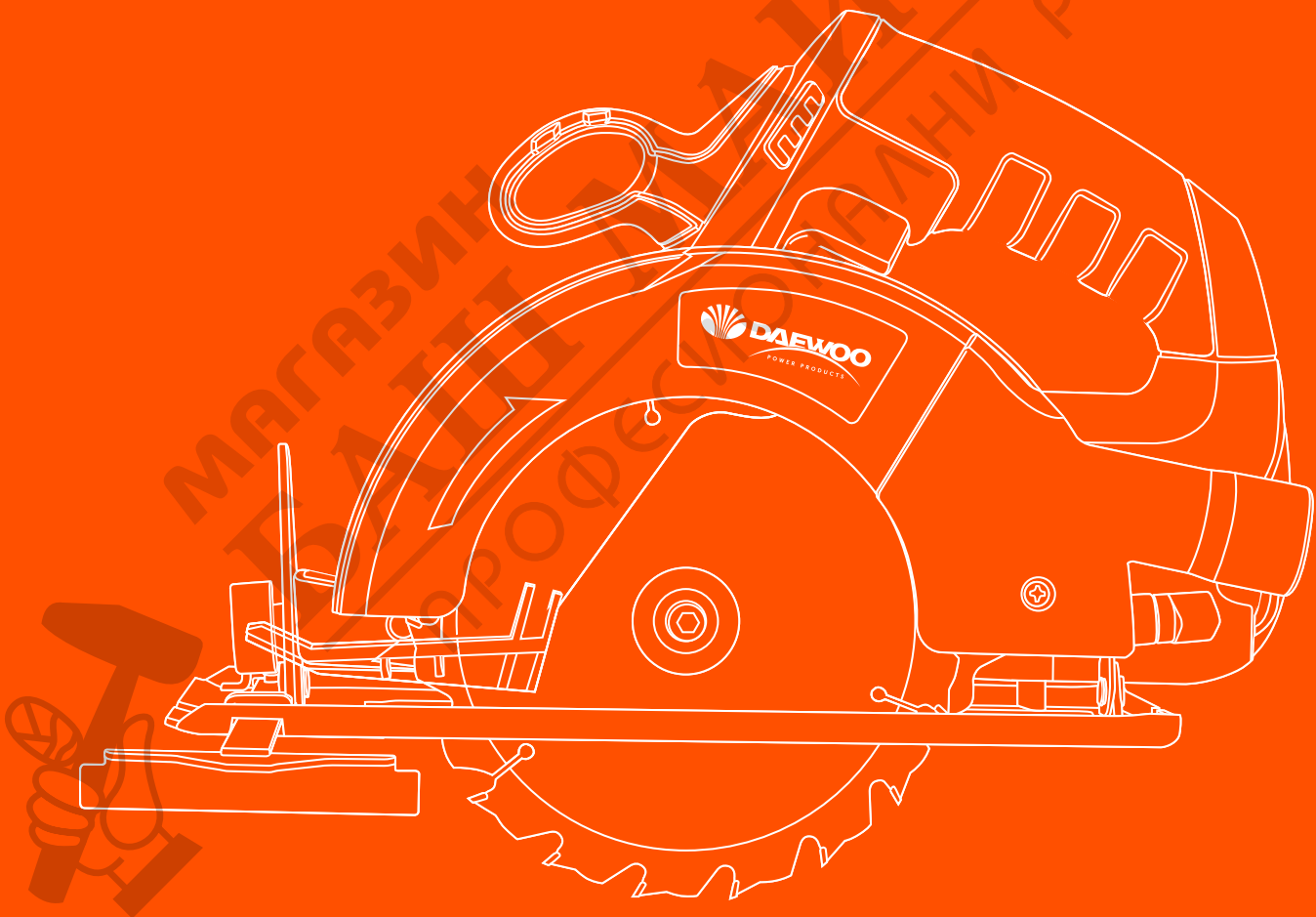

DAEWOO
POWER PRODUCTS

DALCS18-1

Lithium circular saw/ Sierra circular a batería de litio



USER'S MANUAL

www.daewoopowerproducts.com

Manufactured under license of Daewoo International Corporation, Korea

INDEX

1. APPLICATION	2
2. PARTS DESCRIPTION	2
3. PACKAGE CONTENT LIST	3
4. SYMBOLS	4
5. GENERAL POWER TOOL SAFETY WARNINGS	4
6. ASSEMBLY	8
7. OPERATION	9
8. CLEANING, MAINTENANCE AND STORAGE	9
9. DISPOSAL	10
10. TROUBLESHOOTING	10
11. TECHNICAL DATA	11
WARRANTY	12

ÍNDICE

1. APLICACIÓN	13
2. DESCRIPCIÓN DE PIEZAS	13
3. LISTA DEL CONTENIDO DEL PAQUETE	14
4. SÍMBOLOS	15
5. ADVERTENCIAS GENERALES DE SEGURIDAD	15
6. MONTAJE	19
7. OPERACIÓN	20
8. LIMPIEZA, MANTENIMIENTO Y ALMACENAMIENTO	21
9. DESHECHOS	21
10. SOLUCIÓN DE PROBLEMAS	22
11. DATOS TÉCNICOS	22
GARANTÍA	23



1. APPLICATION

This circular saw is designed for sawing timber workpieces. It is designed for domestic use and is not designed for commercial, trade or industrial use.



WARNING! Please read and understand this instruction manual before use and keep it for your future reference. Your power tool should only be passed on together with this instruction manual.



WARNING! To reduce risk of injury, only use battery pack. Other type of battery pack may burst causing personal injury and damage. The battery pack must be recharged only with the battery charger.

2. PARTS DESCRIPTION

FIG A

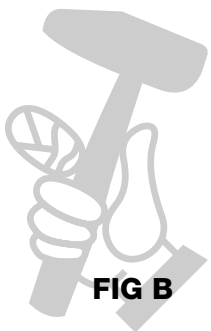
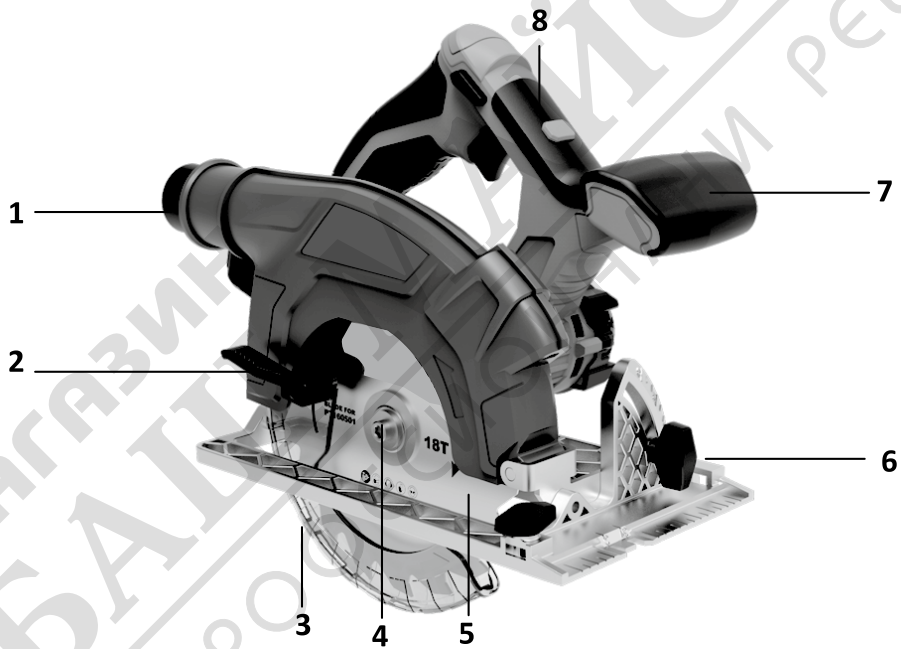

FIG B

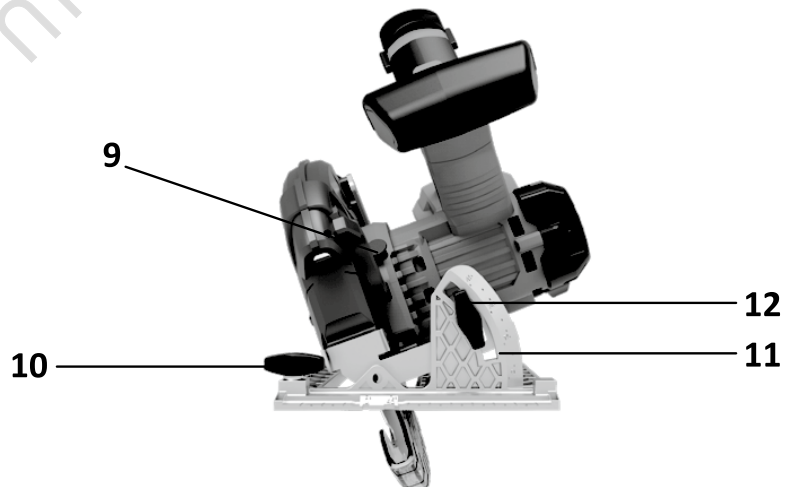
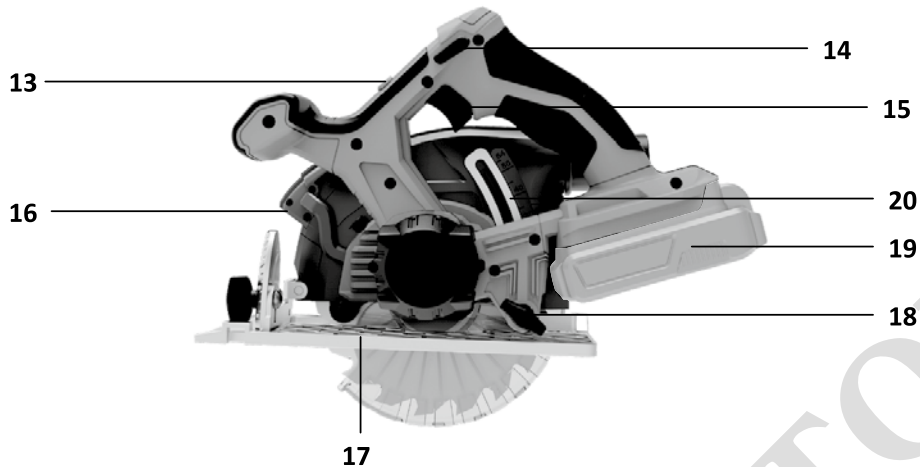

FIG C



- | | |
|-------------------------|-----------------------------------|
| 1. Dust extraction port | 11. Mitre angle scale |
| 2. Lower guard lever | 12. Mitre angle adjustment knob |
| 3. Lower guard | 13. Laser on/off switch |
| 4. Blade clamp bolt | 14. Lock off button |
| 5. Saw blade | 15. On/off trigger switch |
| 6. Guide bar | 16. Laser module |
| 7. Auxiliary handle | 17. Base plate |
| 8. Main handle | 18. Cutting depth adjustment knob |
| 9. Spindle lock button | 19. Battery pack (not included) |
| 10. Guide bar knob | 20. Cutting depth scale |

3. PACKAGE CONTENT LIST

- 1 x Circular Saw
- 1 x 165mm Saw Blade
- 1 x Guide Bar
- 1 x Allen Key
- 1 x Instruction Manual
- 1 x Warranty Certificate

- Remove all packing materials
- Ensure all parts on the contents list are present
- Check the appliance, and all accessories for transportation damages











WARNING! Packaging material are not toys! Children must not play with plastic bags! Danger of suffocation!



If any parts are missing or damaged, please contact your Service.

4. SYMBOLS

The following symbols are used in this manual and/or on the circular saw.

	Denotes risk of personal injury or damage to the tool		Australian Regulatory Compliance mark
	Read instruction manual before use		Dispose appliances according to the regulation and requirement of local council
	Wear hearing protection		Wear protective gloves
	Wear protective glasses		Wear breathing protection

5. GENERAL POWER TOOL SAFETY WARNINGS

WARNING! Read all safety warnings and all instructions. Failure to following the warnings and instructions may result in an electric shock, fire andlor serious injury.

Save all warnings and instructions for future reference!

The term "power tool" in the warnings refers to your mains-operated (corded) power tool ar battery-operated (cordless) power tool.

5.1 Work area safety

- a) Keep work area clean and well lit. Cluttered ar dark areas invite accidents.
- b) Do not operate power tools in explosive atmospheres, such as in the presence of flammable liquids, gases or dust. Power tools create sparks which may ignite the dust of fumes.
- e) Keep children and bystanders away while operating a power tool. Distractions can cause you to lose control.

5.2 Electrical safety

- a) Power tool plugs must match the outlet. Never modify the plug in any way. Do not use any adapter plugs with earthed (grounded) power tools. Unmodified plugs and matching outlets wil1 reduce the risk of an electric shock.
- b) Avoid body contact with earthed or grounded surfaces, such as pipes, radiators, ranges and refrigerators. There is an increased risk of electric shock if your body is earthed ar grounded.
- c) Do not expose power tools to rain or wet conditions. Water entering a power tool wil1 increase the risk of an electric shock.
- d) Do not abuse the cord. Never use the cord for carrying, pulling or unplugging the power tool. Keep cord away from heat, oil, sharp edges or moving parts. Damaged ar entangled cords increase

the risk of electric shock.

e) When operating a power tool outdoors, use an extension cord suitable for outdoor use. Use of a cord suitable for outdoor use reduces the risk of electric shock.

If operating a power tool in a damp location is unavoidable, use a residual current device (RCD) protected supply. Use of an RCD reduces the risk of electric shock.

5.3 Personal safety

a) Stay alert, watch what you are doing and use common sense when operating a power tool. Do not use a power tool while you are tired or under influence of drugs, alcohol or medication. A moment of inattention while operating power tools may result in serious personal injury.

b) Use personal protective equipment. Always wear eye protection. Protective equipment such as dust mask, non-skid safety shoes, hard hat, or hearing protection used for appropriate conditions will reduce personal injuries.

c) Prevent unintentional starting. Ensure the switch is in the off-position before connecting to power source and/or battery pack, picking up or carrying the tool. Carrying power tools with your finger on the switch or energising power tools that have the switch on invites accidents.

d) Remove any adjusting key or wrench before turning the power tool on. A wrench or a key left attached to a rotating part of the power tool may result in personal injury.

e) Do not overreach. Keep proper footing and balance at all times. This enables better control of the power tool in unexpected situations.

f) Dress properly. Do not wear loose clothing or jewellery. Keep your hair, clothing and gloves away from moving parts. Loose clothes, jewellery or long hair can be caught in moving parts.

g) If devices are provided for the connection of dust extraction and collection facilities, ensure these are connected and properly used. Use of dust collection can reduce dust-related hazards.

5.4 Power tool use and care

a) Do not force the power tool. Use the correct power tool for your application. The correct power tool will do the job better and safer at the rate for which it was designed.

b) Do not use the power tool if the switch does not turn it on and off. Any power tool that cannot be controlled with the switch is dangerous and must be repaired.

c) Disconnect the plug from the power source and or the battery pack from the power tool before making any adjustments, changing accessories, or storing power tools. Such preventive safety measures reduce the risk of starting the power tool accidentally.

d) Store the power tools out of reach of children and do not allow persons unfamiliar with the power tool or these instructions to operate the power. Power tools are dangerous in the hands of untrained users.

e) Maintain power tools. Check for misalignment or binding of moving parts, breakage of parts and any other condition that may affect the power tools operation. If damaged, have the power tool repaired before use. Many accidents are caused by poorly maintained power tools.

f) Keep cutting tools sharp and clean. Properly maintained cutting tools with sharp cutting edges are less likely to bind and are easier to control.

g) Use the power tool, accessories and tool bits etc. in accordance with these instructions, taking into account the working conditions and the works to be performed. Use the power tool for operations different from those intended could result in hazardous situations.

5.5 Battery tool use and care

a) Recharge only with the charger specified by the manufacturer. A charger that is suitable for one type of battery pack may create a risk of fire when used with another battery pack.

b) Use power tools only with specifically designated battery packs. Use of any other battery packs

may create a risk of injury and fire.

- c) When battery pack is not in use, keep it away from other metal objects, like paper clips, coins, keys, nails, screws or other small metal objects, that can make a connection from one terminal to another. Shorting the battery terminals together may cause burns or a fire.
- d) Under abusive conditions, liquid may be ejected from the battery; avoid contact. If contact accidentally occurs, flush with water. If liquid contacts eyes, additionally seek medical help. Liquid ejected from the battery may cause irritation or burns.

5.6 Service

- a) Have your power tool serviced by a qualified repair person using only identical replacement parts. This will ensure that the safety of the power tool is maintained.

5.7 Safety instructions for all saws

- a) **DANGER:** Keep hands away from cutting area and the blade. Keep your second hand on auxiliary handle, or motor housing. If both hands are holding the saw, they cannot be cut by the blade.
- b) Do not reach underneath the workpiece. The guard cannot protect you from the blade below the workpiece.
Adjust the cutting depth to the thickness of the workpiece. Less than a full tooth of the blade teeth should be visible below the workpiece.
- d) Never hold piece being cut in your hands or across your leg. Secure the workpiece to a stable platform. It is important to support the work properly to minimize body exposure, blade binding, or loss of control.
- e) Hold power tool by insulated gripping surfaces when performing an operation where the cutting tool may contact hidden wiring or its own cord. Contact with a "live" wire will also make exposed metal parts of the power tool "live" and shock the operator.
- f) When ripping always use a rip fence or straight edge guide. This improves the accuracy of cut and reduces the chance of blade binding.
- g) Always use blades with correct size and shape (diamond versus round) of arbour holes. Blades that do not match the mounting hardware of the saw will run eccentrically, causing loss of control.
- h) Never use damaged or incorrect blade washers or bolt. The blade washers and bolt were specially designed for your saw, for optimum performance and safety of operation.

5.8 Causes and operator prevention of kickback

- Kickback is a sudden reaction to a pinched, bound or misaligned saw blade, causing an uncontrolled saw to lift up and out of the workpiece toward the operator;
- When the blade is pinched or bound tightly by the kerf closing down, the blade stalls and the motor reaction drives the unit rapidly back toward the operator;
- If the blade becomes twisted or misaligned in the cut, the teeth at the back edge of the blade can dig into the top surface of the wood causing the blade to climb out of the kerf and jump back toward the operator.

Kickback is the result of saw misuse and or incorrect operating procedures or conditions and can be avoided by taking proper precautions as given below.

- a) Maintain a firm grip with both hands on the saw and position your arms to resist kickback forces. Position your body to either side of the blade, but not in line with the blade. Kickback could cause the saw to jump backwards, but kickback forces can be controlled by the operator, if proper precautions are taken.
- b) When blade is binding, or when interrupting a cut for any reason, release the trigger and hold the saw motionless in the material until the blade comes to a complete stop. Never attempt to remove the saw from the work or pull the saw backward while the blade is in motion or kickback

may occur. Investigate and take corrective actions to eliminate the cause of blade binding.

c) When restarting a saw in the workpiece, centre the saw blade in the kerf and check that saw teeth are not engaged into the material. If saw blade is binding, it may walk up or kickback from the workpiece as the saw is restarted.

d) Support large panels to minimise the risk of blade pinching and kickback. Large panels tend to sag under their own weight. Supports must be placed under the panel on both sides, near the fine of cut and near the edge of the panel.

e) Do not use dull or damaged blades. Unsharpened or improperly set blades produce narrow kerf causing excessive friction, blade binding and kickback.

f) Blade depth and bevel adjusting locking levers must be tight and secure before making cut. If blade adjustment shifts while cutting, it may cause binding and kickback.

g) Use extra caution when making a "plunge cut" into existing walls or other blind areas. The protruding blade may cut objects that can cause kickback.

5.9 Safety instructions for lower guard saw

a) Check lower guard for proper closing before each use. Do not operate the saw if lower guard does not move freely and close instantly. Never clamp or tie the lower guard into the open position. If saw is accidentally dropped the lower guard may be bent. Raise the lower guard with the retracting handle and make sure it moves freely and does not touch the blade or any other part, in all angles and depths of cut.

b) Check the operation of the lower guard spring. If the guard and the spring are not operating properly, they must be serviced before use. Lower guard may operate sluggishly due to damaged parts, gummy deposits, or a build-up of debris.

Lower guard may be retracted manually only for special cuts such as "plunge cuts" and "compound cuts." Raise lower guard by retracting handle and as soon as blade enters the material, the lower guard must be released. For all other sawing, the lower guard should operate automatically.

d) Always observe that the lower guard is covering the blade before placing saw down on bench or floor. An unprotected, coasting blade will cause the saw to walk backwards, cutting whatever is in its path. Be aware of the time it takes for the blade to stop after switch is released.

5.10 Residual risks

Although the safety instructions contain extensive instructions on safe working with this circular saw and despite proper use, additional residual risks may arise when using this mitre saw.

These include:

a) Injuries caused by touching any rotating moving parts.

b) Injuries caused when changing any parts and accessories.

c) Injuries caused by projected parts or tool adapter that break during use.

d) Damage to eyes and hearing if effective protection are not worn.



6. ASSEMBLY



WARNING! Remove the battery pack before assembly. Do not use grinding discs. Wear protective gloves, the cutting edges of the saw blade teeth are sharp. The cutting edges present a risk of injury. Never adjust cutting depth and angle while the blade is turning.

6.1 Attaching the saw blade (Fig. D)

- Press and hold the spindle lock button (9) and use allen key to remove blade bolt and outer blade flange.
- Retract the lower blade guard (3) by raising the blade guard lever.
- Slip the blade in position. Ensure arrow on the blade points in the same direction as the arrow on the upper blade guard.
- Insert the outer flange and blade clamp bolt.
- Press down the spindle lock button (9) and tighten the blade clamp bolt with allen key.

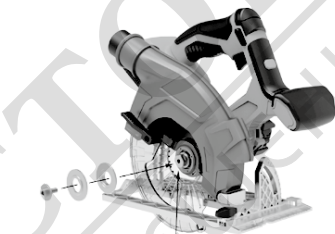

FIG D

6.2 Removing the saw blade (Fig. E)

- Use the allen key to loosen the blade clamp bolt while pressing down the spindle lock button.
- Remove the blade clamp bolt and outer flange.
- Raise the lower guard (3) and remove the saw blade.

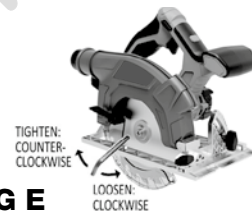

FIG E

6.3 Adjusting the cutting depth (Fig. F)

- Loosen the cutting depth adjustment knob (18) by turning it anti-clockwise. The max. cutting depth is 54mm (90°) and 40mm (45°).
- Hold the base plate against the edge of the workpiece and lift the saw to the desired cutting depth.
- Tighten the cutting depth adjustment knob.

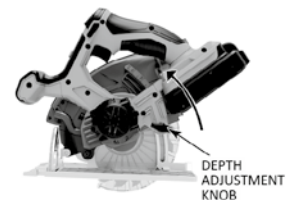

FIG F

6.4 Setting the mitre angle (Fig.G)

- Loosen the mitre angle adjustment knob (12) by turning it anti-clockwise.
- Adjust the mitre angle of your cut.
- Tighten the mitre angle adjustment knob.



FIG G

6.5 Mounting the guide bar (Fig.G)

- Loosen the guide bar knob (10) by turning it anti-clockwise.
- Slide the guide bar through the slots in the base plate to the desired width.
- Tighten the guide bar knob.

7. OPERATION

7.1 Insert and remove the battery pack (sold separately)



WARNING! Before inserting or removing the circular saw's battery, make sure the appliance is switched off.

- To insert the battery pack, align the battery pack with the circular saw base and slide the battery pack into the circular saw, so that the battery pack is locked in position.
- To remove the battery pack, press the battery's release button and pull the battery pack off at the same time.

7.2 General cutting

- Check and make sure the workpiece is held securely.
- Press the lock off button and the variable speed on/off trigger switch at the same time to turn on the circular saw.
- Put the base plate against the workpiece.
- Hold the circular saw with both hands.
- When the saw blade reaches full speed, cut the workpiece slowly.
- Release the variable speed on/off trigger switch to turn off the circular saw. The saw blade will continue rotating for a few seconds after the circular saw has been switched off.

7.3 Laser beam



WARNING! Before inserting or removing the circular saw's battery, make sure the appliance is switched off.

- Mark the cutting line on the workpiece.
- Adjust the cutting angle and cutting depth as needed.
- Put the circular saw on the workpiece.
- Press the laser on/off switch (13) to turn on the laser module.
- Align the laser beam with the mark on the workpiece.
- Turn on the circular saw and cut the workpiece slowly. Keep the laser beam on the cutting line.
- Turn off the laser beam after cutting.

7.4 Dust extraction

A vacuum cleaner can be connected to the dust extraction port (1) either directly or using an adapter to collect the saw dust.

8. CLEANING, MAINTENANCE AND STORAGE



WARNING! Remove the battery before any cleaning, maintenance or storage.

8.1 Cleaning

- Keep the ventilation slots free from dust and dirt to prevent overheating.
- Regularly clean the circular saw's housing with a soft cloth, preferably after each use. If the dirt

does not come off, use a soft cloth moistened with soapy water.

c) Never use solvents such as petrol, alcohol, ammonia water etc. These solvents may damage the plastic parts.

8.2 Maintenance

a) The circular saw has been designed to operate over a long period of time with a minimum of maintenance. Continuous satisfactory operation depends upon proper care and regular cleaning.

b) The circular saw shall only be repaired by an authorised service centre.

8.3 Storage

a) Thoroughly clean the circular saw and its accessories before storage.

b) Store the circular saw out of the reach of children in a stable and secure place.

9. DISPOSAL



Dispose appliances according to the regulations and requirements of your local council. If appliances are disposed in landfills or dumps, hazardous substances may leak into the ground water and get into the food chain, damaging your health and well-being.

10. TROUBLESHOOTING

Problem	Possible causes	Possible solutions
Cannot start	Battery pack not installed properly	Remove and insert the battery pack again
	Battery not charged	Charge the battery
	Internal damage or wear e.g. motor is damaged	Repair by an authorised service centre
Can only run slowly	Battery is not charged	Charge the battery
	Battery wears out	Replace the battery with a new one
Cannot cut efficiently	Saw blade is blunt	Change the saw blade
Noisy or rattling	Internal damage or wear	Repair by an authorised service centre
Overheat	Ventilation vents blocked	Clean the dust from the ventilation vents
	Saw blade is blunt	Change the saw blade
	The circular saw is running for too long	Turn off the circular saw and let it cool down

11. TECHNICAL DATA

Power: 18 V

No load speed: 4000 rpm

Blade diameter: 150 mm X 18 T

Cutting capacity: 48 mm (90°) / 36 mm (45°)

Functions: laser, electric brake, spindle lock.

Includes: LED light and punch base plate

Sound level LpA: 75.3 dB

Sound level LwA: 86.3 dB

Vibration: ah,W= 3,015 m²/s

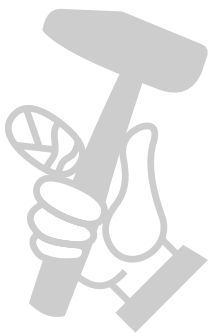

МАГАЗИН МАЙСТОРА®
БАШ ПРОФЕСІОНАЛНИ РЕШЕНІЯ

1. APLICACIÓN

Esta sierra circular está diseñada para aserrar piezas de trabajo de madera. Está diseñado para uso doméstico y no está diseñado para uso comercial o industrial.



ADVERTENCIA! Lea y comprenda este manual de instrucciones antes de su uso y guárdelo para futuras consultas. Su herramienta eléctrica solo debe pasarse junto con este manual de instrucciones.



ADVERTENCIA! Para reducir el riesgo de lesiones, solo use el paquete de baterías Xfinity Plus. Otro tipo de paquete de baterías puede explotar, causando lesiones personales y daños. La batería se debe recargar solo con el cargador de batería Xfinity Plus.

2. DESCRIPCION DE PIEZAS

FIG A

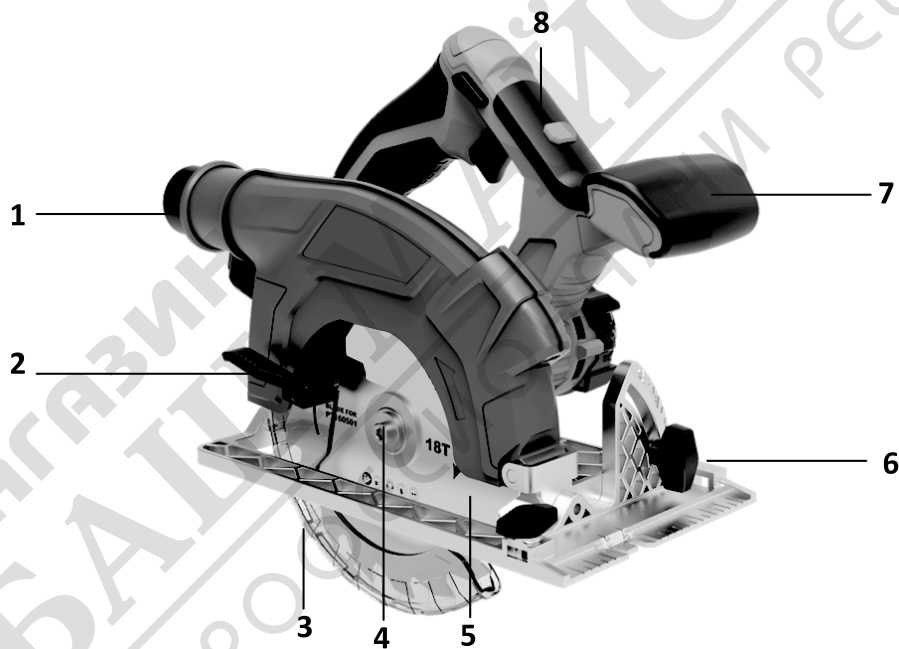

FIG B

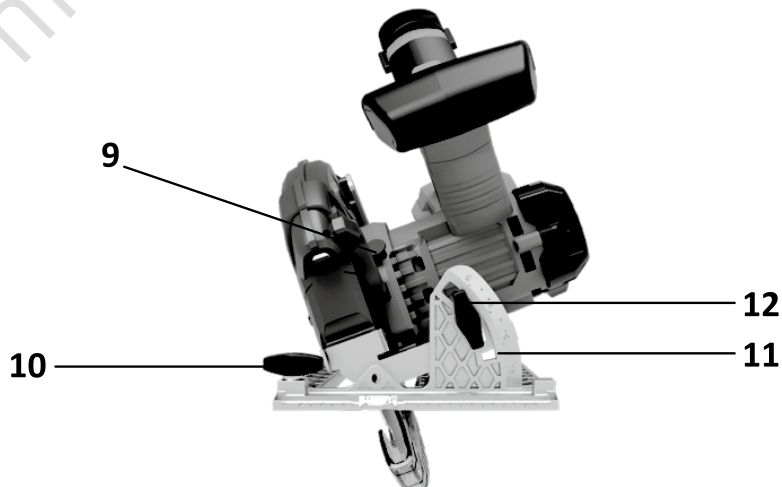
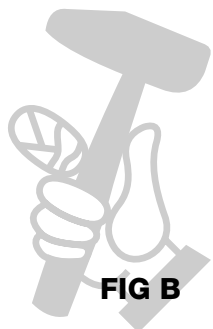
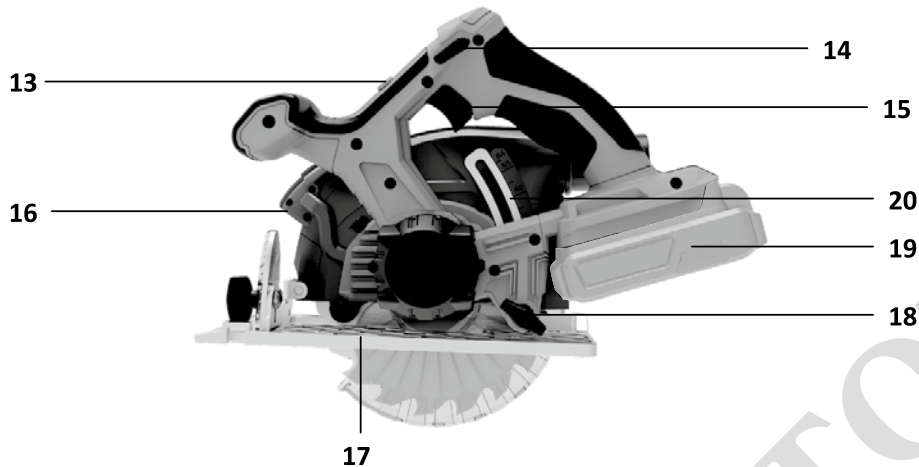

FIG C



- | | |
|-------------------------------------|---|
| 1. Puerto de extracción de polvo | 11. Escala de ángulo de inglete |
| 2. Palanca de guardia inferior | 12. Perilla de ajuste del ángulo de inglete |
| 3. Guardia inferior | 13. Interruptor láser encendido/apagado |
| 4. Perno de sujeción de la cuchilla | 14. Botón de bloqueo |
| 5. Hoja de sierra | 15. Disparador de encendido / apagado |
| 6. Barra de guía | 16. Módulo láser |
| 7. Mango auxiliar | 17. Plato base |
| 8. Manija principal | 18. Perilla de ajuste de profundidad de corte |
| 9. Botón de bloqueo del eje | 19. Batería (no incluida) |
| 10. Perilla de la barra guía | 20. Escala de profundidad de corte |

3. LISTA DEL CONTENIDO DEL PAQUETE

- 1 x Sierra circular
- 1 x Hoja de sierra 165mm
- 1 x Barra guía
- 1 x Llave Allen
- 1 x Manual de instrucciones
- 1 x Certificado de garantía

- Retire todos los materiales del paquete
- Asegúrese que todas las partes que contiene la lista estén presentes
- Verifique el electrodoméstico y todos los accesorios por daños de transportación



ADVERTENCIA! Los materiales de empaque no son juguetes! ¡Los niños no deben jugar con bolsas de plástico! Peligro de asfixia!



Si alguna parte falta o está dañada, póngase en contacto con su servicio.