

D	Originalbetriebsanleitung Mauernutfräse	FIN	Alkuperäiskäyttöohje Rakojyrsimen
GB	Original operating instructions Masonry channel cutter	SLO	Originalna navodila za uporabo Zidarski rezkalnik za zidne utore
F	Instructions d'origine Fraise à rainure de mur	H	Eredeti használati utasítás Falhoronymaró
I	Istruzioni per l'uso originali Scanalatrice per muro	RO	Instrucțiuni de utilizare originale Mașină de frezat nuturi în zidărie
DK/ N	Original betjeningsvejledning Murnotfræser	P	Manual de instrucções original Fresadora de roços
S	Original-bruksanvisning Murspårfräs	HR/ BIH	Originalne upute za uporabu Glodalicu za izradu utora
CZ	Originální návod k obsluze Drážkovací frézku na zdivo	RS	Originalna uputstva za upotrebu Glodalica za izradu utora u zidu
SK	Originálny návod na obsluhu Drážkovacia fréza na murivo	TR	Orijinal Kullanma Talimatı Kanal Açma Frezesi
NL	Originele handleiding Muursleuffrees	EE	Originaalkasutusjuhend Soonefrees
E	Manual de instrucciones original Fresadora ranuradora		

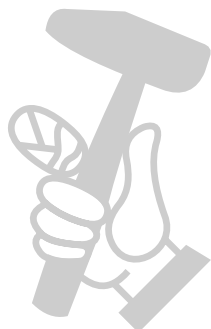

13



Art.-Nr.: 43.507.40



I.-Nr.: 21010

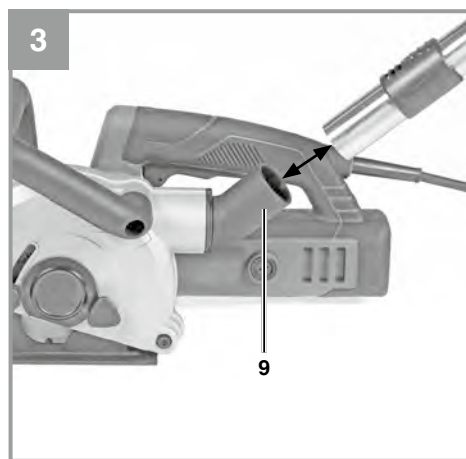
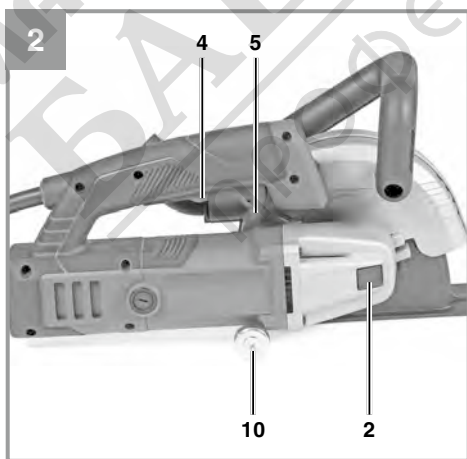
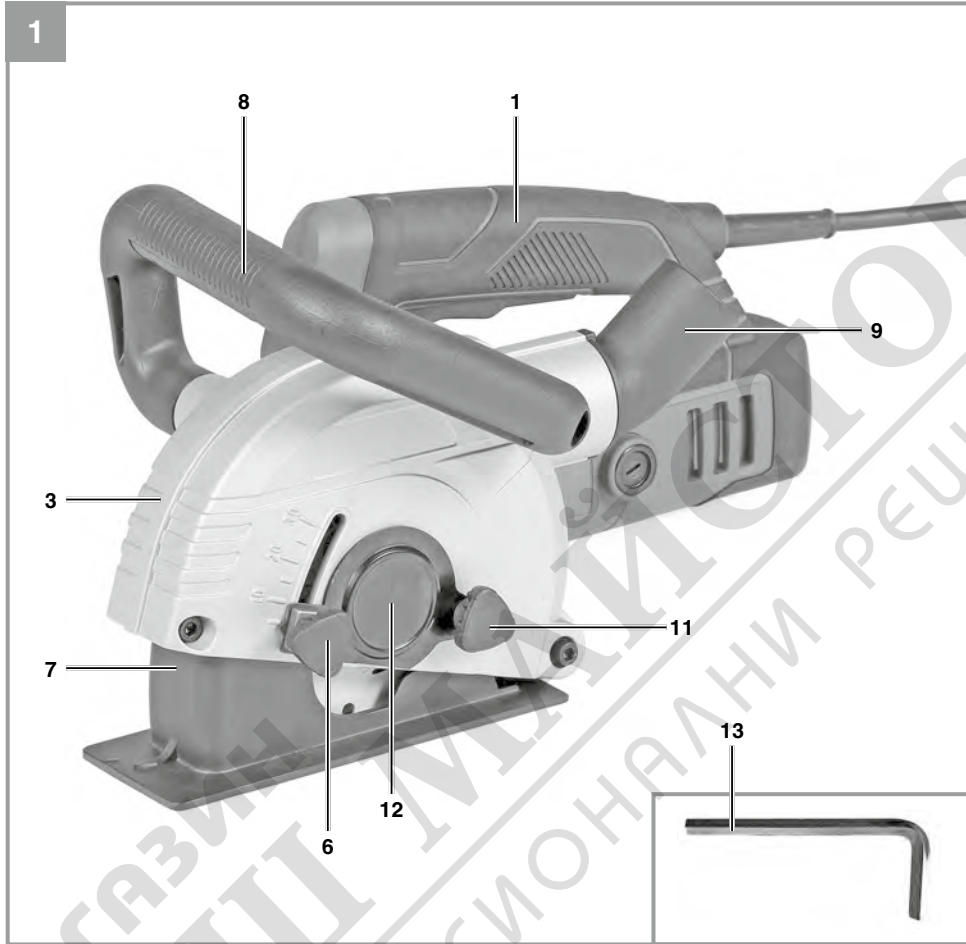

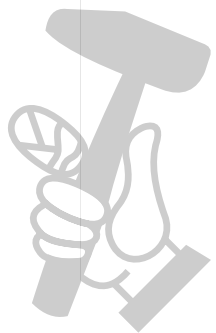
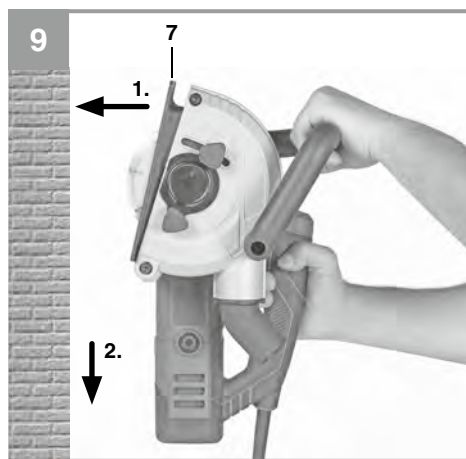
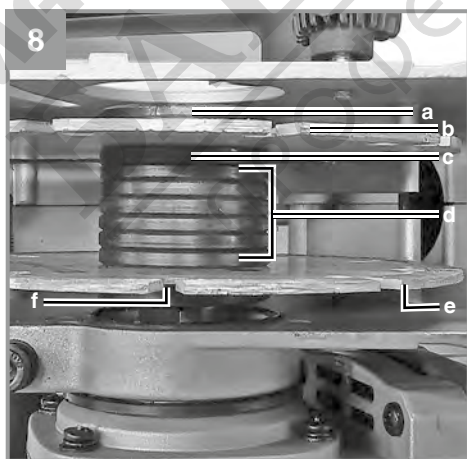
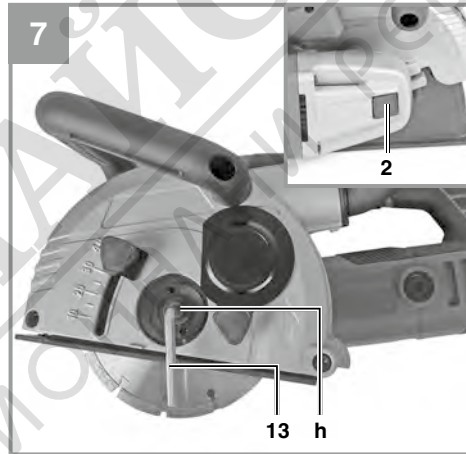
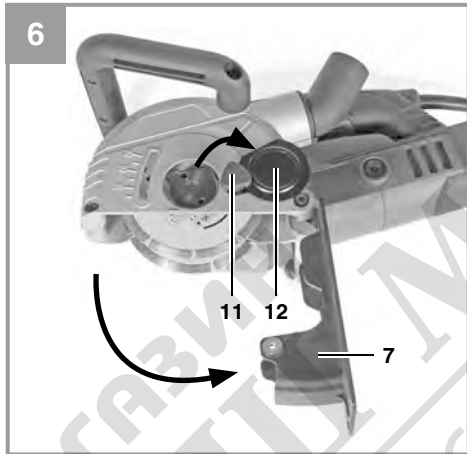
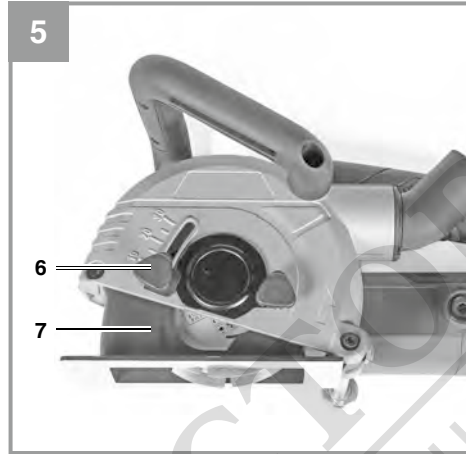
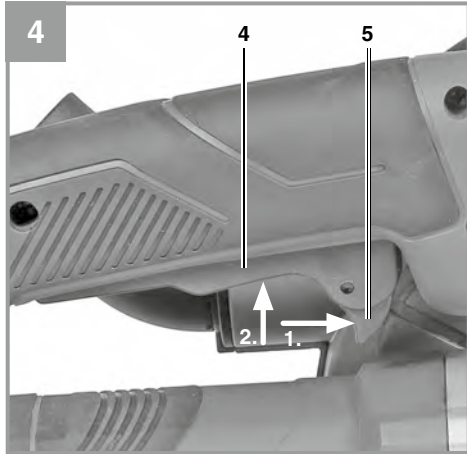

МАГАРЫНДЫН АЖААХ ЭРХЭМЧИЙН ХААГАГАМШИГ
 МАГАРЫНДЫН АЖААХ ЭРХЭМЧИЙН ХААГАГАМШИГ
 МАГАРЫНДЫН АЖААХ ЭРХЭМЧИЙН ХААГАГАМШИГ

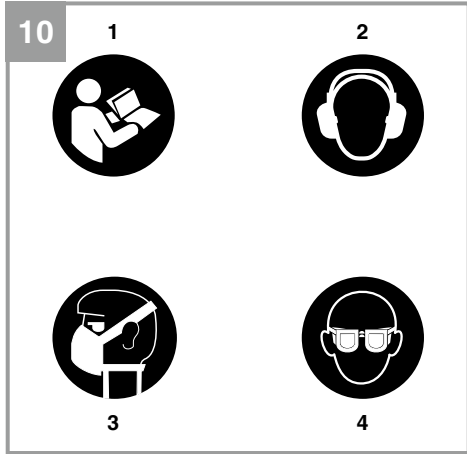

МАГАЗИН
БАШ МАЙСТОРА[®]
ПРОФЕСІОНАЛНИ РЕШЕННЯ

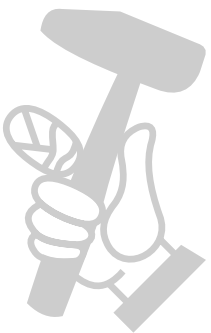

Danger!

When using the equipment, a few safety precautions must be observed to avoid injuries and damage. Please read the complete operating instructions and safety regulations with due care. Keep this manual in a safe place, so that the information is available at all times. If you give the equipment to any other person, hand over these operating instructions and safety regulations as well. We cannot accept any liability for damage or accidents which arise due to a failure to follow these instructions and the safety instructions.

Explanation of the symbols used (see Fig. 10)

1. **Danger!** - Read the operating instructions to reduce the risk of injury.
2. **Caution! Wear ear-muffs.** The impact of noise can cause damage to hearing.
3. **Caution! Wear a breathing mask.** Dust which is injurious to health can be generated when working on wood and other materials. Never use the device to work on any materials containing asbestos!
4. **Caution! Wear safety goggles.** Sparks generated during working or splinters, chips and dust emitted by the device can cause loss of sight.

1. Safety regulations

The corresponding safety information can be found in the enclosed booklet.

Danger!**Read all safety regulations and instructions.**

Any errors made in following the safety regulations and instructions may result in an electric shock, fire and/or serious injury.

Keep all safety regulations and instructions in a safe place for future use.**2. Layout and items supplied****2.1 Layout (Fig. 1/2)**

1. Handle
2. Spindle lock
3. Guard hood
4. Operating switch
5. Safety lock-off
6. Locking screw for depth stop
7. Depth stop
8. Additional handle
9. Connection for dust extractor

10. Guide roller
11. Screw for flange cover
12. Flange cover
13. Hex key

2.2 Items supplied

Please check that the article is complete as specified in the scope of delivery. If parts are missing, please contact our service center or the sales outlet where you made your purchase at the latest within 5 working days after purchasing the product and upon presentation of a valid bill of purchase. Also, refer to the warranty table in the service information at the end of the operating instructions.

- Open the packaging and take out the equipment with care.
- Remove the packaging material and any packaging and/or transportation braces (if available).
- Check to see if all items are supplied.
- Inspect the equipment and accessories for transport damage.
- If possible, please keep the packaging until the end of the guarantee period.

Danger!

The equipment and packaging material are not toys. Do not let children play with plastic bags, foils or small parts. There is a danger of swallowing or suffocating!

- Cutting wheel (2x)
- Flange nut wrench
- Original operating instructions
- Safety instructions

3. Proper use

This equipment is designed for cutting channels for pipes and cables in masonry walls.

This equipment is not suitable for making cuts in reinforced concrete.

The equipment is to be used only for its prescribed purpose. Any other use is deemed to be a case of misuse. The user / operator and not the manufacturer will be liable for any damage or injuries of any kind caused as a result of this.

Please note that our equipment has not been designed for use in commercial, trade or industrial applications. Our warranty will be voided if the

machine is used in commercial, trade or industrial businesses or for equivalent purposes.

4. Technical data

Mains voltage: 220-240 V ~ 50 Hz
 Power input: 1700 W
 Rated speed: 7000 min⁻¹
 Max. wheel diameter (rated capacity): 150 mm
 Mounting hole: 22.2 mm
 Channel depth: 8 - 40 mm
 Channel width: 8 - 38 mm
 Mounting spindle thread: M8
 Protection class: II / 
 Weight: 5.87 kg

Danger!

Sound and vibration

Sound and vibration values were measured in accordance with EN 60745.

L_{pA} sound pressure level 97,5 dB(A)
 K_{pA} uncertainty 3 dB
 L_{WA} sound power level 108,5 dB(A)
 K_{WA} uncertainty 3 dB

Wear ear-muffs.

The impact of noise can cause damage to hearing.

Total vibration values (vector sum of three directions) determined in accordance with EN 60745.

Vibration emission value $a_n = 7.824 \text{ m/s}^2$
 K uncertainty = 1.5 m/s²

The specified vibration value was established in accordance with a standardized testing method. It may change according to how the electric equipment is used and may exceed the specified value in exceptional circumstances.

The specified vibration value can be used to compare the equipment with other electric power tools.

The specified vibration value can be used for initial assessment of a harmful effect.

Keep the noise emissions and vibrations to a minimum.

- Only use appliances which are in perfect working order.
- Service and clean the appliance regularly.
- Adapt your working style to suit the appliance.
- Do not overload the appliance.
- Have the appliance serviced whenever necessary.
- Switch the appliance off when it is not in use.
- Wear protective gloves.

Caution!

Residual risks

Even if you use this electric power tool in accordance with instructions, certain residual risks cannot be ruled out. The following hazards may arise in connection with the equipment's construction and layout:

1. Lung damage if no suitable protective dust mask is used.
2. Damage to hearing if no suitable ear protection is used.
3. Health damage caused by hand-arm vibrations if the equipment is used over a prolonged period or is not properly guided and maintained.

5. Before starting the equipment

Before you connect the equipment to the mains supply make sure that the data on the rating plate are identical to the mains data.

Warning!

Always pull the power plug before making adjustments to the equipment.

5.1 Setting the groove depth (Fig. 1)

- Slacken the locking screw (6).
- Set the depth stop (7) to the desired depth.
- Tighten the locking screw (6).

5.2 Fitting the dust extractor adapter (Fig. 3)

Caution! For health and safety reasons it is imperative that you use a dust extractor. The extractor socket is suitable for use on vacuum extractor units (vacuum cleaners). The extractor unit must be suitable for the extraction of fine dust.

Connect a suitable vacuum cleaner, as shown in Fig. 3, to the dust extraction connector.

5.3 Trial run for new diamond cutting wheels

Have the equipment run in idle mode for at least 1 minute with the cutting wheels fitted. Replace vibrating wheels immediately.

6. Operation

6.1 Switch (Fig. 4)

The equipment comes with a safety switch which is designed to prevent accidents.

To start the equipment, push the locking lever (5) forwards and then press the On/Off switch (4).

Warning! Wait until the machine has reached its top speed.

6.2 Changing and setting the diamond cutting wheels (Fig. 5-8)

Danger! Pull the mains power plug out of the socket-outlet

Removing:

- Undo the locking screw for the depth stop (6) and remove (Fig. 5)
- Swing the depth stop (7) downwards (Fig. 6)
- Slacken the screw for the flange cover (11) and open the flange cover (12) (Fig. 6)
- Press and hold the spindle lock (2) and undo the socket head screw (h) with the supplied hex key (13) (Fig. 7)
- Remove the following as shown in Fig. 8:
 - the outer flange (a)
 - the top cutting wheel (b)
 - the top inner flange (c)
 - 6x spacers (d)
 - the bottom cutting wheel (e)
 - the bottom inner flange (f)

Important! Thoroughly clean all the spacers and flanges.

Fitting:

Important! Diamond cutting wheels must always be replaced as pairs!

- Fit the bottom inner flange (f) and the bottom cutting wheel (e)
 - Important!** Check the direction of rotation of the cutting wheel!
- Fit the number of spacers (d) required for the groove width
- Place the top inner flange (c) – with its raised side up – onto the last fitted spacer.
 - Important!** Each spacer is approx. 3.5 mm

wide. The groove width results from the number of spacers (d), the top inner flange (c) between the cutting wheels, and the thickness of the two cutting wheels

- Put on the top cutting wheel (b)
 - Important!** Check the direction of rotation of the cutting wheel!
- Fit any spacers (d) that might still be left over, reattach the outer flange (a), and screw the socket head screw (h) back in place.

Warning! All 6 spacers (d) must be fitted irrespective of the desired groove width!

Close and fasten the flange cover (12) and swivel the depth stop (7) back in place. Fasten the depth stop (7) using the locking screw for depth screw (6).

Important! Check that all the parts are seated firmly and correctly.

Caution:

Only ever press the spindle lock when the motor and grinding spindle are at a standstill! The spindle lock must be kept pressed while the wheel is being changed!

6.3 Motor

It is vital for the motor to be well ventilated during operation. Be sure, therefore, to keep the ventilation holes clean at all times.

6.4 Working with the masonry channel cutter (Fig. 9)

The device is fitted with an overload cut-out. The motor will cut out if overloaded. Relieve the load on the motor immediately and allow the masonry channel cutter to cool down for approx. 1 minute without load.

Danger! The device is suitable for dry cutting only!

- Use a cable/pipe detector to check for concealed electric cables and gas and water pipes in the wall before you start using the masonry channel cutter.
- Select the desired groove width (see 6.2) and groove depth (see 5.1).

Only ever guide the device along the workpiece while switched on.

- Place the device against the wall with the roller (10) against the wall.
- Switch on the device and then cut slowly into

the wall until the stop (7) rests against the wall.

- Now you can cut the groove in the wall. Take care with the cutting direction (a) as you do so. The device must always be handled on a counterrotating basis otherwise there is a risk that it may be forced out of the cut in an uncontrolled manner.
Caution! Cut in a straight line only. It is not possible to cut curves.
- At the end of the groove, swing the device out of the groove before you switch it off.
- You can then cut out the ridge between the two grooves with a chisel.

Important! It is prohibited to use this equipment on materials containing asbestos!

7. Replacing the power cable

Danger!

If the power cable for this equipment is damaged, it must be replaced by the manufacturer or its after-sales service or similarly trained personnel to avoid danger.

8. Cleaning, maintenance and ordering of spare parts

Danger!

Always pull out the mains power plug before starting any cleaning work.

8.1 Cleaning

- Keep all safety devices, air vents and the motor housing free of dirt and dust as far as possible. Wipe the equipment with a clean cloth or blow it with compressed air at low pressure.
- We recommend that you clean the device immediately each time you have finished using it.
- Clean the equipment regularly with a moist cloth and some soft soap. Do not use cleaning agents or solvents; these could attack the plastic parts of the equipment. Ensure that no water can seep into the device. The ingress of water into an electric tool increases the risk of an electric shock.

8.2 Carbon brushes

In case of excessive sparking, have the carbon brushes checked only by a qualified electrician.

Danger! The carbon brushes should not be replaced by anyone but a qualified electrician.

8.3 Maintenance

There are no parts inside the equipment which require additional maintenance.

8.4 Ordering replacement parts:

Please quote the following data when ordering replacement parts:

- Type of machine
- Article number of the machine
- Identification number of the machine
- Replacement part number of the part required

For our latest prices and information please go to www.Einhell-Service.com

9. Disposal and recycling

The equipment is supplied in packaging to prevent it from being damaged in transit. The raw materials in this packaging can be reused or recycled. The equipment and its accessories are made of various types of material, such as metal and plastic. Never place defective equipment in your household refuse. The equipment should be taken to a suitable collection center for proper disposal. If you do not know the whereabouts of such a collection point, you should ask in your local council offices.

10. Storage

Store the equipment and accessories in a dark and dry place at above freezing temperature. The ideal storage temperature is between 5 and 30 °C. Store the electric tool in its original packaging.

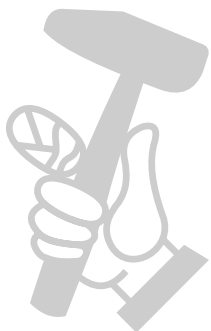



For EU countries only

Never place any electric power tools in your household refuse.

To comply with European Directive 2012/19/EC concerning old electric and electronic equipment and its implementation in national laws, old electric power tools have to be separated from other waste and disposed of in an environment-friendly fashion, e.g. by taking to a recycling depot.

Recycling alternative to the return request:

As an alternative to returning the equipment to the manufacturer, the owner of the electrical equipment must make sure that the equipment is properly disposed of if he no longer wants to keep the equipment. The old equipment can be returned to a suitable collection point that will dispose of the equipment in accordance with the national recycling and waste disposal regulations. This does not apply to any accessories or aids without electrical components supplied with the old equipment.

The reprinting or reproduction by any other means, in whole or in part, of documentation and papers accompanying products is permitted only with the express consent of the Einhell Germany AG.

Subject to technical changes

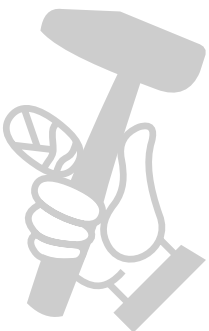

Service information

We have competent service partners in all countries named on the guarantee certificate whose contact details can also be found on the guarantee certificate. These partners will help you with all service requests such as repairs, spare and wearing part orders or the purchase of consumables.

Please note that the following parts of this product are subject to normal or natural wear and that the following parts are therefore also required for use as consumables.

Category	Example
Wear parts*	Carbon brushes
Consumables*	Cutting wheels
Missing parts	

* Not necessarily included in the scope of delivery!

In the effect of defects or faults, please register the problem on the internet at www.Einhell-Service.com. Please ensure that you provide a precise description of the problem and answer the following questions in all cases:

- Did the equipment work at all or was it defective from the beginning?
- Did you notice anything (symptom or defect) prior to the failure?
- What malfunction does the equipment have in your opinion (main symptom)? Describe this malfunction.



Warranty certificate

Dear Customer,

All of our products undergo strict quality checks to ensure that they reach you in perfect condition. In the unlikely event that your device develops a fault, please contact our service department at the address shown on this guarantee card. You can also contact us by telephone using the service number shown.

Please note the following terms under which guarantee claims can be made:

1. These guarantee terms apply to consumers only, i.e. natural persons intending to use this product neither for their commercial activities nor for any other self-employed activities. These warranty terms regulate additional warranty services, which the manufacturer mentioned below promises to buyers of its new products in addition to their statutory rights of guarantee. Your statutory guarantee claims are not affected by this guarantee. Our guarantee is free of charge to you.
2. The warranty services cover only defects due to material or manufacturing faults on a product which you have bought from the manufacturer mentioned below and are limited to either the rectification of said defects on the product or the replacement of the product, whichever we prefer.
Please note that our devices are not designed for use in commercial, trade or professional applications. A guarantee contract will not be created if the device has been used by commercial, trade or industrial business or has been exposed to similar stresses during the guarantee period.
3. The following are not covered by our guarantee:
 - Damage to the device caused by a failure to follow the assembly instructions or due to incorrect installation, a failure to follow the operating instructions (for example connecting it to an incorrect mains voltage or current type) or a failure to follow the maintenance and safety instructions or by exposing the device to abnormal environmental conditions or by lack of care and maintenance.
 - Damage to the device caused by abuse or incorrect use (for example overloading the device or the use of unapproved tools or accessories), ingress of foreign bodies into the device (such as sand, stones or dust, transport damage), the use of force or damage caused by external forces (for example by dropping it).
 - Damage to the device or parts of the device caused by normal or natural wear or tear or by normal use of the device.
4. The guarantee is valid for a period of 24 months starting from the purchase date of the device. Guarantee claims should be submitted before the end of the guarantee period within two weeks of the defect being noticed. No guarantee claims will be accepted after the end of the guarantee period. The original guarantee period remains applicable to the device even if repairs are carried out or parts are replaced. In such cases, the work performed or parts fitted will not result in an extension of the guarantee period, and no new guarantee will become active for the work performed or parts fitted. This also applies if an on-site service is used.
5. To make a claim under the guarantee, please register the defective device at: www.Einhell-Service.com. Please keep your bill of purchase or other proof of purchase for the new device. Devices that are returned without proof of purchase or without a rating plate shall not be covered by the guarantee, because appropriate identification will not be possible. If the defect is covered by our guarantee, then the item in question will either be repaired immediately and returned to you or we will send you a new replacement.

Of course, we are also happy offer a chargeable repair service for any defects which are not covered by the scope of this guarantee or for units which are no longer covered. To take advantage of this service, please send the device to our service address.

Also refer to the restrictions of this warranty concerning wear parts, consumables and missing parts as set out in the service information in these operating instructions.

