

D	Originalbetriebsanleitung Akku-Handstaubsauger	FIN	Alkuperäiskäyttöohje Akkukäyttöinen käsipölynimuri
GB	Original operating instructions Cordless Hand-Held Vacuum Cleaner	SLO	Originalna navodila za uporabo Baterijskega ročnega sesalca za prah
F	Instructions d'origine Aspirateur à main sans fil	H	Eredeti használati utasítás Akku-kéziporszívó
I	Istruzioni per l'uso originali Aspirapolvere a batteria	RO	Instrucțiuni de utilizare originale Aspirator de mână cu baterie
DK/ N	Original betjeningsvejledning Håndstøvsuger med oplader	GR	Πρωτότυπες Οδηγίες χρήσης Σκούπα χεριού με μπαταρία
S	Original-bruksanvisning Batteridrivnen handdammsugare	P	Manual de instruções original Aspirador portátil sem fio
CZ	Originální návod k obsluze Akumulátorový ruční vysavač	HR/ BIH	Originalne upute za uporabu Baterijskog ručnog usisavača prašine
SK	Originálny návod na obsluhu Akumulátorového ručného vysávača	RS	Originalna uputstva za upotrebu Akumulatorski ručni usisavač
NL	Originele handleiding Accu-handstofzuiger	PL	Instrukcją oryginalną Odkurzacz ręczny akumulatorowy
E	Manual de instrucciones original Aspirador de mano con batería	TR	Orijinal Kullanma Talimatı Akülü el süpürgesi
		EE	Originaalkasutusjuhend Akuga käsitolmuimeja

13



Art.-Nr.: 23.471.90

I.-Nr.: 21011

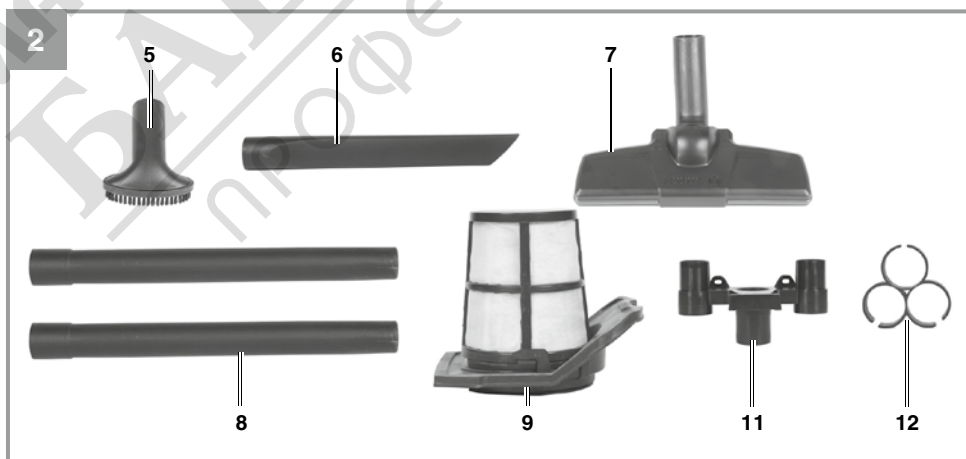
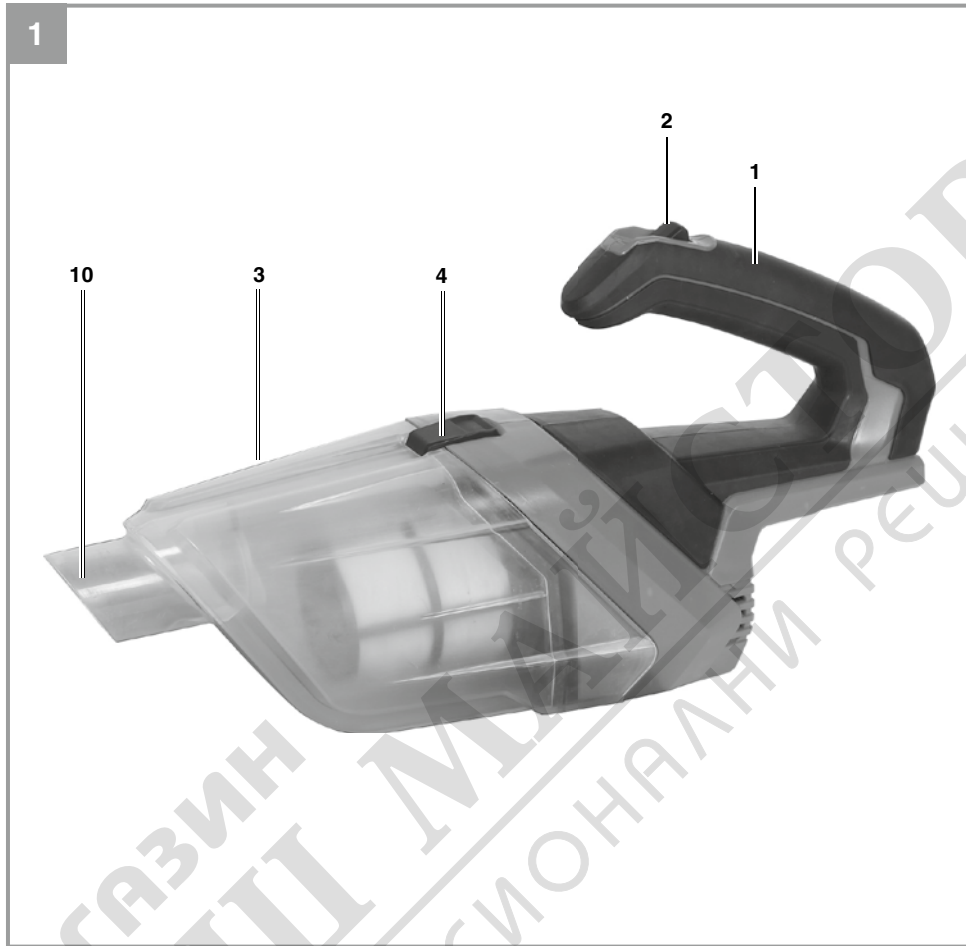

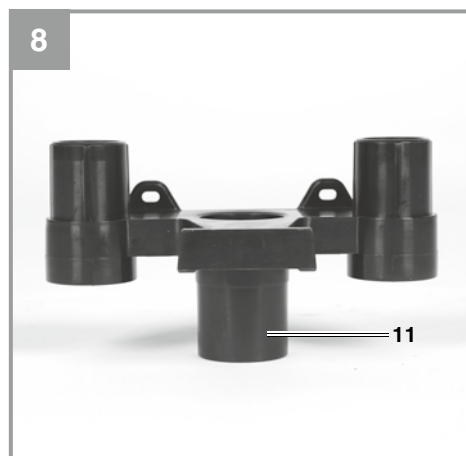
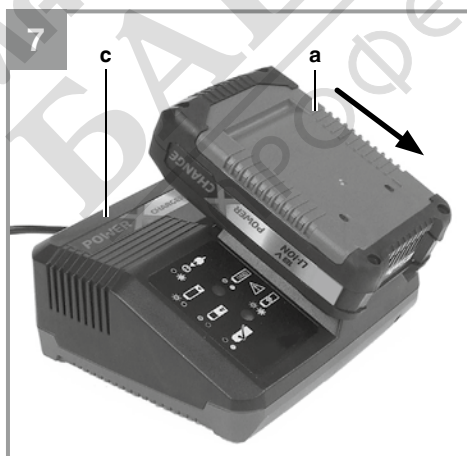
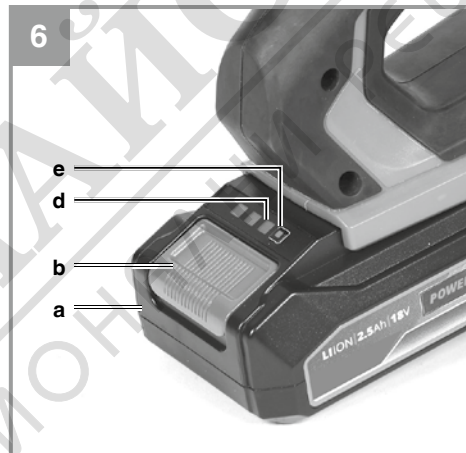
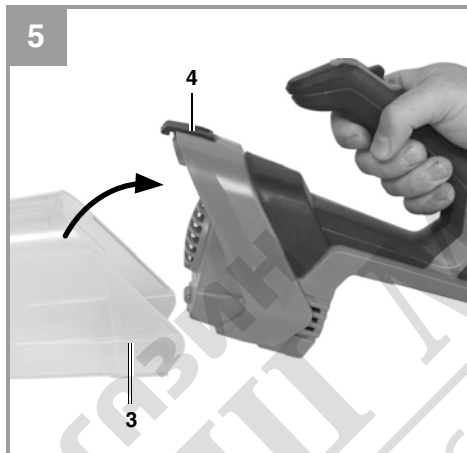
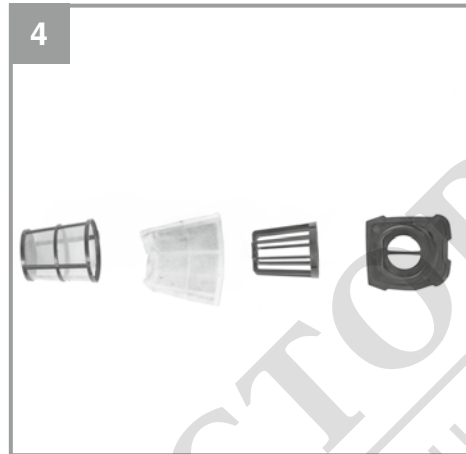
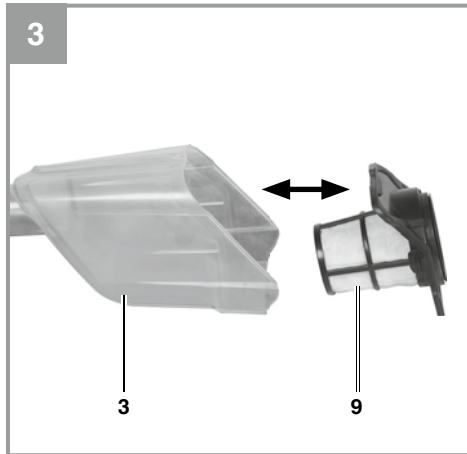

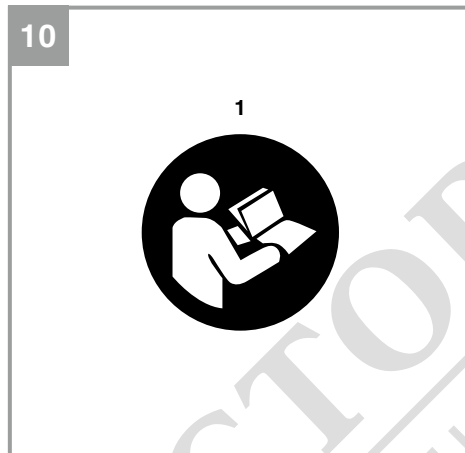

МАГАЗИН
БАШ МАЙСТОРА[®]
ПРОФЕСІОНАЛНИ РЕШЕННЯ

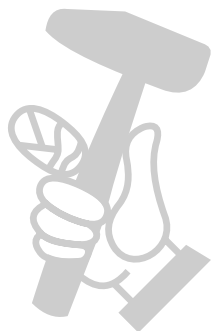

Danger!

When using the equipment, a few safety precautions must be observed to avoid injuries and damage. Please read the complete operating instructions and safety regulations with due care. Keep this manual in a safe place, so that the information is available at all times. If you give the equipment to any other person, hand over these operating instructions and safety regulations as well. We cannot accept any liability for damage or accidents which arise due to a failure to follow these instructions and the safety instructions.

Explanation of the symbols used (see Fig. 10)

1. **Danger!** - Read the operating instructions to reduce the risk of injury.

1. Safety regulations

The corresponding safety information can be found in the enclosed booklet.

Danger!**Read all safety regulations and instructions.**

Any errors made in following the safety regulations and instructions may result in an electric shock, fire and/or serious injury.

Keep all safety regulations and instructions in a safe place for future use.

- Never vacuum the following: Burning matches, smoldering ash and cigarette butts, combustible, caustic, inflammable or explosive substances, vapor or liquids.
- This equipment is not suitable for vacuuming dust which can be harmful to health.
- Store the equipment in a dry indoor location.
- Never use the equipment if it is damaged.
- Have the equipment serviced only by an authorized after sales service outlet.
- Use the equipment only to carry out work for which has been designed.
- Take extra care when cleaning steps.
- Use only genuine accessories and spare parts.

This equipment can be used by children of 8 years and older and by people with limited physical, sensory or mental capacities or those with no experience and knowledge if they are supervised or have received instruction in how to use the equipment safely and understand the dangers which result from such use. Children are not allowed to play with the equipment. Unless supervised,

children are not allowed to clean the equipment or carry out user-level maintenance work.

Do not short circuit the equipment.

Information on the charger: If the power cable for this equipment is damaged, it must be replaced by the manufacturer or OEM after-sales service or by similarly trained personnel to prevent hazards. The equipment may only be used together with the appropriate rechargeable batteries and the charger from the Power X-Change series.

2. Layout and items supplied**2.1 Layout (Fig. 1-2)**

1. Handle
2. On/Off switch
3. Tank
4. Locking switch for tank
5. Upholstery nozzle
6. Crevice nozzle
7. Combination nozzle
8. Extension tube 2x
9. Filter
10. Intake opening
11. Wall holder
12. Accessory holder

2.2 Items supplied

Please check that the article is complete as specified in the scope of delivery. If parts are missing, please contact our service center or the sales outlet where you made your purchase at the latest within 5 working days after purchasing the product and upon presentation of a valid bill of purchase. Also, refer to the warranty table in the service information at the end of the operating instructions.

- Open the packaging and take out the equipment with care.
- Remove the packaging material and any packaging and/or transportation braces (if available).
- Check to see if all items are supplied.
- Inspect the equipment and accessories for transport damage.
- If possible, please keep the packaging until the end of the guarantee period.

Danger!

The equipment and packaging material are not toys. Do not let children play with plastic bags, foils or small parts. There is a danger of

swallowing or suffocating!

- Upholstery nozzle
- Crevice nozzle
- Combination nozzle
- Extension tube 2x
- Filter
- Wall holder
- Original operating instructions
- Safety information
- Accessory holder

3. Proper use

The vacuum cleaner is designed for dry vacuuming using the appropriate filter. The equipment is not suitable for the vacuuming of combustible, explosive or harmful substances.

The equipment is to be used only for its prescribed purpose. Any other use is deemed to be a case of misuse. The user / operator and not the manufacturer will be liable for any damage or injuries of any kind caused as a result of this.

Please note that our equipment has not been designed for use in commercial, trade or industrial applications. Our warranty will be voided if the machine is used in commercial, trade or industrial businesses or for equivalent purposes.

4. Technical data

Motor power supply: 18 V DC
 Tank volume: 0.54 l
 Weight: 0.85 kg

Important!

The equipment is supplied without rechargeable batteries and without a charger and is allowed to be used only with the lithium-ion batteries of the Power X-Change series!

The lithium-ion batteries of the Power X-Change series are allowed to be charged only with Power-X chargers.

Suitable rechargeable batteries and chargers from the Power X-Change range are for example:

- Rechargeable battery: Power X-Change 1.5
- Rechargeable battery: Power X-Change 5.2
- Charger: Power X-Charger 3A

- Charger: Power X-Charger

5. Before starting the equipment**Warning!**

Always remove the battery pack before making adjustments to the equipment.

5.1 Assembling the equipment**Fitting the nozzles (Fig. 1-2)**

The nozzles (5, 6, 7) can be fitted to the vacuum cleaner either directly on the intake opening (10) or via the extension tubes (8).

Fitting/removing the filter (Fig. 1-4)

Press the locking switch (4) and remove the tank at the same time (3). You can then take the filter (9) out of the tank (3) (Fig. 3).

The filter (9) must be completely taken apart to enable it to be thoroughly cleaned (Fig. 4).

After cleaning, fit the filter (9) back in the tank (3) (Fig. 3). Then fit the tank (3) back on the vacuum cleaner (Fig. 5).

Fitting the wall holder (Fig. 8)

Fit the wall holder (11) as shown in Fig. 8.

Suitable fastening materials such as screws etc. (Ø 4 mm) are available from your dealer.

The holder provides a practical means of storing the handheld vacuum cleaner after use (Fig. 9).

Important!

The wall holder is only suitable for use with Einhell cordless handheld vacuum cleaners. It is not suitable for bigger loads!

5.2 Suction nozzles**Combination nozzle (Fig. 2)**

The combination nozzle (7) is for vacuuming solids over medium to large areas.

Crevice nozzle (Fig. 2)

The crevice nozzle (6) is designed for vacuuming solids in corners, edges and other areas that are difficult to access.

Upholstery nozzle (Fig. 2)

The upholstery nozzle (5) is specially designed for vacuuming solids on upholstery and carpets.

5.3 Charging the battery (Fig. 6-7)

1. Take the battery pack out of the equipment. Do this by pressing the side pushlock buttons.
2. Check that your mains voltage is the same as that marked on the rating plate of the battery charger. Insert the power plug of the charger (c) into the socket outlet. The green LED will then begin to flash.
3. Insert the battery pack (a) into the battery charger (c).
4. In the section entitled „Charger indicator“ you will find a table with an explanation of the LED indicator on the charger.

The battery pack can become a little warm during the charging. This is normal.

If the battery pack fails to charge, check:

- whether there is voltage at the socket outlet
- whether there is good contact at the charging contacts

If the battery pack still fails to charge, send

- the charging unit
- and the battery pack

to our customer service center.

To ensure that items are properly packaged and delivered when you send them to us, please contact our customer service or the point of sale at which the equipment was purchased.

When shipping or disposing of batteries and cordless tools, always ensure that they are packed individually in plastic bags to prevent short circuits and fires.

To ensure that the battery pack provides long service, you should take care to recharge it promptly. You must recharge the battery pack when you notice that the performance of the device drops. Never allow the battery pack to become fully discharged. This will cause it to develop a defect.

5.4 Battery capacity indicator (Fig. 6/Item d)

Press the button for the battery capacity indicator (e). The battery capacity indicator (d) shows the charge status of the battery using 3 LEDs.

All 3 LEDs are lit:

The battery is fully charged.

2 or 1 LED(s) are lit:

The battery has an adequate remaining charge.

1 LED flashes:

The battery is empty, recharge the battery.

All LEDs blink:

The battery temperature is too low. Remove the battery from the equipment, keep it at room temperature for one day. If the fault reoccurs, this means that the rechargeable battery has undergone exhaustive discharge and is defective. Remove the battery from the equipment. Never use or charge a defective battery.

6. Operation

On/Off switch (Fig. 1/Item 2)

Switch position Moved in: Off

Switch position Middle (ECO) - Normal suction power for cleaning e.g. hard floors or when a longer running time is needed.

Switch position Moved out (BOOST): High suction power for cleaning e.g. carpets and when more cleaning power is preferred.

7. Replacing the power cable

Hazard!

Always pull out the battery pack before starting any cleaning work.

7.1 Cleaning

- Keep all safety devices, air vents and the motor housing free of dirt and dust as far as possible.
- We recommend cleaning the equipment immediately each time after use.

7.2 Cleaning the tank (3)

The tank can be cleaned with a damp cloth and some soft soap or under running water, depending on the amount of dirt.

7.3 Cleaning the filter (9)

Clean the filter (9) under running water and allow it to air-dry.

7.4 Maintenance

At regular intervals and before each use, check that the filters in the vacuum cleaner are securely fitted. If you are not going to use the equipment for an extended period of time, remove the battery.

7.5 Ordering replacement parts:

Please quote the following data when ordering replacement parts:

- Type of machine
- Article number of the machine
- Identification number of the machine
- Replacement part number of the part required

For our latest prices and information please go to www.Einhell-Service.com

8. Disposal and recycling

The equipment is supplied in packaging to prevent it from being damaged in transit. The raw materials in this packaging can be reused or recycled. The equipment and its accessories are made of various types of material, such as metal and plastic. Never place defective equipment in your household refuse. The equipment should be taken to a suitable collection center for proper disposal. If you do not know the whereabouts of such a collection point, you should ask in your local council offices.

9. Storage

Store the equipment and accessories in a dark and dry place at above freezing temperature. The ideal storage temperature is between 5 and 30 °C. Store the electric tool in its original packaging.

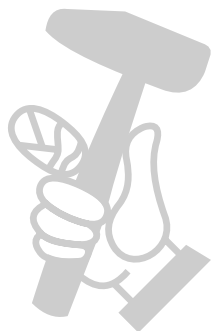

10. Charger indicator

Indicator status		Explanations and actions
Red LED	Green LED	
Off	Flashing	<p>Ready for use The charger is connected to the mains and is ready for use; there is no battery pack in the charger</p>
On	Off	<p>Charging The charger is charging the battery pack in quick charge mode. The charging times are shown directly on the charger. Important! The actual charging times may vary slightly from the stated charging times depending on the existing battery charge.</p>
Off	On	<p>The battery is charged and ready for use. (READY TO GO) The unit then changes over to gentle charging mode until the battery is fully charged. To do this, leave the rechargeable battery on the charger for approx. 15 minutes longer. Action: Take the battery pack out of the charger. Disconnect the charger from the mains supply.</p>
Flashing	Off	<p>Adapted charging The charger is in gentle charging mode. For safety reasons the charging is performed less quickly and takes more time. The reasons can be: - The rechargeable battery has not been used for a very long time. - The battery temperature is outside the ideal range. Action: Wait for the charging to be completed; you can still continue to charge the battery pack.</p>
Flashing	Flashing	<p>Fault Charging is no longer possible. The battery pack is defective. Action: Never charge a defective battery pack. Take the battery pack out of the charger.</p>
On	On	<p>Temperature fault The battery pack is too hot (e.g. due to direct sunshine) or too cold (below 0° C). Action: Remove the battery pack and keep it at room temperature (approx. 20° C) for one day .</p>



For EU countries only

Never place any electric power tools in your household refuse.

To comply with European Directive 2012/19/EC concerning old electric and electronic equipment and its implementation in national laws, old electric power tools have to be separated from other waste and disposed of in an environment-friendly fashion, e.g. by taking to a recycling depot.

Recycling alternative to the return request:

As an alternative to returning the equipment to the manufacturer, the owner of the electrical equipment must make sure that the equipment is properly disposed of if he no longer wants to keep the equipment. The old equipment can be returned to a suitable collection point that will dispose of the equipment in accordance with the national recycling and waste disposal regulations. This does not apply to any accessories or aids without electrical components supplied with the old equipment.

Please note that batteries and lamps (e.g. light bulbs) must be removed from the tool before it is disposed of.

The reprinting or reproduction by any other means, in whole or in part, of documentation and papers accompanying products is permitted only with the express consent of the Einhell Germany AG.

Subject to technical changes

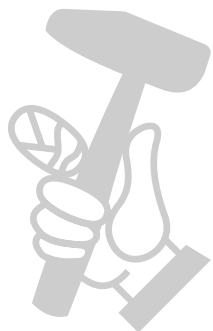

Service information

We have competent service partners in all countries named on the guarantee certificate whose contact details can also be found on the guarantee certificate. These partners will help you with all service requests such as repairs, spare and wearing part orders or the purchase of consumables.

Please note that the following parts of this product are subject to normal or natural wear and that the following parts are therefore also required for use as consumables.

Category	Example
Wear parts*	Combination nozzle, crevice nozzle, upholstery nozzle, battery, etc.
Consumables*	Filter
Missing parts	

* Not necessarily included in the scope of delivery!

In the event of defects or faults, please register the problem on the internet at www.Einhell-Service.com. Please ensure that you provide a precise description of the problem and answer the following questions in all cases:

- Did the equipment work at all or was it defective from the beginning?
- Did you notice anything (symptom or defect) prior to the failure?
- What malfunction does the equipment have in your opinion (main symptom)? Describe this malfunction.



Warranty certificate

Dear Customer,

All of our products undergo strict quality checks to ensure that they reach you in perfect condition. In the unlikely event that your device develops a fault, please contact our service department at the address shown on this guarantee card. You can also contact us by telephone using the service number shown.

Please note the following terms under which guarantee claims can be made:

1. These guarantee terms apply to consumers only, i.e. natural persons intending to use this product neither for their commercial activities nor for any other self-employed activities. These warranty terms regulate additional warranty services, which the manufacturer mentioned below promises to buyers of its new products in addition to their statutory rights of guarantee. Your statutory guarantee claims are not affected by this guarantee. Our guarantee is free of charge to you.
2. The warranty services cover only defects due to material or manufacturing faults on a product which you have bought from the manufacturer mentioned below and are limited to either the rectification of said defects on the product or the replacement of the product, whichever we prefer.
Please note that our devices are not designed for use in commercial, trade or professional applications. A guarantee contract will not be created if the device has been used by commercial, trade or industrial business or has been exposed to similar stresses during the guarantee period.
3. The following are not covered by our guarantee:
 - Damage to the device caused by a failure to follow the assembly instructions or due to incorrect installation, a failure to follow the operating instructions (for example connecting it to an incorrect mains voltage or current type) or a failure to follow the maintenance and safety instructions or by exposing the device to abnormal environmental conditions or by lack of care and maintenance.
 - Damage to the device caused by abuse or incorrect use (for example overloading the device or the use of unapproved tools or accessories), ingress of foreign bodies into the device (such as sand, stones or dust, transport damage), the use of force or damage caused by external forces (for example by dropping it).
 - Damage to the device or parts of the device caused by normal or natural wear or tear or by normal use of the device.
4. The guarantee is valid for a period of 24 months starting from the purchase date of the device. Guarantee claims should be submitted before the end of the guarantee period within two weeks of the defect being noticed. No guarantee claims will be accepted after the end of the guarantee period. The original guarantee period remains applicable to the device even if repairs are carried out or parts are replaced. In such cases, the work performed or parts fitted will not result in an extension of the guarantee period, and no new guarantee will become active for the work performed or parts fitted. This also applies if an on-site service is used.
5. To make a claim under the guarantee, please register the defective device at: www.Einhell-Service.com. Please keep your bill of purchase or other proof of purchase for the new device. Devices that are returned without proof of purchase or without a rating plate shall not be covered by the guarantee, because appropriate identification will not be possible. If the defect is covered by our guarantee, then the item in question will either be repaired immediately and returned to you or we will send you a new replacement.

Of course, we are also happy offer a chargeable repair service for any defects which are not covered by the scope of this guarantee or for units which are no longer covered. To take advantage of this service, please send the device to our service address.

Also refer to the restrictions of this warranty concerning wear parts, consumables and missing parts as set out in the service information in these operating instructions.

