

<b>D</b>	<b>Originalbetriebsanleitung Akku-Gartenpumpe</b>	<b>FIN</b>	<b>Alkuperäiskäyttöohje Akku-puutarhapumppu</b>
<b>GB</b>	<b>Original operating instructions Cordless garden pump</b>	<b>SLO</b>	<b>Originalna navodila za uporabo Akumulatorska vrtna črpalka</b>
<b>F</b>	<b>Instructions d'origine Pompe de jardin sans fil</b>	<b>H</b>	<b>Eredeti használati utasítás Akkus-kerti szivattyú</b>
<b>I</b>	<b>Istruzioni per l'uso originali Pompa autoadescante a batteria</b>	<b>RO</b>	<b>Instrucțiuni de utilizare originale Pompă de grădină cu acumulator</b>
<b>DK/ N</b>	<b>Original betjeningsvejledning Akku-havepumpe</b>	<b>GR</b>	<b>Πρωτότυπες Οδηγίες χρήσης Αντλία κήπου, με μπαταρία</b>
<b>S</b>	<b>Original-bruksanvisning Batteridrivnen trädgårdspump</b>	<b>P</b>	<b>Manual de instrucções original Bomba de jardim sem fio</b>
<b>CZ</b>	<b>Originální návod k obsluze Zahradní čerpadlo</b>	<b>HR/ BIH</b>	<b>Originalne upute za uporabu Akumulatorska pumpa za vrt</b>
<b>SK</b>	<b>Originálny návod na obsluhu Záhradné čerpadlo</b>	<b>RS</b>	<b>Originalna uputstva za upotrebu Akumulatorska pumpa za baštu</b>
<b>NL</b>	<b>Originele handleiding Accu-tuin pomp</b>	<b>PL</b>	<b>Instrukcją oryginalną Akumulatorowa pompa ogrodowa</b>
<b>E</b>	<b>Manual de instrucciones original Bomba para jardín inalámbrica</b>	<b>TR</b>	<b>Orijinal Kullanma Talimatı Akülü Bahçe Pompası</b>
		<b>EE</b>	<b>Originaalkasutusjuhend Akuga aiapump</b>

13



Art.-Nr.: 41.804.30

I.-Nr.: 21012

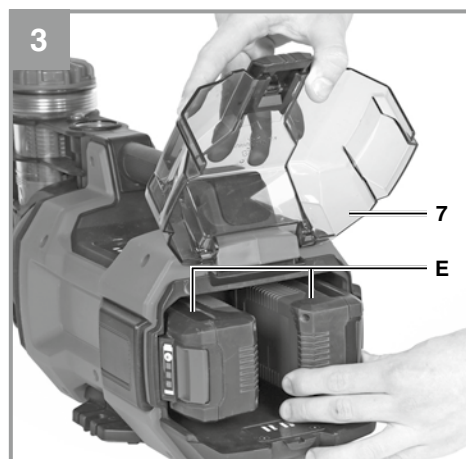
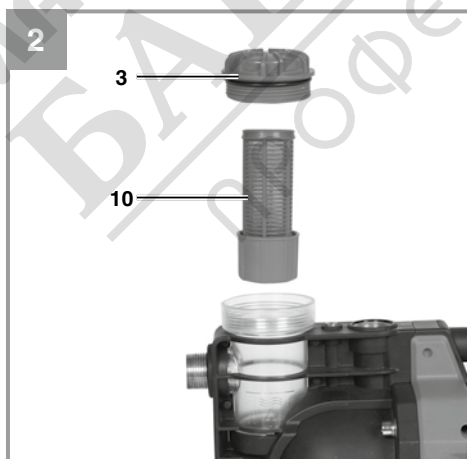
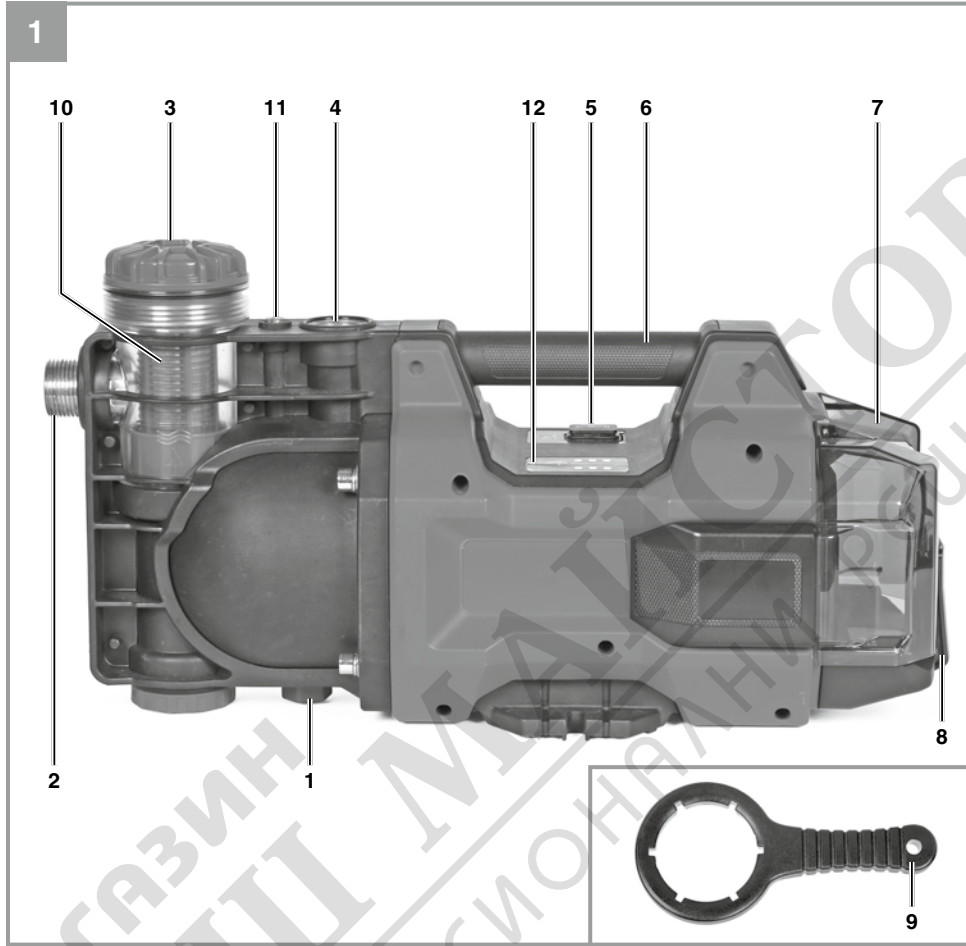

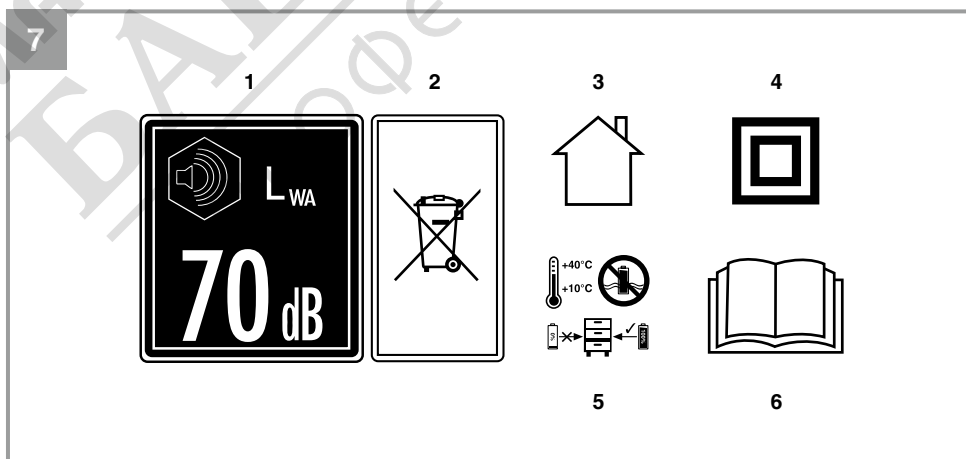
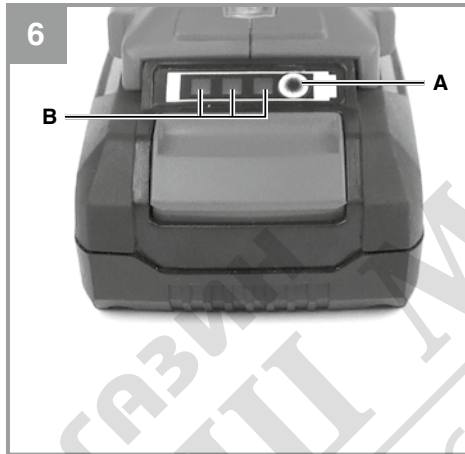
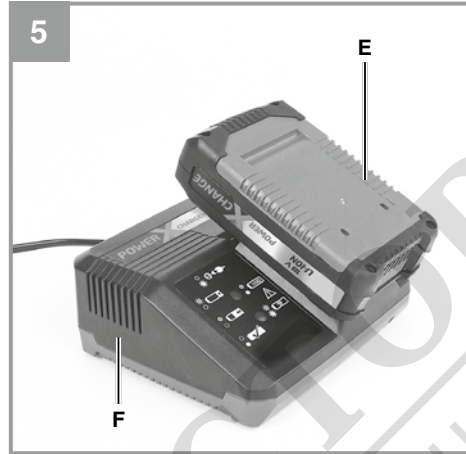
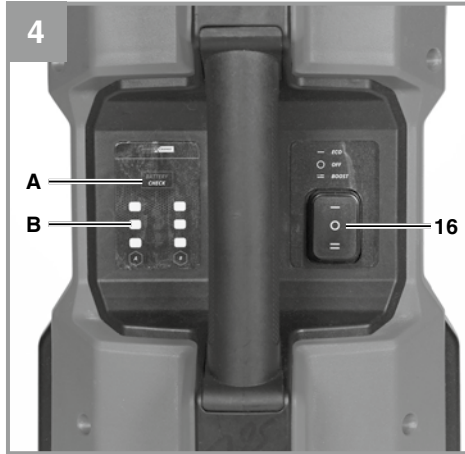

**Danger!**

When using the equipment, a few safety precautions must be observed to avoid injuries and damage. Please read the complete operating instructions and safety regulations with due care. Keep this manual in a safe place, so that the information is available at all times. If you give the equipment to any other person, hand over these operating instructions and safety regulations as well. We cannot accept any liability for damage or accidents which arise due to a failure to follow these instructions and the safety instructions.

**1. Safety regulations**

The corresponding safety information can be found in the enclosed booklet.

**Warning!**

**Read all the safety information, instructions, illustrations and technical data provided on or with this power tool.** Failure to adhere to the following instructions may result in electric shock, fire and/or serious injury.

**Keep all the safety information and instructions in a safe place for future use.**

This equipment can be used by children of 8 years and older and by people with limited physical, sensory or mental capacities or those with no experience and knowledge if they are supervised or have received instruction in how to use the equipment safely and understand the dangers which result from such use. Children are not allowed to play with the equipment. Unless supervised, children are not allowed to clean the equipment and carry out user-level maintenance work.

**The equipment is not designed for use in swimming pools and paddling pools of any kind or other bodies of water in which people or animals may be present during operation. It is prohibited to operate the equipment if a person or animal is in the danger area. Ask your electrician!**

**Danger!**

- Always inspect the equipment visually before using it. Do not use the equipment if safety devices are damaged or worn. Never disable any safety devices.
- Use the equipment only for the purposes indicated in these operating instructions.
- You are responsible for safety in the operating

area.

- Remove the batteries before starting any work on the equipment.
- Do not expose the equipment to a direct jet of water.
- The operator is responsible for complying with local safety and installation regulations. (Ask an electrician if you are in any doubt.)
- The user is required to take suitable measures (e.g. installing an alarm system or a reserve pump, etc.) to prevent damage arising as a result of flooded rooms in the event of faults with the equipment.
- In the event of a failure of the equipment, repair work may only be carried out by an electrician or by ISC after-sales service personnel.
- The unit must never run dry or be used when the intake line is closed fully. The manufacturer's warranty does not cover damage caused to the unit as a result of running it dry.
- The pump must not be used to operate swimming pools.
- The equipment must not be installed in the drinking water pipe line.

**General safety information for lithium-ion rechargeable batteries:**

**For the special safety information on lithium-ion rechargeable batteries please refer to the booklet included in delivery.**

**Explanation of the symbols used (see Fig. 7)**

1. Guaranteed sound power level
2. Dispose of batteries correctly
3. For use in dry rooms only
4. Safety class II
5. Store the batteries only in dry rooms with an ambient temperature of +10°C to +40°C. Place only charged batteries in storage (charged at least 40%).
6. "Hazard - Read the operating instructions to reduce the risk of injury"

## 2. Layout and items supplied

### 2.1 Layout

1. Water drain screw
2. Intake connection
3. Coarse filter cap
4. Discharge connection
5. On/Off/Pump setting switch
6. Carry-handle
7. Battery cover
8. Buckle, prong-end
9. Key for coarse filter cap
10. Coarse filter
11. Ventilation screw
12. Battery charge level indicator

### 2.2 Items supplied

Please check that the article is complete as specified in the scope of delivery. If parts are missing, please contact our service center or the sales outlet where you made your purchase at the latest within 5 working days after purchasing the product and upon presentation of a valid bill of purchase. Also, refer to the warranty table in the service information at the end of the operating instructions.

- Open the packaging and take out the equipment with care.
- Remove the packaging material and any packaging and/or transportation braces (if available).
- Check to see if all items are supplied.
- Inspect the equipment and accessories for transport damage.
- If possible, please keep the packaging until the end of the guarantee period.

### Danger!

**The equipment and packaging material are not toys. Do not let children play with plastic bags, foils or small parts. There is a danger of swallowing or suffocating!**

- Cordless garden pump
- Key for coarse filter cap
- Original operating instructions
- Safety instructions

## 3. Proper use

### Range of applications:

- For irrigating and watering landscaped areas, vegetable beds and gardens
- For operating lawn sprinklers
- With coarse filter for drawing water from ponds, streams, rainwater butts, rainwater cisterns and wells
- For supplying service water

### Transport media:

- For the pumping of clear water (freshwater), rainwater and mild suds/service water.
- The maximum temperature of the fluid must not exceed +35°C if the unit is operated permanently.
- Do not use the equipment to pump inflammable, gassing or explosive fluids.
- The pumping of aggressive liquids (acids, alkalis, silo seepage etc.) as well as liquids with abrasive substances (sand) must likewise be avoided.
- This equipment is not designed to convey drinking water.

The equipment is to be used only for its prescribed purpose. Any other use is deemed to be a case of misuse. The user / operator and not the manufacturer will be liable for any damage or injuries of any kind caused as a result of this.

Please note that our equipment has not been designed for use in commercial, trade or industrial applications. Our warranty will be voided if the machine is used in commercial, trade or industrial businesses or for equivalent purposes.

## 4. Technical data

Voltage .....	2 x 18 V d.c.
Pressure connector .....	approx. 33.3 mm (G1 female thread)
Suction connection .....	approx. 33.3 mm (R1 male thread)
Max. pumping rate .....	3000 l/h
Max. delivery head .....	28 m
Delivery pressure max. ....	0.28 MPa (2.8 bar)
Suction height max. ....	6 m
Water temperature max. ....	35°C
Measured sound power level .....	67.6 dB (A)
Uncertainty .....	2.26 dB

Guaranteed sound power level ..... 70 dB (A)  
 Protection ..... IPX4

### Important!

The equipment is supplied without batteries and without a charger and is allowed to be used only with the lithium-ion batteries of the Power X-Change series!

The lithium-ion batteries of the Power X-Change series are allowed to be charged only with the Power-X charger.

## 5. Before using the equipment

### The equipment is supplied without batteries and without a charger.

As a basic principle, we recommend the use of a preliminary filter and a suction set with suction hose, intake cage and non-return valve, in order to prevent long priming periods and unnecessary damage to the pump as a result of stones and solid foreign bodies.

#### 5.1 Connecting the intake line

- Fasten the suction hose (at least approx. 19 mm (3/4") plastic hose with spiral reinforcement) to the suction connection approx. 33.3 mm (R1 male thread) of the equipment either directly or via a threaded nipple.
- The suction hose used should be equipped with an intake valve. If the intake valve cannot be used, a non-return valve should be installed in the intake line.
- Position the intake line so that it rises from the water withdrawal point to the equipment. Avoid positioning the intake line higher than the pump, as this would delay the escape of air bubbles from the intake line and impede the priming process.
- Install the intake and discharge lines in such a way that they do not exert any mechanical pressure on the equipment.
- The intake valve should be low enough in the water to ensure that if the water level falls, the unit will not run dry.
- A leaking intake line will draw in air and therefore not draw in any water.
- Prevent the intake of foreign bodies (sand, etc.). If necessary, install a coarse filter for this purpose.

#### 5.2 Connecting the discharge line

- The discharge line (min. approx. 19 mm (3/4") must be connected to the female thread discharge line (approx. 33.3 mm (G1 female thread)) connector of the equipment either directly or with the aid of a threaded nipple.
- You can also use a pressure hose of approx. 13 mm (1/2") with the relevant couplings. The pump rate is reduced when using the smaller discharge line.
- During the priming process, the shut-off devices present in the discharge line (spray nozzles, valves, etc.) must be completely open so that the air in the intake line can escape freely.

#### 5.3 Preparing the pump (Fig. 2)

- Open the ventilation screw (4) so that air can escape when the pump housing is being filled.
- Use the supplied wrench (9) to unscrew the coarse filter cap (3) and then remove the coarse filter (10). Now you can fill the pump housing with water via the coarse filter cap (3). Filling the intake line will accelerate the priming process.
- Assemble in reverse order.

#### 5.4 Fitting the battery (Fig. 3)

Open the battery cover.

Press the side pushlock button of the battery pack as shown in Fig. 3 and push the battery pack into the mount provided. When the battery is positioned as in Fig. 3, make sure that the pushlock button latches in place! To remove the battery pack, proceed in reverse order.

### Important!

Only one battery is needed to operate the cordless garden pump. You can insert the battery on either the left or right side. For a longer running time you can equip the cordless garden pump with 2 batteries (of the same or different capacities). The cordless garden pump will begin by using the battery on the left side, before automatically switching over to the battery on the right side when required.

#### 5.5 Charging the battery (Figure 5)

1. Take the battery pack out of the equipment. Do this by pressing the pushlock button.
2. Check that your mains voltage is the same as that marked on the rating plate of the battery charger. Insert the power plug of the charger

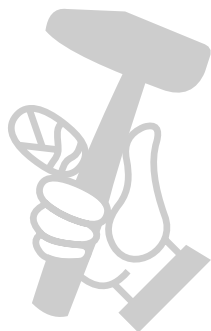

(F) into the socket outlet. The green LED will then begin to flash.

3. Insert the battery pack (E) into the battery charger (F).
4. In the section entitled „Charger indicator“ you will find a table with an explanation of the LED indicator on the charger.

The battery pack can become a little warm during the charging. This is normal.

If the battery pack fails to charge, check:

- whether there is voltage at the socket outlet
- whether there is good contact at the charging contacts

If the battery pack still fails to charge, send

- the charging unit
- and the battery pack

to our customer service center.

**To ensure that items are properly packaged and delivered when you send them to us, please contact our customer service or the point of sale at which the equipment was purchased.**

**When shipping or disposing of batteries and cordless tools, always ensure that they are packed individually in plastic bags to prevent short circuits and fires.**

To ensure that the battery pack provides long service, you should take care to recharge it promptly. You must recharge the battery pack when you notice that the performance of the device drops. Never allow the battery pack to become fully discharged. This will cause it to develop a defect.

#### 5.6 Battery capacity indicator (Fig. 4/6)

You can read off the battery charge level from the battery itself (Fig. 6) as well as from the cordless garden pump (Fig. 4).

The battery charge level can be shown on the cordless garden pump separately for each battery.

Press the button for the battery capacity indicator (Item A). The battery capacity indicator (Item B) shows the charge status of the battery using 3 LEDs.

#### All 3 LEDs are lit:

The battery is fully charged.

#### 2 or 1 LED(s) are lit:

The battery has an adequate remaining charge.

#### 1 LED flashes:

The battery is empty, recharge the battery.

#### All LEDs blink:

The battery temperature is too low. Remove the battery from the equipment, keep it at room temperature for one day. If the fault reoccurs, this means that the rechargeable battery has undergone exhaustive discharge and is defective. Remove the battery from the equipment. Never use or charge a defective battery.

## 6. Operation

### 6.1 On/Off/Pump setting switch (Fig. 4/Item 5)

Switch position 0: Off

Switch position I: Pump setting 1 (ECO)

Switch position II: Pump setting 2 (BOOST)

#### Important!

Selecting pump setting 2 will increase the maximum delivery pressure and the maximum delivery rate, but it will also reduce the maximum operating time of the battery as the result.

### 6.2 Using for the first time

- Install the equipment on a solid and level surface.
- All the shut-off devices in the discharge line (spray nozzle, valves etc.) must be fully opened during intake in order to permit all air to escape from the intake line.
- The intake process starts automatically after you have pressed the On/Off/Pump setting switch (5). Water can be suctioned in for up to 5 minutes (maximum suction height).
- If the pump is removed after use, it is essential that it is filled with water again the next time it is connected and started.

Switch the pump off again after use by pressing the On/Off/Pump setting switch (5) again and allow the pump to cool down.

## 7. Cleaning, maintenance and ordering spare parts

The equipment almost completely maintenance free. In order to ensure a long service life, however, we recommend regular checks and product care.

### **Danger!**

Always remove the batteries before starting any cleaning work.

### 7.1 Maintenance

- If the equipment becomes clogged, connect the discharge line to the water line and disconnect the intake line. Open the water line. Switch on the equipment several times for approx. two seconds. This should resolve the majority of clog-related problems.
- There are no other parts inside the equipment which require maintenance.

### 7.2 Cleaning the coarse filter insert

- Clean the coarse filter insert at regular intervals, and replace it if necessary.
- Remove the coarse filter cap (3) and the coarse filter (10) (Fig. 2).
- Clean the coarse filter by tapping it on a flat surface.
- Wash the coarse filter under flowing, clear water.
- In cases of stubborn dirt, first wash with soapy water, then rinse with clear water and leave to dry in the air.
- Do not use abrasive cleaning agents or petrol to clean the coarse filter.
- Assemble in reverse order.

### 7.3 Ordering replacement parts:

Please quote the following data when ordering replacement parts:

- Type of machine
- Article number of the machine
- Identification number of the machine
- Replacement part number of the part required

For our latest prices and information please go to [www.Einhell-Service.com](http://www.Einhell-Service.com)

## 8. Disposal and recycling

The equipment is supplied in packaging to prevent it from being damaged in transit. The raw materials in this packaging can be reused or recycled. The equipment and its accessories are made of various types of material, such as metal and plastic. Never place defective equipment in your household refuse. The equipment should be taken to a suitable collection center for proper disposal. If you do not know the whereabouts of such a collection point, you should ask in your local council offices.

## 9. Storage

- Store the equipment and its accessories in a dark and dry place at above freezing temperature. The ideal storage temperature is between 5 and 30 °C. Store the equipment in its original packaging.
- Before lengthy periods of inactivity or winter storage rinse the pump thoroughly, empty it completely and store it in a dry place.
- The unit must be completely drained before it is subjected to frost.
- After relatively long periods of storage, switch on and off briefly to check whether the rotor is turning properly.





## 10. Charger indicator

Indicator status		Explanations and actions
Red LED	Green LED	
Off	Flashing	<b>Ready for use</b> The charger is connected to the mains and is ready for use; there is no battery pack in the charger
On	Off	<b>Charging</b> The charger is charging the battery pack in quick charge mode. The charging times are shown directly on the charger. <b>Important!</b> The actual charging times may vary slightly from the stated charging times depending on the existing battery charge.
Off	On	<b>The battery is charged and ready for use. (READY TO GO)</b> The unit then changes over to gentle charging mode until the battery is fully charged. To do this, leave the rechargeable battery on the charger for approx. 15 minutes longer. <b>Action:</b> Take the battery pack out of the charger. Disconnect the charger from the mains supply.
Flashing	Off	<b>Adapted charging</b> The charger is in gentle charging mode. For safety reasons the charging is performed less quickly and takes more time. The reasons can be: - The rechargeable battery has not been used for a very long time. - The battery temperature is outside the ideal range. <b>Action:</b> Wait for the charging to be completed; you can still continue to charge the battery pack.
Flashing	Flashing	<b>Fault</b> Charging is no longer possible. The battery pack is defective. <b>Action:</b> Never charge a defective battery pack. Take the battery pack out of the charger.
On	On	<b>Temperature fault</b> The battery pack is too hot (e.g. due to direct sunshine) or too cold (below 0° C). <b>Action:</b> Remove the battery pack and keep it at room temperature (approx. 20° C) for one day .

## 11. Troubleshooting guide

Faults	Possible cause	Remedy
Pump fails to prime	The intake line has a leak or is damaged	Check the following points for leaks: <ul style="list-style-type: none"> <li>- Intake line</li> <li>- Water filling screw / water drain screw / ventilation screw / coarse filter cap</li> <li>- Connection points of the intake line</li> </ul>
	Priming takes a very long time	<ul style="list-style-type: none"> <li>- Check the intake height</li> <li>- Priming can take up to 5 minutes</li> <li>- Always position the intake line so that it rises / is horizontal</li> </ul>
	Clogging in the intake line	Check and clean the following points: <ul style="list-style-type: none"> <li>- Intake line</li> <li>- Priming area</li> <li>- Intake cage (incl. non-return valve)</li> <li>- Coarse filter (incl. non-return valve)</li> </ul> Fit the following to protect the pump: <ul style="list-style-type: none"> <li>- Intake cage</li> <li>- Coarse filter</li> </ul>
	Pump housing with no pumped medium.	Fill the pump housing with pumped medium.
	Intake cage not in water.	Dip the intake cage into water. Make sure that the immersion depth / quantity of water is sufficient for the level not to drop below the intake cage when water is drawn off.
	Air cannot escape	<ul style="list-style-type: none"> <li>- Open the corresponding shut-off devices (spray nozzles, valves etc.) in the discharge line. Begin with the shut-off devices closest to the pump.</li> <li>- When the pump is being filled, open the ventilation screw so that air can escape from the pump housing.</li> </ul>

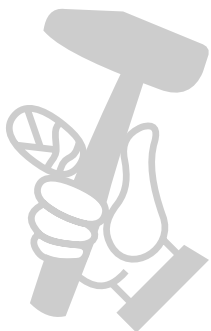

Faults	Possible cause	Remedy
Insufficient pumping rate	The intake line has a leak or is damaged	Check the following points for leaks: - Intake line - Water filling screw / water drain screw / ventilation screw / coarse filter cap - Connection points of the intake line
	Intake height too high.	Check the intake height.
	The intake cage (incl. the non-return valve) is soiled.	Clean the intake cage (incl. the non-return valve).
	The coarse filter (incl. the non-return valve) is soiled.	Clean the coarse filter (incl. the non-return valve).
	The hose on the discharge side is kinked.	Remove any kinks in the hose.
	The cross-section on the discharge side becomes narrower.	Avoid narrow points.
	The pump's delivery rate depends on the delivery head and on the connected peripherals.	Take account of the maximum delivery head, change the hose diameter or hose length if necessary.
	The battery is not correctly inserted.	Remove the battery and insert it again.
	The battery is empty.	Check the battery charge level and charge the battery if necessary.
The motor does not start	The battery charge level is low.	Check the battery charge level and charge the battery if necessary.
	The impeller is blocked.	Use a screwdriver to turn the motor shaft through the fan hood (release the stuck mechanical seal).
The thermostat switches off the pump	Overheating / overloading of the pump	Let the equipment cool down!
	The temperature of the pumped medium or the environment is too high.	Take account of the permitted temperature of the pumped medium. Ensure that the pump is provided with adequate cooling.
	Dry-running of the pump.	Eliminate the cause of the dry-running. Note the points under "Pump fails to prime". Prevent dry-running.



For EU countries only

Never place any electric power tools in your household refuse.

To comply with European Directive 2012/19/EC concerning old electric and electronic equipment and its implementation in national laws, old electric power tools have to be separated from other waste and disposed of in an environment-friendly fashion, e.g. by taking to a recycling depot.

Recycling alternative to the return request:

As an alternative to returning the equipment to the manufacturer, the owner of the electrical equipment must make sure that the equipment is properly disposed of if he no longer wants to keep the equipment. The old equipment can be returned to a suitable collection point that will dispose of the equipment in accordance with the national recycling and waste disposal regulations. This does not apply to any accessories or aids without electrical components supplied with the old equipment.

Please note that batteries and lamps (e.g. light bulbs) must be removed from the tool before it is disposed of.

The reprinting or reproduction by any other means, in whole or in part, of documentation and papers accompanying products is permitted only with the express consent of the Einhell Germany AG.

Subject to technical changes

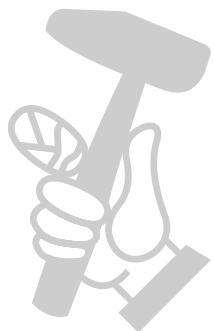

## Service information

We have competent service partners in all countries named on the guarantee certificate whose contact details can also be found on the guarantee certificate. These partners will help you with all service requests such as repairs, spare and wearing part orders or the purchase of consumables.

Please note that the following parts of this product are subject to normal or natural wear and that the following parts are therefore also required for use as consumables.

Category	Example
Wear parts*	Carbon brushes, coarse filter/filter cartridge, rechargeable battery
Consumables*	
Missing parts	

\* Not necessarily included in the scope of delivery!

In the event of defects or faults, please register the problem on the internet at [www.Einhell-Service.com](http://www.Einhell-Service.com). Please ensure that you provide a precise description of the problem and answer the following questions in all cases:

- Did the equipment work at all or was it defective from the beginning?
- Did you notice anything (symptom or defect) prior to the failure?
- What malfunction does the equipment have in your opinion (main symptom)? Describe this malfunction.

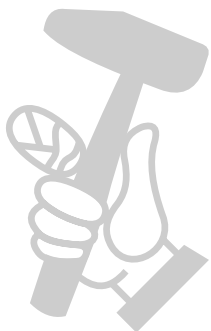

## Warranty certificate

Dear Customer,

All of our products undergo strict quality checks to ensure that they reach you in perfect condition. In the unlikely event that your device develops a fault, please contact our service department at the address shown on this guarantee card. You can also contact us by telephone using the service number shown.

Please note the following terms under which guarantee claims can be made:

1. These guarantee terms apply to consumers only, i.e. natural persons intending to use this product neither for their commercial activities nor for any other self-employed activities. These warranty terms regulate additional warranty services, which the manufacturer mentioned below promises to buyers of its new products in addition to their statutory rights of guarantee. Your statutory guarantee claims are not affected by this guarantee. Our guarantee is free of charge to you.
2. The warranty services cover only defects due to material or manufacturing faults on a product which you have bought from the manufacturer mentioned below and are limited to either the rectification of said defects on the product or the replacement of the product, whichever we prefer.  
Please note that our devices are not designed for use in commercial, trade or professional applications. A guarantee contract will not be created if the device has been used by commercial, trade or industrial business or has been exposed to similar stresses during the guarantee period.
3. The following are not covered by our guarantee:
  - Damage to the device caused by a failure to follow the assembly instructions or due to incorrect installation, a failure to follow the operating instructions (for example connecting it to an incorrect mains voltage or current type) or a failure to follow the maintenance and safety instructions or by exposing the device to abnormal environmental conditions or by lack of care and maintenance.
  - Damage to the device caused by abuse or incorrect use (for example overloading the device or the use of unapproved tools or accessories), ingress of foreign bodies into the device (such as sand, stones or dust, transport damage), the use of force or damage caused by external forces (for example by dropping it).
  - Damage to the device or parts of the device caused by normal or natural wear or tear or by normal use of the device.
4. The guarantee is valid for a period of 24 months starting from the purchase date of the device. Guarantee claims should be submitted before the end of the guarantee period within two weeks of the defect being noticed. No guarantee claims will be accepted after the end of the guarantee period. The original guarantee period remains applicable to the device even if repairs are carried out or parts are replaced. In such cases, the work performed or parts fitted will not result in an extension of the guarantee period, and no new guarantee will become active for the work performed or parts fitted. This also applies if an on-site service is used.
5. To make a claim under the guarantee, please register the defective device at: [www.Einhell-Service.com](http://www.Einhell-Service.com). Please keep your bill of purchase or other proof of purchase for the new device. Devices that are returned without proof of purchase or without a rating plate shall not be covered by the guarantee, because appropriate identification will not be possible. If the defect is covered by our guarantee, then the item in question will either be repaired immediately and returned to you or we will send you a new replacement.

Of course, we are also happy offer a chargeable repair service for any defects which are not covered by the scope of this guarantee or for units which are no longer covered. To take advantage of this service, please send the device to our service address.

Also refer to the restrictions of this warranty concerning wear parts, consumables and missing parts as set out in the service information in these operating instructions.

