

metabo®

PROFESSIONAL POWER TOOL SOLUTIONS

HS 18 LTX 45
HS 18 LTX 55
HS 18 LTX 65



de	Originalbetriebsanleitung 4	no	Original bruksanvisning 40
en	Original instructions 8	da	Original bruksanvisning 44
fr	Notice originale 12	pl	Instrukcja oryginalna 48
nl	Oorspronkelijke gebruiksaanwijzing 16	el	Πρωτότυπο οδηγών χρήσης 52
it	Istruzioni originali 20	hu	Eredeti használati utasítás 56
es	Manual original 24	ru	Оригинальное руководство по эксплуатации 60
pt	Manual original 28	uk	Переклад оригінальної інструкції з експлуатації 65
sv	Bruksanvisning i original 32		
fi	Alkuperäiset ohjeet 36		

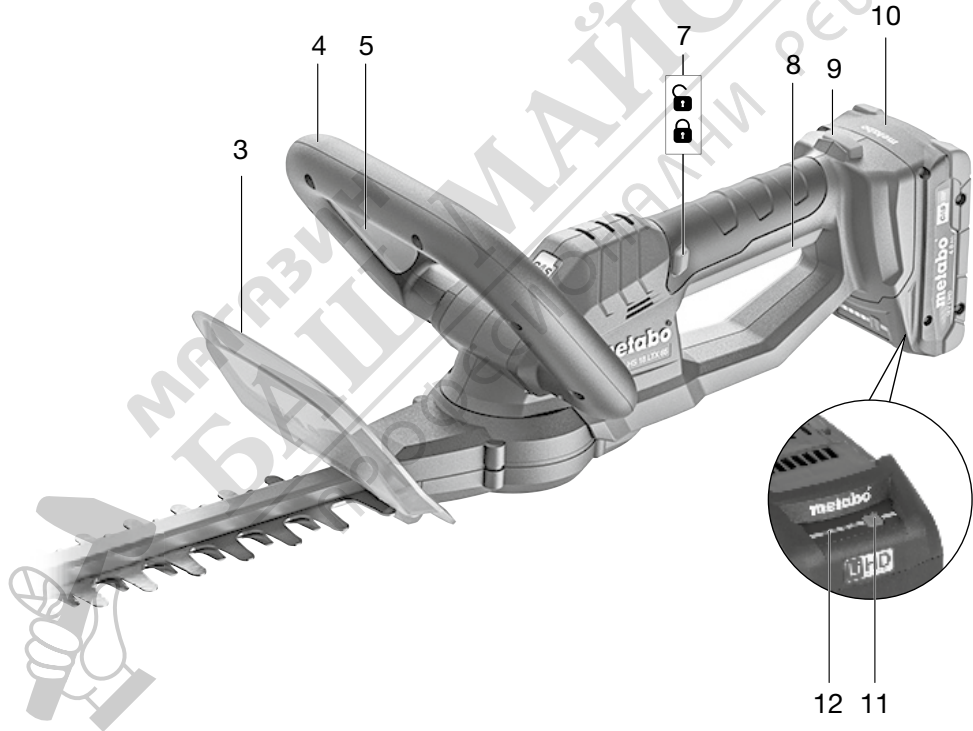

		HS 18 LTX 45	HS 18 LTX 55	HS 18 LTX 65
*1) Serial Number		01717..	01718..	01719..
U	V	18	18	18
ø max.	mm (in)	19 (³ / ₄)	19 (³ / ₄)	19 (³ / ₄)
L	cm (in)	43 (17)	53 (21)	63 (25)
n₀	/min	2600	2600	2600
m	kg (lbs)	2,5 (5.5)	2,7 (5.1)	2,9 (6.4)
a_h/K_h	m/s²	2,5 / 1,5		
L_{pA}/K_{pA}	dB(A)	78 / 3	77 / 3	78 / 3
L_{WA}/K_{WA}	dB(A)	86,9 / 6,1	89,2 / 2,6	89,1 / 0,5
L_{WA(G)}	dB(A)	93		



*2) 2014/30/EU, 2006/42/EC, 2000/14/EC, 2011/65/EU

*3) EN 60745-1:2009+A11:2010, EN 60745-2-15:2009+A1:2010, EN IEC 63000:2018

2021-07-09, Bernd Fleischmann
 Direktor Produktentstehung & Qualität (Vice President Product Engineering & Quality)
 *4) Metabowerke GmbH - Metabo-Allee 1 - 72622 Nuertingen, Germany

ppa. B.F.

Original instructions

1. Declaration of Conformity

We declare and accept sole responsibility for ensuring: these cordless hedge trimmers identified by their type and serial number *1) conform to all relevant provisions of the directives *2) and standards *3). Technical documents for *4) - see page 3.

2000/14/EC: Conformity assessment procedures in accordance with Annex V.

For UK only:

UK We as manufacturer and authorized person to **CA** compile the technical file, see *4) on page 3, hereby declare under sole responsibility that these cordless hedge trimmers, identified by type and serial number *1) on page 3, fulfill all relevant provisions of following UK Regulations *2) S.I. 2016/1091, S.I. 2008/1597, S.I. 2001/1701, S.I. 2012/3032 and Designated Standards EN 62841-1:2015, EN 62841-4-2:2020, EN ISO 63000:2018 S.I. 2001/1701: Conformity assessment procedures in accordance with schedule 8

2. Specified Conditions of Use

The cordless hedge trimmer is suitable for cutting hedges and bushes.

The user bears sole responsibility for any damage caused by inappropriate use.

Generally accepted accident prevention regulations and the enclosed safety information must be observed.

3. General Safety Information



For your own protection and for the protection of your power tool, pay attention to all parts of the text that are marked with this symbol!



WARNING – Read the operating instructions to reduce the risk of injury.



WARNING Read all safety warnings and instructions. Failure to follow all safety warnings and instructions may result in electric shock, fire and/or serious injury.

Keep all safety instructions and information for future reference.

Pass on your power tool only together with these documents.

4. Special Safety Instructions

a) Keep body parts well away from the blade. Never attempt to remove cuttings with the blade running, or to hold on to material to be cut. The blades continue to run after operating the switch. A moment of inattentiveness when using the hedge trimmer can result in serious injuries.

b) Carry the hedge trimmer from the handle when the blade is at a standstill and makes sure not to operate the switch. Proper carrying of the hedge trimmer reduces the risk of unintentional operation and any subsequent injury caused by the blade.

c) When transporting or storing the hedge trimmer, always pull the cover over the blades. Careful handling of the hedge trimmer reduces the risk of injury from the blade.

d) Ensure that all switches are off and the battery pack is disconnected before removing jammed material or servicing the machine. Unexpected operation of the hedge trimmer when removing jammed material may lead to serious personal injury.

e) Make sure you only hold the hedge trimmers by the isolated handle grips: the cutting blade could strike hidden power lines. Blades contacting a "live" wire may make exposed metal parts of the power tool "live" and could give the operator an electric shock.

f) Always keep any power lines away from the cutting range. Lines could be hidden in hedges and bushes and the blade could unintentionally cut them.

g) Do not operate the hedge trimmer in bad weather conditions, especially when there is a risk of lightning. This reduces the risk to be hit by lightning.

Inspect hedges and bushes for wire fences and concealed lines.

Persons under the age of 16 must not use the hedge trimmer.

Never use an incomplete tool, or one on which an unauthorised modification has been made.

Do not switch on the tool if parts or guard devices are missing or defective.

The machine features safety two-hand operation. Have the machine repaired if it can be activated with only one switch.

The machine is provided with a "Quick stop" function. Have the machine repaired if braking time is clearly lengthened.

Wear ear protectors. Exposure to noise can cause hearing loss.

Danger of injury from the sharp edges of the blades. Never touch the blades. Wear protective gloves.

Always wear protective goggles, gloves, and suitable shoes when working with the hedge trimmer.

Always hold the machine with both hands and stand firmly on the ground. The hedge trimmer is intended for work where the operator stands on the ground and not on a ladder or any other unstable floor space. Pay attention to obstacles in the working area - danger of tripping. Keep the cutting blade well away from the body.

Examine the area to be cut and remove wire or other foreign bodies.

If the cutting blades come to a standstill due to a particularly hard branch or foreign body (wire in a hedge) and the stoppage cannot be corrected by pulling the machine back, the motor must first be switched off and the battery pack removed from the machine before the cause of the blockage can be removed manually from the cutting blade.

For other activities (e.g. removing twigs or cuttings), deposit the machine outside the working area.

Lay the machine down such that persons are not at risk.

Remove the battery pack from the machine when not in use.

For storage and transportation, always slide the enclosure onto the cutting blades. (It has been slid on correctly if the Metabo lettering faces upwards).

Only carry the machine by the bow-type handle.

Safety instructions for battery packs:

 Protect battery packs from water and moisture!

 Do not expose battery packs to fire!

Do not use faulty or deformed battery packs!
Do not open battery packs!
Do not touch or short circuit battery pack contacts!

 A slightly acidic, flammable fluid may leak from defective Li-ion battery packs!

 If battery fluid leaks out and comes into contact with your skin, rinse immediately with plenty of water. If battery fluid leaks out and comes into contact with your eyes, wash them with clean water and seek medical attention immediately!

Remove the battery pack from the machine before making any adjustments, changing tools, maintaining or cleaning.

Make sure that the tool is switched off before fitting the battery pack.

Hold the machine when removing and inserting the battery pack so that the on/off switch cannot be unintentionally pressed.

If the machine is defective, remove the battery pack from the machine.

Transport of li-ion battery packs:

The shipping of li-ion battery packs is subject to laws related to the carriage of hazardous goods (UN 3480 and UN 3481). Inform yourself of the currently valid specifications when shipping li-ion battery packs. If necessary, consult your freight forwarder. Certified packaging is available from Metabo.

Only send the battery pack if the housing is intact and no fluid is leaking. Remove the battery pack from the machine for sending. Prevent the contacts from short-circuiting (e.g. by protecting them with adhesive tape).

 **WARNING** - General hazards

 Read the operating instructions.

 Protect the device from water and moisture. Do not expose to rain. Never use in rain or on wet hedges.

 Wear safety goggles.

 Wear ear protectors. High noise levels over a prolonged period of time may affect your hearing.

 Keep hands away from the blade.

5. Overview

See page 2.

- 1 Protective sheath for blade
- 2 Impact protection with twig feed
- 3 Hand protection
- 4 Bow-type handle
- 5 Frame switch (safety two-hand operation)
- 6 Blades
- 7 Switch-on lock: To lock the trigger (8) to prevent the tool from being switched on inadvertently.
- 8 Switch (safety two-hand operation)
- 9 Battery pack release button
- 10 Battery pack
- 11 Capacity indicator button
- 12 Capacity and signal indicator

6. Initial Operation

6.1 Battery pack

Charge the battery pack before use.
Recharge the battery pack if performance diminishes.

Instructions on charging the battery pack can be found in the operating instructions of the Metabo charger.

In case of Li-Ion battery packs with capacity and signal display (12) (equipment-specific):

- Press the button (11), the LEDs indicate the charge level.
- The battery pack is almost flat and must be recharged if one LED is flashing.

6.2 Removing and inserting the battery pack

 Hold the machine when removing and inserting the battery pack so that the on/off switch cannot be unintentionally pressed.

Removing:

Press the battery pack release (9) button and remove the battery pack (10).

Inserting:



Slide in the battery pack (10) until it engages.

Check quick stop:
Switch machine on briefly and then off again.
Have the machine repaired if braking time is clearly lengthened.

7. Use

7.1 Switch-on lock, switching on and off (safety two-hand operation):

The switch-on lock (7) must be released to switch on the machine.

-  Switch (8) locked
-  Switch (8) unlocked.

- Switching on: Press the switch (8), press the frame switch (5).
- Switching off: Release switch (5) or (8). As long as the switch (8) is pressed, the switch-on lock (7) is not engaged.

Thanks to the Quick stop, the cutting blades come to a standstill within 0.08 seconds.

 Have the machine repaired if braking time is clearly lengthened.

7.2 Cleaning the cutting blade (after each use)

 **Before cleaning:**
Switch off the machine. Remove battery pack (10) from the machine.

 Wear protective gloves.

Remove contamination, leaf debris etc. (e.g. with a brush or cloth)

After cleaning: Treat cutting blade with Metabo hedge trimmer care oil 6.30474 or Pump Spray 6.30475 (biologically degradable).

8. Maintenance

It is advisable to have blunt cutting blades sharpened in a specialist workshop. Check cutting blades regularly for damage and have them repaired in a specialist workshop immediately if necessary.

9. Accessories

Use only original Metabo or CAS (Cordless Alliance System) battery packs and accessories.

- A Chargers: ASC 55, ASC 145, etc.
Order no.: 627044000ASC 55
Order no.: 627378000ASC 145
etc.
- B Battery packs:
Order no.: 625367000 4.0 Ah (LiHD)
Order no.: 625368000 5.5 Ah (LiHD)
Order no.: 625369000 8.0 Ah (LiHD)

Order no.: 625026000 2.0 Ah (Li-Power)
Order no.: 625027000 4.0 Ah (Li-Power)

Order no.: 625028000 5.2 Ah (Li-Power) etc.

- C Hedge trimmer care oil (biologically degradable), can (1 litre)
Order no.: 630475000
- D Hedge trimmer care oil (biologically degradable), Pump Spray can (0.3 litre)
Order no.: 630474000

For a complete range of accessories, see www.metabo.com or the catalogue.

10. Repairs

 Repairs to electrical tools must ONLY be carried out by qualified electricians!

Contact your local Metabo representative if you have Metabo power tools requiring repairs. For addresses see www.metabo.com.

You can download a list of spare parts from www.metabo.com.

11. Environmental Protection

Observe national regulations on environmentally compatible disposal and on the recycling of disused machines, packaging and accessories.

Battery packs must not be disposed of with regular waste! Please return faulty or used battery packs to your Metabo dealer!

Do not throw battery packs into water.

 Only for EU countries: never dispose of power tools in your household waste!
According to European Directive 2012/19/EU on Waste from Electric and Electronic Equipment and implementation in national law, used power tools must be collected separately and recycled in an environmentally-friendly manner. Discharge the battery pack in the power tool before disposal. Prevent the contacts from short-circuiting (e.g. by protecting them with adhesive tape).

12. Technical Specifications

Explanatory notes on the specifications on page 3.
Subject to change in accordance with technical progress.

- U = Voltage of battery pack
- σ max. = maximum cutting thickness
- L = Useful blade length
- n₀ = number of cuts at idling speed
- m = Weight with smallest battery pack

Measured values determined in conformity with EN 62841.

Permitted ambient temperature during operation:
-20 °C to 50 °C (limited performance with temperatures below 0 °C). Permitted ambient temperature for storage: 0 °C to 30 °C

== direct current

The technical specifications quoted are subject to tolerances (in compliance with relevant valid standards).



Emission values

These values make it possible to assess the emissions from the power tool and to compare different power tools. The actual load may be higher or lower depending on operating conditions, the condition of the power tool or the accessories used. Please allow for breaks and periods when the load is lower for assessment purposes. Arrange protective measures for the user, such as organisational measures based on the adjusted estimates.

Vibration total value (vector sum of three directions) determined in accordance with EN 62841:

a_h = Vibration emission value (idle speed)

K_h = Uncertainty (vibration)

Typical A-effective perceived sound levels:

L_{pA} = sound-pressure level

L_{WA} = Acoustic power level

K_{pA} , K_{WA} = Uncertainty

$L_{WA(G)}$ = guaranteed acoustic power level as per 2000/14/EC



During operation the noise level can exceed 80 dB(A).



Wear ear protectors!



МАГАЗИН
БАШ МАЙСТОРА
ПРОФЕСИОНАЛНИ РЕШЕНИЯ