

Milwaukee

Nothing but **HEAVY DUTY**®



M18 FN18GS

Original instructions



МАГАЗИН
БАШ

МАЙСТРА

ПРОФЕСИОНАЛНИ

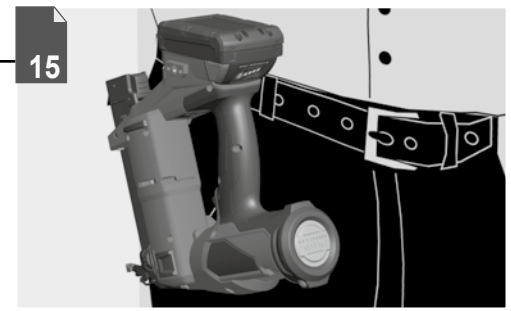
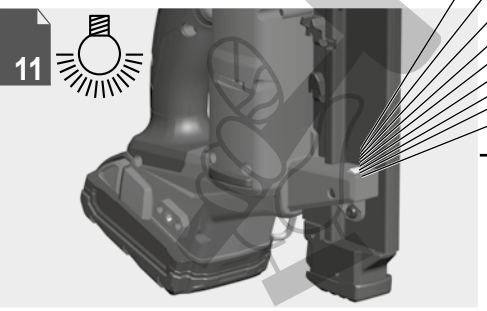
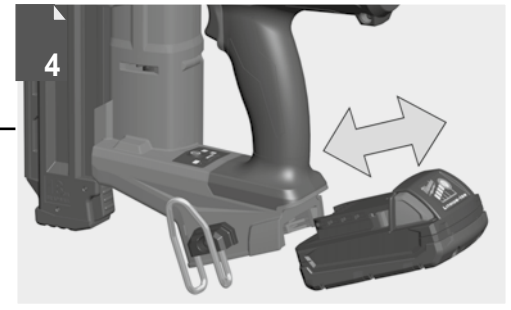
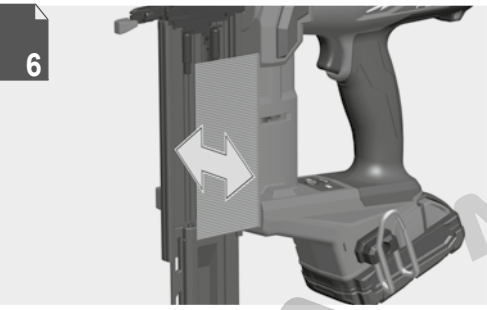
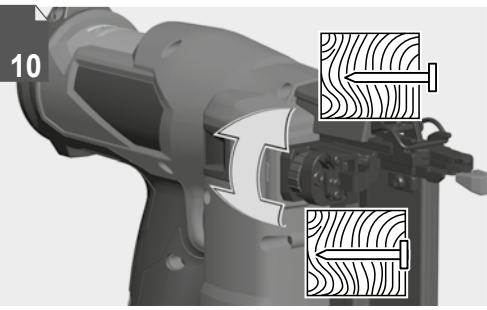
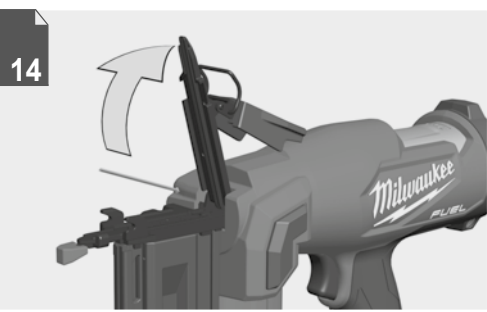

20 Text section with Technical Data, important Safety and Working Hints and description of Symbols



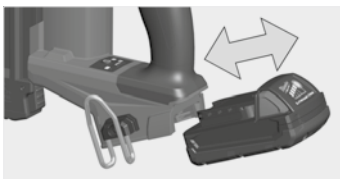

Remove the battery pack before starting any work on the machine.

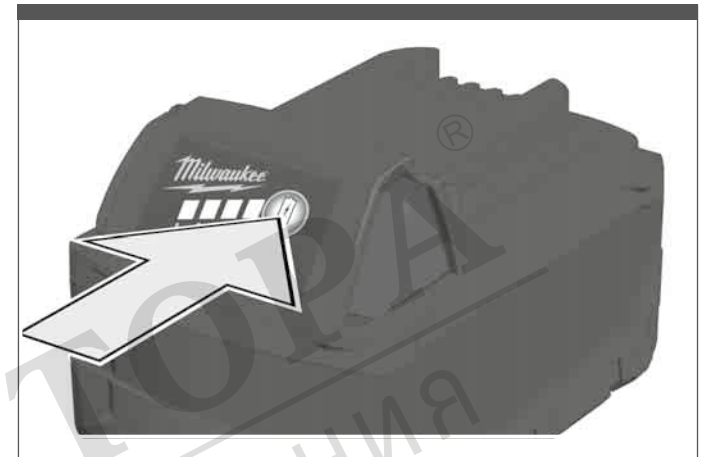
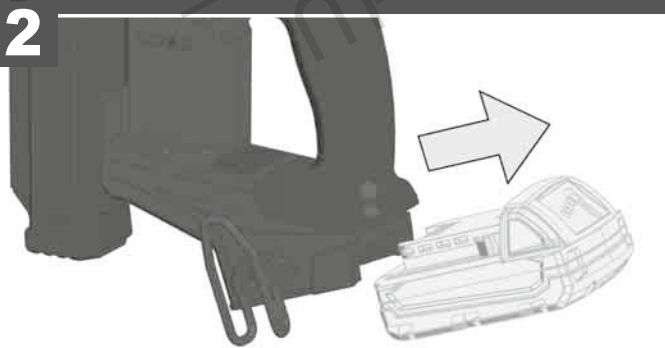
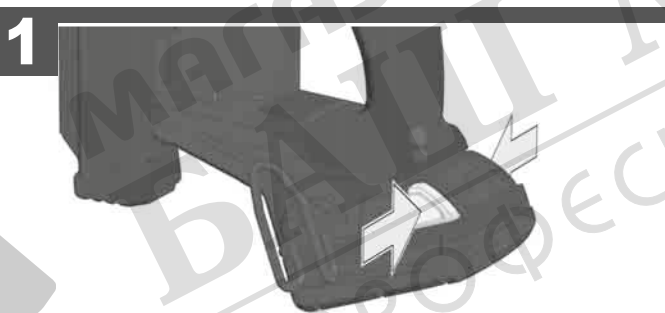
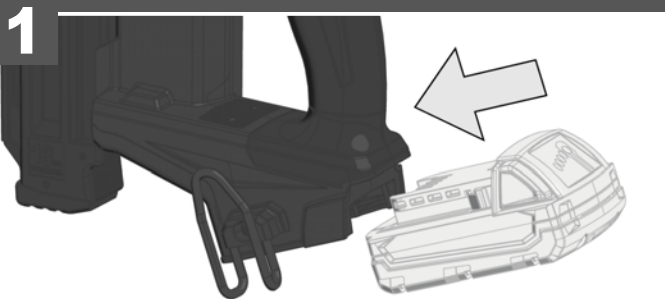

78-100 %



55-77 %



33-54 %



10-32 %



< 10 %

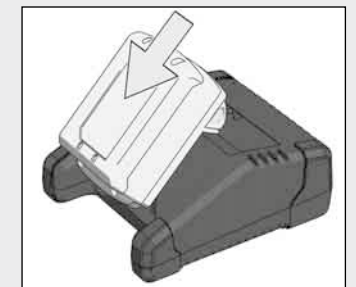
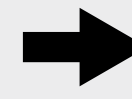

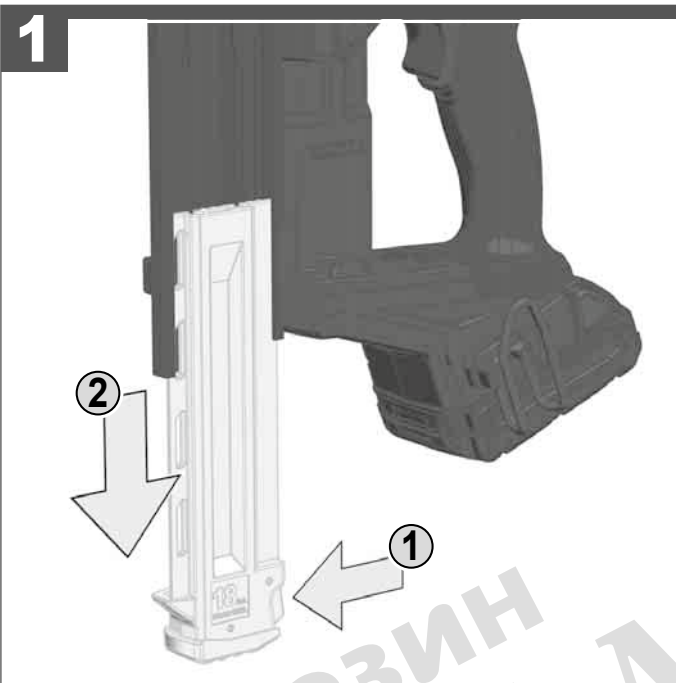

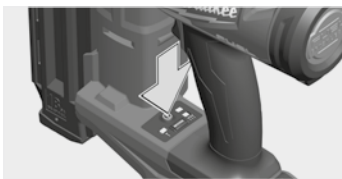

Switching on-off
Press and hold the power button for 2 seconds.

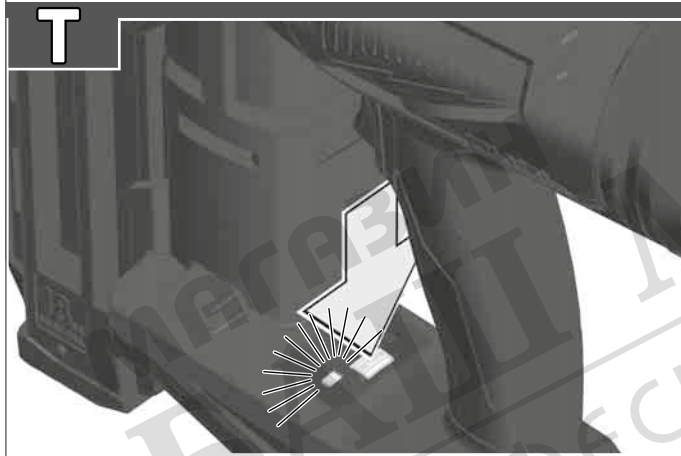
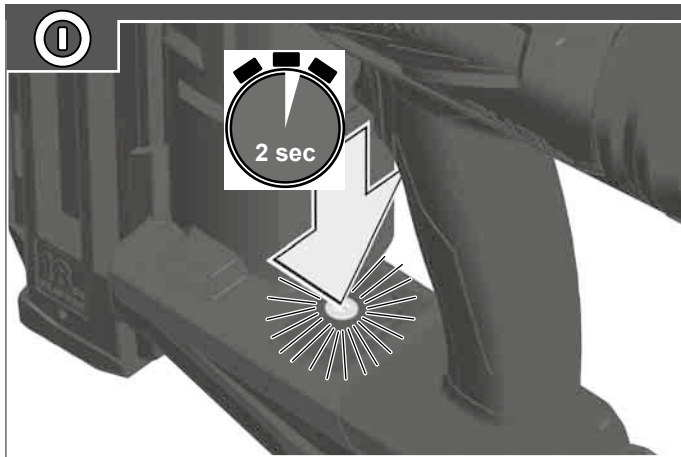

Single Sequential Actuation

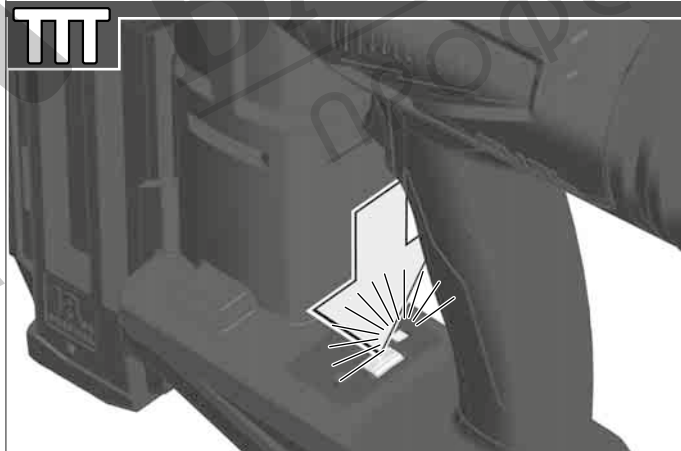

Contact (Bump) Actuation

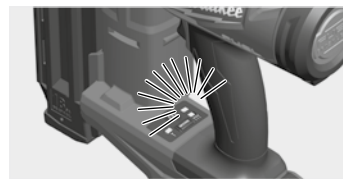

Low Battery LED
If the red light will on, the battery is low. The tool will not be able to fire nails. To continue work, charge the battery.

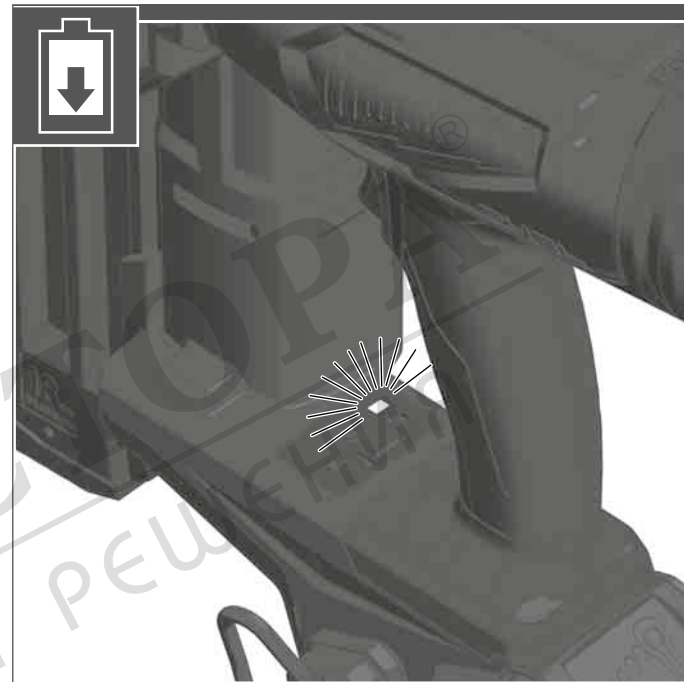

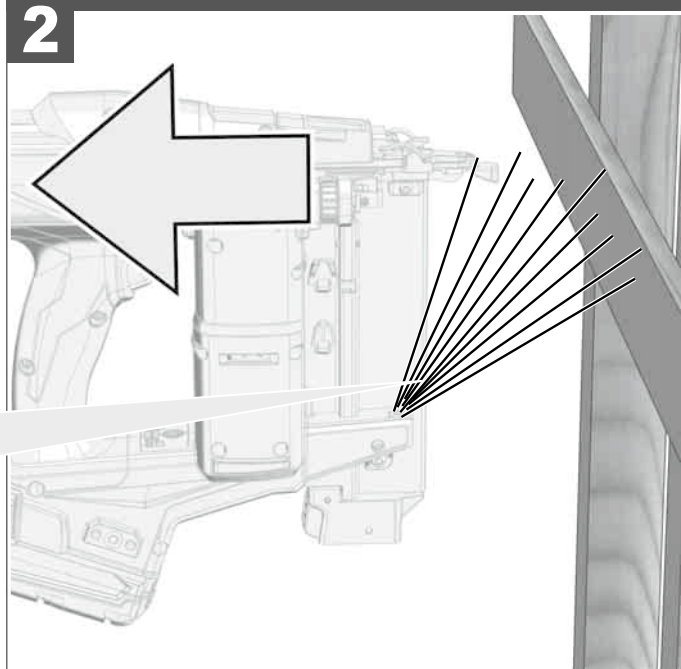
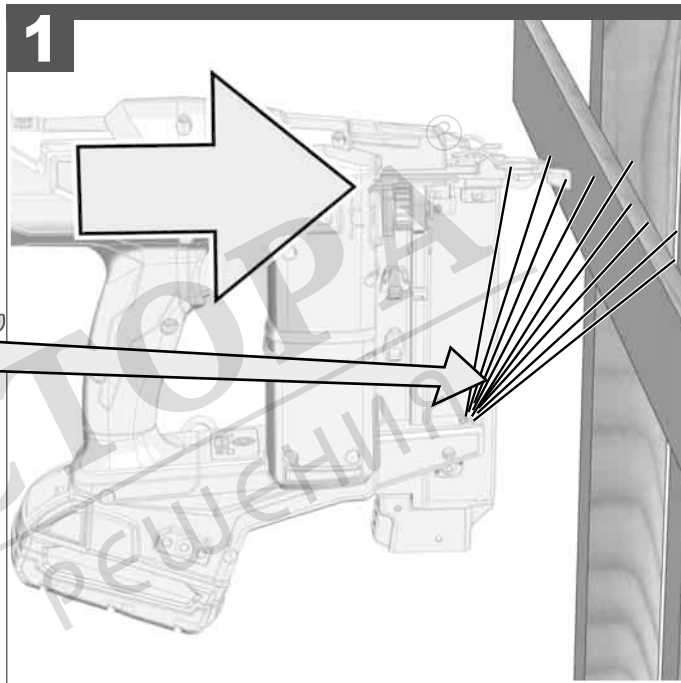
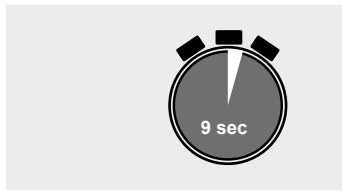
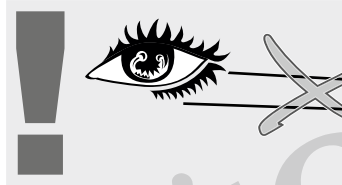
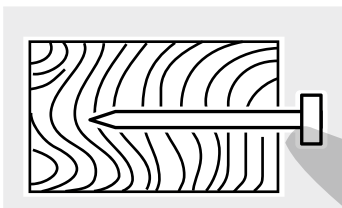
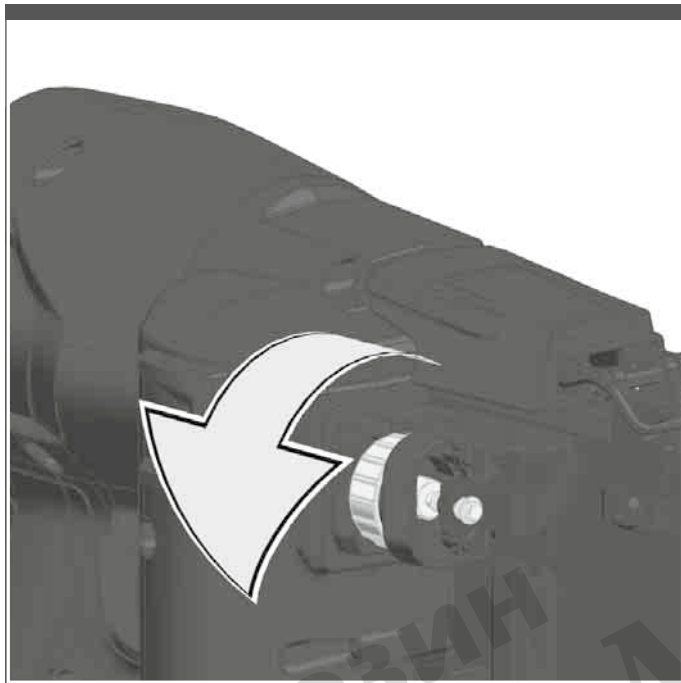
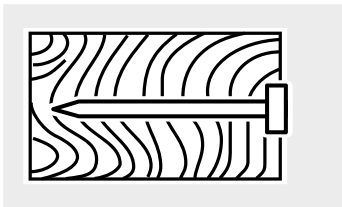



Single Sequential Actuation

Switch to single sequential actuation:
Press MODE Button - LED **T** will light.

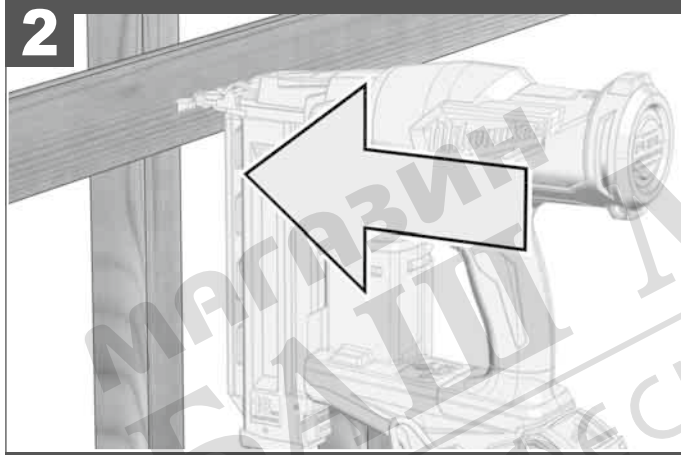
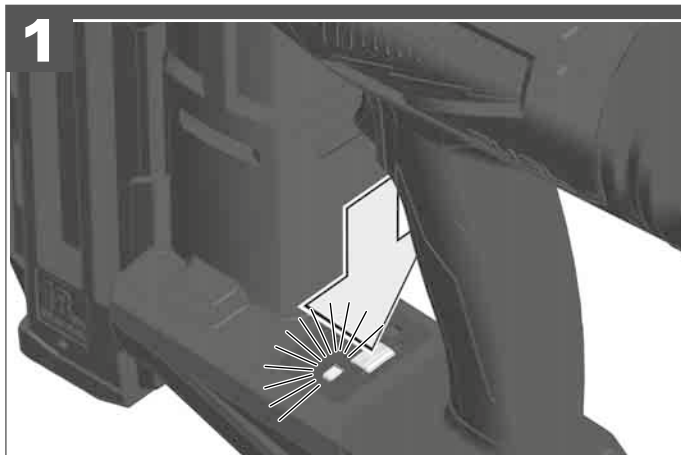

Push the tool against the work surface,
compressing the workpiece contact.

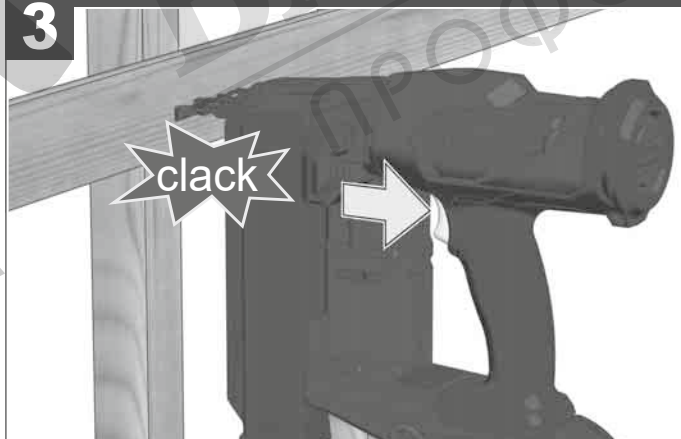

Pull the trigger to drive the fastener.



Contact (Bump) Actuation

Switch to Contact Actuation:
Press MODE Button - LED **TTT** will light.



Pull and hold the trigger

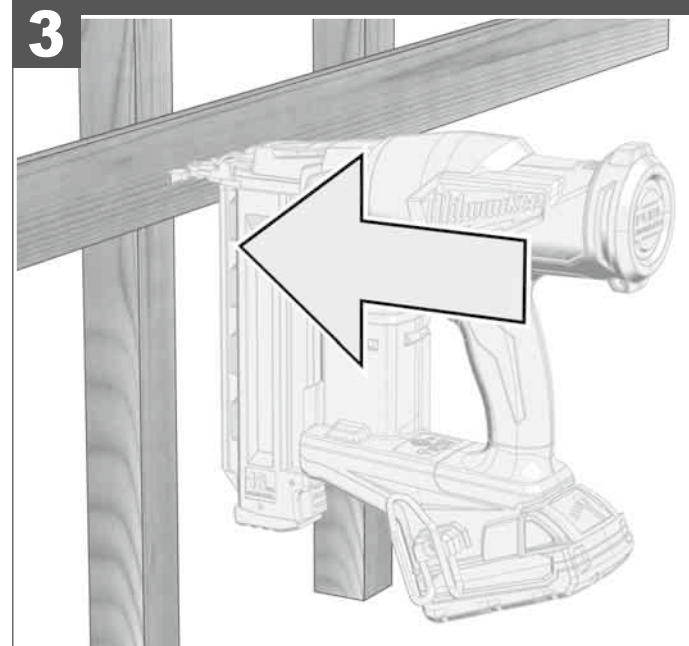

Push the tool against the work surface,
compressing the workpiece contact to drive
the fastener.

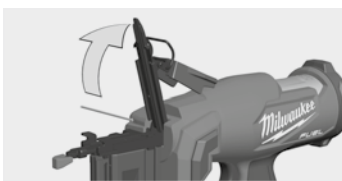

Clearing a jammed Fastener

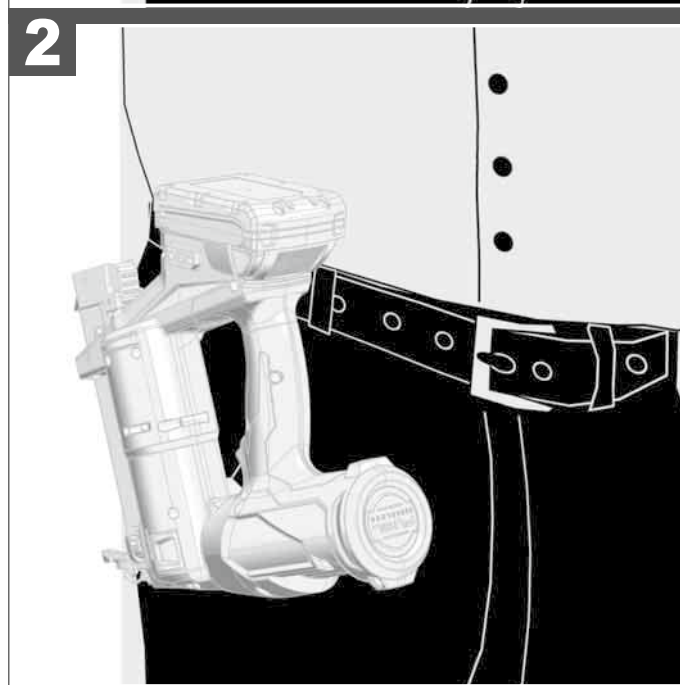
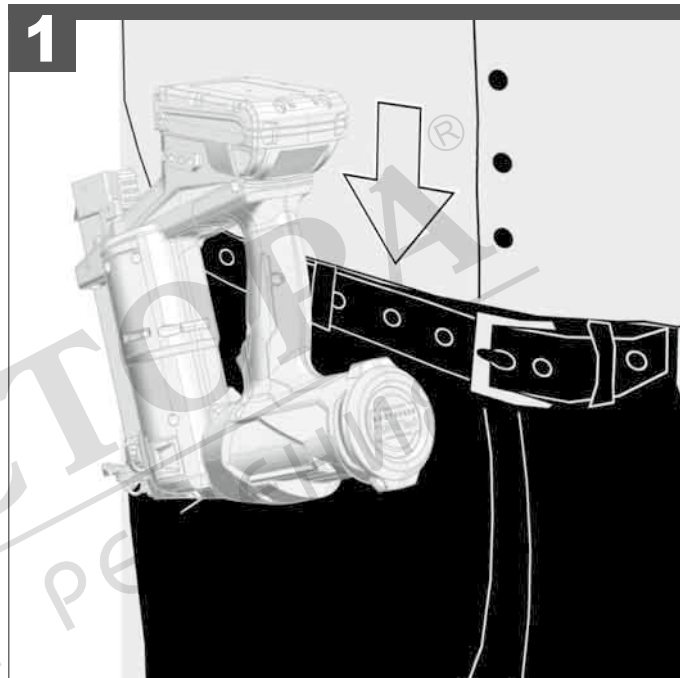
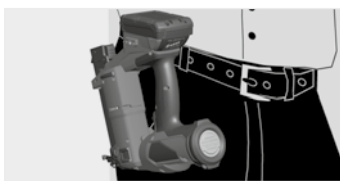
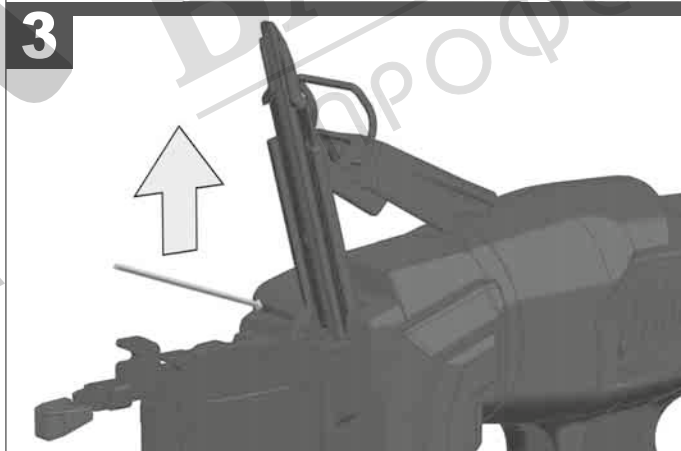
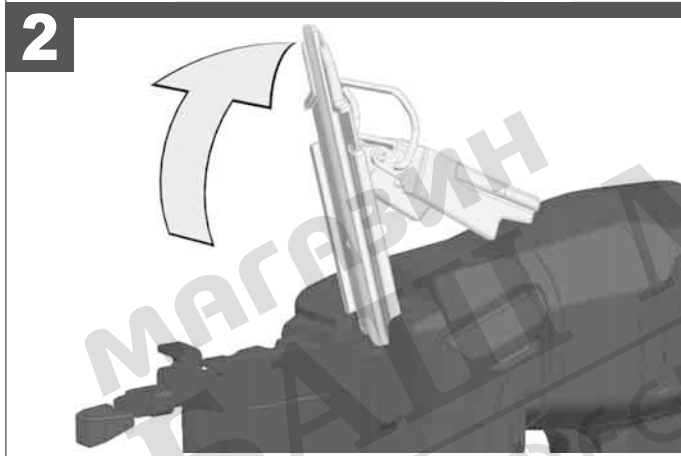
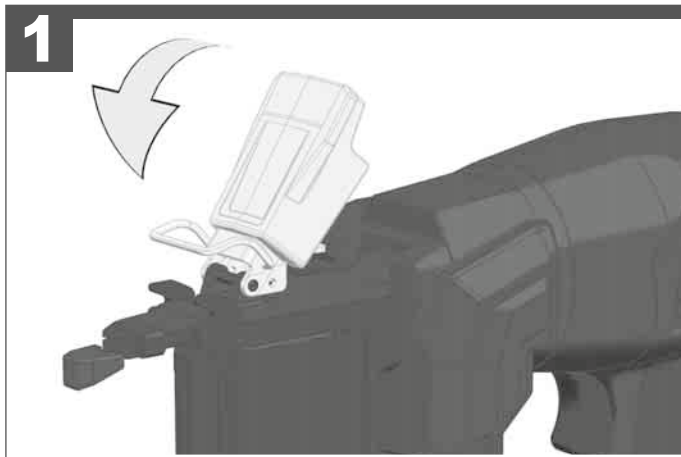

TECHNICAL DATA CORDLESS NAILER M18 FN18GS

Production code.....	4741 26 02
	...000001-999999
Collation angle.....	0°
Fastener type: brad	
Diameter.....	1,2 mm
Length min./max.....	16/54 mm
Magazine capacity (number of nails).....	110
Cycle rate.....	900 /h
Battery voltage.....	18 V
Weight according EPTA-Procedure 01/2014 (2.0 Ah ... 12.0 Ah).....	2,9 kg ... 4,0 kg
Recommended ambient operating temperature.....	-18°C ... +50 °C
Recommended battery types.....	M18B...M18HB...
Recommended charger.....	M12-18 C...M1418 C6

Noise/vibration information

Measured values determined according to EN 60 745.

Typically, the A-weighted noise levels of the tool are:

Sound pressure level (Uncertainty K=3dB(A)).....	81,1 dB (A)
Sound power level (Uncertainty K=3dB(A)).....	92,1 dB (A)

Wear ear protectors!

Total vibration values (vector sum in the three axes) determined according to EN 60 745.

Vibration emission value a _w	1,97 m/s ²
Uncertainty K=.....	1,5 m/s ²

WARNING

The vibration and noise emission level given in this information sheet has been measured in accordance with a standardized test given in EN 60745 and may be used to compare one tool with another. It may be used for a preliminary assessment of exposure.

The declared vibration and noise emission level represents the main applications of the tool. However if the tool is used for different applications, with different accessories or poorly maintained, the vibration and noise emission may differ. This may significantly increase the exposure level over the total working period.

An estimation of the level of exposure to vibration and noise should also take into account the times when the tool is switched off or when it is running but not actually doing the job. This may significantly reduce the exposure level over the total working period.

Identify additional safety measures to protect the operator from the effects of vibration and noise such as: maintain the tool and the accessories, keep the hands warm, organization of work patterns.

⚠ WARNING Read all safety warnings, instructions, illustrations and specifications provided with this power tool. Failure to follow all instructions listed below may result in electric shock, fire and/or serious injury.

Save all warnings and instructions for future reference.

⚠ CORDLESS NAILER SAFETY WARNINGS

Always assume that the tool contains fasteners. Careless handling of the nailer can result in unexpected firing of fasteners and personal injury.

Do not point the tool towards yourself or anyone nearby. Unexpected triggering will discharge the fastener causing an injury.

Do not actuate the tool unless the tool is placed firmly against the workpiece. If the tool is not in contact with the workpiece, the fastener may be deflected away from your target.

Disconnect the tool from the power source when the fastener jams in the tool. While removing a jammed fastener, the nailer may be accidentally activated if it is plugged in.

Use caution while removing a jammed fastener. The mechanism may be under compression and the fastener may be forcefully discharged while attempting to free a jammed condition.

Do not use this nailer for fastening electrical cables. It is not designed for electric cable installation and may damage the insulation of electric cables thereby causing electric shock or fire hazards.

Wear ear protectors. Exposure to noise can cause hearing loss.

Hold power tool by insulated gripping surfaces, when performing an operation where the nail may contact hidden wiring. Nails contacting a "live" wire may make exposed metal parts of the power tool "live" and could give the operator an electric shock.

Always wear eye protection with side shields. Everyday glasses have only impact resistant lenses. They are not safety glasses. Following this rule will reduce the risk of serious personal injury.

Eye protection provides protection against flying particles both from the FRONT and SIDE should ALWAYS be worn by the operator and others in the work area when loading, operating or servicing this tool. Eye protection is required to guard against flying fasteners and debris, which could cause severe eye injury.

Always remove the battery before adjusting the depth of drive wheel. Do not pull back on the adjustment wheel, the wheel is designed to be rotated.

Do not press the trigger while adjusting the depth of drive wheel. Always select full sequential firing mode before adjusting the depth of drive.

Do not point the tool towards yourself or anyone nearby when adjusting the depth of drive.

ADDITIONAL SAFETY INSTRUCTIONS

Always be aware that misuse and improper handling of this tool can cause injury to yourself and others.

The tool is designed for single-hand use. Do not hold the tool by the front of the magazine. Do not put hands, head, or other parts of your body near the bottom of the magazine where the nail exits the tool, as serious personal injury could be caused.

Always ensure that the workpiece contact is fully positioned above the workpiece. Positioning the workpiece contact only partially above the workpiece could cause the nail to miss the workpiece completely and result in serious personal injury.

Do not drive nails near edge of material. The workpiece may split causing the nail to ricochet, injuring you or a coworker. Be aware that the nail may follow the grain of the wood, causing it to protrude unexpectedly from the side of the work material or deflect, possibly causing injury.

Keep hands and body parts clear of immediate work area. Hold workpiece with clamps when necessary to keep hands and body out of potential harm. Be sure the workpiece is properly secured before pressing the fastener against the material. The workpiece contact may cause the work material to shift unexpectedly. Keep face and body

parts away from back of the tool cap when working in restricted areas. Sudden recoil can result in impact to the body, especially when nailing into hard or dense material.

During normal use the tool will recoil immediately after driving a fastener. This is a normal function of the tool. Do not attempt to prevent the recoil by holding the nailer against the work. Restriction to the recoil can result in a second fastener being driven from the nailer. Grip the handle firmly, let the tool do the work and do not place second hand on top of tool or near exhaust at any time. Failure to heed this warning can result in serious personal injury.

Do not drive fasteners on top of other fasteners or with the tool at an overly steep angle as this may cause deflection of fasteners which could cause injury.

Always check the work area for hidden wiring, gas lines, water lines, etc., before using the product on such work area.

After using the product in the contact actuation mode, switch it back to the full sequential mode.

The driving depth of the nail may be adjusted beyond air pressure. It is advisable to test the depth on a scrap workpiece to determine the required depth for the application.

Only fasteners matching the description in the Technical Data can be used with this tool. Using incorrect fasteners may lead to jamming or other malfunctions.

Do not select contact actuation mode when working on scaffolds, ladders or platforms where you may need to move your body position. You may unintentionally fire a nail by inadvertent activation of the workpiece contact while moving about if the contact actuation mode is selected. When moving positions, select full sequential activation or deactivate the product completely by removing the battery pack. This will reduce the potential for injury to yourself and others.

Do not dispose of used battery packs in the household refuse or by burning them. Milwaukee Distributors offer to retrieve old batteries to protect our environment.

Do not store the battery pack together with metal objects (short circuit risk).

No metal parts must be allowed to enter the battery section of the charger (short circuit risk).

Use only 18 V chargers for charging 18 V battery packs. Do not use battery packs from other systems.

Never break open battery packs and chargers and store only in dry rooms. Keep dry at all times.

Battery acid may leak from damaged batteries under extreme load or extreme temperatures. In case of contact with battery acid wash it off immediately with soap and water. In case of eye contact rinse thoroughly for at least 10 minutes and immediately seek medical attention.

Warning! To reduce the risk of fire, personal injury, and product damage due to a short circuit, never immerse your tool, battery pack or charger in fluid or allow a fluid to flow inside them. Corrosive or conductive fluids, such as seawater, certain industrial chemicals, and bleach or bleach containing products, etc., can cause a short circuit.

SPECIFIED CONDITIONS OF USE

The nailer is intended for driving nails into wood or similar soft materials from a magazine containing a strip of suitable nails. The nails which can be safely loaded into the magazine for the product are described in the product specification table in this manual. Do not use any other type of nail or fixing with the nailer. Do not operate in contact actuation mode while working on scaffold, ladder or other platform where a change in working position is required. Use only full sequential mode in this case. The nailer should not be used for fixing electric cables.

Do not use this product in any other way as stated for normal use.

EC-DECLARATION OF CONFORMITY

We declare under our sole responsibility that the product described under "Technical Data" fulfills all the relevant provisions of the directives 2011/65/EU (RoHS), 2014/30/EU, 2006/42/EC and the following harmonized standards have been used:

EN 60745-1:2009+A11:2010
EN 60745-2-16:2010
EN 55014-1:2017+A11:2020

EN 55014-2:2015
EN IEC 63000:2018

Winnenden, 2020-10-29



Alexander Krug
Managing Director



Authorized to compile the technical file.

Techtronic Industries GmbH
Max-Eyth-Straße 10
71364 Winnenden
Germany

GB-DECLARATION OF CONFORMITY

We declare as the manufacturer under our sole responsibility that the product described under "Technical Data" fulfills all the relevant provisions of the following Regulations S.I. 2008/1597 (as amended), S.I. 2016/1091 (as amended), S.I. 2012/3032 (as amended) and that the following designated standards have been used:

BS EN 60745-1:2009+A11:2010
BS EN 60745-2-16:2010
BS EN 55014-1:2017+A11:2020
BS EN 55014-2:2015
BS EN IEC 63000:2018

Winnenden, 2020-10-29



Alexander Krug
Managing Director

Authorized to compile the technical file.

Techtronic Industries GmbH
Max-Eyth-Straße 10
71364 Winnenden
Germany

BATTERIES

Battery packs which have not been used for some time should be recharged before use.

Temperatures in excess remove of 50°C (122°F) reduce the performance of the battery pack. Avoid extended exposure to heat or sunshine (risk of overheating).

The contacts of chargers and battery packs must be kept clean.

For an optimum life-time, after use, the battery packs have to be fully charged.

To obtain the longest possible battery life remove the battery pack from the charger once it is fully charged.

"For battery pack storage longer than 30 days: Store the battery pack where the temperature is below 27°C and away from moisture

Store the battery packs in a 30% - 50% charged condition Every six months of storage, charge the pack as normal.

TRANSPORTING LITHIUM BATTERIES

Lithium-ion batteries are subject to the Dangerous Goods Legislation requirements.

Transportation of those batteries has to be done in accordance with local, national and international provisions and regulations.

- The user can transport the batteries by road without further requirements.
- Commercial transport of Lithium-Ion batteries by third parties is subject to Dangerous Goods regulations. Transport preparation and transport are exclusively to be carried out by appropriately trained persons and the process has to be accompanied by corresponding experts.

When transporting batteries:

- Ensure that battery contact terminals are protected and insulated to prevent short circuit.

- Ensure that battery pack is secured against movement within packaging.
- Do not transport batteries that are cracked or leak.

Check with forwarding company for further advice

OPERATION

There are two ways for working with this nailer (see also picture section):

Single Sequential Actuation:

Drive the fastener by pulling the trigger.

Contact (Bump) Actuation:

Hold the trigger and drive the fastener by pushing the nailer against the workpiece.

Reload Indicator

To indicate that the magazine is almost empty of fasteners (about 4-5 left), the workpiece contact will not compress, preventing operation under usual pressure. Install more fasteners to continue working.

Setting the Depth of Drive (see picture section)

Know what is behind your workpiece. A fastener could travel through the workpiece and out the other side, striking a bystander and causing serious injury. Lower the depth of drive to prevent the fastener from being pushed all the way through the workpiece.

REQUIRED DAILY TESTING

▲ WARNING: To reduce the risk of injury to yourself and others, test the tool before beginning work each day or if the tool is dropped, received a sharp blow, been run over, etc. Complete the following checklist IN ORDER. If the tool does not work as it should, contact a MILWAUKEE service facility immediately.

Always point tool away from yourself and others.

1. Remove battery pack.
WARNING! Always point the tool away from yourself and others when installing fasteners. Failure to do so could result in injury.
2. Check all screws, bolts, nuts, and pins on the tool. Any loose fasteners must be tightened.
3. Pull back the fastener pusher on the magazine (to override the Reload Indicator) and press the workpiece contact against a workpiece. It must move smoothly.
4. With the workpiece contact pressed against the workpiece, pull the trigger. It must move smoothly.
5. Insert battery pack.
6. Select the Single Sequential Actuation Operation. Without pulling the trigger, pull back the fastener pusher on the magazine (to override the Reload Indicator) and press the workpiece contact against a workpiece. The tool must not operate. Holding the workpiece contact away from the workpiece, pull back the fastener pusher on the magazine (to override the Reload Indicator). Pull and hold the trigger for 5 seconds. The tool must not operate. Continue to pull and hold the trigger and push the workpiece contact against a workpiece. The tool must not operate. Without pulling the trigger, pull back the fastener pusher on the magazine (to override the Reload Indicator) and press the workpiece contact against a workpiece. Pull the trigger. The tool must operate. Release the trigger. The driver must move up.
7. Select the Contact Actuation Operation. Holding the workpiece contact away from the workpiece, pull back the fastener pusher on the magazine (to override the Reload Indicator) and pull the trigger. The tool must not operate. Continue to pull and hold the trigger and push the workpiece contact against a workpiece. The tool must operate.
8. If all previous tests work properly, set the tool for your work. Select the operation and load fastener strips.
9. Set the depth of drive according to the "Setting the Depth of Drive" section and see picture section.
10. If all tests operate properly, the tool is ready for use. Repeat these tests before use each day or if the tool is dropped, received a sharp blow, been run over, jammed, etc.















MAINTENANCE

The ventilation slots of the machine must be kept clear at all times.

Use only Milwaukee accessories and Milwaukee spare parts. Should components need to be replaced which have not been described, please contact one of our Milwaukee service agents (see our list of guarantee/service addresses).

If needed, an exploded view of the tool can be ordered. Please state the machine type printed as well as the six-digit No. on the label and order the drawing at your local service agents or directly at: Techtronic Industries GmbH, Max-Eyth-Straße 10, 71364 Winnenden, Germany.

SYMBOLS

	CAUTION! WARNING! DANGER!
	Remove the battery pack before starting any work on the machine.
	Please read the instructions carefully before starting the machine.
	Always wear goggles when using the machine.
	Wear gloves!
	Wear ear protectors!
	Keep hands away!
	Do not dispose electric tools, batteries/rechargeable batteries together with household waste material. Electric tools and batteries that have reached the end of their life must be collected separately and returned to an environmentally compatible recycling facility. Check with your local authority or retailer for recycling advice and collection point.
	No-load speed
	Volts
	Direct current
	European Conformity Mark
	British Conformity Mark
	Ukraine Conformity Mark
	EurAsian Conformity Mark



МАГАЗИН
БАШ МАЙСТОРА®
ПРОФЕСИОНАЛНИ РЕШЕНИЯ

Copyright 2020

Techtronic Industries GmbH
Max-Eyth-Str. 10
71364 Winnenden
Germany

+49 (0) 7195-12-0

www.milwaukeetool.eu

Techtronic Industries (UK) Ltd
Fieldhouse Lane
Marlow Bucks SL7 1HZ
UK



(10.20)

4100 4702 05