

Milwaukee®

Nothing but **HEAVY DUTY**®

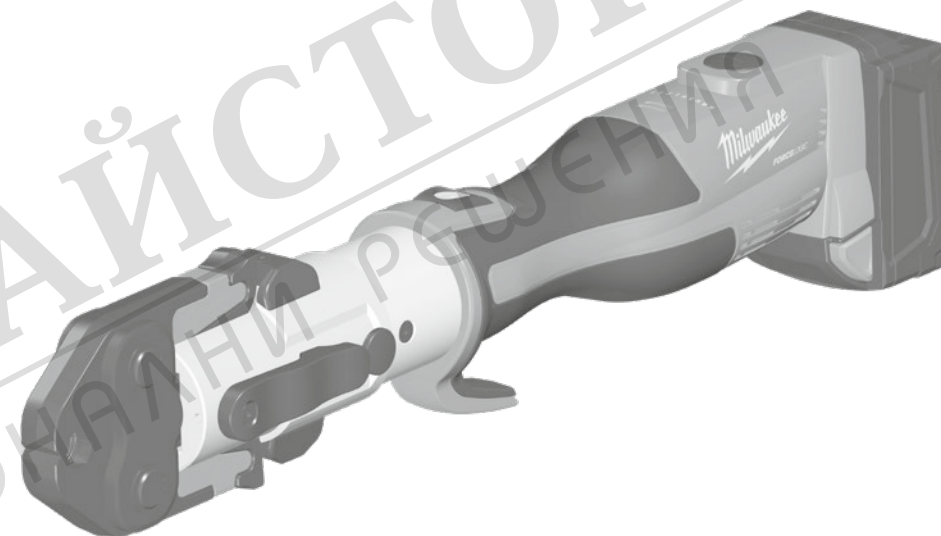

МАГАЗИН
БАШ
ПРОФЕСИОНАЛНИ РОЗЕННИК
МАЙСТОРА

M18 BLHPTXL

Original instructions
Originalbetriebsanleitung
Notice originale
Istruzioni originali
Manual original
Oorspronkelijke gebruiksaanwijzing
Original brugsanvisning
Original bruksanvisning
Bruksanvisning i original
Alkuperäiset ohjeet

Πρωτότυπο οδηγιών χρήσης
Orijinal işletme talimatı
Původním návodem k používání
Pôvodný návod na použitie
Instrukcją oryginalną
Eredeti használati utasítás
Izvirna navodila
Originalne pogonske upute
Instrukcijām oriģinālvalodā
Originali instrukcija

Algupärane kasutusjuhend
Оригинальное руководство по эксплуатации
Оригинално ръководство за експлоатация
Instrucțiuni de folosire originale
Оригинален прирачник за работа
Оригинал інструкції з експлуатації
التعليمات الأصلية

ENGLISH	Picture section with operating description and functional description	Page	4	Text section with Technical Data, important Safety and Working Hints and description of Symbols	Page	18
DEUTSCH	Bildteil mit Anwendungs- und Funktionsbeschreibungen	Seite	4	Textteil mit Technischen Daten, wichtigen Sicherheits- und Arbeitshinweisen und Erklärung der Symbole.	Seite	21
FRANÇAIS	Partie imagée avec description des applications et des fonctions	Page	4	Partie textuelle avec les données techniques, les consignes importantes de sécurité et de travail ainsi que l'explication des pictogrammes.	Page	24
ITALIANO	Sezione illustrata con descrizione dell'applicazione e delle funzioni	Pagina	4	Sezione testo con dati tecnici, importanti informazioni sulla sicurezza e sull'utilizzo, spiegazione dei simboli.	Pagina	27
ESPAÑOL	Sección de ilustraciones con descripción de aplicación y descripción funcional	Página	4	Sección de texto con datos técnicos, indicaciones importantes de seguridad y trabajo y explicación de los símbolos.	Página	30
PORTUGUES	Parte com imagens explicativas contendo descrição operacional e funcional	Página	4	Parte com texto explicativo contendo Especificações técnicas, avisos de segurança e de operação e a descrição dos símbolos.	Página	33
NEDERLANDS	Beeldgedeelte met toepassings- en functiebeschrijvingen	Pagina	4	Tekstgedeelte met technische gegevens, belangrijke veiligheids- en arbeidsinstructies en verklaring van de symbolen.	Pagina	36
DANSK	Billedel med anvendelses- og funktionsbeskrivelser	Side	4	Tekstdel med tekniske data, vigtige sikkerheds- og arbejdsanvisninger og symbolforklaring.	Side	39
NORSK	Billedel med bruks- og funksjonsbeskrivelse	Side	4	Tekstdel med tekniske data, viktige sikkerhets- og arbeidsinstruksjoner og forklaring av symbolene.	Side	42
SVENSKA	Bilddel med användnings- och funktionsbeskrivning	Sidan	4	Textdel med tekniska informationer, viktiga säkerhets- och användningsinstruktioner samt symbolförklaringar.	Sidan	45
SUOMI	Kuvasivut käyttö- ja toimintakuvaus	Sivu	4	Tekstisivut: tekniset tiedot, tärkeät turvallisuus- ja työskentelyohjeet sekä merkkiin selitykset.	Sivu	48
ΕΛΛΗΝΙΚΑ	Τμήμα εικόνων με περιγραφές χρήσης και λειτουργίας	Σελίδα	4	Τμήμα κειμένου με τεχνικά χαρακτηριστικά, σημαντικές υποδείξεις ασφαλείας και εργασίας και εξήγηση των συμβόλων.	Σελίδα	51
TÜRKÇE	Resim bölümü Uygulama ve fonksiyon açıklamaları ile birlikte	Sayfa	4	Teknik bilgileri, önemli güvenlik ve çalışma açıklamalarını ve de sembollerin açıklamalarını içeren metin bölümü.	Sayfa	54
ČESKY	Obrazová část s popisem aplikací a funkcí	Stránka	4	Textová část s technickými daty, důležitými bezpečnostními a pracovními pokyny a s vysvětlivkami symbolů	Stránka	57
SLOVENSKY	Obrazová časť s popisom aplikácií a funkcií	Stránka	4	Textová časť s technickými dátami, dôležitými bezpečnostnými a pracovnými pokynmi a s vysvetlivkami symbolov	Stránka	60
POLSKI	Część rysunkowa z opisami zastosowania i działania	Strona	4	Część opisowa z danymi technicznymi, ważnymi wskazówkami dotyczącymi bezpieczeństwa i pracy oraz objaśnieniami symboli.	Strona	63
MAGYAR	Képes részalkalmazási- és működési leírásokkal	Oldal	4	Szöveges rész műszaki adatokkal, fontos biztonsági- és munkavégzési útmutatásokkal, valamint a szimbólumok magyarázata.	Oldal	66
SLOVENŠČINA	Del slikez opisom uporabe in funkcij	Stran	4	Del besedila s tehničnimi podatki, pomembnimi varnostnimi opozorili in delovnimi navodili in pojasnili simbolov.	Stran	69
HRVATSKI	Dio sa slikama opisima primjene i funkcija	Stranica	4	Dio štiva sa tehničkim podacima, važnim sigurnosnim i radnim uputama i objašnjenjem simbola.	Stranica	72
LATVISKI	Attēla daļa ar lietošanas un funkciju aprakstiem	Lappuse	4	Teksta daļa ar tehniskajiem parametriem, svarīgiem drošības un darbības norādījumiem, simbolu atšifrējumiem.	Lappuse	75
LIETUVIŠKAI	Paveikslėlio dalis su vartojimo instrukcija ir funkcijų aprašymais	Puslapis	4	Teksto dalis su techniniais duomenimis, svarbiomis saugumo ir darbo instrukcijomis bei simbolių paaiškinimais.	Puslapis	78
EESTI	Pildiosa kasutusjuhendi ja funktsioonide kirjeldusega	Lehekülg	4	Tekstiosa tehniliste näitajate, oluliste ohutus- ja tööjuhenditega ning sümbolite kirjeldustega.	Lehekülg	81
РУССКИЙ	Раздел иллюстраций с описанием эксплуатации и функций	Страница	4	Текстовый раздел, включающий технические данные, важные рекомендации по безопасности и эксплуатации, а также описание используемых символов.	Страница	84
БЪЛГАРСКИ	Част със снимки с описание за приложение и функции	Страница	4	Част с текст с технически данни, важни указания за безопасност и работа и разяснение на символите.	Страница	87
ROMÂNĂ	Secvența de imagine cu descrierea utilizării și a funcționării	Pagina	4	Porțiune de text cu date tehnice, indicații importante privind siguranța și modul de lucru și descrierea simbolurilor.	Pagina	90
МАКЕДОНСКИ	Дел со сликисо описи за употреба и функционирање	Страница	4	Текстуален дел со Технички карактеристики, важни безбедносни и работни упатства и објаснување на символите.	Страница	93
УКРАЇНСЬКА	Частина з зображеннями з описом робіт та функцій	Сторінка	4	Текстова частина з технічними даними, важливими вказівками з техніки безпеки та експлуатації і поясненням символів.	Сторінка	96
عربي	قسم الصور يوجد به الوصف التشغيلي والوظيفي	الصفحة	4	القسم النصي المزود بالبيانات الفنية والنصائح الهامة للسلامة والعمل ووصف الرموز	الصفحة	101

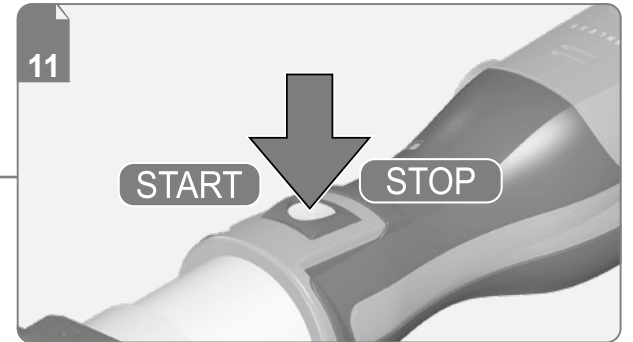
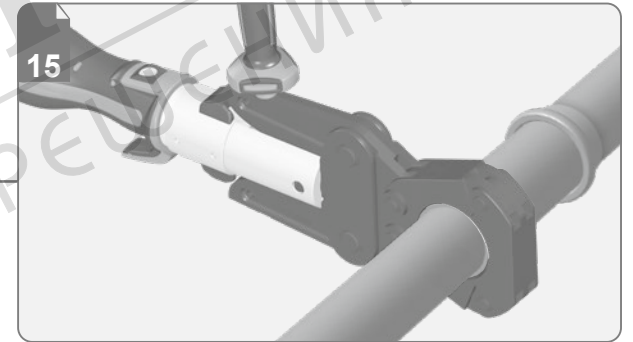
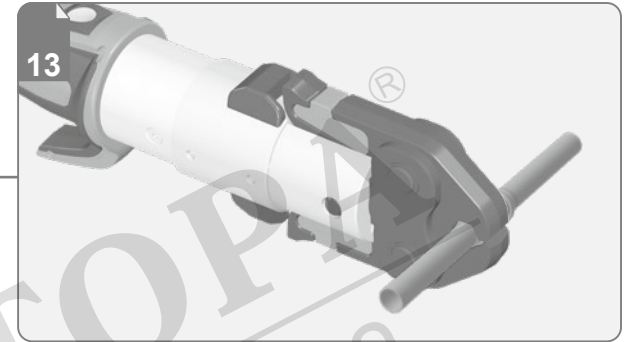
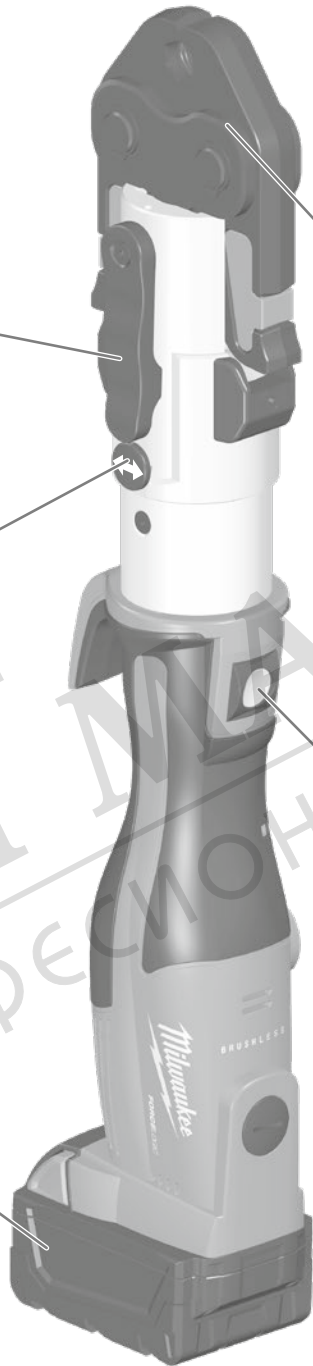
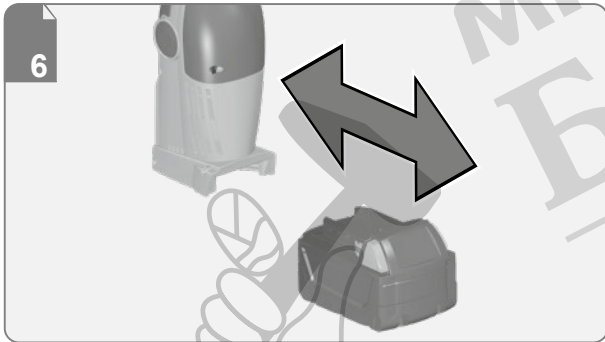
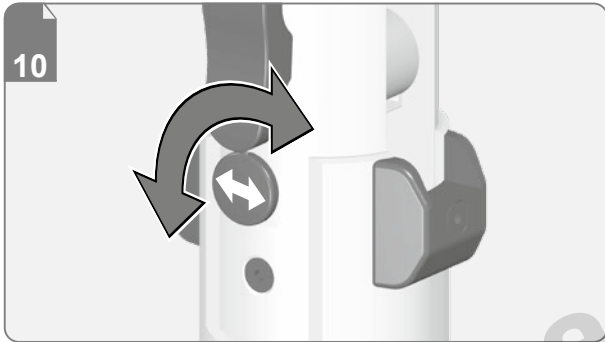
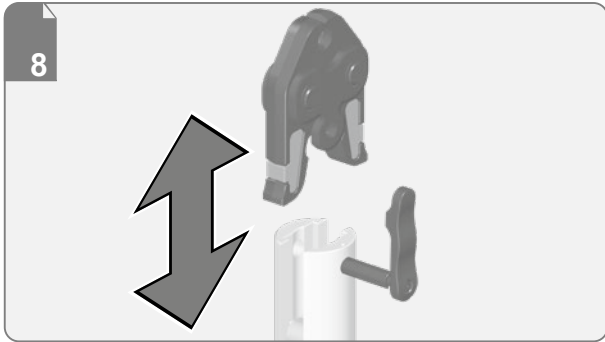



1

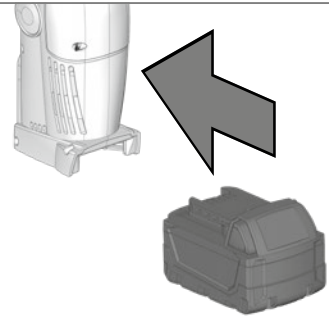

2



1

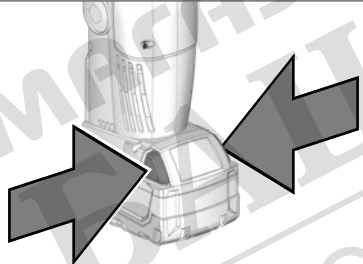

2

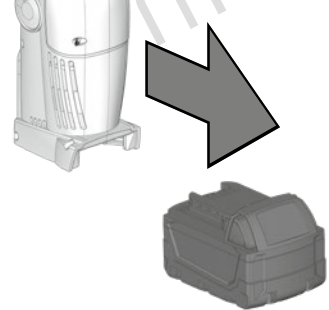

 Remove the battery pack before starting any work on the machine.
Vor allen Arbeiten an der Maschine den Wechselakku herausnehmen.

Avant tous travaux sur la machine retirer l'accu interchangeable.

Prima di iniziare togliere la batteria dalla macchina.

Retire la batería antes de comenzar cualquier trabajo en la máquina.

Antes de efectuar cualquier intervención na máquina retirar o bloco acumulador.

Voor alle werkzaamheden aan de machine de akku verwijderen.

Ved arbejde inden i maskinen, bør batteriet tages ud.

Ta ut vekslebatteriet før du arbeider på maskinen

Drag ur batteripaket innan arbete utföres på maskinen.

Tarkista pistotulppa ja verkkojohto mahdollisilta vaurioilta. Viat saa korjata vain alan erikoismies.

Πριν από κάθε εργασία στη μηχανή αφαιρέστε την ανταλλακτική μπαταρία.

Aletin kendingde bir çalışma yapmadan önce kartuş aküyü çıkarın.

Před zahájením veškerých prací na vrtacím šroubovákú vyjmout výměnný akumulátor.

Pred každou prací na stroji výměnný akumulátor vytáhnout.

Przed przystąpieniem do jakichkolwiek prac na elektronarzędziu należy wyjąć wkładkę akumulatorową.

Karbantartás, javítás, tisztítás, stb. előtt az akkumulátort ki kell venni a készülékből.

Pred deli na stroju izvlécite izmenljivi akumulator.

Prije svih radova na stroju izvaditi bateriju za zamjenu.

Pirms mašīnai veikt jebkāda veida apkopes darbus, ir jāizņem ārā akumulators.

Prieš atlikdami bet kokius darbus įrenginyje, išimkite keičiamą akumuliatorių.

Enne kõiki töid masina kallal võtke vahetatav aku välja.

Выньте аккумулятор из машины перед проведением с ней каких-либо манипуляций.

Преди започване на каквото е да е работи по машината извадете акумулатора.









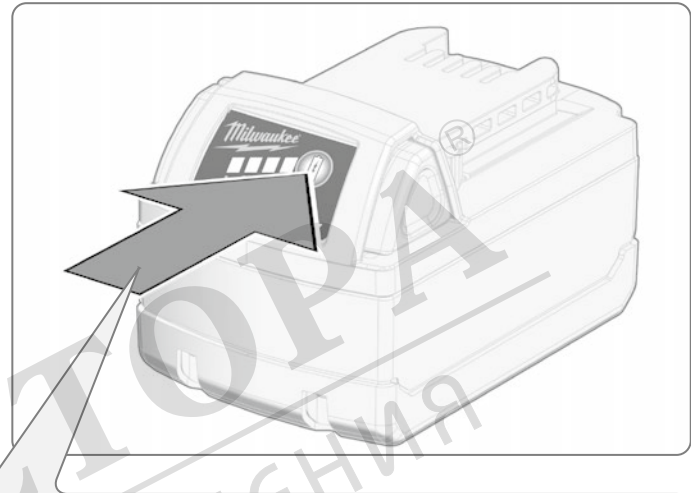



Scoateți acumulatorul înainte de a începe orice intervenție pe mașină.

Отстранете ја батеријата пред да започнете да ја користите машината.



Перед будь-якими роботами на машині ви́йняти змінну акумуляторну батарею.

قبل بدء العمل على الجهاز، قم بإزالة حزمة البطارية قبل البدء في أي أعمال على الجهاز.





		75-100 %
		50-75 %
		25-50 %
		10-25 %
		< 10 %
		





























2021

Jan	Feb	Mar	Apr	May	June
July	Aug	Sept	Oct	Nov	Dec





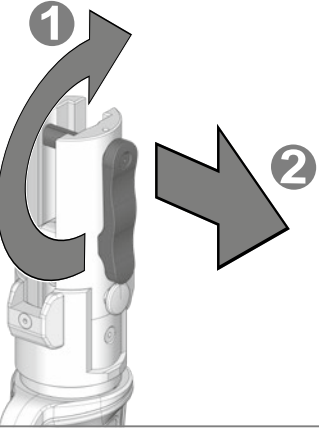

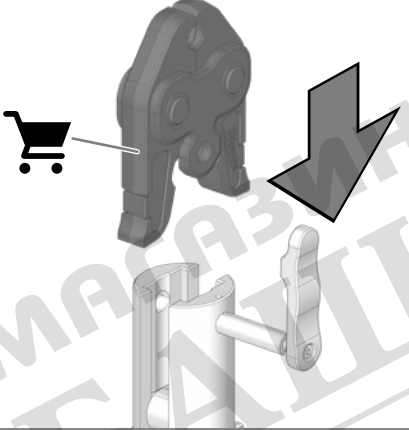

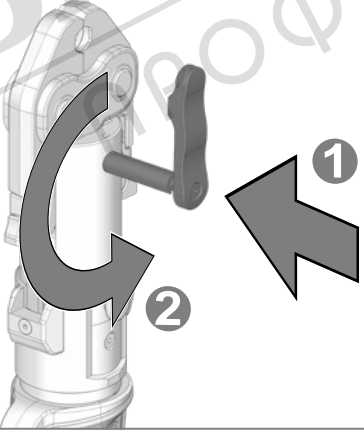

















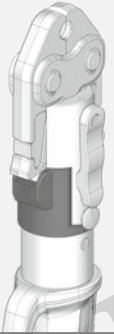

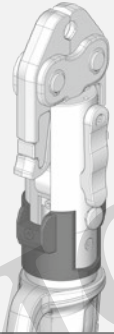

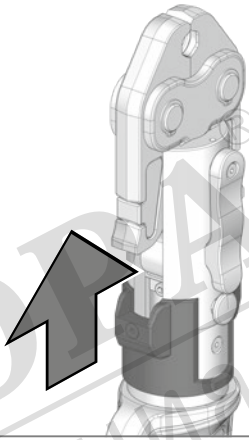



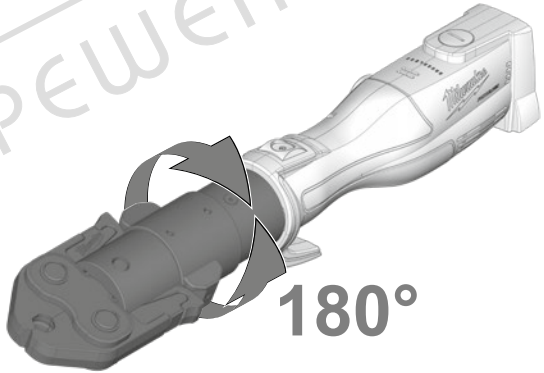

180°

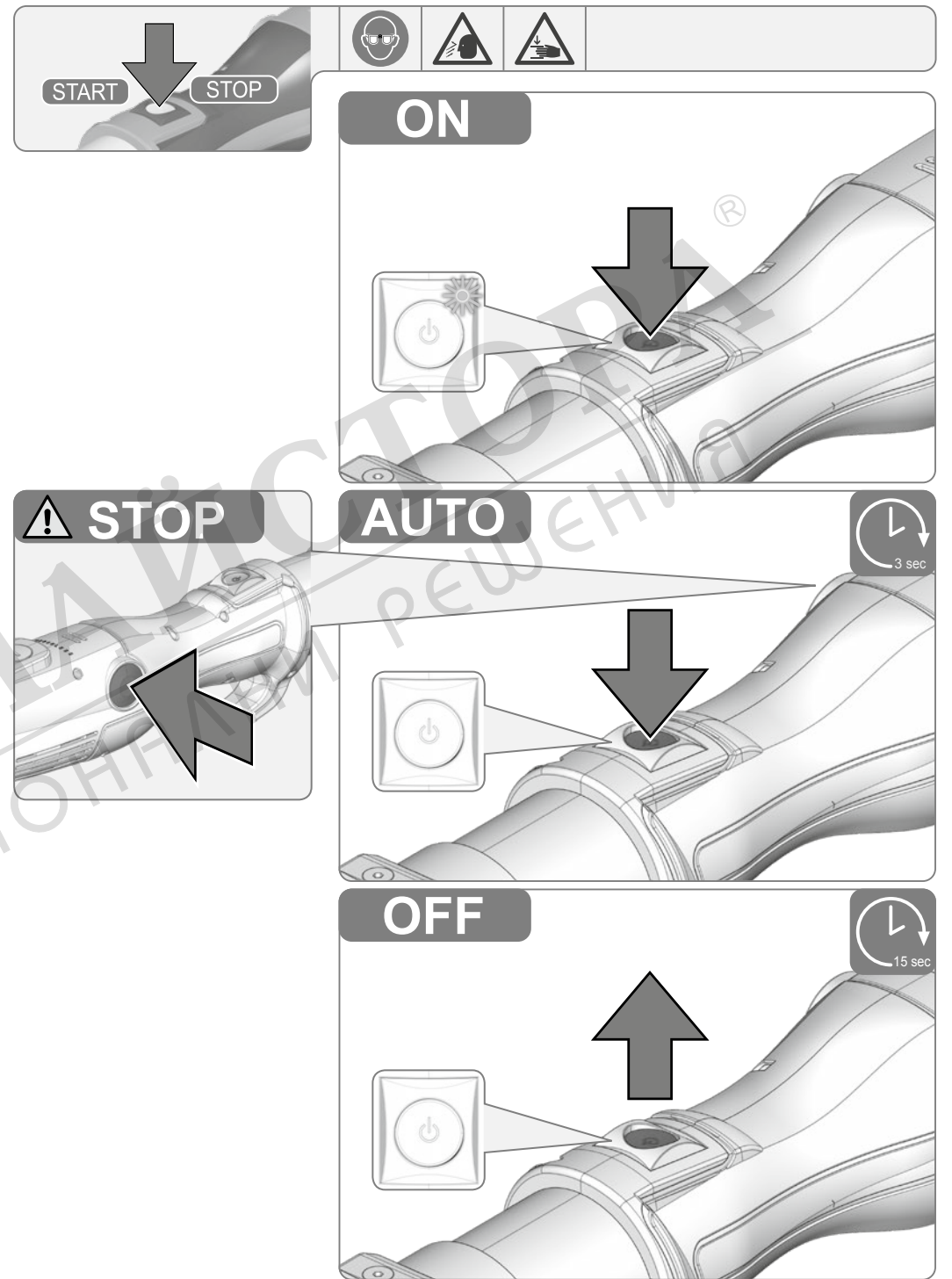
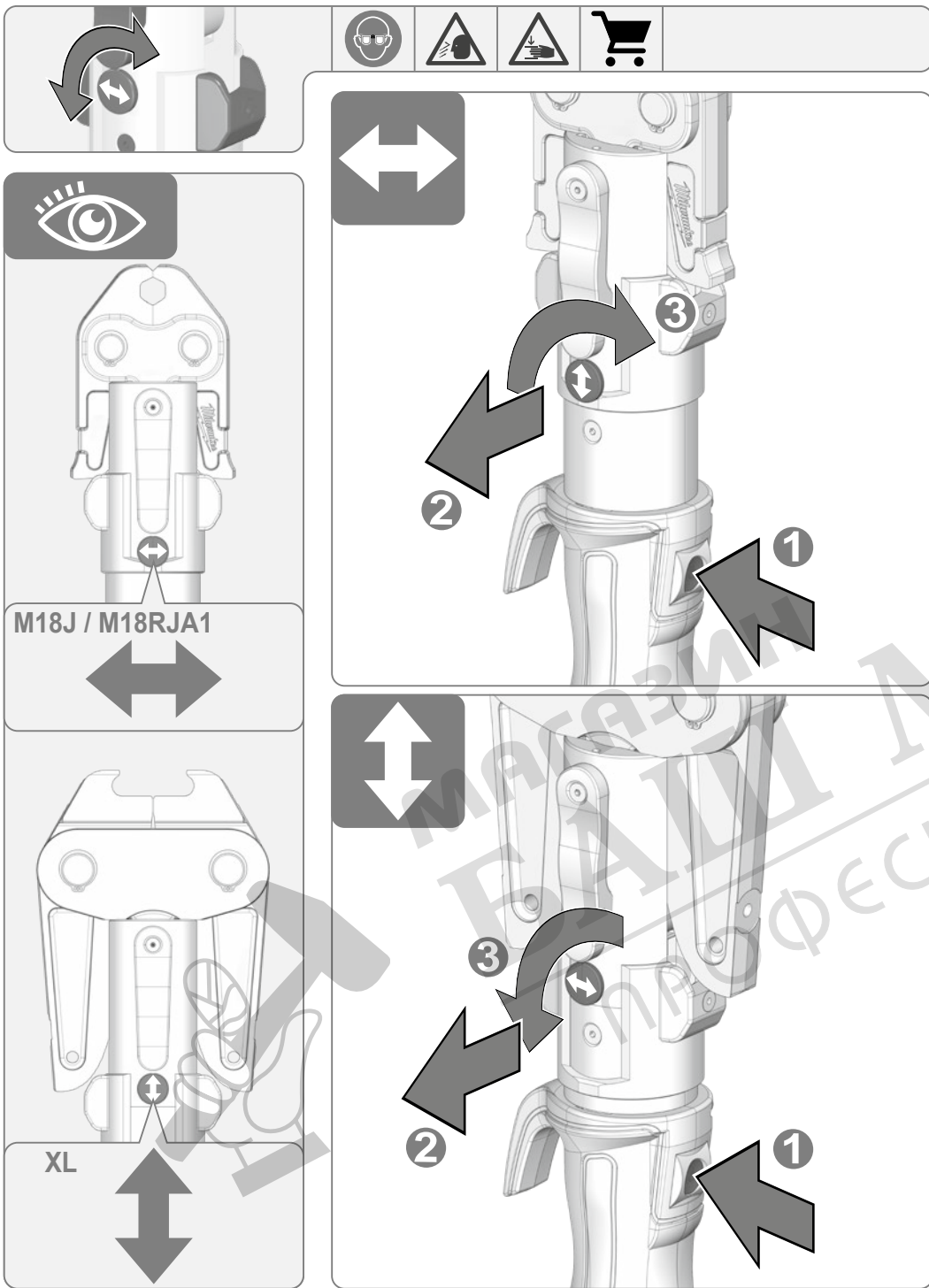

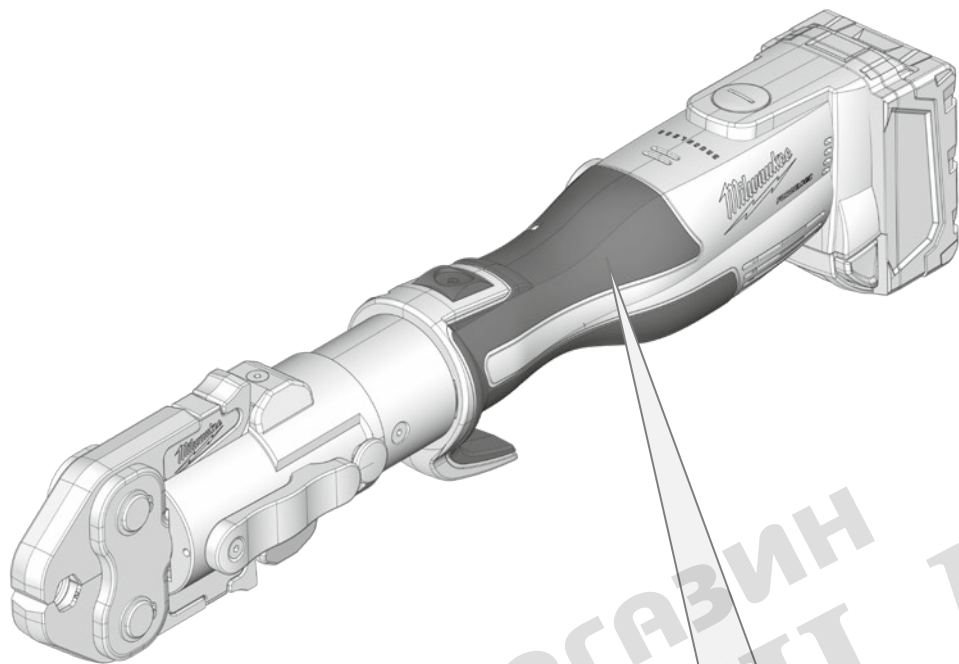

Insulated gripping surface
 Isolierte Grifffläche
 Surface de prise isolée
 Superficie di presa isolata
 Superficie de agarre con aislamiento
 Superfície de pega isolada
 Geïsoleerde handgrepen
 Isolerede gripbeholder
 Isolert gripeflate
 Isolerad greppytta
 Eristetty tarttumapinta
 Μονωμένη επιφάνεια λαβής

İzolasyonlu tutma yüzeyi
 Izolovaná uchopovací plocha
 Izolovaná úchopná plocha
 Izolowana powierzchnia uchwytu
 Szigetelt fogófelület
 Izolirana prijemalna površina
 Izolirana površina za držanje
 Izolēta satveršanas virsma
 Izoliuotas rankenos paviršius
 Isoleeritud pideme piirkond
 Изолированная поверхность ручки
 Ισολιριρα ηοβήρηνη ηα ηωαηαηε

Suprafață de prindere izolată
 Изолирана површина на дршката
 Изольована поверхня ручки
 مساحة المقبض معزولة

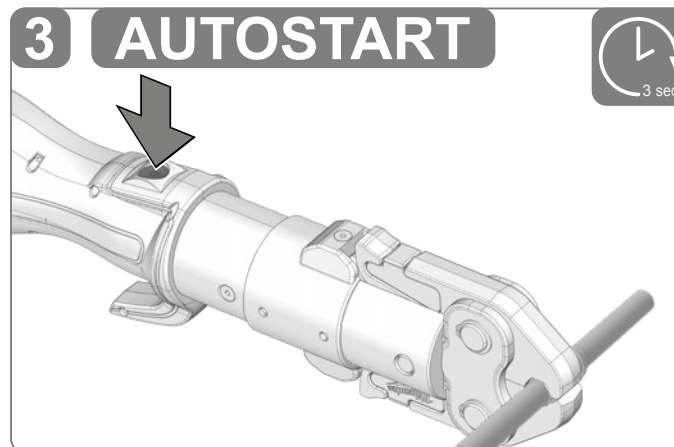
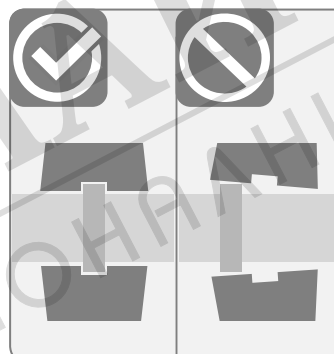
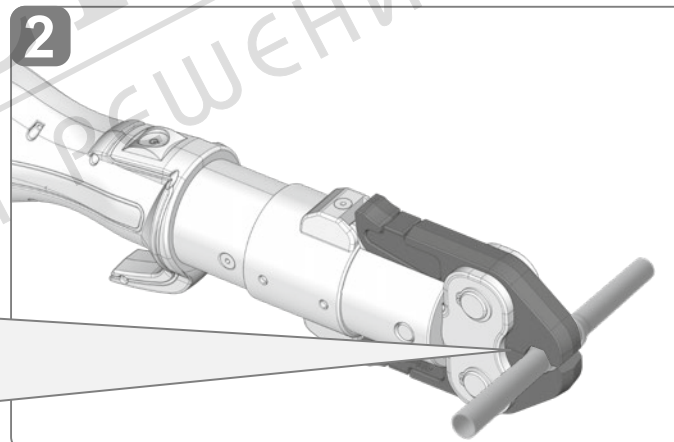
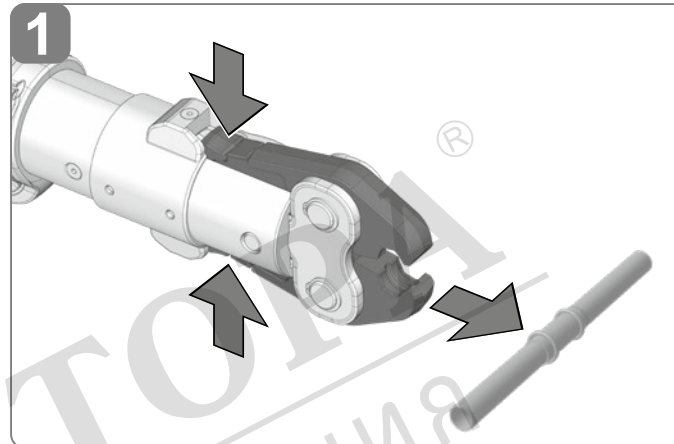
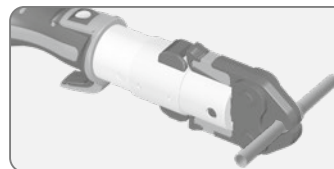

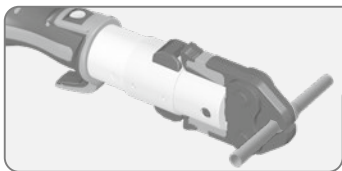

4 AUTOSTOP

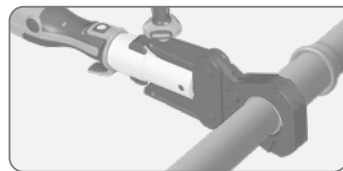
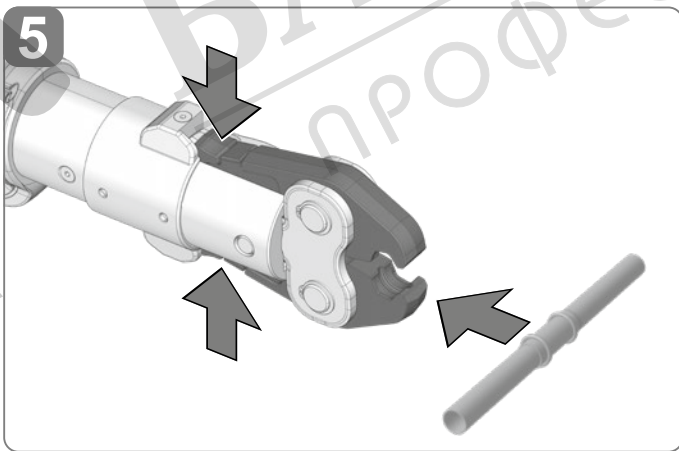
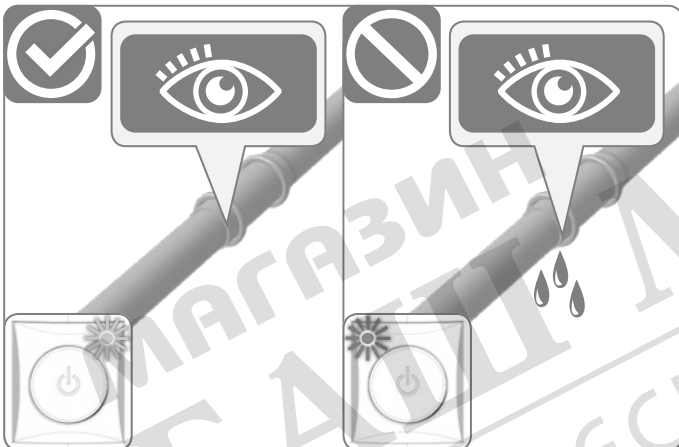
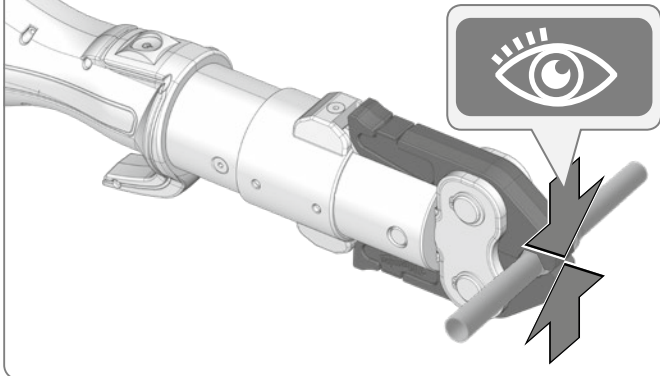

1



2

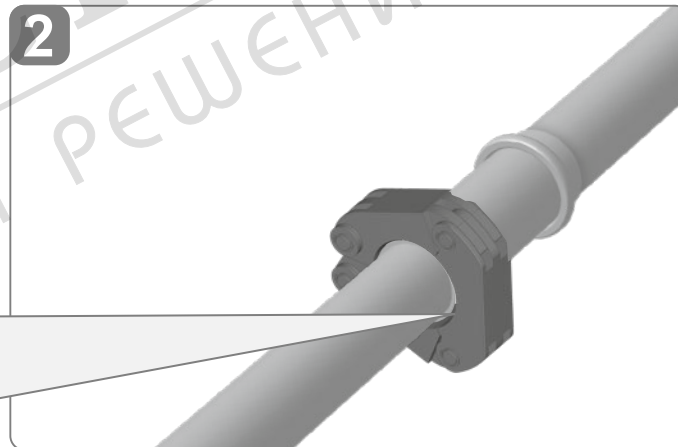
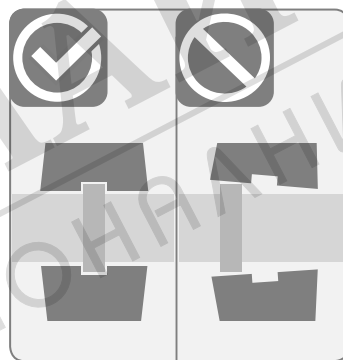

3

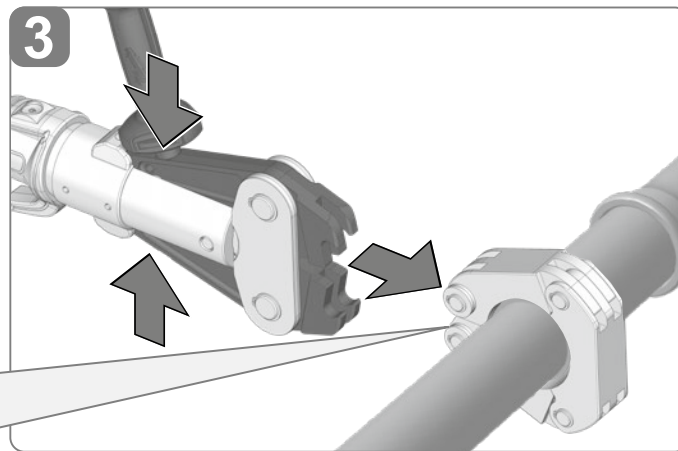
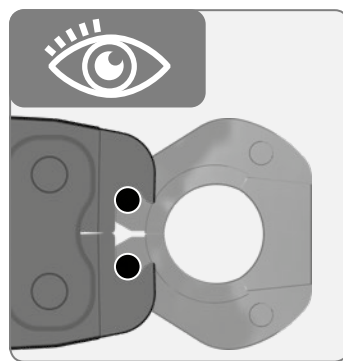

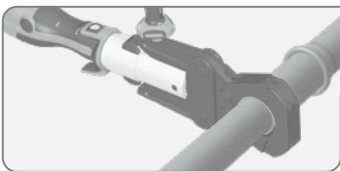

4 AUTOSTART

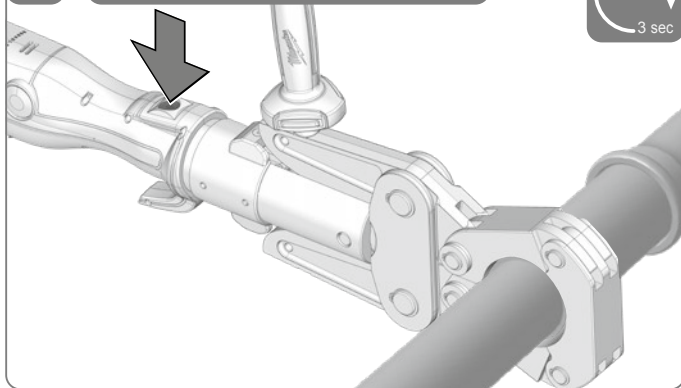

5 AUTOSTOP

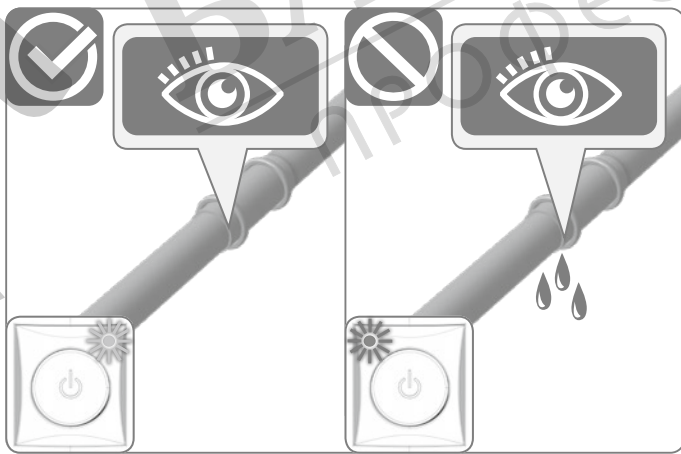
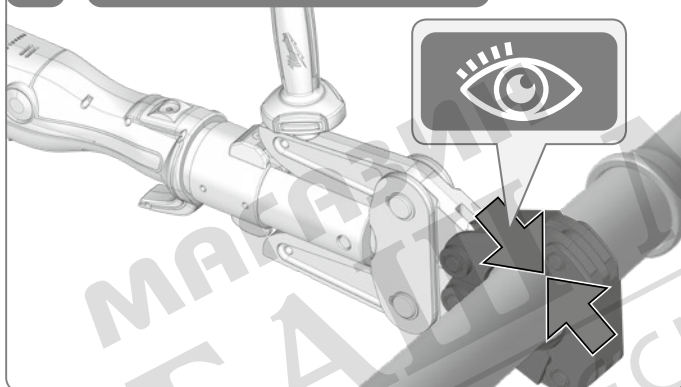

6

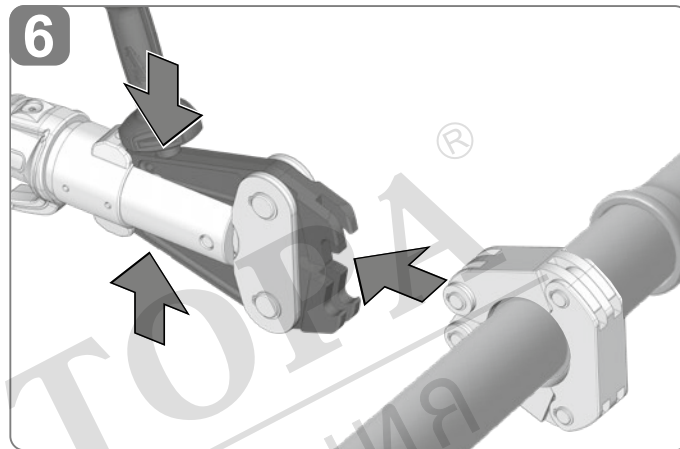

7

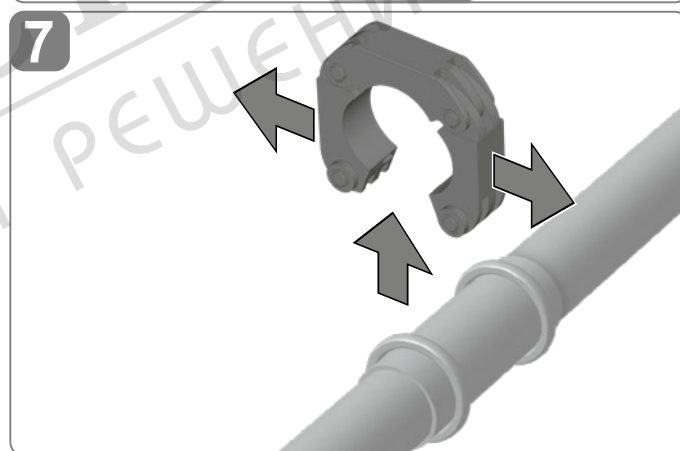

TECHNICAL DATA		M18 BLHPTXL	
Type	Press device		
Production code	4836 83 01 XXXXXX MJJJJ		
Battery voltage	18 V \approx		
Power consumption	450 W		
Nominal force	32 kN		
Compression range:			
Ø Copper and Stainless	100 mm		
Ø Iron Pipe and Stainless	50 mm		
Ø Black Iron Pipe	50 mm		
Weight according EPTA-Procedure 01/2014 (Li-Ion 2.0 Ah ... 12.0 Ah)	3,6 ... 4,7 kg		
Weight (tool only)	3,21 kg		
Recommended Ambient Operating Temperature	-18 ... +50 °C		
Recommended battery types	M18B...; M18HB...		
Recommended charger	M12-18...; M1418C6		
Noise information: Measured values determined according to EN 60745. Typically, the A-weighted noise levels of the tool are:			
Sound pressure level / Uncertainty K	78,0 dB (A) / 3 dB (A)		
Sound power level / Uncertainty K	89,0 dB (A) / 3 dB (A)		
Wear ear protectors!			
Vibration information: Vibration total values (triaxial vector sum) determined according to EN 60745			
Vibration emission value a_n / Uncertainty K	< 2,5 m/s ² / 1,5 m/s ²		

WARNING!

The vibration and noise emission level given in this information sheet has been measured in accordance with a standardized test given in EN 60745 and may be used to compare one tool with another. It may be used for a preliminary assessment of exposure.

The declared vibration and noise emission level represents the main applications of the tool. However if the tool is used for different applications, with different accessories or poorly maintained, the vibration and noise emission may differ. This may significantly increase the exposure level over the total working period.

An estimation of the level of exposure to vibration and noise should also take into account the times when the tool is switched off or when it is running but not actually doing the job. This may significantly reduce the exposure level over the total working period.

Identify additional safety measures to protect the operator from the effects of vibration and/or noise such as: maintain the tool and the accessories, keep the hands warm, organization of work patterns.

WARNING! Read all safety warnings and all instructions. Failure to follow the warnings and instructions may result in electric shock, fire and/or serious injury.

Save all warnings and instructions for future reference.

PRESS DEVICE SAFETY WARNINGS

Use protective equipment. Always wear safety glasses when working with the machine. The use of protective clothing is recommended, such as dust mask, protective gloves, sturdy non-slip footwear, helmet and ear defenders.

Never hold your fingers or other body parts in the working area of the cylinder or the press jaws.

Do not hold the jaw levers with your hands during the pressing operation.

Press tools and press devices must only be used by trained personnel.

Check the press tools and press devices for cracks and other signs of wear before each use.

Only use press tools and press devices that are in perfect technical condition.

Have damage repaired immediately by an authorised workshop.

The machine may only be used with a press jaw inserted into it.

In the event of problems during the pressing process, press the Emergency Stop button immediately and release the ON switch. The valve will open and the piston will return to its initial position.

Compliance with the specified service work and service intervals is mandatory.

Remove the battery pack before starting any work on the appliance.

ADDITIONAL SAFETY AND WORKING INSTRUCTIONS

Use only system-compatible press fittings and press jaws designed for them.

Consult the documents provided by the system supplier for handling and assembly instructions for fittings and pipes.

Check whether the nominal width of the press fitting corresponds to the nominal width of the press jaws.

Make sure that the press jaw is fully closed when pressing is complete.

Imperfect pipe joints must be compressed again using a new fitting.

After finishing the work, check the installation with appropriate testing equipment and assure that it is leakproof!

The press device is not suitable for continuous operation. Following 30 minutes of continuous operation, a short break of at least 15 minutes must be taken to allow the device to cool down.

WARNING! To reduce the risk of fire, personal injury, and product damage due to a short circuit, never immerse your tool, battery pack or charger in fluid or allow a fluid to flow inside them. Corrosive or conductive fluids, such as seawater, certain industrial chemicals, and bleach or bleach containing products, etc., can cause a short circuit.

Never break open battery packs and chargers and store only in dry rooms. Keep dry at all times.

Use only System M18 chargers for charging System M18 battery packs. Do not use battery packs from other systems.

SPECIFIED CONDITIONS OF USE

The devices and the press jaws are designed exclusively for the press-fitting of pipes and fittings for which the relevant press jaws are intended.

These press devices are intended exclusively for use with press jaws approved by Milwaukee in agreement with the system supplier.

Do not use the product in any way other than those stated for intended use.

RESIDUAL RISK

Even when the product is used as prescribed, it is still impossible to completely eliminate certain residual risk factors. The following hazards may arise in use and the operator should pay special attention to avoid the following:

- Injury caused by vibration. Hold the product by designated handles and restrict working time and exposure.
- Exposure to noise can cause hearing injury. Wear ear protection and limit exposure.
- Injury due to flying debris. Wear eye protection, heavy long trousers, gloves and substantial footwear at all times.
- Inhalation of toxic dusts.

NOTES FOR LI-ION BATTERIES

Use of Li-Ion batteries

Battery packs which have not been used for some time should be recharged before use.

Temperatures in excess of 50°C (122°F) reduce the performance of the battery pack. Avoid extended exposure to heat or sunshine (risk of overheating).

The contacts of chargers and battery packs must be kept clean.

For an optimum life-time, the battery packs have to be fully charged, after use.

To obtain the longest possible battery life remove the battery pack from the charger once it is fully charged.

For battery pack storage longer than 30 days:

Store the battery pack where the temperature is below 27°C and away from moisture

Store the battery packs in a 30% - 50% charged condition

Every six months of storage, charge the pack as normal.

Battery protection for Li-Ion batteries

In extremely high torque, binding, stalling and short circuit situations that cause high current draw, the tool will vibrate for about 5 seconds, the fuel gauge will flash, and then the tool will turn OFF.

To reset, release the trigger. Under extreme circumstances, the internal temperature of the battery pack could raise too much. If this happens, the fuel gauge will flash until the battery pack cooled down. After the lights go off, the work may continue.

Transporting Lithium Batteries

Lithium-ion batteries are subject to the Dangerous Goods Legislation requirements.

Transportation of those batteries has to be done in accordance with local, national and international provisions and regulations.

The user can transport the batteries by road without further requirements.

Commercial transport of Lithium-Ion batteries by third parties is subject to Dangerous Goods regulations. Transport preparation and transport are exclusively to be carried out by appropriately trained persons and the process has to be accompanied by corresponding experts.

When transporting batteries:

Ensure that battery contact terminals are protected and insulated to prevent short circuit.

Ensure that battery pack is secured against movement within packaging. Do not transport batteries that are cracked or leak. Check with forwarding company for further advice.

WORKING INSTRUCTIONS

Double crimping is required for M Profile 108 mm!

1. Press with: RJAXL-1 + RJ18XL-M108
2. Press with: RJAXL-2 + RJ18XL-M108

CLEANING

Clean dust and debris from openings. Keep handle clean, dry and free of oil or grease. Use only mild soap and a damp cloth to clean, since certain cleaning agents and solvents are harmful to plastics and other insulated parts. Some of these include gasoline, turpentine, lacquer thinner, paint thinner, chlorinated cleaning solvents, ammonia and household detergents containing ammonia. Never use flammable or combustible solvents around tools.

MAINTENANCE

Check that the press jaw and drive rolls move freely.

Clean and grease the press drives, locking bolts and press jaws when you have finished work.

Service and repair work may only be carried out by authorised specialist workshops.

The device contains hydraulic fluid. Hydraulic fluids pose a hazard to groundwater. Uncontrolled draining or improper disposal is punishable by law.

The next service deadline is indicated on the press device. This service must be performed at least every 2 years or at the latest when the LED display indicates that a service is due.

Replace worn press tools.















Use only Milwaukee accessories and Milwaukee spare parts. Should components need to be replaced which have not been described, please contact one of our Milwaukee service agents (see our list of guarantee/service addresses).

If needed, an exploded view of the tool can be ordered. Please state the Article No. as well as the machine type printed on the label and order the drawing at your local service agents or directly at: Techtronic Industries GmbH, Max-Eyth-Straße 10, 71364 Winnenden, Germany.

TROUBLESHOOTING

LED	Cause	Solution
Green LED flashing	The battery is not sufficiently charged to complete a pressing operation.	Charge the battery.
Red LED flashing	Device not within operating temperature range.	Bring device into operating temperature range (-10°C to 50°C)
Red LED on	Device fault	Retry operation. If Red LED remains lit, return the tool, charger and battery pack, to a MILWAUKEE service facility for repairs.
Green and Red LED flashing alternately	Service needed	Return the tool, charger and battery pack, to a MILWAUKEE service facility for maintenance.

SYMBOLS

	Please read the instructions carefully before starting the machine.
	CAUTION! WARNING! DANGER!
	Remove the battery pack before starting any work on the appliance.
	Always wear goggles when using the machine.
	WARNING! Risk of injury from ejected fragments
	Warning! Danger of crushing!
	Service label
	Accessory - Not included in standard equipment, available as an accessory.
	Do not dispose electric tools, batteries/rechargeable batteries together with household waste material. Electric tools and batteries that have reached the end of their life must be collected separately and returned to an environmentally compatible recycling facility. Check with your local authority or retailer for recycling advice and collection point.
V	Voltage
	Direct Current
	European Conformity Mark
	British Conformity Mark
	Ukraine Conformity Mark
	EurAsian Conformity Mark

МАГАЗИН МАЙСТОРА®
 БАШ МАЙСТОРА®
 ПРОФЕСІОНАЛНИ РЕШЕННЯ