

**Milwaukee**<sup>®</sup>

Nothing but **HEAVY DUTY**<sup>®</sup>.



**M12 BDD**  
**M12 BPD**

Original instructions

МАГАЗИН МАЙСТОРА<sup>®</sup>  
БАШЕНА  
ПРОФЕСИОНАЛНИ РЕШЕНИЯ



14 Text section with Technical Data, important Safety and Working Hints and description of Symbols

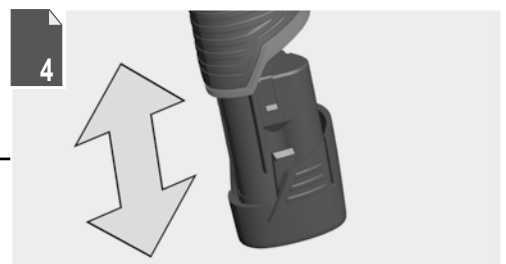
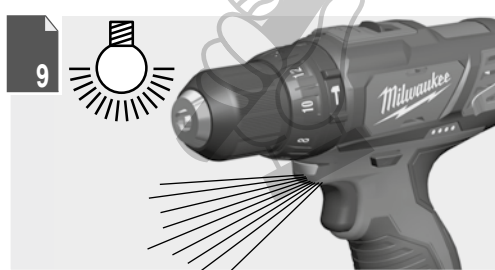
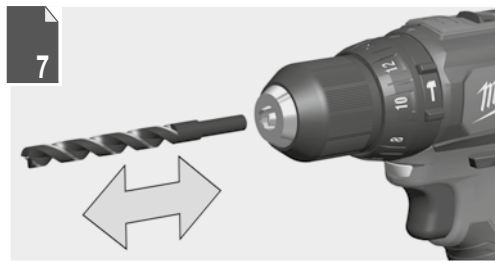
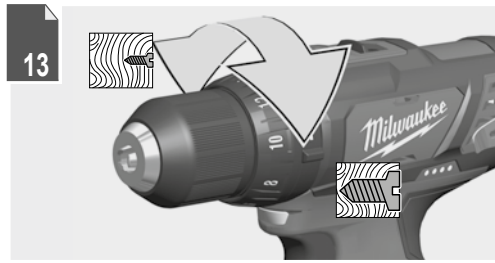

M12 BPD



Remove the battery pack before starting any work on the machine.

1

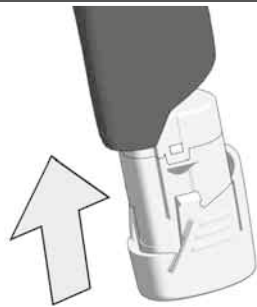

2



click

1



2

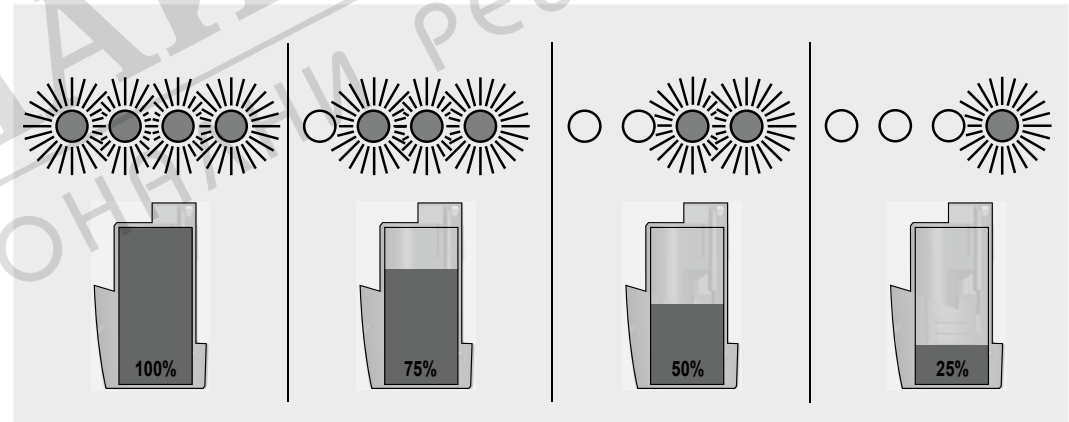
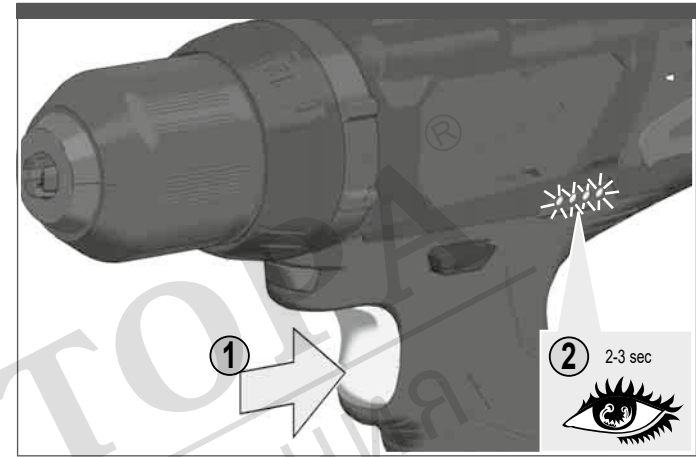
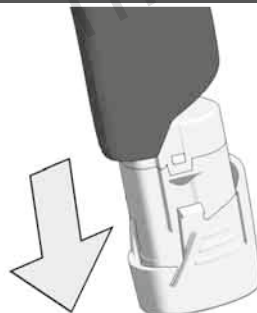

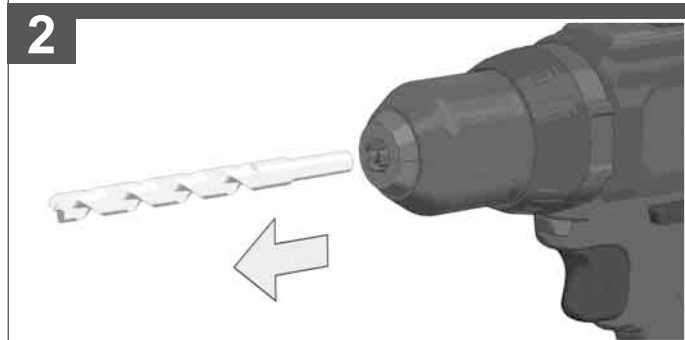
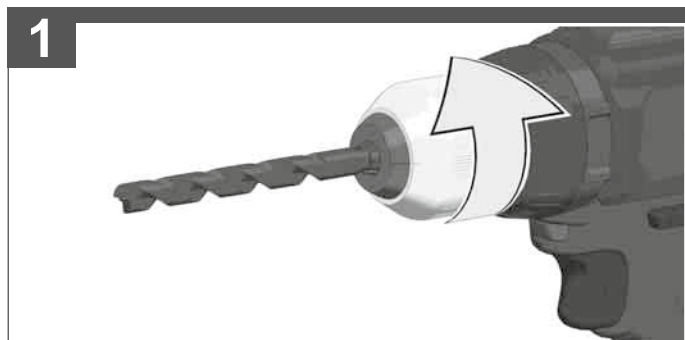
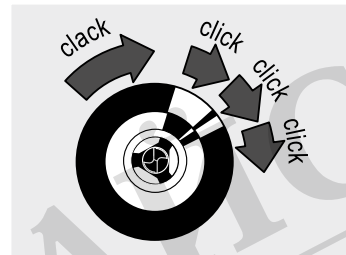
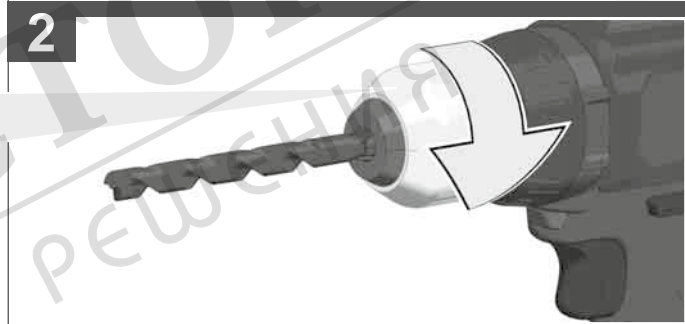
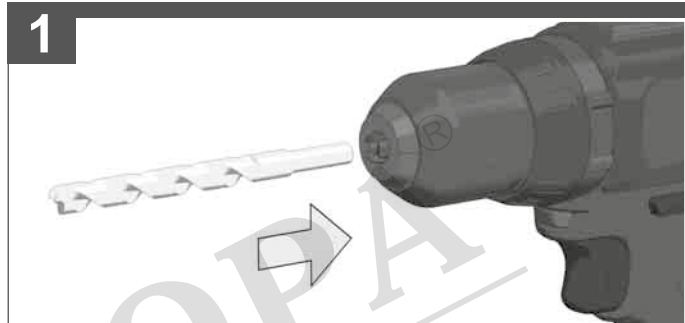
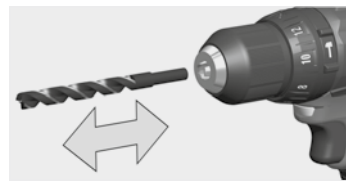
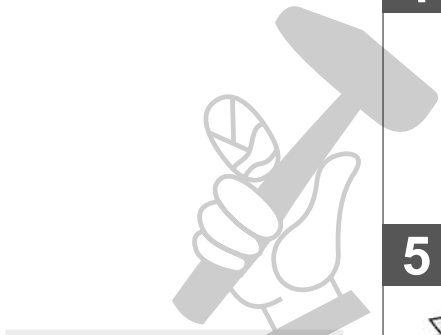
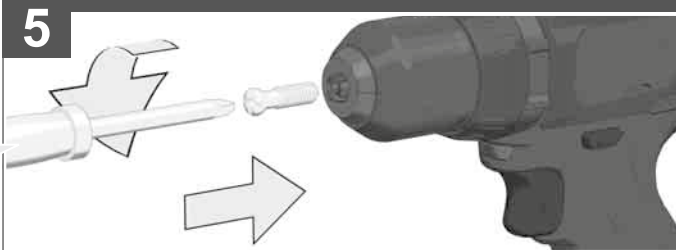
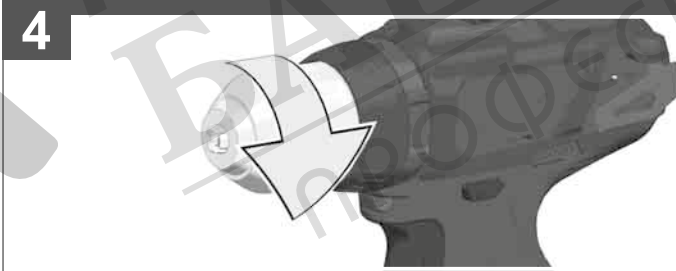
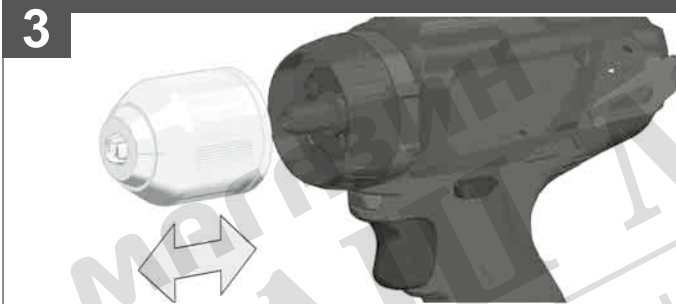
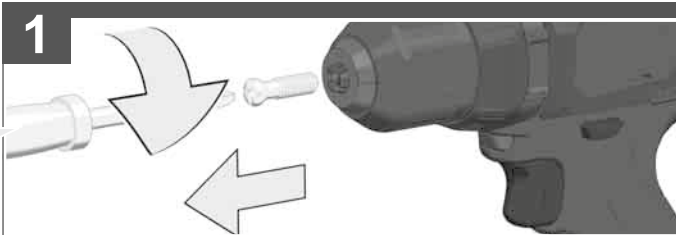

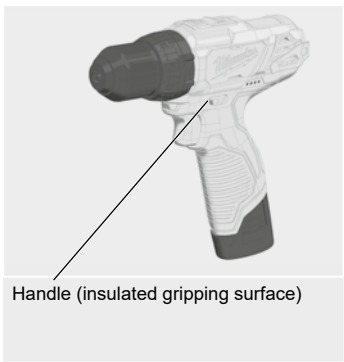

Handle (insulated gripping surface)

# START

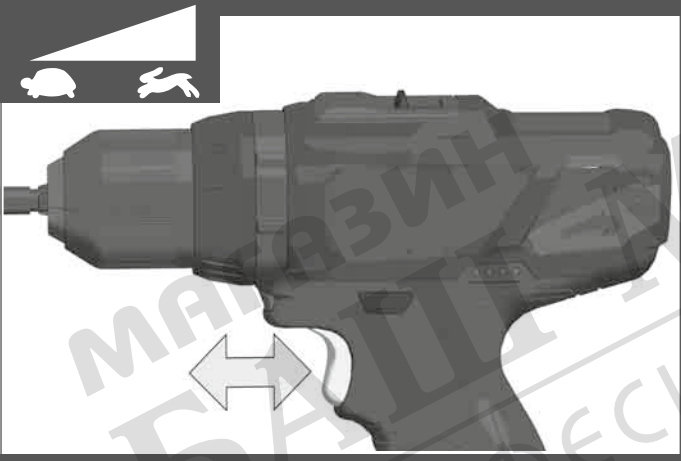

# STOP

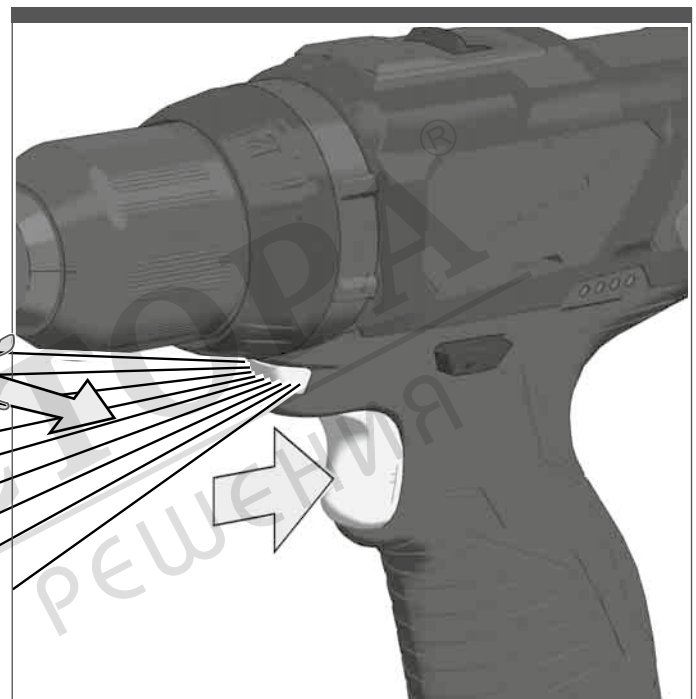
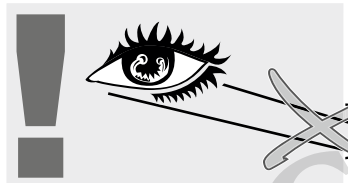
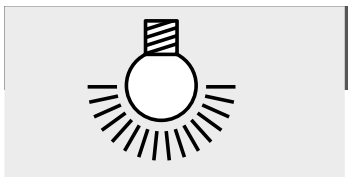

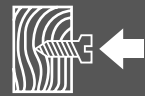

**LOCK**

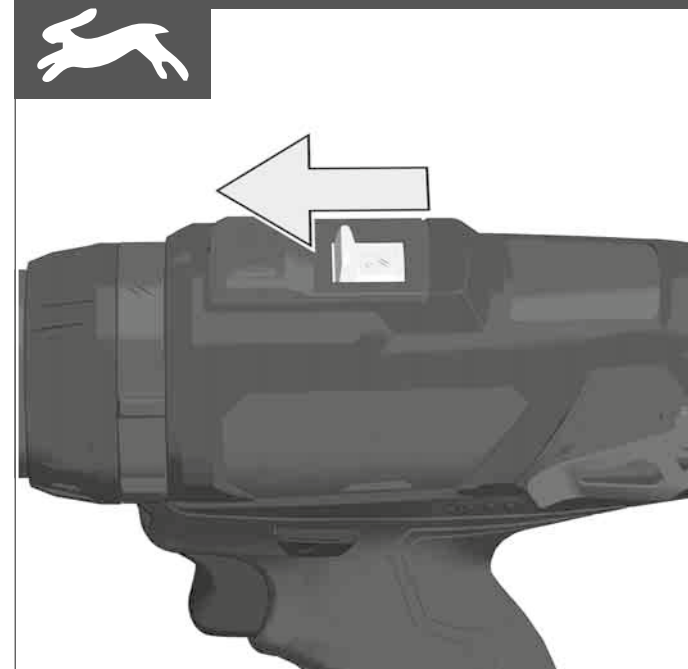
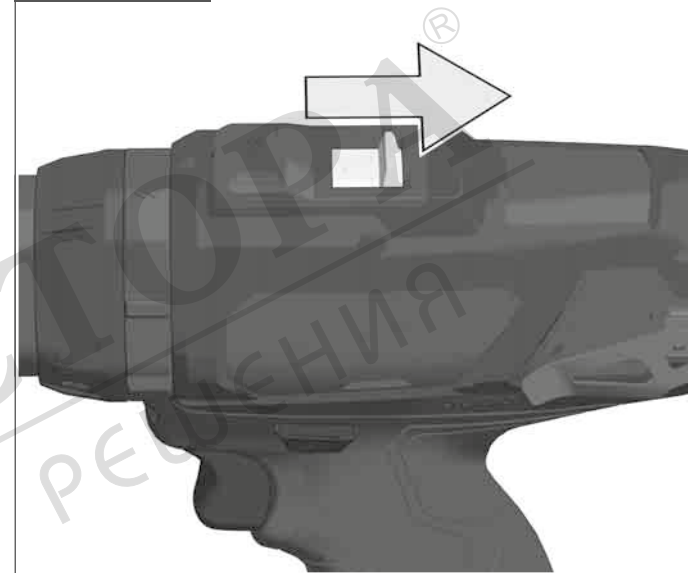
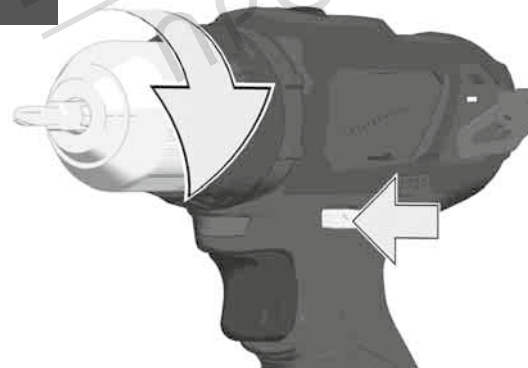
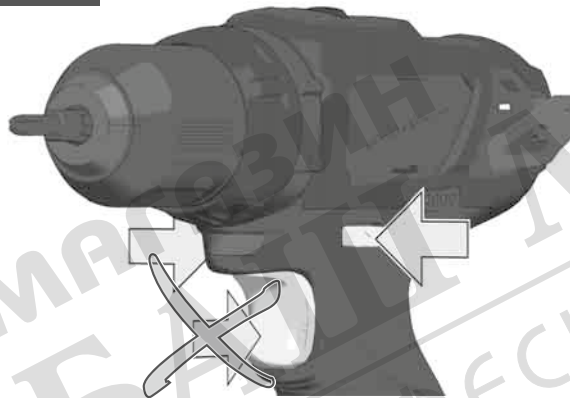

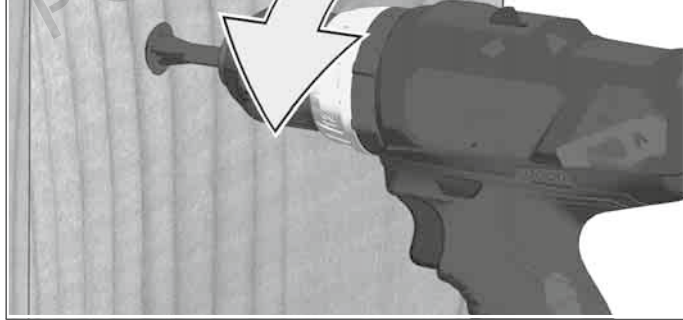
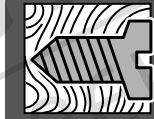
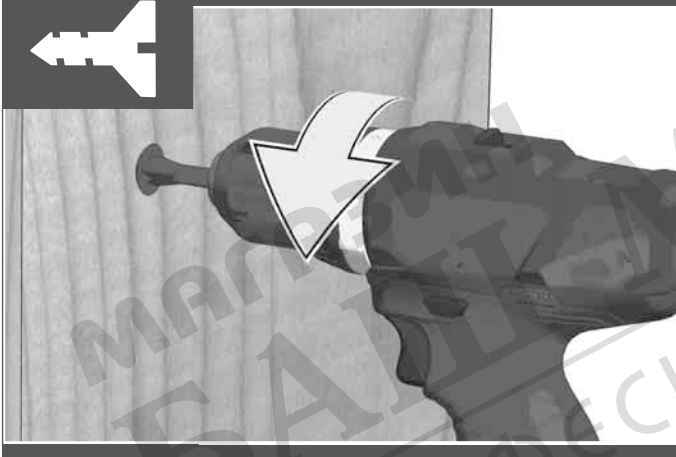
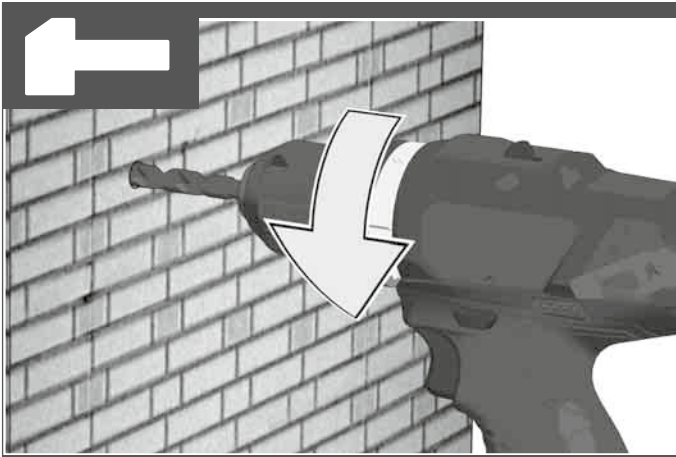

TECHNICAL DATA	CORDLESS PERCUSSION DRILL/ DRIVER	M12 BDD	M12 BPD
Production code.....	4419 16 04... ...000001-999999	4419 41 04... ...000001-999999	
Drilling capacity in steel.....	10 mm	10 mm	
Drilling capacity in wood.....	22 mm	22 mm	
Drilling capacity in brick and tile.....	10 mm	10 mm	
Wood screws (without pre-drilling).....	6 mm	6 mm	
No-load speed 1st gear.....	0-400 min <sup>-1</sup>	0-400 min <sup>-1</sup>	
No-load speed 2nd gear.....	0-1500 min <sup>-1</sup>	0-1500 min <sup>-1</sup>	
Percussion rate 1st gear.....	6000 min <sup>-1</sup>	6000 min <sup>-1</sup>	
Percussion rate 2nd gear.....	22500 min <sup>-1</sup>	22500 min <sup>-1</sup>	
Torque max (Li-Ion Battery 2.0 Ah) *1.....	30 Nm	30 Nm	
Torque max (Li-Ion Battery 4.0 Ah) *1.....	38 Nm	38 Nm	
Battery voltage.....	12 V	12 V	
Drill chuck range.....	1,5-10 mm	1,5-10 mm	
Weight according EPTA-Procedure 01/2014 (2,0 Ah).....	1,18 kg	1,24 kg	
Weight according EPTA-Procedure 01/2014 (4,0 Ah).....	1,4 kg	1,46 kg	
Recommended ambient operating temperature.....	-18°C ... +50 °C		
Recommended battery types.....	M12B..		
Recommended charger.....	M12-18 C; M12-18 FC; M12-18 AC; M12 C4; C12 C		

#### Noise/vibration information

Measured values determined according to EN 62841.

Typically, the A-weighted noise levels of the tool are:

Sound pressure level (Uncertainty K=3dB(A)).....	85 dB (A)	85 dB (A)
Sound power level (Uncertainty K=3dB(A)).....	96 dB (A)	96 dB (A)

#### Wear ear protectors!

Total vibration values (vector sum in the three axes) determined according to EN 62841.

Vibration emission value a <sub>w</sub>		
Percussion drilling into concrete.....	7,9 m/s <sup>2</sup>	
Uncertainty K=.....	1,5 m/s <sup>2</sup>	
Drilling into metal.....	1,5 m/s <sup>2</sup>	
Uncertainty K=.....	1,5 m/s <sup>2</sup>	
Screwing.....	0,4 m/s <sup>2</sup>	
Uncertainty K=.....	1,5 m/s <sup>2</sup>	

\*1 Measured according to Milwaukee Standard N 877318

#### WARNING

The vibration and noise emission level given in this information sheet has been measured in accordance with a standardized test given in EN 62841 and may be used to compare one tool with another. It may be used for a preliminary assessment of exposure.

The declared vibration and noise emission level represents the main applications of the tool. However if the tool is used for different applications, with different accessories or poorly maintained, the vibration and noise emission may differ. This may significantly increase the exposure level over the total working period.

An estimation of the level of exposure to vibration and noise should also take into account the times when the tool is switched off or when it is running but not actually doing the job. This may significantly reduce the exposure level over the total working period.

Identify additional safety measures to protect the operator from the effects of vibration and/or noise such as: maintain the tool and the accessories, keep the hands warm, organization of work patterns.

**⚠ WARNING** Read all safety warnings, instructions, illustrations and specifications provided with this power tool. Failure to follow all instructions listed below may result in electric shock, fire and/or serious injury.  
Save all warnings and instructions for future reference.

#### ⚠ DRILL SAFETY WARNINGS

##### Safety instructions for all operations

Hold the power tool by insulated gripping surfaces, when performing an operation where the cutting accessory or fasteners may contact hidden wiring.

Cutting accessory or fasteners contacting a "live" wire may make exposed metal parts of the power tool "live" and could give the operator an electric shock.

Wear ear protectors when impact drilling. Exposure to noise can cause hearing loss.

##### Safety instructions when using long drill bits

Never operate at higher speed than the maximum speed rated of the drill bit. At higher speeds, the bit is likely to bend if allowed to rotate freely without contacting the workpiece, resulting in the personal injury.

Always start drilling at low speed and with the bit tip in contact with the workpiece. At higher speeds, the bit is likely to bend if allowed to rotate freely without contacting the workpiece, resulting in the personal injury.

Apply pressure only in direct line with the bit and do not apply excessive pressure. Bits can bend causing breakage or loss of control, resulting in personal injury.

#### ADDITIONAL SAFETY AND WORKING INSTRUCTIONS

Use protective equipment. Always wear safety glasses when working with the machine. The use of protective clothing is recommended, such as dust mask, protective gloves, sturdy non-slip footwear, helmet and ear defenders.

The dust produced when using this tool may be harmful to health. Do not inhale the dust. Wear a suitable dust protection mask.

Do not machine any materials that present a danger to health (e.g. asbestos).

Switch the device off immediately if the insertion tool stalls! Do not switch the device on again while the insertion tool is stalled, as doing so could trigger a sudden recoil with a high reactive force. Determine why the insertion tool stalled and rectify this, paying heed to the safety instructions.

The possible causes may be:

- it is tilted in the workpiece to be machined
- it has pierced through the material to be machined
- the power tool is overloaded

Do not reach into the machine while it is running.

The insertion tool may become hot during use.

**WARNING!** Danger of burns

- when changing tools
- when setting the device down

Chips and splinters must not be removed while the machine is running.

When working in walls ceiling, or floor, take care to avoid electric cables and gas or waterpipes.

Clamp your workpiece with a clamping device. Unclamped workpieces can cause severe injury and damage.

Remove the battery pack before starting any work on the machine.

Do not dispose of used battery packs in the household refuse or by burning them. Milwaukee Distributors offer to retrieve old batteries to protect our environment.

Do not store the battery pack together with metal objects (short circuit risk).

Use only System M 12 chargers for charging System M 12 battery packs. Do not use battery packs from other systems.

Never break open battery packs and chargers and store only in dry rooms. Keep dry at all times.

Battery acid may leak from damaged batteries under extreme load or extreme temperatures. In case of contact with battery acid wash it off immediately with soap and water. In case of eye contact rinse thoroughly for at least 10 minutes and immediately seek medical attention.

**Warning!** To reduce the risk of fire, personal injury, and product damage due to a short circuit, never immerse your tool, battery pack or charger in fluid or allow a fluid to flow inside them. Corrosive or conductive fluids, such as seawater, certain industrial chemicals, and bleach or bleach containing products, etc., can cause a short circuit.

#### SPECIFIED CONDITIONS OF USE

**M12 BDD:** The battery drill/screwdriver may be used for drilling and screwdriving for independent use away from mains supply.

**M12 BPD:** The electronic battery percussion drill/screwdriver may be used for drilling, percussion drilling, as well as screwdriving for independent use away from mains supply.

Do not use this product in any other way as stated for normal use.

#### EC-DECLARATION OF CONFORMITY

We declare under our sole responsibility that the product described under "Technical Data" fulfills all the relevant regulations and the directives 2011/65/EU (RoHS), 2014/30/EU, 2006/42/EC, and the following harmonized standards have been used:

EN 62841-1:2015  
EN 62841-2-1:2018+A11:2019  
EN 55014-1:2017+A11:2020  
EN 55014-2:2015  
EN IEC 63000:2018

Winnenden, 2020-10-23

*Alexander Krug*  
Alexander Krug  
Managing Director

Authorized to compile the technical file

Techtronic Industries GmbH  
Max-Eyth-Straße 10  
71364 Winnenden  
Germany

#### GB-DECLARATION OF CONFORMITY

We declare as the manufacturer under our sole responsibility that the product described under "Technical Data" fulfills all the relevant provisions of the following Regulations S.I. 2008/1597 (as amended), S.I. 2016/1091 (as amended), S.I. 2012/3032 (as amended) and that the following designated standards have been used:

BS EN 62841-1:2015  
BS EN 62841-2-1:2018+A11:2019  
BS EN 55014-1:2017+A11:2020  
BS EN 55014-2:2015  
BS EN IEC 63000:2018

Winnenden, 2020-10-23

*Alexander Krug*  
Alexander Krug  
Managing Director

Authorized to compile the technical file.

Techtronic Industries GmbH  
Max-Eyth-Straße 10  
71364 Winnenden  
Germany

#### BATTERIES

Battery packs which have not been used for some time should be recharged before use.

Temperatures in excess of 50°C (122°F) reduce the performance of the battery pack. Avoid extended exposure to heat or sunshine (risk of overheating).

The contacts of chargers and battery packs must be kept clean.

For an optimum life-time, the battery packs have to be fully charged, after used.

To obtain the longest possible battery life remove the battery pack from the charger once it is fully charged.

For battery pack storage longer than 30 days:

Store the battery pack where the temperature is below 27°C and away from moisture

Store the battery packs in a 30% - 50% charged condition

Every six months of storage, charge the pack as normal.

#### BATTERY PACK PROTECTION

In extremely high torque, binding, stalling and short circuit situations that cause high current draw, the tool will vibrate for about 5 seconds, the fuel gauge will flash, and then the tool will turn OFF. To reset, release the trigger.

Under extreme circumstances, the internal temperature of the battery pack could raise too much. If this happens, the fuel gauge will flash until the battery pack cooled down. After the lights go off, the work may continue.

#### TRANSPORTING LITHIUM BATTERIES

Lithium-ion batteries are subject to the Dangerous Goods Legislation requirements.

Transportation of those batteries has to be done in accordance with local, national and international provisions and regulations.

- The user can transport the batteries by road without further requirements.
- Commercial transport of Lithium-Ion batteries by third parties is subject to Dangerous Goods regulations. Transport preparation and transport are exclusively to be carried out by appropriately trained persons and the process has to be accompanied by corresponding experts.

When transporting batteries:

- Ensure that battery contact terminals are protected and insulated to prevent short circuit.
- Ensure that battery pack is secured against movement within packaging.
- Do not transport batteries that are cracked or leak.

Check with forwarding company for further advice

#### MAINTENANCE

Use only Milwaukee accessories and spare parts. Should components need to be replaced which have not been described, please contact one of our Milwaukee service agents (see our list of guarantees/service addresses).

If needed, an exploded view of the tool can be ordered. Please state the machine type printed as well as the six-digit No. on the label and order the drawing at your local service agents or directly at: Techtronic Industries GmbH, Max-Eyth-Straße 10, 71364 Winnenden, Germany.

#### SYMBOLS

	CAUTION! WARNING! DANGER!
	Remove the battery pack before starting any work on the machine.
	Please read the instructions carefully before starting the machine.
	Do not dispose electric tools, batteries/rechargeable batteries together with household waste material. Electric tools and batteries that have reached the end of their life must be collected separately and returned to an environmentally compatible recycling facility. Check with your local authority or retailer for recycling advice and collection point.
	No-load speed
	Volts
	Direct current
	European Conformity Mark
	British Conformity Mark
	Ukraine Conformity Mark
	EurAsian Conformity Mark



МАГАЗИН  
**БАШ МАЙСТОРА**<sup>®</sup>  
ПРОФЕСИОНАЛНИ РЕШЕНИЯ

Copyright 2020

Techtronic Industries GmbH  
Max-Eyth-Str. 10  
71364 Winnenden  
Germany

+49 (0) 7195-12-0

[www.milwaukeeetool.eu](http://www.milwaukeeetool.eu)

Techtronic Industries (UK) Ltd  
Fieldhouse Lane  
Marlow Bucks SL7 1HZ  
UK



**EAC UK  
CA**

(10.20)

**4100 4144 43**