

Milwaukee[®]

Nothing but **HEAVY DUTY**.[®]



M18 FHM

Original instructions



МАГАЗИН
БАШ МАЙСТОРА[®]
ПРОФЕСИОНАЛНИ РЕШЕНИЯ

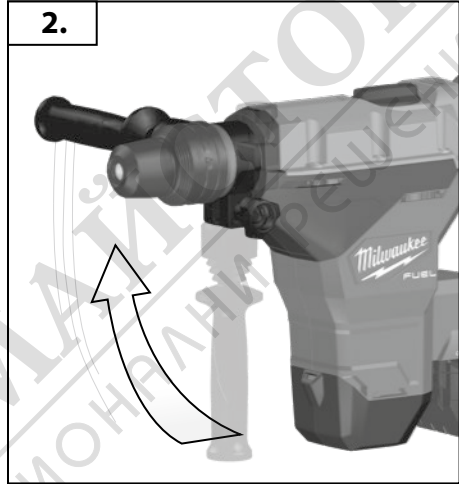
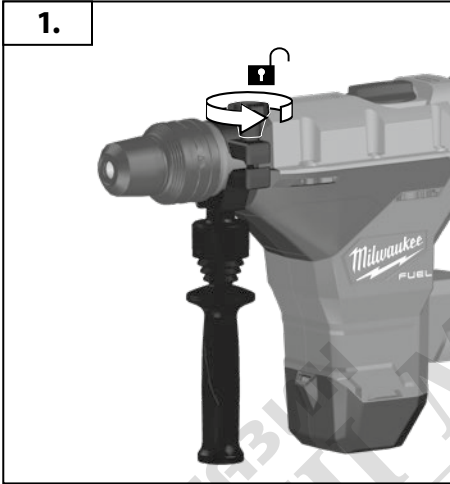
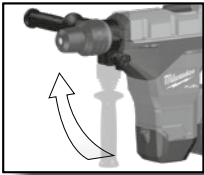

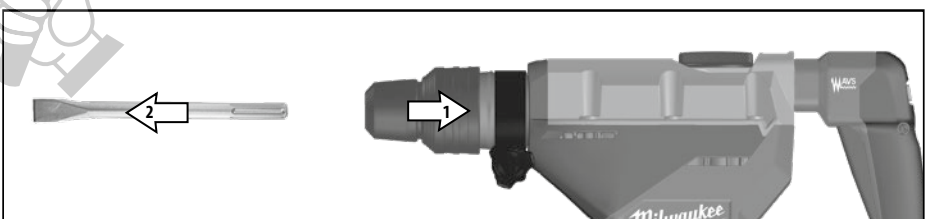
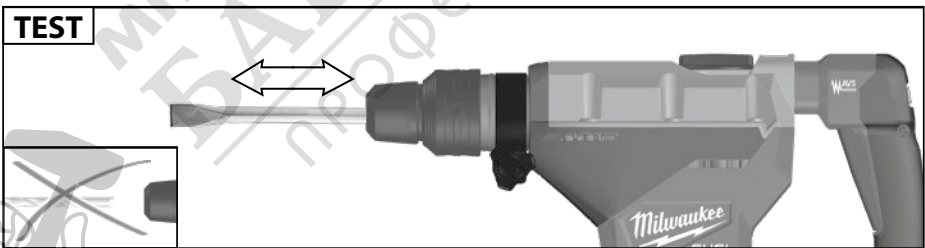
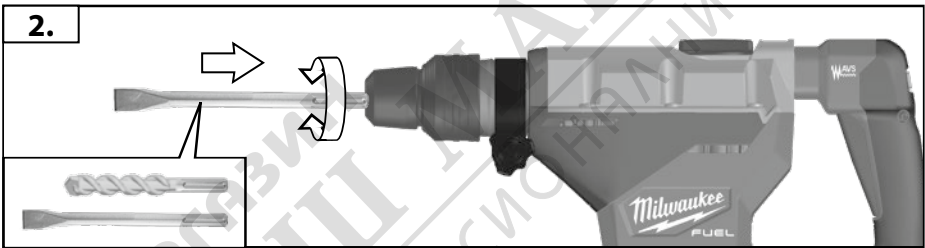
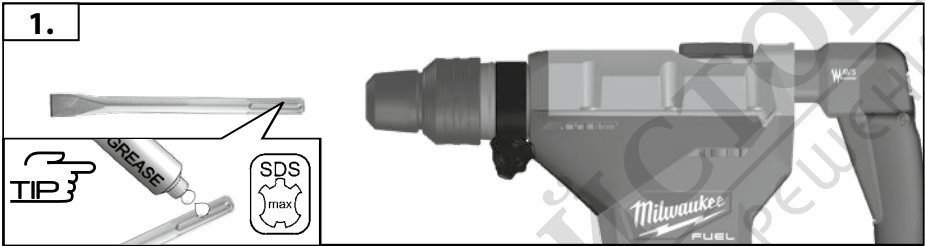
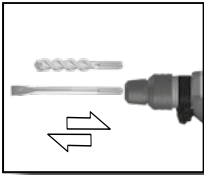

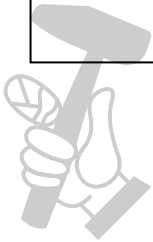
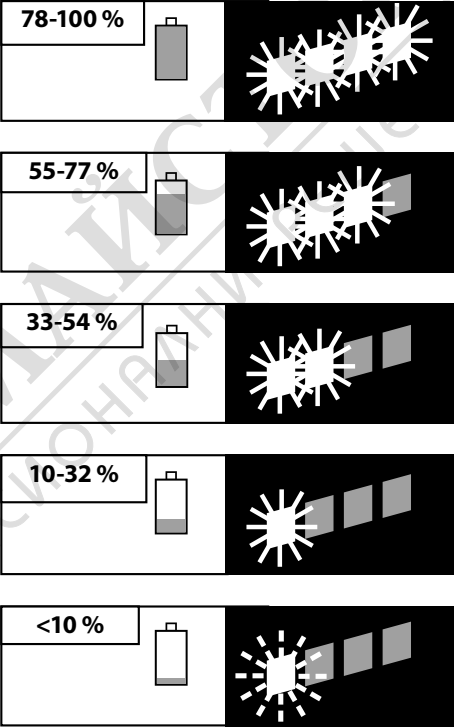
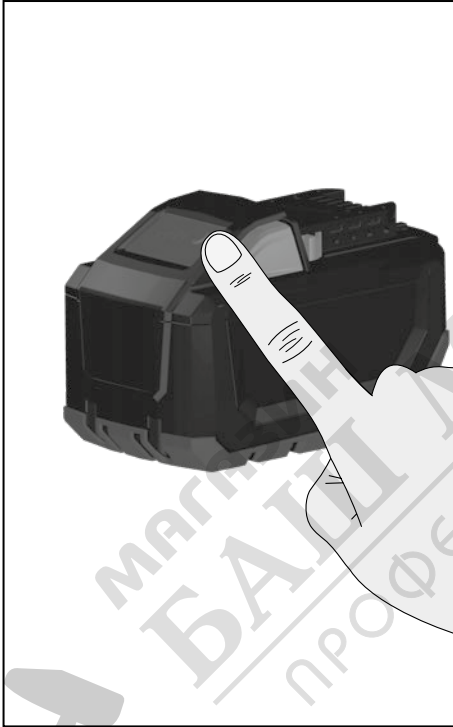

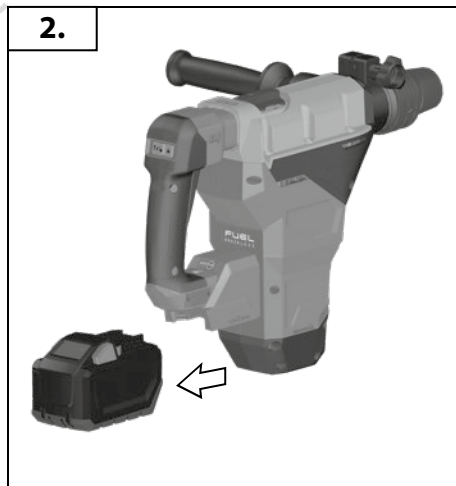
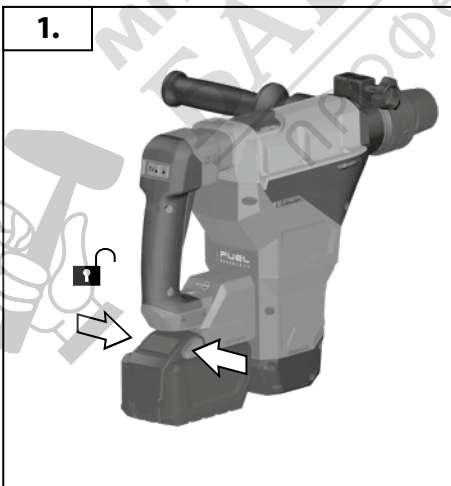
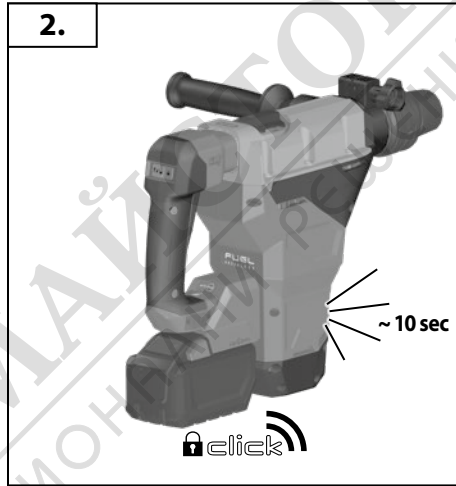
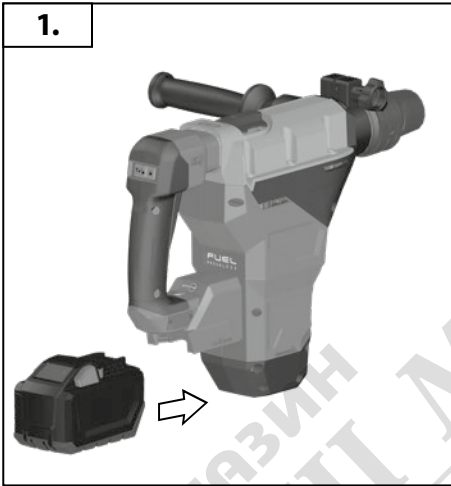



START
STOP



Insulated gripping surface

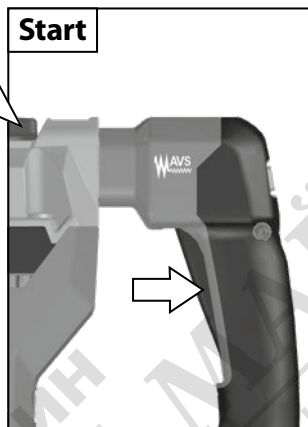
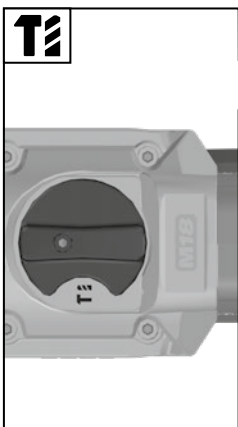

МАГАЗИН МАКЕТАТОРА
БАШ МАКЕТАТОРА
ПРОФЕСИОНАЛНИ РЕШЕНИЯ



**START
STOP**

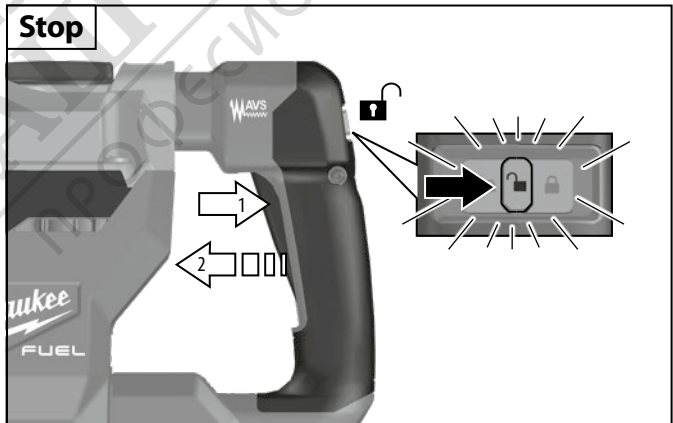
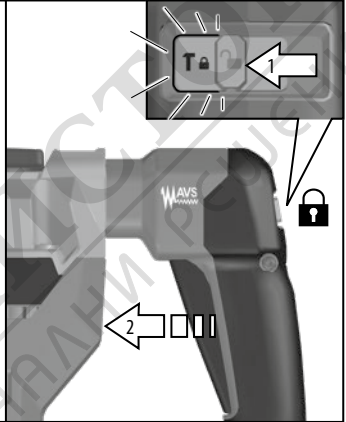
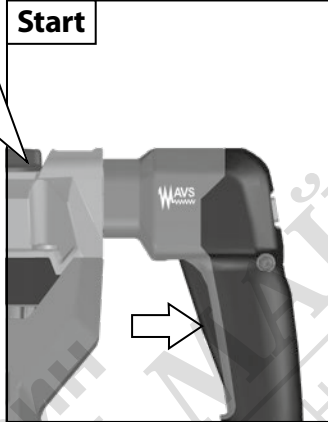
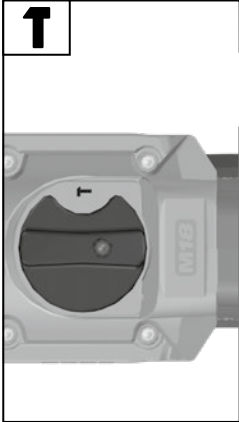

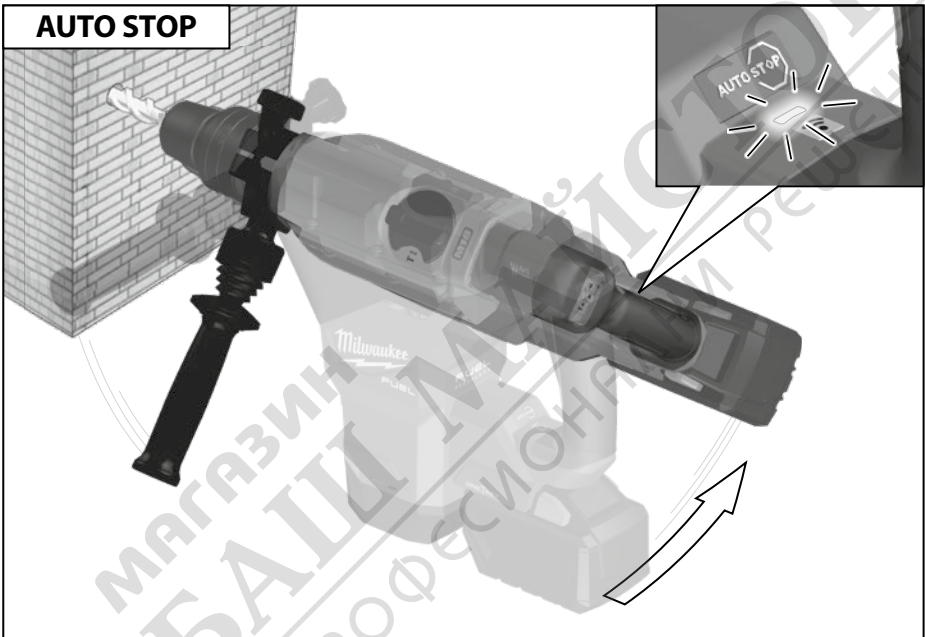

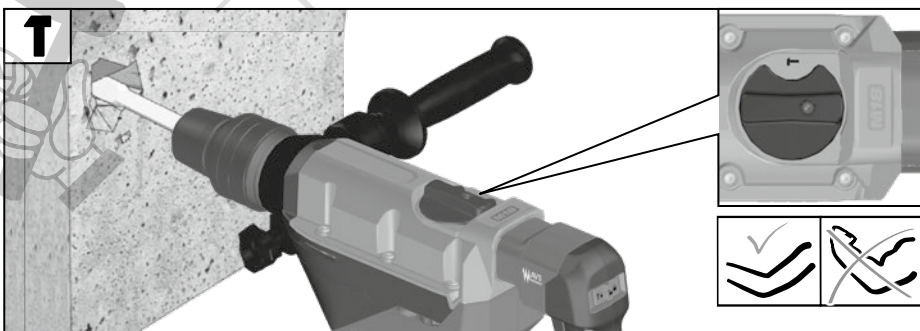
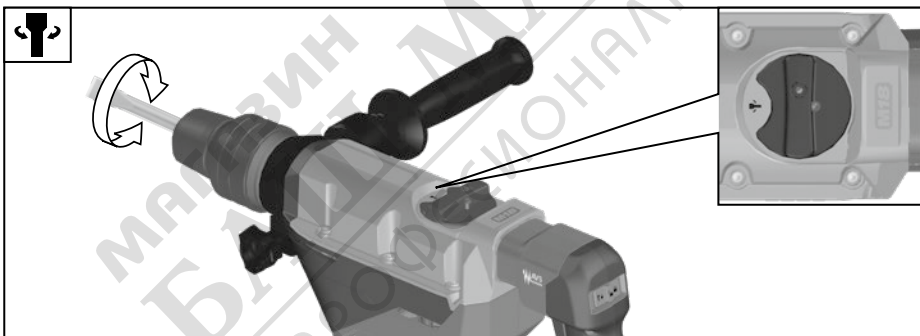
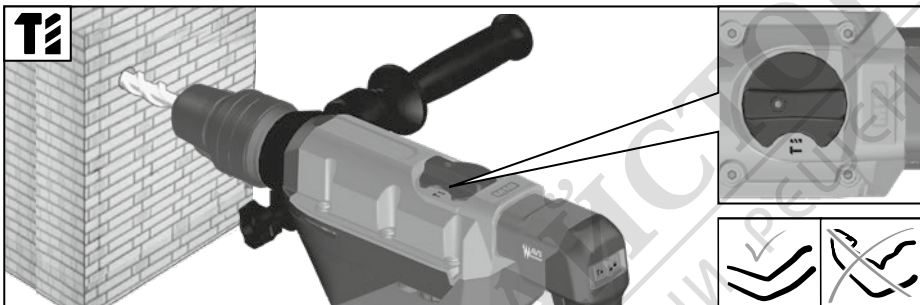
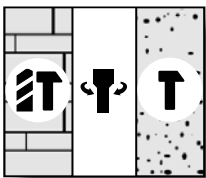

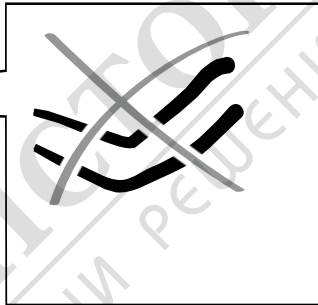
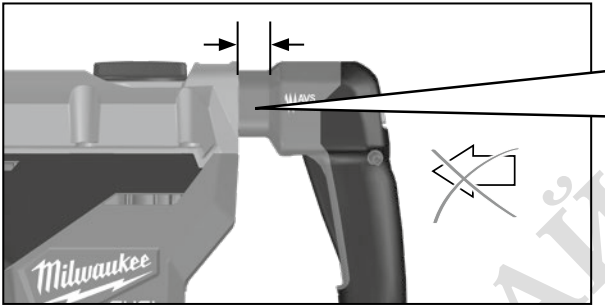

AVS

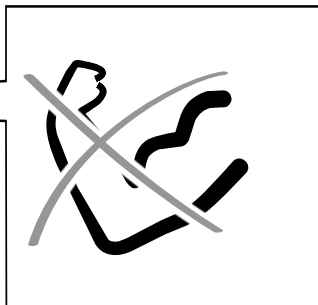
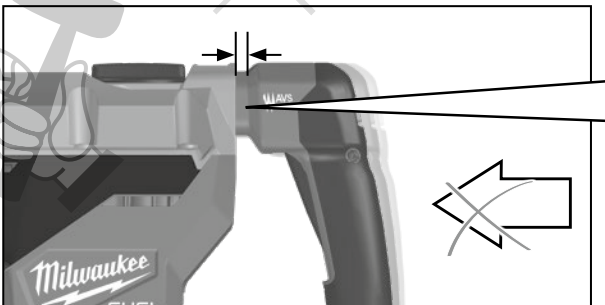
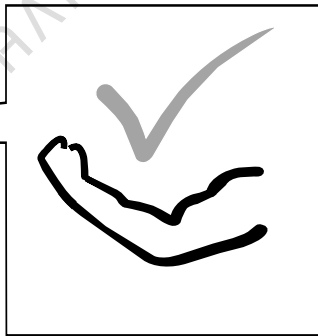
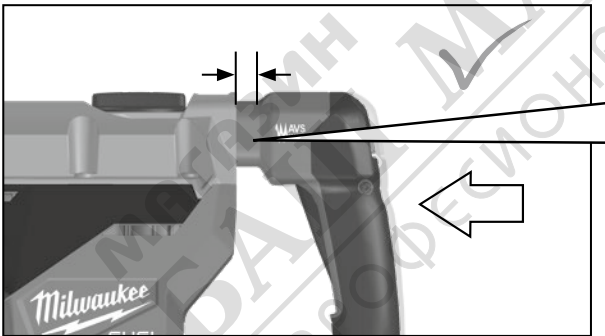

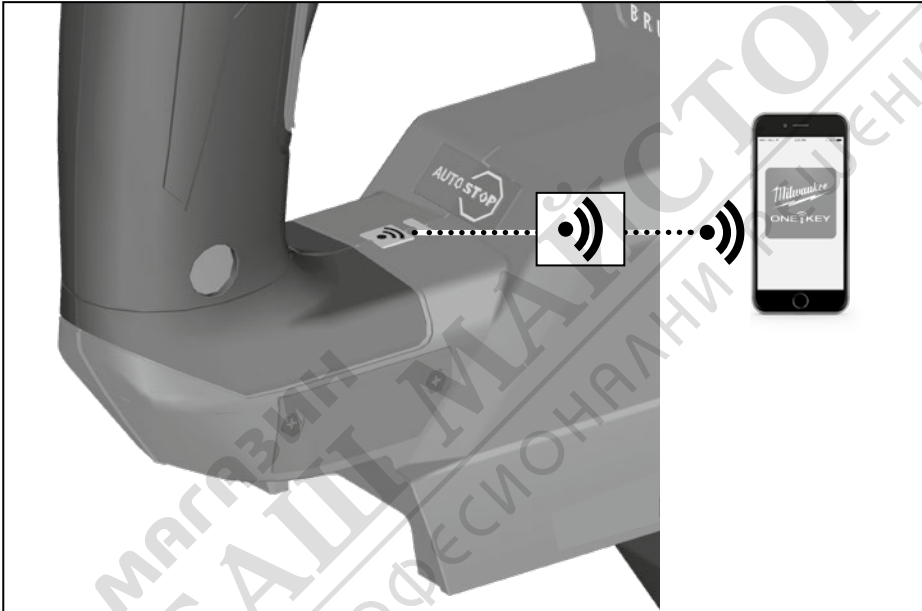

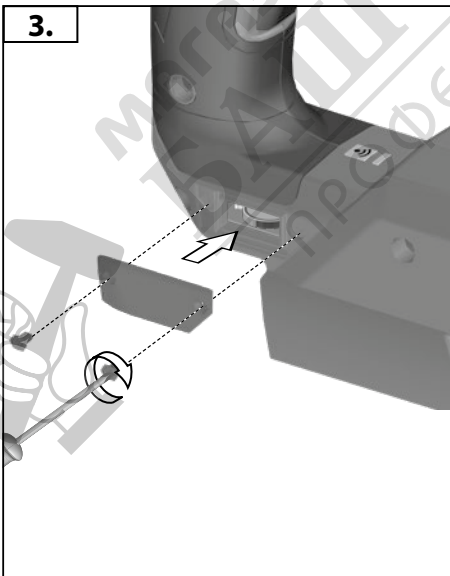
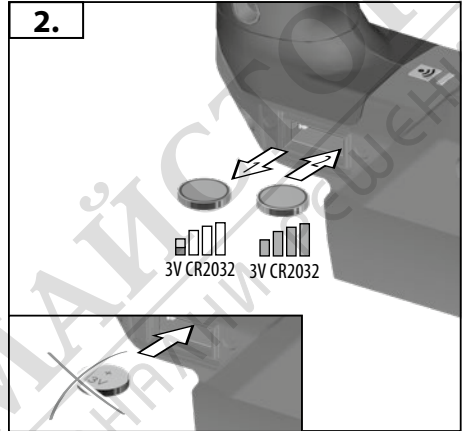
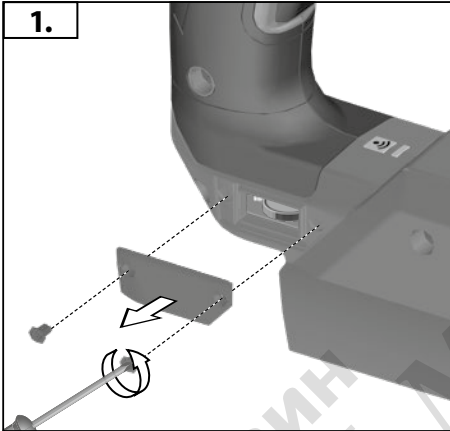

TECHNICAL DATA	M18 FHM
Cordless Rotary Hammer	
Production code	4696 96 02... ... 000001-999999
Frequency band	2402-2480 MHz
Radio-frequency power	1,8 dBm
Battery voltage	18 V
No-load speed	380 min ⁻¹
Rate of percussion under load max.	2900 min ⁻¹
Impact energy per stroke according to EPTA-Procedure 05/2009	11 J
Chuck neck diameter	66 mm
Drilling capacity in concrete	45 mm (SDS-max)
Tunnel bit in concrete, bricks and limestone	65 mm (SDS-max)
Core cutter in concrete, bricks and limestone	150 mm (SDS-max)
Weight according EPTA-Procedure 01/2014 (Li-Ion 5,0 Ah ... 12,0 Ah)	9,7 ... 10,4 kg
Recommended Ambient Operating Temperature	-18 °C ... +50 °C
Recommended battery types	M18B5 – M18HB12
Recommended charger	M12-18...
Noise information	
Measured values determined according to EN 60745. Typically, the A-weighted noise levels of the tool are	
Sound pressure level (Uncertainty K=3dB(A))	96,5 dB (A)
Sound power level (Uncertainty K=3dB(A))	107,5 dB (A)
Wear ear protectors!	
Vibration information	
Vibration total values (triaxial vector sum) determined according to EN 60745	
Hammer-drilling into concrete	
Vibration emission value $a_{h,HD}$	9,4 m/s ²
Uncertainty K=	1,5 m/s ²
Chiselling:	
Vibration emission value $a_{h,Cheq}$	9,4 m/s ²
Uncertainty K=	1,5 m/s ²



WARNING!

The vibration emission level given in this information sheet has been measured in accordance with a standardised test given in EN 60745 and may be used to compare one tool with another. It may be used for a preliminary assessment of exposure.

The declared vibration emission level represents the main applications of the tool. However if the tool is used for different applications, with different accessories or poorly maintained, the vibration emission may differ. This may significantly increase the exposure level over the total working period.

An estimation of the level of exposure to vibration should also take into account the times when the tool is switched off or when it is running but not actually doing the job. This may significantly reduce the exposure level over the total working period.

Identify additional safety measures to protect the operator from the effects of vibration such as maintain the tool and the accessories, keep the hands warm, organisation of work patterns.

WARNING! Read all safety warnings and all instructions. Failure to follow the warnings and instructions may result in electric shock, fire and/or serious injury. Save all warnings and instructions for future reference.

HAMMER SAFETY WARNINGS

Wear ear protectors. Exposure to noise can cause hearing loss. **Use auxiliary handle(s), if supplied with the tool.** Loss of control can cause personal injury.

Hold the power tool by insulated gripping surfaces, when performing an operation where the cutting accessory may contact hidden wiring. Cutting accessory contacting a "live" wire may make exposed metal parts of the power tool "live" and could give the operator an electric shock.

Additional Safety and Working Instructions

Use protective equipment. Always wear safety glasses when working with the machine. The use of protective clothing is recommended, such as dust mask, protective gloves, sturdy non-slip footwear, helmet and ear defenders.

The dust produced when using this tool may be harmful to health. Do not inhale the dust. Use a dust absorption system and wear a suitable dust protection mask. Remove deposited dust thoroughly, e.g. with a vacuum cleaner.

Do not machine any materials that present a danger to health (e.g. asbestos).

When working in walls ceiling, or floor, take care to avoid electric cables and gas or waterpipes.

Switch the device off immediately if the insertion tool stalls! Do not switch the device on again while the insertion tool is stalled, as doing so could trigger a sudden recoil with a high reactive force. Determine why the insertion tool stalled and rectify this, paying heed to the safety instructions.

Possible causes can be

- it is tilted in the workpiece to be machined
- breakage of the material to be used
- the power tool is overloaded

Do not reach into the machine while it is running.

The insertion tool may become hot during use.

WARNING! Danger of burns

- when changing tools
- when setting the device down

Chips and splinters must not be removed while the machine is running.

Clamp your workpiece with a clamping device. Unclamped workpieces can cause severe injury and damage.

Remove the battery pack before starting any work on the appliance.

WARNING! To reduce the risk of fire, personal injury, and product damage due to a short circuit, never immerse your tool, battery pack or charger in fluid or allow a fluid to flow inside them. Corrosive or conductive fluids, such as seawater, certain industrial chemicals, and bleach or bleach containing products, etc., Can cause a short circuit.

WARNING



This device contains a button-type/coin cell lithium battery. A new or used battery can cause severe internal burns and lead to death in as little as 2 hours if swallowed or if it enters the body. Always secure the cover on the battery compartment. If it does not close securely, stop the device, remove the battery and keep it out of reach of children. If you believe that someone has swallowed the battery or that it has otherwise entered the body, seek immediate medical attention.

OPERATION

Cold Starting

If this tool is stored for a long period of time or at cold temperatures, it may not hammer initially because the lubrication has become stiff.

To warm up the tool

1. Insert and lock a bit or chisel into the tool.
2. Pull the trigger and apply force to the bit or chisel against a concrete or wood surface for a few seconds. Release the trigger.
3. Repeat until the tool starts hammering. The colder the tool is, the longer it will take to warm up.

ONE-KEY™

To learn more about the ONE-KEY functionality of this tool, please refer to the Quick Start guide included with this product or go to <http://www.milwaukeeetool.com/one-key>

To download the ONE-KEY app, visit the App Store or Google Play from your smart device. We considered the result to be within our minimum acceptable performance level according to EN 301489-1/EN 301489-17. And we will give the operation guidance to the customer in user manual.

BATTERIES

Battery packs which have not been used for some time should be recharged before use.

Temperatures in excess of 50 °C (122°F) reduce the performance of the battery pack. Avoid extended exposure to heat or sunshine (risk of overheating).

but

For an optimum life-time, the battery packs have to be fully charged, after use.

To obtain the longest possible battery life remove the battery pack from the charger once it is fully charged. For battery pack storage longer than 30 days Store the battery pack where the temperature is below 27°C and away from moisture Store the battery packs in a 30% - 50% charged condition Every six months of storage, charge the pack as normal.

Do not dispose of used battery packs in the household refuse or by burning them. Milwaukee Distributors offer to retrieve old batteries to protect our environment.

Do not store the battery pack together with metal objects (short circuit risk).

Use only System M18 chargers for charging System M18 battery packs. Do not use battery packs from other systems.

Never break open battery packs and chargers and store only in dry rooms. Keep dry at all times.

Battery acid may leak from damaged batteries under extreme load or extreme temperatures. In case of contact with battery acid wash it off immediately with soap and water. In case of eye contact rinse thoroughly for at least 10 minutes and immediately seek medical attention.

No metal parts must be allowed to enter the battery section of the charger (short circuit risk).

BATTERY PACK PROTECTION

In extremely high torque, binding, stalling and short circuit situations that cause high current draw, the tool will stop for about 2 seconds and then the tool will turn OFF. To reset, remove the battery pack from the tool and replace it.

Under extreme circumstances, the internal temperature of the battery pack could raise too much. If this happens, the fuel gauge will flash until the battery pack cooled down. After the lights go off, the work may continue. Place the battery on the charger to charge and reset it.

TRANSPORTING LITHIUM BATTERIES

Lithium-ion batteries are subject to the Dangerous Goods Legislation requirements.

Transportation of those batteries has to be done in accordance with local, national and international provisions and regulations.

The user can transport the batteries by road without further requirements.

Commercial transport of Lithium-Ion batteries by third parties is subject to Dangerous Goods regulations. Transport preparation and transport are exclusively to be carried out by appropriately trained persons and the process has to be accompanied by corresponding experts.

When transporting batteries

Ensure that battery contact terminals are protected and insulated to prevent short circuit.

Ensure that battery pack is secured against movement within packaging.

Do not transport batteries that are cracked or leak.

Check with forwarding company for further advice



SPECIFIED CONDITIONS OF USE

The pneumatic hammer can be universally used for hammer drilling and chiselling in stone and concrete.

MAINTENANCE

Remove the battery pack before starting any work on the appliance.

The ventilation slots of the machine must be kept clear at all times.

Use only Milwaukee accessories and Milwaukee spare parts. Should components need to be replaced which have not been described, please contact one of our Milwaukee service agents (see our list of guarantee/service addresses).

If needed, an exploded view of the tool can be ordered. Please state the Article No. as well as the machine type printed on the label and order the drawing at your local service agents or directly at Techtronic Industries GmbH, Max-Eyth-Straße 10, 71364 Winnenden, Germany.

EC-DECLARATION OF CONFORMITY

We declare under our sole responsibility that the product described under "Technical Data" fulfills all the relevant provisions of the directives

2011/65/EU (RoHS)

2006/42/EC

2014/53/EU

and the following harmonized standards have been used.

EN 60745-1:2009 + A11:2010

EN 60745-2-6:2010

EN 55014-1:2017+A11:2020

EN 55014-2:2015

EN IEC 63000:2018

EN 301 489-1 V2.2.3

EN 301 489-17 V3.1.1

EN 300 328 V2.2.2

EN 62479:2010



Winnenden, 2020-11-30

Alexander Krug / Managing Director
Authorized to compile the technical file

Techtronic Industries GmbH
Max-Eyth-Straße 10, 71364 Winnenden, Germany

GB-DECLARATION OF CONFORMITY

We declare as the manufacturer under our sole responsibility that the product described under „Technical Data“ fulfills all the relevant provisions of the following Regulations S.I. 2012/3032 (as amended), S.I. 2008/1597 (as amended), S.I. 2017/1206 (as amended) and that the following designated standards have been used:

BS EN 60745-1:2009 + A11:2010

BS EN 60745-2-6:2010

BS EN 55014-1:2017+A11:2020

BS EN 55014-2:2015

BS EN IEC 63000:2018

EN 301 489-1 V2.2.3

EN 301 489-17 V3.1.1

EN 300 328 V2.2.2

BS EN 62479:2010

Winnenden, 2020-11-30

Alexander Krug / Managing Director
Authorized to compile the technical file

Techtronic Industries GmbH
Max-Eyth-Straße 10, 71364 Winnenden, Germany

SYMBOLS



CAUTION! WARNING! DANGER!



Remove the battery pack before starting any work on the appliance.



Please read the instructions carefully before starting the machine.



Accessory - Not included in standard equipment, available as an accessory.



ANTI Vibration System



Do not use force.



Always wear goggles when using the machine.



Wear ear protectors.



This device contains a button-type/coin cell lithium battery.



Do not dispose electric tools, batteries/rechargeable batteries together with household waste material. Electric tools and batteries that have reached the end of their life must be collected separately and returned to an environmentally compatible recycling facility. Check with your local authority or retailer for recycling advice and collection point.

n_0

No-load speed

V

Voltage



Direct Current



European Conformity Mark



British Conformity Mark



Ukraine Conformity Mark

001



EurAsian Conformity Mark



МАГАЗИН
БАШ МАЙСТОРА®
ПРОФЕСИОНАЛНИ РЕШЕНИЯ



Copyright 2021
Techtronic Industries GmbH
Max-Eyth-Straße 10
71364 Winnenden
Germany
+49 (0) 7195-12-0
www.milwaukeeetool.eu

Techtronic Industries (UK) Ltd
Fieldhouse Lane
Marlow Bucks SL7 1HZ
UK



**EAC UK
CA**

(01.21)

4100 4250 97