

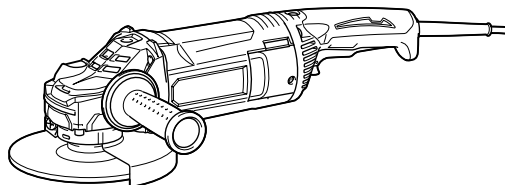

<b>EN</b>	Angle Grinder	INSTRUCTION MANUAL	7
<b>FR</b>	Meuleuse d'Angle	MANUEL D'INSTRUCTIONS	20
<b>DE</b>	Winkelschleifer	BETRIEBSANLEITUNG	34
<b>IT</b>	Smerigliatrice angolare	ISTRUZIONI PER L'USO	49
<b>NL</b>	Haakse slijpmachine	GEBRUIKSAANWIJZING	64
<b>ES</b>	Esmeriladora Angular	MANUAL DE INSTRUCCIONES	78
<b>PT</b>	Esmerilhadeira Angular	MANUAL DE INSTRUÇÕES	92
<b>DA</b>	Vinkelsliber	BRUGSANVISNING	106
<b>EL</b>	Γωνιακός λειαντήρας	ΕΓΧΕΙΡΙΔΙΟ ΟΔΗΓΙΩΝ	119
<b>TR</b>	Taşlama Makinası	KULLANMA KILAVUZU	134

**GA7080**  
**GA7081**  
**GA7082**  
**GA9080**  
**GA9081**  
**GA9082**

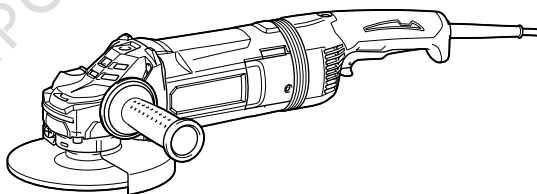

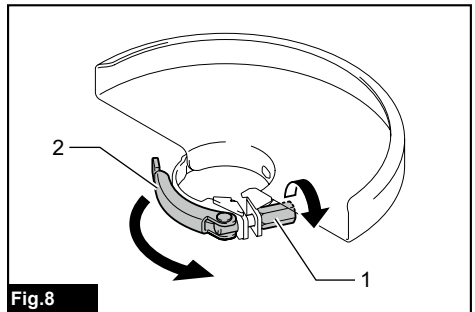
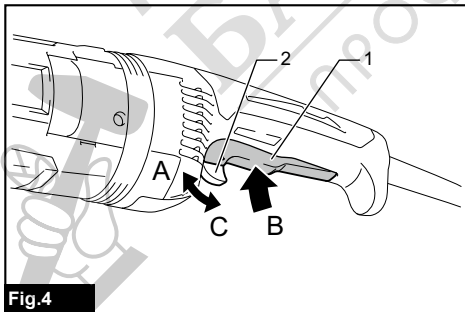
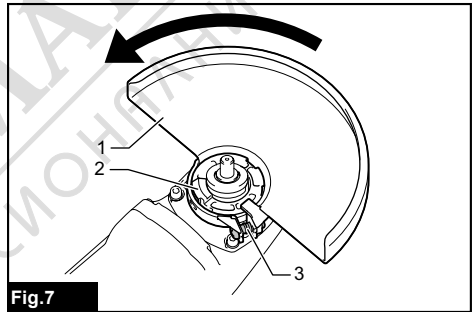
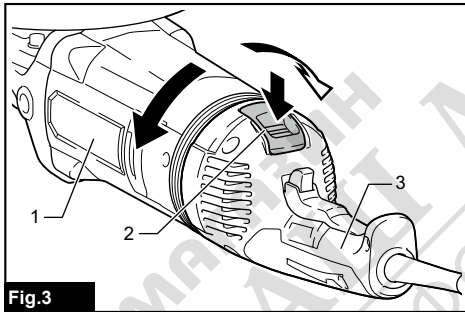
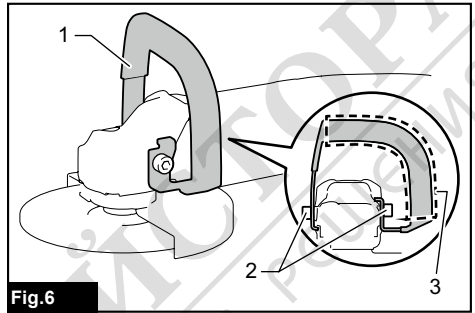
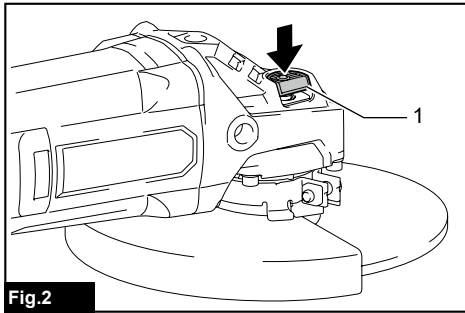
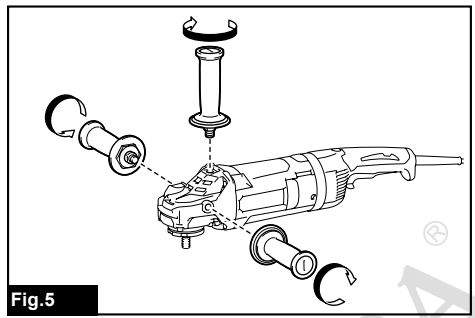
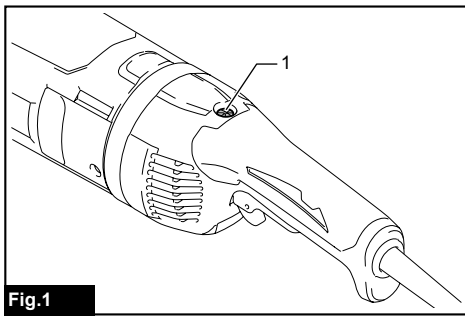

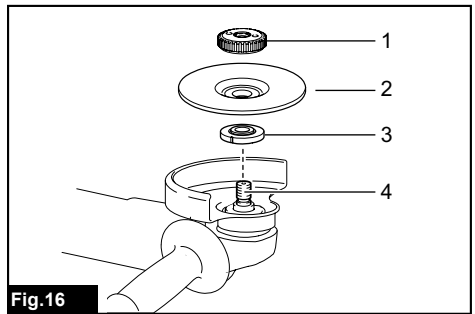
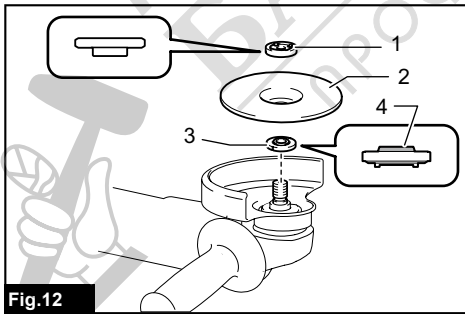
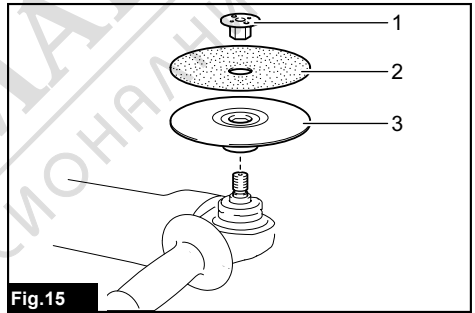
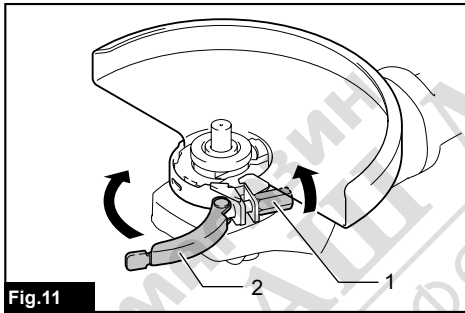
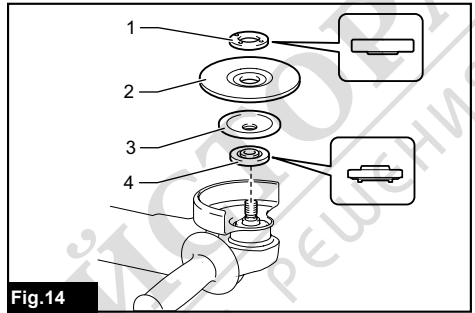
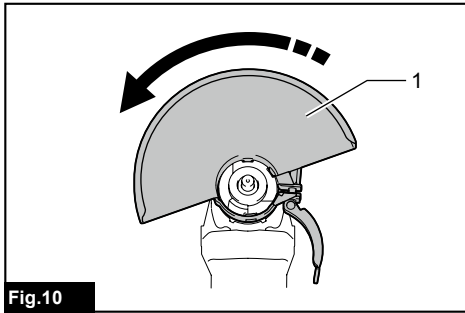
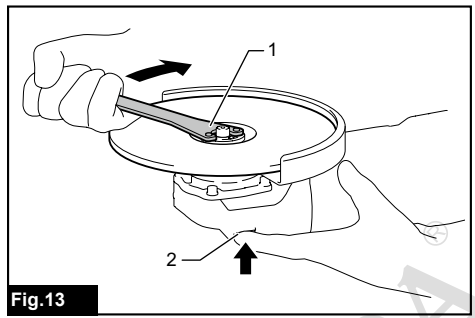
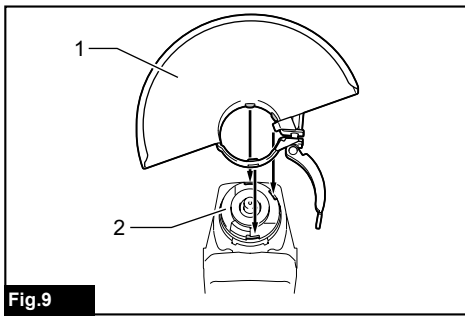

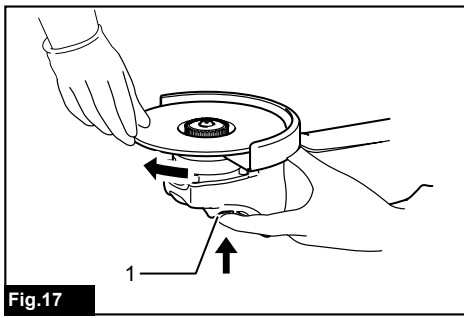

Fig.17

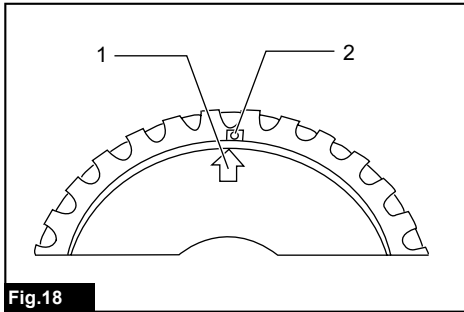

Fig.18

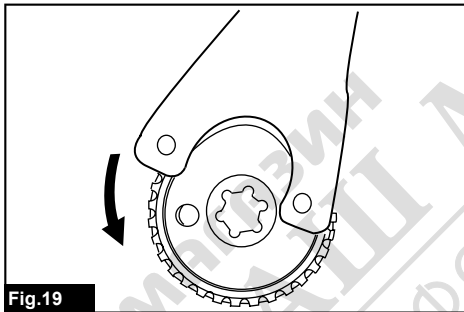

Fig.19

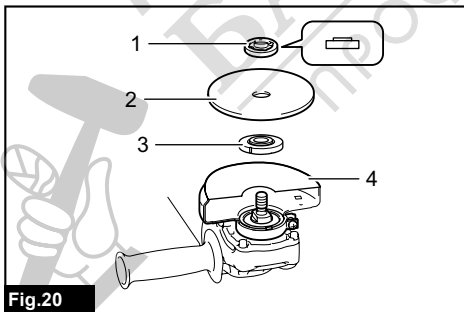

Fig.20

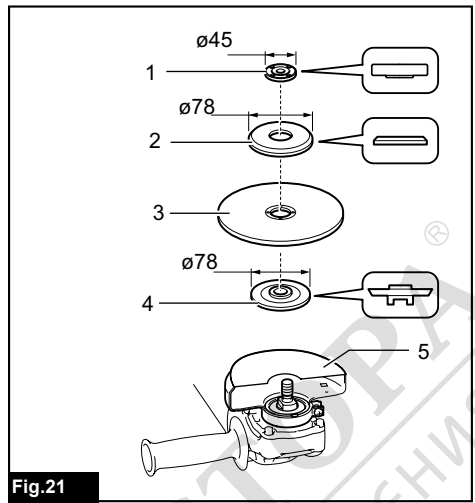

Fig.21

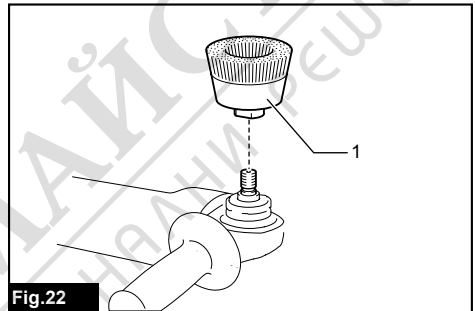

Fig.22

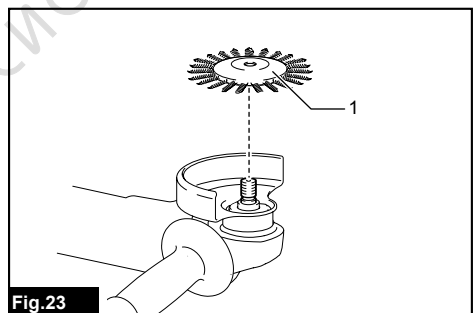

Fig.23

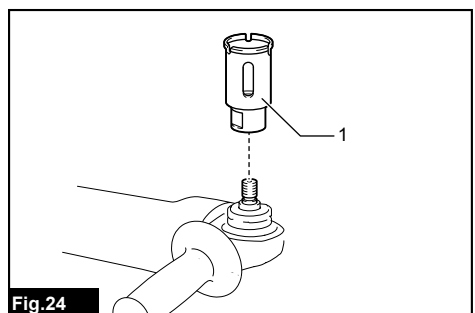

Fig.24

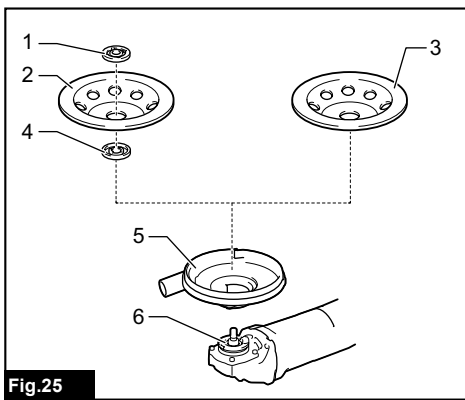

Fig.25

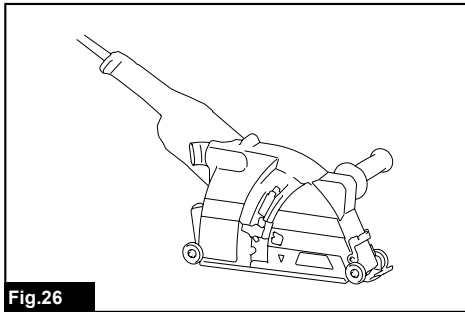

Fig.26

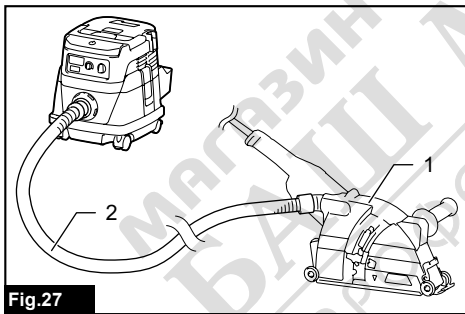

Fig.27

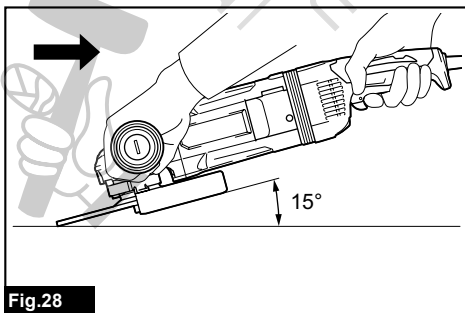

Fig.28

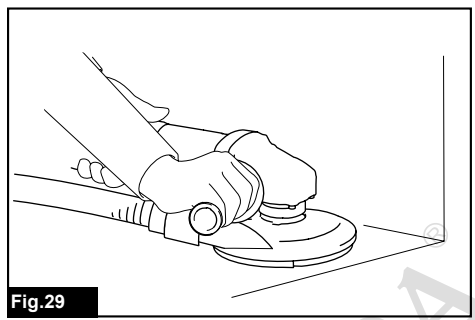

Fig.29

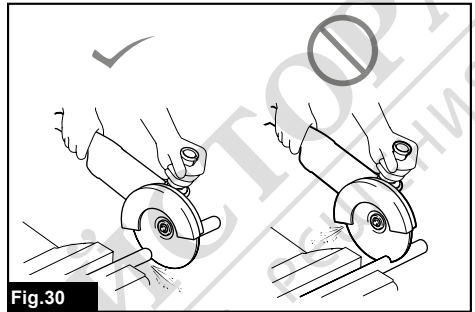

Fig.30

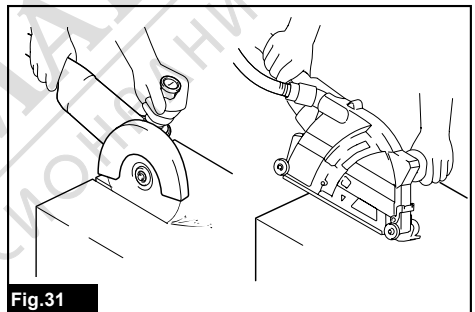

Fig.31

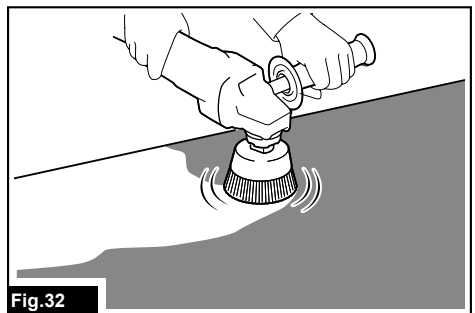
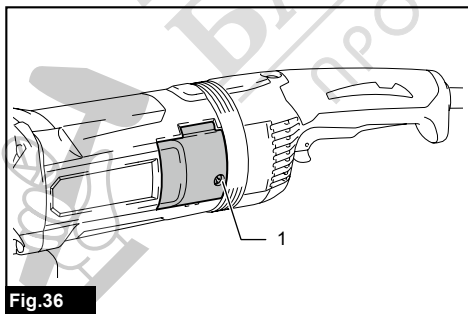
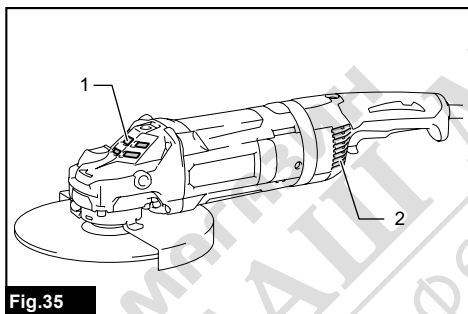
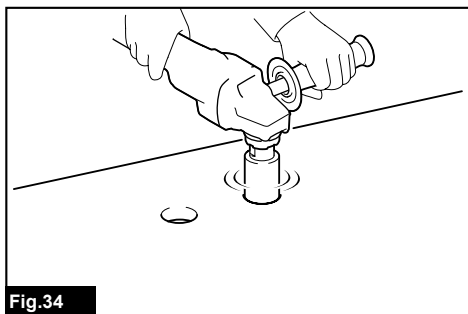
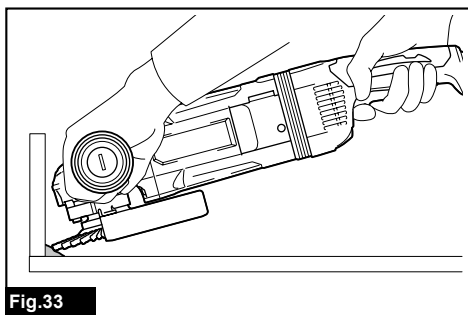

Fig.32







# SPECIFICATIONS

Model:		GA7080	GA7081	GA7082	GA9080	GA9081	GA9082
Applicable grinding wheel	Max. wheel diameter	180 mm			230 mm		
	Max. wheel thickness	7.2 mm			6.5 mm		
Applicable cut-off wheel	Max. wheel diameter	180 mm			230 mm		
	Max. wheel thickness	4.0 mm			3.2 mm		
Applicable wire wheel brush	Max. wheel diameter	150 mm			175 mm		
	Max. wheel thickness	20 mm					
Spindle thread		M14 or M16 or 5/8" (country specific)					
Max. spindle length		26 mm					
No load speed (n <sub>0</sub> ) / Rated speed (n)		8,500 min <sup>-1</sup>			6,600 min <sup>-1</sup>		
Overall length		509 mm	461 mm		509 mm	461 mm	
Net weight		6.3 - 6.8 kg	6.1 - 6.6 kg	6.0 - 6.5 kg	6.5 - 8.6 kg	6.3 - 8.4 kg	6.2 - 8.3 kg
Safety class		□/II					

- Due to our continuing program of research and development, the specifications herein are subject to change without notice.
- Specifications may differ from country to country.
- The weight may differ depending on the attachment(s). The lightest and heaviest combinations, according to EPTA-Procedure 01/2014, are shown in the table.

## Symbols

The followings show the symbols which may be used for the equipment. Be sure that you understand their meaning before use.

	Read instruction manual.
	Wear safety glasses.
	Always operate with two hands.
	Do not use the wheel guard for cut-off operations.
	DOUBLE INSULATION



Only for EU countries

Due to the presence of hazardous components in the equipment, used electrical and electronic equipment may have a negative impact on the environment and human health.

Do not dispose of electrical and electronic appliances with household waste!

In accordance with the European Directive on waste electrical and electronic equipment and its adaptation to national law, used electrical and electronic equipment should be collected separately and delivered to a separate collection point for municipal waste, operating in accordance with the environmental protection regulations.

This is indicated by the symbol of the crossed-out wheeled bin placed on the equipment.

## Intended use

The tool is intended for grinding, sanding, wire brushing, hole cutting and cutting of metal and stone materials without the use of water.

## Power supply

The tool should be connected only to a power supply of the same voltage as indicated on the nameplate, and can only be operated on single-phase AC supply. They are double-insulated and can, therefore, also be used from sockets without earth wire.

## For public low-voltage distribution systems of between 220 V and 250 V

### Only for model GA7082 / GA9082

Switching operations of electric apparatus cause voltage fluctuations. The operation of this device under unfavorable mains conditions can have adverse effects to the operation of other equipment. With a mains impedance equal or less than 0.20 Ohms it can be presumed that there will be no negative effects. The mains socket used for this device must be protected with a fuse or protective circuit breaker having slow tripping characteristics.

## Noise

The typical A-weighted noise level determined according to EN62841-2-3:

Model	Sound pressure level ( $L_{pA}$ ) : (dB(A))	Sound power level ( $L_{WA}$ ) : (dB(A))	Uncertainty (K) : (dB(A))
GA7080	94	102	3
GA7081	94	102	3
GA7082	94	102	3
GA9080	95	103	3
GA9081	95	103	3
GA9082	95	103	3

**NOTE:** The declared noise emission value(s) has been measured in accordance with a standard test method and may be used for comparing one tool with another.

**NOTE:** The declared noise emission value(s) may also be used in a preliminary assessment of exposure.

**⚠ WARNING:** Wear ear protection.

**⚠ WARNING:** The noise emission during actual use of the power tool can differ from the declared value(s) depending on the ways in which the tool is used especially what kind of workpiece is processed.

**⚠ WARNING:** Be sure to identify safety measures to protect the operator that are based on an estimation of exposure in the actual conditions of use (taking account of all parts of the operating cycle such as the times when the tool is switched off and when it is running idle in addition to the trigger time).

**⚠ WARNING:** Grinding thin sheets of metal or other easily vibrating structures with a large surface can result in a total noise emission much higher (up to 15 dB) than the declared noise emission values.

Set heavy flexible damping mats or such to those workpieces to prevent them from emitting sound.

Take the increased noise emission into consideration for both the risk assessment of noise exposure and selecting adequate hearing protection.

## Vibration

The vibration total value (tri-axial vector sum) determined according to EN62841-2-3:

Work mode: surface grinding with normal side grip

Model	Vibration emission ( $a_{h, AG}$ ) : ( $m/s^2$ )	Uncertainty (K) : ( $m/s^2$ )
GA7080	5.6	1.5
GA7081	6.8	1.5
GA7082	6.8	1.5
GA9080	5.2	1.5
GA9081	6.3	1.5
GA9082	6.3	1.5



## Work mode: surface grinding with anti vibration side grip

Model	Vibration emission ( $a_{h, AG}$ ) : (m/s <sup>2</sup> )	Uncertainty (K) : (m/s <sup>2</sup> )
GA7080	5.9	1.5
GA7081	7.3	1.5
GA7082	7.3	1.5
GA9080	5.3	1.5
GA9081	5.4	1.5
GA9082	5.4	1.5

## Work mode: disc sanding with normal side grip

Model	Vibration emission ( $a_{h, DS}$ ) : (m/s <sup>2</sup> )	Uncertainty (K) : (m/s <sup>2</sup> )
GA7080	3.6	1.5
GA7081	3.2	1.5
GA7082	3.2	1.5
GA9080	2.5 m/s <sup>2</sup> or less	1.5
GA9081	2.7	1.5
GA9082	2.7	1.5

## Work mode: disc sanding with anti vibration side grip

Model	Vibration emission ( $a_{h, DS}$ ) : (m/s <sup>2</sup> )	Uncertainty (K) : (m/s <sup>2</sup> )
GA7080	3.9	1.5
GA7081	3.1	1.5
GA7082	3.1	1.5
GA9080	2.5 m/s <sup>2</sup> or less	1.5
GA9081	3.1	1.5
GA9082	3.1	1.5

**NOTE:** The declared vibration total value(s) has been measured in accordance with a standard test method and may be used for comparing one tool with another.

**NOTE:** The declared vibration total value(s) may also be used in a preliminary assessment of exposure.

**⚠WARNING:** The vibration emission during actual use of the power tool can differ from the declared value(s) depending on the ways in which the tool is used especially what kind of workpiece is processed.

**⚠WARNING:** Be sure to identify safety measures to protect the operator that are based on an estimation of exposure in the actual conditions of use (taking account of all parts of the operating cycle such as the times when the tool is switched off and when it is running idle in addition to the trigger time).

**⚠WARNING:** The declared vibration emission value is used for main applications of the power tool. However if the power tool is used for other applications, the vibration emission value may be different.

## Declarations of Conformity

### For European countries only

The Declarations of conformity are included in Annex A to this instruction manual.

## SAFETY WARNINGS

### General power tool safety warnings

**⚠WARNING** Read all safety warnings, instructions, illustrations and specifications provided with this power tool. Failure to follow all instructions listed below may result in electric shock, fire and/or serious injury.

## Save all warnings and instructions for future reference.

The term "power tool" in the warnings refers to your mains-operated (corded) power tool or battery-operated (cordless) power tool.

### Grinder safety warnings

Safety warnings common for grinding, sanding, wire brushing, or cutting-off operations:

1. This power tool is intended to function as a grinder, sander, wire brush, hole cutter or cut-off tool. Read all safety warnings, instructions, illustrations and specifications provided with this power tool. Failure to follow all instructions listed below may result in electric shock, fire and/or serious injury.

2. **Operations such as polishing are not to be performed with this power tool.** Operations for which the power tool was not designed may create a hazard and cause personal injury.
  3. **Do not convert this power tool to operate in a way which is not specifically designed and specified by the tool manufacturer.** Such a conversion may result in a loss of control and cause serious personal injury.
  4. **Do not use accessories which are not specifically designed and specified by the tool manufacturer.** Just because the accessory can be attached to your power tool, it does not assure safe operation.
  5. **The rated speed of the accessory must be at least equal to the maximum speed marked on the power tool.** Accessories running faster than their rated speed can break and fly apart.
  6. **The outside diameter and the thickness of your accessory must be within the capacity rating of your power tool.** Incorrectly sized accessories cannot be adequately guarded or controlled.
  7. **The dimensions of the accessory mounting must fit the dimensions of the mounting hardware of the power tool.** Accessories that do not match the mounting hardware of the power tool will run out of balance, vibrate excessively and may cause loss of control.
  8. **Do not use a damaged accessory. Before each use inspect the accessory such as abrasive wheels for chips and cracks, backing pad for cracks, tear or excess wear, wire brush for loose or cracked wires. If power tool or accessory is dropped, inspect for damage or install an undamaged accessory. After inspecting and installing an accessory, position yourself and bystanders away from the plane of the rotating accessory and run the power tool at maximum no-load speed for one minute.** Damaged accessories will normally break apart during this test time.
  9. **Wear personal protective equipment. Depending on application, use face shield, safety goggles or safety glasses. As appropriate, wear dust mask, hearing protectors, gloves and workshop apron capable of stopping small abrasive or workpiece fragments.** The eye protection must be capable of stopping flying debris generated by various applications. The dust mask or respirator must be capable of filtering particles generated by the particular application. Prolonged exposure to high intensity noise may cause hearing loss.
  10. **Keep bystanders a safe distance away from work area. Anyone entering the work area must wear personal protective equipment.** Fragments of workpiece or of a broken accessory may fly away and cause injury beyond immediate area of operation.
  11. **Hold the power tool by insulated gripping surfaces only, when performing an operation where the cutting accessory may contact hidden wiring or its own cord.** Cutting accessory contacting a "live" wire may make exposed metal parts of the power tool "live" and could give the operator an electric shock.
  12. **Position the cord clear of the spinning accessory.** If you lose control, the cord may be cut or snagged and your hand or arm may be pulled into the spinning accessory.
  13. **Never lay the power tool down until the accessory has come to a complete stop.** The spinning accessory may grab the surface and pull the power tool out of your control.
  14. **Do not run the power tool while carrying it at your side.** Accidental contact with the spinning accessory could snag your clothing, pulling the accessory into your body.
  15. **Regularly clean the power tool's air vents.** The motor's fan will draw the dust inside the housing and excessive accumulation of powdered metal may cause electrical hazards.
  16. **Do not operate the power tool near flammable materials.** Sparks could ignite these materials.
  17. **Do not use accessories that require liquid coolants.** Using water or other liquid coolants may result in electrocution or shock.
- Kickback and related warnings:**
- Kickback is a sudden reaction to a pinched or snagged rotating wheel, backing pad, brush or any other accessory. Pinching or snagging causes rapid stalling of the rotating accessory which in turn causes the uncontrolled power tool to be forced in the direction opposite of the accessory's rotation at the point of the binding. For example, if an abrasive wheel is snagged or pinched by the workpiece, the edge of the wheel that is entering into the pinch point can dig into the surface of the material causing the wheel to climb out or kick out. The wheel may either jump toward or away from the operator, depending on direction of the wheel's movement at the point of pinching. Abrasive wheels may also break under these conditions.
- Kickback is the result of power tool misuse and/or incorrect operating procedures or conditions and can be avoided by taking proper precautions as given below.
1. **Maintain a firm grip with both hands on the power tool and position your body and arms to allow you to resist kickback forces. Always use auxiliary handle, if provided, for maximum control over kickback or torque reaction during start-up.** The operator can control torque reactions or kickback forces, if proper precautions are taken.
  2. **Never place your hand near the rotating accessory.** Accessory may kickback over your hand.
  3. **Do not position your body in the area where power tool will move if kickback occurs.** Kickback will propel the tool in direction opposite to the wheel's movement at the point of snagging.
  4. **Use special care when working corners, sharp edges, etc. Avoid bouncing and snagging the accessory.** Corners, sharp edges or bouncing have a tendency to snag the rotating accessory and cause loss of control or kickback.
  5. **Do not attach a saw chain woodcarving blade, segmented diamond wheel with a peripheral gap greater than 10 mm or toothed saw blade.** Such blades create frequent kickback and loss of control.

### Safety warnings specific for grinding and cutting-off operations:

1. **Use only wheel types that are specified for your power tool and the specific guard designed for the selected wheel.** Wheels for which the power tool was not designed cannot be adequately guarded and are unsafe.
2. **The grinding surface of centre depressed wheels must be mounted below the plane of the guard lip.** An improperly mounted wheel that projects through the plane of the guard lip cannot be adequately protected.
3. **The guard must be securely attached to the power tool and positioned for maximum safety, so the least amount of wheel is exposed towards the operator.** The guard helps to protect the operator from broken wheel fragments, accidental contact with wheel and sparks that could ignite clothing.
4. **Wheels must be used only for specified applications. For example: do not grind with the side of cut-off wheel.** Abrasive cut-off wheels are intended for peripheral grinding, side forces applied to these wheels may cause them to shatter.
5. **Always use undamaged wheel flanges that are of correct size and shape for your selected wheel.** Proper wheel flanges support the wheel thus reducing the possibility of wheel breakage. Flanges for cut-off wheels may be different from grinding wheel flanges.
6. **Do not use worn down wheels from larger power tools.** A wheel intended for larger power tool is not suitable for the higher speed of a smaller tool and may burst.
7. **When using dual purpose wheels always use the correct guard for the application being performed.** Failure to use the correct guard may not provide the desired level of guarding, which could lead to serious injury.

### Additional safety warnings specific for cutting-off operations:

1. **Do not "jam" the cut-off wheel or apply excessive pressure. Do not attempt to make an excessive depth of cut.** Overstressing the wheel increases the loading and susceptibility to twisting or binding of the wheel in the cut and the possibility of kickback or wheel breakage.
2. **Do not position your body in line with and behind the rotating wheel.** When the wheel, at the point of operation, is moving away from your body, the possible kickback may propel the spinning wheel and the power tool directly at you.
3. **When the wheel is binding or when interrupting a cut for any reason, switch off the power tool and hold it motionless until the wheel comes to a complete stop. Never attempt to remove the cut-off wheel from the cut while the wheel is in motion otherwise kickback may occur.** Investigate and take corrective action to eliminate the cause of wheel binding.
4. **Do not restart the cutting operation in the workpiece. Let the wheel reach full speed and carefully re-enter the cut.** The wheel may bind, walk up or kickback if the power tool is restarted in the workpiece.

5. **Support panels or any oversized workpiece to minimize the risk of wheel pinching and kickback.** Large workpieces tend to sag under their own weight. Supports must be placed under the workpiece near the line of cut and near the edge of the workpiece on both sides of the wheel.
6. **Use extra caution when making a "pocket cut" into existing walls or other blind areas.** The protruding wheel may cut gas or water pipes, electrical wiring or objects that can cause kickback.
7. **Do not attempt to do curved cutting.** Overstressing the wheel increases the loading and susceptibility to twisting or binding of the wheel in the cut and the possibility of kickback or wheel breakage, which can lead to serious injury.
8. **Before using a segmented diamond wheel, make sure that the diamond wheel has the peripheral gap between segments of 10 mm or less, only with a negative rake angle.**

### Safety warnings specific for sanding operations:

1. **Use proper sized sanding disc paper. Follow manufacturers recommendations, when selecting sanding paper.** Larger sanding paper extending too far beyond the sanding pad presents a laceration hazard and may cause snagging, tearing of the disc or kickback.

### Safety warnings specific for wire brushing operations:

1. **Be aware that wire bristles are thrown by the brush even during ordinary operation. Do not overstress the wires by applying excessive load to the brush.** The wire bristles can easily penetrate light clothing and/or skin.
2. **If the use of a guard is specified for wire brushing, do not allow any interference of the wire wheel or brush with the guard.** Wire wheel or brush may expand in diameter due to work load and centrifugal forces.

### Additional Safety Warnings:

1. **When using depressed centre grinding wheels, be sure to use only fiberglass-reinforced wheels.**
2. **NEVER USE Stone Cup type wheels with this grinder.** This grinder is not designed for these types of wheels and the use of such a product may result in serious personal injury.
3. **Be careful not to damage the spindle, the flange (especially the installing surface) or the lock nut. Damage to these parts could result in wheel breakage.**
4. **Make sure the wheel is not contacting the workpiece before the switch is turned on.**
5. **Before using the tool on an actual workpiece, let it run for a while. Watch for vibration or wobbling that could indicate poor installation or a poorly balanced wheel.**
6. **Use the specified surface of the wheel to perform the grinding.**
7. **Do not leave the tool running. Operate the tool only when hand-held.**
8. **Do not touch the workpiece immediately after operation; it may be extremely hot and could burn your skin.**

9. Do not touch accessories immediately after operation; it may be extremely hot and could burn your skin.
10. Observe the instructions of the manufacturer for correct mounting and use of wheels. Handle and store wheels with care.
11. Do not use separate reducing bushings or adaptors to adapt large hole abrasive wheels.
12. Use only flanges specified for this tool.
13. For tools intended to be fitted with threaded hole wheel, ensure that the thread in the wheel is long enough to accept the spindle length.
14. Check that the workpiece is properly supported.
15. Pay attention that the wheel continues to rotate after the tool is switched off.
16. If working place is extremely hot and humid, or badly polluted by conductive dust, use a short-circuit breaker (30 mA) to assure operator safety.
17. Do not use the tool on any materials containing asbestos.
18. When use cut-off wheel, always work with the dust collecting wheel guard if required by domestic regulation.
19. Cutting discs must not be subjected to any lateral pressure.
20. Do not use cloth work gloves during operation. Fibers from cloth gloves may enter the tool, which causes tool breakage.
21. Before operation, make sure that there is no buried object such as electric pipe, water pipe or gas pipe in the workpiece. Otherwise, it may cause an electric shock, electrical leakage or gas leak.
22. If a blotter is attached to the wheel, do not remove it. The diameter of the blotter must be larger than the lock nut, outer flange, and inner flange.
23. Before installing a grinding wheel, always check that the blotter part does not have any abnormalities such as chips or cracks.
24. Tighten the lock nut properly. Overtightening the wheel can cause breakage and insufficient tightening can cause fluttering.

## SAVE THESE INSTRUCTIONS.

**⚠ CAUTION:** DO NOT let comfort or familiarity with product (gained from repeated use) replace strict adherence to safety rules for the subject product. MISUSE or failure to follow the safety rules stated in this instruction manual may cause serious personal injury.

## FUNCTIONAL DESCRIPTION

**⚠ CAUTION:** Always be sure that the tool is switched off and unplugged before adjusting or checking function on the tool.

### Indication lamp

Only for model GA7080 / GA7081 / GA9080 / GA9081  
 ► Fig.1: 1. Indication lamp

The indication lamp lights up green when the tool is plugged.  
 If the indication lamp does not light up, the mains cord or the controller may be defective.  
 The indication lamp is lit but the tool does not start even if the tool is switched on, the carbon brushes may be worn out, or the controller, the motor or the ON/OFF switch may be defective.

### Shaft lock

**⚠ WARNING:** Never actuate the shaft lock when the spindle is moving. It may cause serious injury or the tool damage.

Press the shaft lock to prevent spindle rotation when installing or removing accessories.  
 ► Fig.2: 1. Shaft lock

### Switch handle mounting positions

Only for model GA7080 / GA9080

**⚠ CAUTION:** Always make sure that the switch handle is locked in the desired position before operation.

The switch handle can be rotated to either 90° left or right to fit your work needs. First, unplug the tool. Press the lock button and rotate the switch handle to left or right fully. The switch handle will be locked in that position.  
 ► Fig.3: 1. Motor housing 2. Lock button 3. Handle

### Switch action

**⚠ CAUTION:** Before plugging in the tool, always check to see that the switch trigger actuates properly and returns to the "OFF" position when released.

**⚠ CAUTION:** Make sure to switch off the tool in case of a blackout or accidental shut down such as unplugging of the power cord. Otherwise the tool will start unexpectedly when the power supply is recovered and cause an accident or personal injury.

There are three patterns of the switch action depending on country.

► Fig.4: 1. Switch trigger 2. Lock lever

## For tool with the lock-on switch

### Country specific

**CAUTION:** Switch can be locked in "ON" position for ease of operator comfort during extended use. Apply caution when locking tool in "ON" position and maintain firm grasp on tool.

To start the tool, simply pull the switch trigger (in the B direction). Release the switch trigger to stop.

For continuous operation, pull the switch trigger (in the B direction) and then push in the lock lever (in the A direction).

To stop the tool from the locked position, pull the switch trigger fully (in the B direction), then release it.

## For tool with the lock-off switch

### Country specific (including Australia and New Zealand)

To prevent the switch trigger from accidentally pulled, a lock lever is provided.

To start the tool, push in the lock lever (in the A direction) and then pull the switch trigger (in the B direction). Release the switch trigger to stop.

**NOTICE:** Do not pull the switch trigger hard without pressing in the lock lever. This can cause switch breakage.

## For tool with the lock-on and lock-off switch

### Country specific

**CAUTION:** Switch can be locked in "ON" position for ease of operator comfort during extended use. Apply caution when locking tool in "ON" position and maintain firm grasp on tool.

To prevent the switch trigger from accidentally pulled, a lock lever is provided.

To start the tool, push in the lock lever (in the A direction) and then pull the switch trigger (in the B direction). Release the switch trigger to stop.

For continuous operation, push in the lock lever (in the A direction), pull the switch trigger (in the B direction) and then pull the lock lever (in the C direction).

To stop the tool from the locked position, pull the switch trigger fully (in the B direction), then release it.

**NOTICE:** Do not pull the switch trigger hard without pressing in the lock lever. This can cause switch breakage.

## Accidental re-start preventive function

### Only for model GA7080 / GA7081 / GA9080 / GA9081

When plugging in the tool while the switch is ON, the tool does not start.

At this time, the indication lamp blinks in red and shows that the accidental re-start preventive function works.

To start the tool, turn off the switch, and turn it on again.

## Soft start feature

### Only for model GA7080 / GA7081 / GA9080 / GA9081

Soft start feature reduces starting reaction.

## ASSEMBLY

**CAUTION:** Always be sure that the tool is switched off and unplugged before carrying out any work on the tool.

## Installing side grip (handle)

**CAUTION:** Always be sure that the side grip is installed securely before operation.

**CAUTION:** You can install the side grip on the 3 holes. Install the side grip on one of the holes according to the operation.

Screw the side grip securely on the position of the tool as shown in the figure.

► Fig.5

## Installing or removing loop handle

### Optional accessory

**CAUTION:** Always be sure the bolts on the loop handle is securely tightened before use.

**CAUTION:** Hold the gripping area of the loop handle specified in the figure. Also, keep the hand away from the metal part of the grinder during operation. Touching the metal part may result in electric shock, if the cutting attachment cuts live wire unexpectedly.

The loop handle can be more comfortable than the original side grip for some applications. To install the loop handle, mount it onto the tool as illustrated and tighten two bolts to fix it.

To remove the loop handle, follow the installation procedure in reverse.

► Fig.6: 1. Loop handle 2. Bolt 3. Gripping area

## Installing or removing wheel guard (For depressed center wheel, flap disc, flex wheel, wire wheel brush / abrasive cut-off wheel, diamond wheel)

**WARNING:** When using a depressed center wheel, flap disc, flex wheel or wire wheel brush, the wheel guard must be fitted on the tool so that the closed side of the guard always points toward the operator.

**WARNING:** When using an abrasive cut-off / diamond wheel, be sure to use only the special wheel guard designed for use with cut-off wheels.

## For tool with locking screw type wheel guard

Mount the wheel guard with the protrusions on the wheel guard band aligned with the notches on the bearing box. Then rotate the wheel guard to such an angle that it can protect the operator according to work. Be sure to tighten the screw securely.

To remove wheel guard, follow the installation procedure in reverse.

► **Fig.7:** 1. Wheel guard 2. Bearing box 3. Screw

## For tool with clamp lever type wheel guard

Loosen the nut, and then pull the lever in the direction of the arrow.

► **Fig.8:** 1. Nut 2. Lever

Mount the wheel guard with the protrusions on the wheel guard band aligned with the notches on the bearing box. Then rotate the wheel guard to such an angle that it can protect the operator according to work.

► **Fig.9:** 1. Wheel guard 2. Bearing box

► **Fig.10:** 1. Wheel guard

Securely tighten the nut using a spanner, and then close the lever in direction of the arrow to fasten the wheel guard. If the lever is too tight or too loose to fasten the wheel guard, open the lever and then loosen or tighten the nut using the spanner to adjust the tightening of the wheel guard band.

► **Fig.11:** 1. Nut 2. Lever

To remove wheel guard, follow the installation procedure in reverse.

## Installing or removing depressed center wheel or flap disc

### Optional accessory

**⚠WARNING:** When using a depressed center wheel or flap disc, the wheel guard must be fitted on the tool so that the closed side of the guard always points toward the operator.

**⚠WARNING:** Make sure that the mounting part of the inner flange fits into the inner diameter of the depressed center wheel / flap disc perfectly. Mounting the inner flange on the wrong side may result in the dangerous vibration.

Mount the inner flange onto the spindle.

Make sure to fit the dented part of the inner flange onto the straight part at the bottom of the spindle.

Fit the wheel/disc on the inner flange and screw the lock nut with its protrusion facing downward (facing towards the wheel).

► **Fig.12:** 1. Lock nut 2. Depressed center wheel 3. Inner flange 4. Mounting part

To tighten the lock nut, press the shaft lock firmly so that the spindle cannot revolve, then use the lock nut wrench and securely tighten clockwise.

► **Fig.13:** 1. Lock nut wrench 2. Shaft lock

To remove the wheel, follow the installation procedure in reverse.

## Installing or removing flex wheel

### Optional accessory

**⚠WARNING:** Always use supplied guard when flex wheel is on the tool. Wheel can shatter during use and guard helps to reduce chances of personal injury.

► **Fig.14:** 1. Lock nut 2. Flex wheel 3. Back up pad 4. Inner flange

Follow instructions for depressed center wheel but also use back up pad over wheel.

## Installing or removing abrasive disc

### Optional accessory

► **Fig.15:** 1. Sanding lock nut 2. Abrasive disc 3. Rubber pad

1. Mount the rubber pad onto the spindle.
2. Fit the disc on the rubber pad and screw the sanding lock nut onto the spindle.
3. Hold the spindle with the shaft lock, and securely tighten the sanding lock nut clockwise with the lock nut wrench.

To remove the disc, follow the installation procedure in reverse.

**NOTE:** Use sander accessories specified in this manual. These must be purchased separately.

## Super Flange

### Optional accessory

Super Flange is a special accessory for model which is NOT equipped with a brake function.

Models with the letter F are standard-equipped with Super Flange. Only 1/3 of efforts needed to undo lock nut, compared with conventional type.

## Installing or removing Ezynut

### Optional accessory

Only for tools with M14 spindle thread.

**⚠CAUTION:** Do not use Ezynut with Super Flange. Those flanges are so thick that the entire thread cannot be retained by the spindle.

Mount inner flange, abrasive wheel and Ezynut onto the spindle so that Makita Logo on Ezynut faces outside.

► **Fig.16:** 1. Ezynut 2. Abrasive wheel 3. Inner flange 4. Spindle

Press shaft lock firmly and tighten Ezynut by turning the abrasive wheel clockwise as far as it turns.

► **Fig.17:** 1. Shaft lock

To loosen the Ezynut, turn the outside ring of Ezynut counterclockwise.

**NOTE:** Ezynut can be loosened by hand as long as the arrow points the notch. Otherwise a lock nut wrench is required to loosen it. Insert one pin of the wrench into a hole and turn Ezynut counterclockwise.

► **Fig.18:** 1. Arrow 2. Notch

► **Fig.19**

## Installing abrasive cut-off / diamond wheel

### Optional accessory

**⚠WARNING:** When using an abrasive cut-off / diamond wheel, be sure to use only the special wheel guard designed for use with cut-off wheels.

**⚠WARNING:** NEVER use cut-off wheel for side grinding.

Mount the inner flange onto the spindle.

Fit the wheel / disc on the inner flange and screw the lock nut onto the spindle.

► **Fig.20:** 1. Lock nut 2. Abrasive cut-off wheel / diamond wheel 3. Inner flange 4. Wheel guard for abrasive cut-off wheel / diamond wheel

### For Australia and New Zealand

► **Fig.21:** 1. Lock nut 2. Outer flange 78 3. Abrasive cut-off wheel / diamond wheel 4. Inner flange 78 5. Wheel guard for abrasive cut-off wheel / diamond wheel

## Installing wire cup brush

### Optional accessory

**⚠CAUTION:** Do not use brush that is damaged, or which is out of balance. Use of damaged brush could increase potential for injury from contact with broken brush wires.

Place the tool upside down to allow easy access to the spindle. Remove any accessories on spindle. Thread wire cup brush onto spindle and tighten with supplied wrench.

► **Fig.22:** 1. Wire cup brush

## Installing wire wheel brush

### Optional accessory

**⚠CAUTION:** Do not use wire wheel brush that is damaged, or which is out of balance. Use of damaged wire wheel brush could increase potential for injury from contact with broken wires.

**⚠CAUTION:** ALWAYS use guard with wire wheel brushes, assuring diameter of wheel fits inside guard. Wheel can shatter during use and guard helps to reduce chances of personal injury.

Place the tool upside down to allow easy access to the spindle.

Remove any accessories on spindle. Thread wire wheel brush onto spindle and tighten with the wrenches.

► **Fig.23:** 1. Wire wheel brush

## Installing hole cutter

### Optional accessory

Place the tool upside down to allow easy access to the spindle.

Remove any accessories on the spindle. Thread the hole cutter onto the spindle, and tighten it with the supplied wrench.

► **Fig.24:** 1. Hole cutter

## Installing dust collecting wheel guard for grinding

Only for model GA7080 / GA7081 / GA9080 / GA9081

### Optional accessory

With optional accessories, you can use this tool for planing concrete surface.

**⚠CAUTION:** Dust collecting wheel guard for grinding is only for use in planing concrete surface with a cup-type diamond wheel. Do not use this guard with any other cutting accessory or for any other purpose.

**⚠CAUTION:** Before operation, make sure that a vacuum cleaner is connected to the tool and turned on.

Place the tool upside down and install the dust collecting wheel guard.

Mount the inner flange onto the spindle.

Fit the cup-type diamond wheel on the inner flange and tighten the lock nut onto the spindle.

► **Fig.25:** 1. Lock nut 2. Cup-type diamond wheel 3. Hubbed cup-type diamond wheel 4. Inner flange 5. Dust collecting wheel guard 6. Bearing box

**NOTE:** For information how to install the dust collecting wheel guard, refer to the manual of the dust collecting wheel guard.

## Installing dust collecting wheel guard for cutting-off

### Optional accessory

With optional accessories, you can use this tool for cutting stone materials.

► **Fig.26**

**NOTE:** For information how to install the dust collecting wheel guard, refer to the manual of the dust collecting wheel guard.

## Connecting a vacuum cleaner

### Optional accessory

**⚠WARNING:** Never vacuum metal particles created by grinding/cutting/sanding operation. Metal particles created by such operation are so hot that they ignite dust and the filter inside the vacuum cleaner.

To avoid dusty environment caused by masonry cutting, use a dust collecting wheel guard and a vacuum cleaner.

Refer to the instruction manual attached to the dust collecting wheel guard for assembling and using it.

► **Fig.27:** 1. Dust collecting wheel guard 2. Hose of the vacuum cleaner

## Installing or removing dust cover attachment

### Optional accessory

**CAUTION:** Always be sure that the tool is switched off and unplugged before installing or removing the dust cover attachment. Failure to do so causes damage to the tool or a personal injury.

Install the dust cover attachment to each specified position.

For details, refer to the instruction manual of the dust cover attachment.

**NOTICE:** Clean out the dust cover attachment when it is clogged with dust or foreign matters. Continuing operation with a clogged dust cover attachment will damage the tool.

## OPERATION

**WARNING:** It should never be necessary to force the tool. The weight of the tool applies adequate pressure. Forcing and excessive pressure could cause dangerous wheel breakage.

**WARNING:** ALWAYS replace wheel if tool is dropped while grinding.

**WARNING:** NEVER hit the workpiece with the wheel.

**WARNING:** Avoid bouncing and snagging the wheel, especially when working corners, sharp edges etc. This can cause loss of control and kickback.

**WARNING:** NEVER use tool with wood cutting blades and other saw blades. Such blades when used on a grinder frequently kick and cause loss of control leading to personal injury.

**CAUTION:** Never switch on the tool when it is in contact with the workpiece, it may cause an injury to operator.

**CAUTION:** Always wear safety goggles or a face shield during operation.

**CAUTION:** After operation, always switch off the tool and wait until the wheel has come to a complete stop before putting the tool down.

**CAUTION:** ALWAYS hold the tool firmly with one hand on housing and the other on the side grip (handle).

**NOTE:** A dual purpose wheel can be used for both grinding and cutting-off operations.

Refer to the "Grinding and sanding operation" for grinding operation, and refer to the "Operation with abrasive cut-off / diamond wheel" for cutting-off operation.

## Grinding and sanding operation

### ► Fig.28

Turn the tool on and then apply the wheel or disc to the workpiece. In general, keep the edge of the wheel or disc at an angle of about 15° to the workpiece surface.

During the break-in period with a new wheel, do not work the grinder in forward direction or it may cut into the workpiece. Once the edge of the wheel has been rounded off by use, the wheel may be worked in both forward and backward direction.

**Usage example: operation with cup-type diamond wheel**

### ► Fig.29

Keep the tool horizontally and apply the entire cup-type diamond wheel to the workpiece surface.

## Operation with abrasive cut-off / diamond wheel

### Optional accessory

**WARNING:** Do not "jam" the wheel or apply excessive pressure. Do not attempt to make an excessive depth of cut. Overstressing the wheel increases the loading and susceptibility to twisting or binding of the wheel in the cut and the possibility of kickback, wheel breakage and overheating of the motor may occur.

**WARNING:** Do not start the cutting operation in the workpiece. Let the wheel reach full speed and carefully enter into the cut moving the tool forward over the workpiece surface. The wheel may bind, walk up or kickback if the power tool is started in the workpiece.

**WARNING:** During cutting operations, never change the angle of the wheel. Placing side pressure on the cut-off wheel (as in grinding) will cause the wheel to crack and break, causing serious personal injury.

**WARNING:** A diamond wheel shall be operated perpendicular to the material being cut.

For model GA7080 / GA9080, you can rotate the switch handle.

### ► Fig.30

### ► Fig.31

## Operation with wire cup brush

### Optional accessory

**CAUTION:** Check operation of brush by running tool with no load, insuring that no one is in front of or in line with brush.

**NOTICE:** Avoid applying too much pressure which causes over bending of wires when using the wire cup brush. It may lead to premature breakage.

**Usage example: operation with wire cup brush**

### ► Fig.32



## Operation with wire wheel brush

### Optional accessory

**CAUTION:** Check operation of wire wheel brush by running tool with no load, insuring that no one is in front of or in line with the wire wheel brush.

**NOTICE:** Avoid applying too much pressure which causes over bending of wires when using wire wheel brush. It may lead to premature breakage.

Usage example: operation with wire wheel brush  
► Fig.33

## Operation with hole cutter

### Optional accessory

**CAUTION:** Check operation of the hole cutter by running the tool with no load, insuring that no one is in front of the hole cutter.

**NOTICE:** Do not tilt the tool during operation. It may lead to premature breakage.

Usage example: operation with hole cutter  
► Fig.34

## MAINTENANCE

**CAUTION:** Always be sure that the tool is switched off and unplugged before attempting to perform inspection or maintenance.

**NOTICE:** Never use gasoline, benzine, thinner, alcohol or the like. Discoloration, deformation or cracks may result.

To maintain product SAFETY and RELIABILITY, repairs, carbon brush inspection and replacement, any other maintenance or adjustment should be performed by Makita Authorized or Factory Service Centers, always using Makita replacement parts.

## Air vent cleaning

The tool and its air vents have to be kept clean. Regularly clean the tool's air vents or whenever the vents start to become obstructed.

► Fig.35: 1. Exhaust vent 2. Inhalation vent

**NOTE:** Do not loosen the screw on the cover. Otherwise the cover may be opened accidentally.

► Fig.36: 1. Screw

# COMBINATION OF APPLICATIONS AND ACCESSORIES

## Optional accessory

**⚠CAUTION:** Using the tool with incorrect guards can cause risks as follows.

- When using a cut-off wheel guard for facial grinding, the wheel guard may interfere with the workpiece causing poor control.
- When using a grinding wheel guard for cutting-off operations with bonded abrasive wheels and diamond wheels, there is an increased risk of exposure to rotating wheels, emitted sparks and particles, as well as exposure to wheel fragments in the event of wheel burst.
- When using a cut-off wheel guard or grinding wheel guard for facial operations with cup-type diamond wheels, the wheel guard may interfere with the workpiece causing poor control.
- When using a cut-off wheel guard or grinding wheel guard with a wheel-type wire brush with a thickness greater than the maximum thickness as specified in "SPECIFICATIONS", the wires may catch on the guard leading to breaking of wires.
- Use of dust collecting wheel guards for cutting-off and facial operations in concrete or masonry reduces a risk of exposure to dust.
- When using dual purpose (combined grinding and cutting-off abrasive) flange mounted wheels, only use a cut-off wheel guard.

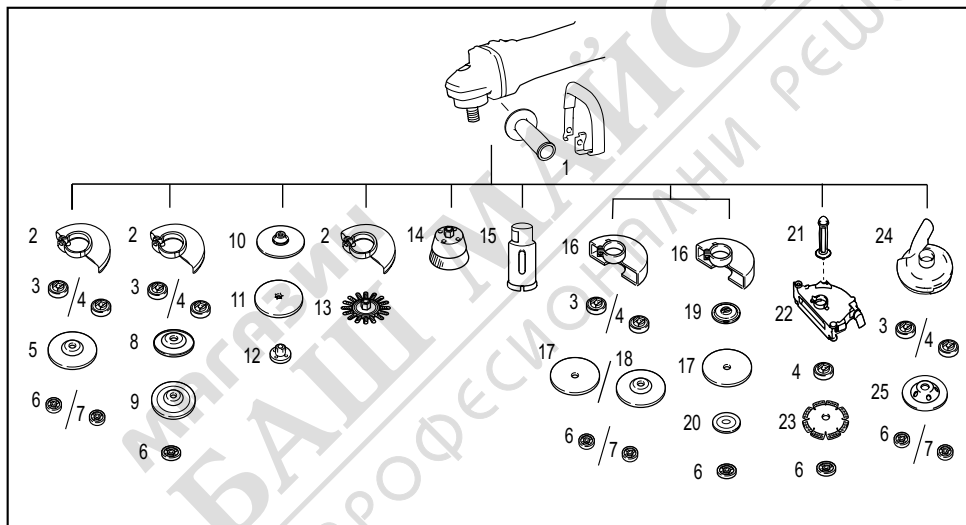

-	Application	180 mm model	230 mm model
1	-	Side grip / Loop handle	
2	-	Wheel guard (for grinding wheel)	
3	-	Inner flange	
4	-	Super Flange *1	
5	Grinding / Sanding	Depressed center wheel / Flap disc	
6	-	Lock nut	
7	-	Eznut *1*2	
8	-	Back up pad	
9	Grinding	Flex wheel	
10	-	Rubber pad	
11	Sanding	Abrasive disc	
12	-	Sanding lock nut	
13	Wire brushing	Wire wheel brush	

	Application	180 mm model	230 mm model
14	Wire brushing	Wire cup brush	
15	Hole cutting	Hole cutter	
16	-	Wheel guard (for cut-off wheel)	
17	Cutting-off	Abrasives cut-off wheel / Diamond wheel	
18	Grinding / Cutting-off	Dual purpose wheel	-
19	-	Inner flange 78 (Australia and New Zealand only) *3	
20	-	Outer flange 78 (Australia and New Zealand only) *3	
21	-	Side grip for dust collecting wheel guard *4	
22	-	Dust collecting wheel guard for cutting-off *4*5	
23	Cutting-off	Diamond wheel	
24	-	Dust collecting wheel guard for grinding *6	
25	Grinding	Cup-type diamond wheel *6	
-	-	Lock nut wrench	
-	-	Dust cover attachment	

**NOTE:** \*1 Do not use Super Flange and Ezy Nut together.

**NOTE:** \*2 Only for tools with M14 spindle thread.

**NOTE:** \*3 Use Inner flange 78 and Outer flange 78 together. (Australia and New Zealand only)

**NOTE:** \*4 Use the Side grip for dust collecting wheel guard and the Dust collecting wheel guard for cutting-off together.

**NOTE:** \*5 For more details, refer to each instruction manual of the guard.

**NOTE:** \*6 Only for model GA7080 / GA7081 / GA9080 / GA9081

For more details, refer to each instruction manual of the guard.

## OPTIONAL ACCESSORIES

**CAUTION:** These accessories or attachments are recommended for use with your Makita tool specified in this manual. The use of any other accessories or attachments might present a risk of injury to persons. Only use accessory or attachment for its stated purpose.

If you need any assistance for more details regarding these accessories, ask your local Makita Service Center.

- Accessories listed in "COMBINATION OF APPLICATIONS AND ACCESSORIES"

**NOTE:** Some items in the list may be included in the tool package as standard accessories. They may differ from country to country.