



Nothing but **HEAVY DUTY**.<sup>®</sup>



## AS 300 ELCP



Original instructions

Originalbetriebsanleitung

Notice originale

Istruzioni originali

Manual original

Oorspronkelijke gebruiksaanwijzing

Original brugsanvisning

Original bruksanvisning

Bruksanvisning i original

Alkuperäiset ohjeet

Πρωτότυπο οδηγιών χρήσης

Orijinal işletme talimatı

Původním návodem k používání

Pôvodný návod na použitie

Instrukcją oryginalną

Eredeti használati utasítás

Izvirna navodila

Originalne pogonske upute

Instrukcijām oriģinālvalodā

Originali instrukcija

Algupärane kasutusjuhend

Оригинальное руководство по эксплуатации

Оригинално ръководство за експлоатация

Instrucțiuni de folosire originale

Оригинален прирачник за работа

التعليمات الأصلية

Technical Data, Safety Instructions, Specified Conditions of Use, EC-Declaration of Conformity, Mains connection, Maintenance, Symbols	Please read and save these instructions!	<b>ENGLISH</b>	<b>20</b>
Technische Daten, Sicherheitshinweise, Bestimmungsgemäße Verwendung, CE-Konformitätserklärung, Netzanschluss, Wartung, Symbole	Bitte lesen und aufbewahren!	<b>DEUTSCH</b>	<b>22</b>
Caractéristiques techniques, Instructions de sécurité, Utilisation conforme aux prescriptions, Déclaration CE de Conformité, Branchement secteur, Entretien, Symboles	Prière de lire et de conserver!	<b>FRANÇAIS</b>	<b>24</b>
Dati tecnici, Norme di sicurezza, Utilizzo conforme, Dichiarazione di Conformità CE, Collegamento alla rete, Manutenzione, Simboli	Si prega di leggere le istruzioni e di conservarle!	<b>ITALIANO</b>	<b>26</b>
Datos técnicos, Instrucciones de seguridad, Aplicación de acuerdo a la finalidad, Declaración de Conformidad CE, Conexión eléctrica, Mantenimiento, Símbolos	Lea y conserve estas instrucciones por favor!	<b>ESPAÑOL</b>	<b>28</b>
Características técnicas, Instruções de segurança, Utilização autorizada, Declaração de Conformidade CE, Ligações à rede, Manutenção, Símbolo	Por favor leia e conserve em seu poder!	<b>PORTUGUES</b>	<b>30</b>
Technische gegevens, Veiligheidsadviezen, Voorgeschreven gebruik van het systeem, EC-Konformiteitsverklaring, Netaansluiting, Onderhoud, Symbolen	Lees en let goed op deze adviezen!	<b>NEDERLANDS</b>	<b>32</b>
Tekniske data, Sikkerhedshenvisninger, Tiltænkt formål, CE-Konformitetserklæring, Netttilslutning, Vedligeholdelse, Symboler	Vær venlig at læse og opbevare!	<b>DANSK</b>	<b>34</b>
Tekniske data, Spesielle sikkerhetshenvisninger, Formålmessig bruk, CE-Samsvarserklæring, Netttilkopling, Vedlikehold, Symboler	Vennligst les og oppbevar!	<b>NORSK</b>	<b>36</b>
Tekniska data, Säkerhetsutrustning, Använd maskinen Enligt anvisningarna, CE-Försäkran, Nätanslutning, Skötsel, Symboler	Var god läs och tag tillvara dessa instruktioner!	<b>SVENSKA</b>	<b>38</b>
Tekniset arvot, Turvallisuusohjeet, Tarkoituksenmukainen käyttö, Todistus CE-standardin mukaisuudesta, Verkkoliitäntä, Huolto, Symbolit	Lue ja säilytö!	<b>SUOMI</b>	<b>40</b>
Τεχνικά στοιχεία, Ειδικά υποδείξεις ασφαλείας, Χρήση σύμφωνα με το σκοπό προορισμού, Δήλωση πιστότητας εκ, Σύνδεση στο ηλεκτρικό δίκτυο, Συντήρηση, Σύμβολα	Παρακαλώ διαβάστε τις και φυλάξτε τις!	<b>ΕΛΛΗΝΙΚΑ</b>	<b>42</b>
Teknik veriler, Güvenliğiniz için talimatlar, Kullanım, CE uygunluk beyanince, Şebeke bağlantısı, Bakım, Semboller	Lütfen okuyun ve saklayın	<b>TÜRKÇE</b>	<b>44</b>
Technická data, Speciální bezpečnostní upozornění, Oblast využití, Ce-prohlášení o shodě, Připojení na síť, Udržba, Symboly	Po přečtení uschovejte	<b>ČESKY</b>	<b>46</b>
Technické údaje, Speciálne bezpečnostné pokyny, Použitie podľa predpisov, CE-Vyhlasenie konformity, Sieťové pripojka, Údržba, Symboly	Prosím prečítať a uschovať!	<b>SLOVENSKY</b>	<b>48</b>
Dane techniczne, Specjalne zalecenia dotyczace bezpieczerstwa, Uzytkowanie zgodne z przeznaczeniem, Swiadectwo zgodnosci ce, Podlaczenie do sieci, Gwarancja, Symbole	Prosimy o uwazne przeczytanie i przestrzeganie zalececi zamie szonych w tej	<b>POLSKI</b>	<b>50</b>
Műszaki adatok, Különleges biztonsági tudnivalók, Rendeltetésszerű használat, Ce-azonossági nyilatkozat, Hálózati csatlakoztatás, Karbantartás, Szimbólumok	Olvassa el és őrizze meg	<b>MAGYAR</b>	<b>52</b>
Tehnični podatki, Specialni varnostni napotki, Uporaba v skladu z namembnostjo, Ce-izjava o konformnosti, Omrežni priključek, Vzdrževanje, Simboli	Prosimo preberite in shranite!	<b>SLOVENSKO</b>	<b>54</b>
Tehnički podaci, Specijalne sigurnosne upute, Propisna upotreba, Ce-izjava konformnosti, Priključak na mrežu, Održavanje, Simboli	Molimo pročitati i sačuvati	<b>HRVATSKI</b>	<b>56</b>
Tehniskie dati, Speciālie drošības noteikumi, Noteikumiem atbilstošs izmantojums, Atbilstība CE normām, Tīkla pieslēgums, Apkope, Simboli	Pielikums lietošanas pamācībai	<b>LATVISKI</b>	<b>58</b>
Techniniai duomenys, Ypatingos saugumo nuorodos, Naudojimas pagal paskirtį, CE Atitikties pareiškinimas, Elektros tinklo jungtis, Techninis aptarnavimas, Simboliai	Prašome perskaityti ir neiškemti!	<b>LIETUVIŠKAI</b>	<b>60</b>
Tehnilised andmed, Spetsiaalsed turvajuhised, Kasutamise vastavalt otstarbele, EÜ Vastavusavaldus, Võrku ühendamine, Hooldus, Sümbolid	Palun lugege läbi ja hoidke alal!	<b>EESTI</b>	<b>62</b>
Технические данные, Рекомендации по технике безопасности, Использо- вание, Подключение к электросети, Обслуживание, Символы	Пожалуйста, прочтите и сохраните настоящую инструкцию	<b>РУССКИЙ</b>	<b>64</b>
Технически данни, Специални указания за безопасност, Използване по предназначение, CE-Декларация за съответствие, Съвързване към мрежата, Поддръжка, Символи	Моля прочетете и запазете!	<b>БЪЛГАРСКИ</b>	<b>66</b>
Date tehnice, Instrucțiuni de securitate, Condiții de utilizare specificate, Declarație de conformitate, Alimentare de la rețea, Intreținere, Simboluri	Va rugăm citiți și păstrați aceste instrucțiuni	<b>ROMÂNIA</b>	<b>68</b>
Технички Податоци, Упатство За Употреба, Специфицирани Услови На Употреба, Еу-декларација За Сообразност, Главни Врски, Одржување, Символи	Ве молиме прочитајте го и чувајте го ова упатство!	<b>МАКЕДОНСКИ</b>	<b>70</b>
العربية البيانات الفنية، تعليمات السلامة، شروط الاستخدام المحددة، إعلان التوافق من الاتحاد الأوروبي، التوصيل بمصدر التيار الكهربائي، الصيانة، الرموز	يرجى قراءة هذه التعليمات وحفظها في مكان آمن!	<b>عربي</b>	<b>73</b>

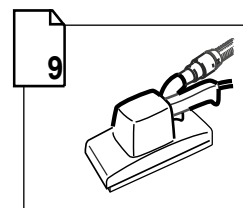
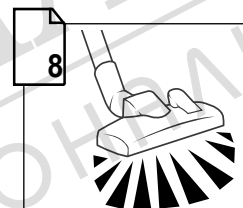
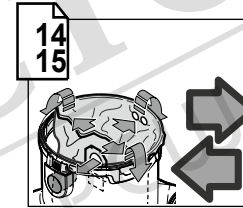
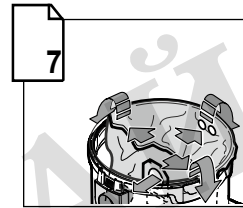
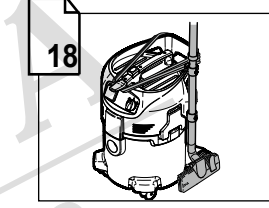
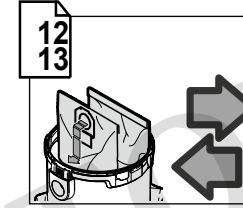
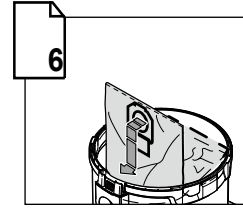
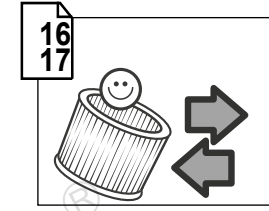
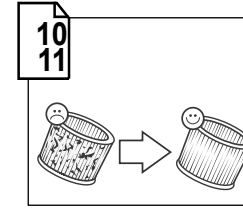
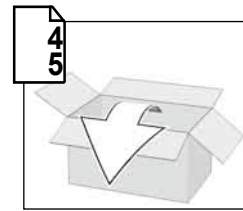

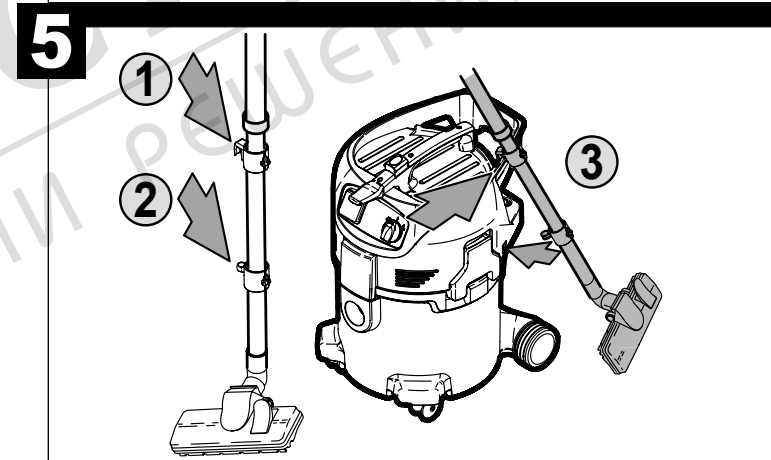
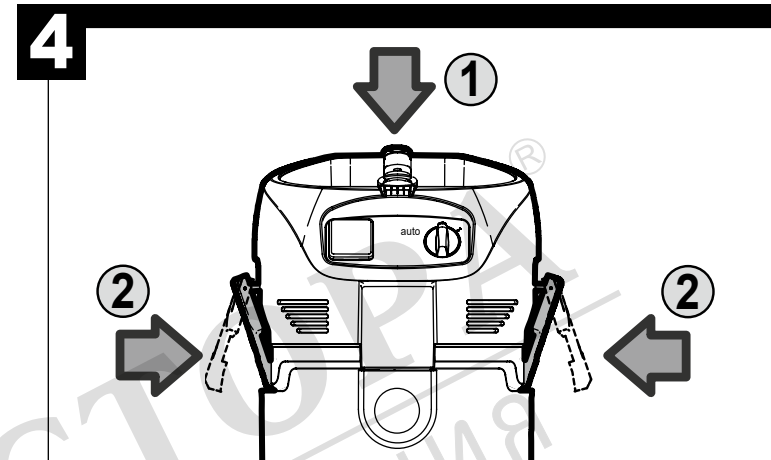
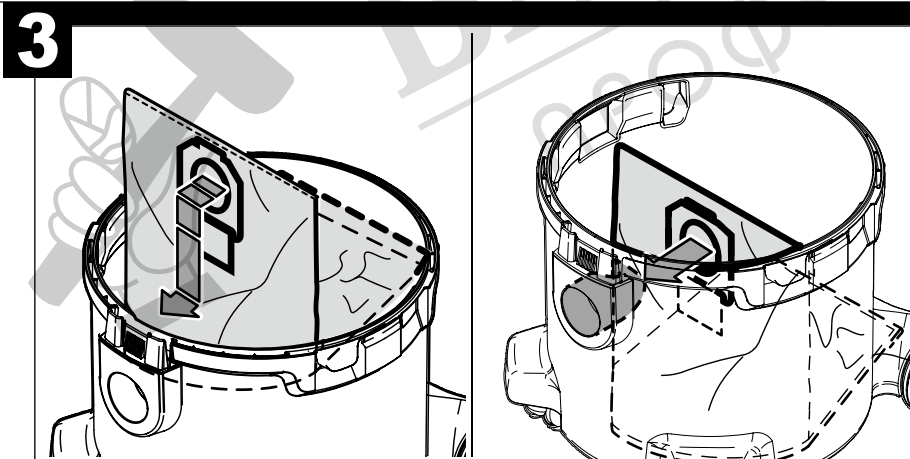
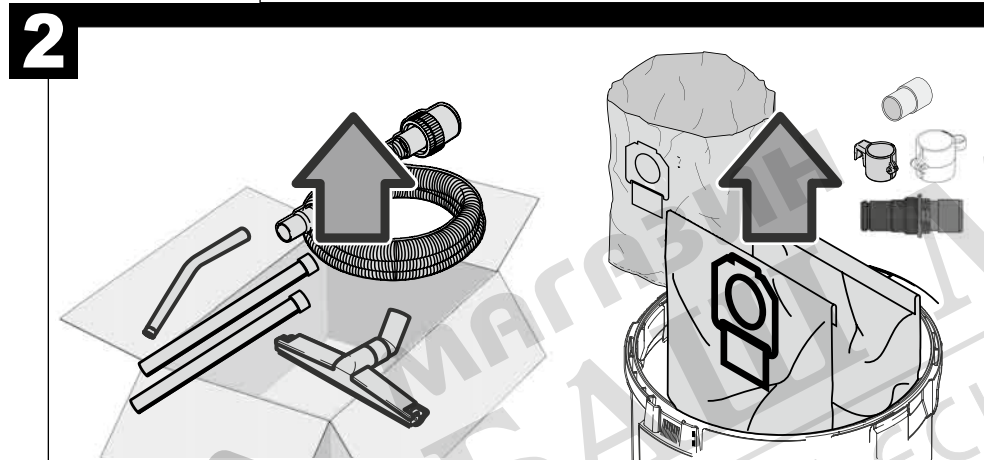
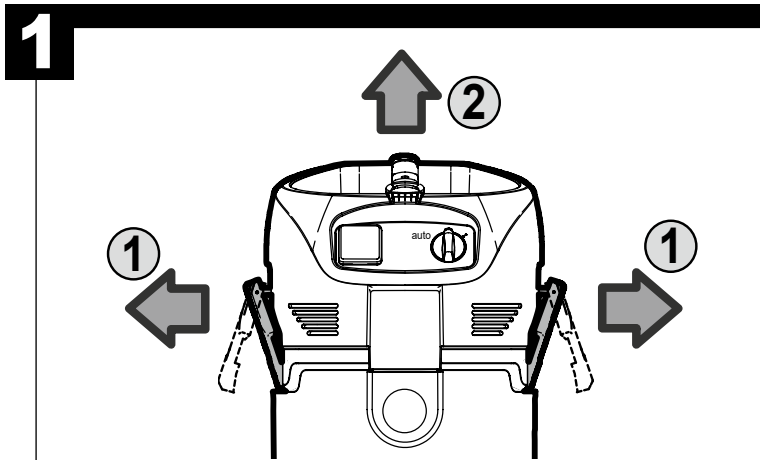
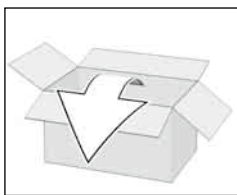

Zubehör - Im Lieferumfang nicht enthalten, empfohlene Ergänzung aus dem Zubehörprogramm.  
Accessory - Not included in standard equipment, available as an accessory.

Accessoires - Ces pièces ne font pas partie de la livraison. Il s'agit là de compléments recommandés pour votre machine et énumérés dans le catalogue des accessoires.

Accessorio - Non incluso nella dotazione standard, disponibile a parte come accessorio.

Accessorio - No incluido en el equipo estándar, disponible en la gama de accesorios.

Accessório - Não incluído no equipamento normal, disponível como acessório.

Toebehoren - Wordt niet meegeleverd. Is apart leverbaar. Zie hiervoor het toebehorenprogramma.

Tilbehør - Ikke inkluderet i leveringsomfanget, køb købes som tilbehør.

Tilbehør - inngår ikke i leveransen, anbefalt komplettering fra tilbehørsprogrammet.

Tilbehør - Ingår ej i leveransomfanget, erhålls som tilbehør.

Lisälate - Ei sisällyä vakiovarustukseen, saatavana lisätarvikkeena.

Εξαρτήματα - Δεν περιλαμβάνονται στα υλικά παράδοσης, συστατούμενη προσθήκη από το πρόγραμμα εξαρτημάτων.

Aksesuar - Teslimat kapsamında değildir, önerilen tamamlayıcı aksesuar programında.

Příslušenství není součástí dodávky, viz program příslušenství.

Priřluštenstvo - nie je súčasťou štandardnej výbavy, odporúčané doplnenie z programu prířluštenstva.

Wyposażenie dodatkowe dostępne osobno.

Azokat a tartozékokat, amelyek gyárilag nincsenek a készülékhez mellékelve, külön lehet megrendelni.

Oprema - ni vsebovana v obsegu dobave, priporočeno dopnililo iz programa opreme.

Oprema - u opsegu isporuke nije sadržana, preporučena dopuna iz programa opreme.

Piederumi - standartaprīkojumā neietvertās, bet ieteicamās papildus komplektācijas detaļās no piederumu programmas.

Priedas - neįeina į tiekimo komplektaciją, rekomenduojamas papildymas iš priedų asortimento.

Tarvikud - ei kuulu tarne komplekti, soovitatav

täiendus on saadaval tarvikute programmis.

Дополнитель - В стандартную комплектацию не входит, поставляется в качестве дополнительной принадлежности.

Аксесори - Не се съдържат в обема на доставката, препоръчано допълнение от програмата за аксесори.

Accessorii - Nu este inclus în echipamentul standard, disponibil ca accesorii.

Дополнителна опрема - Не е включена во стандартната, а доставана е како додаток.

ق ح ل ك ر ف و ت م ء ة ي س ا و ي ق د ح ل م ل

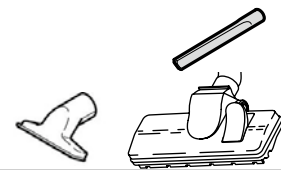

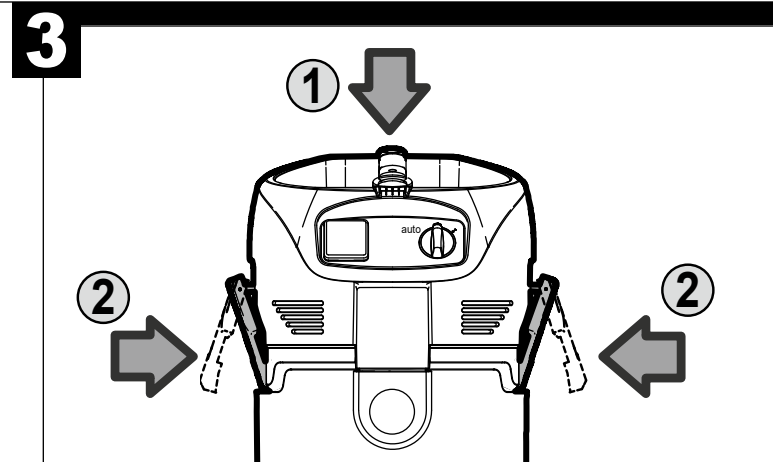
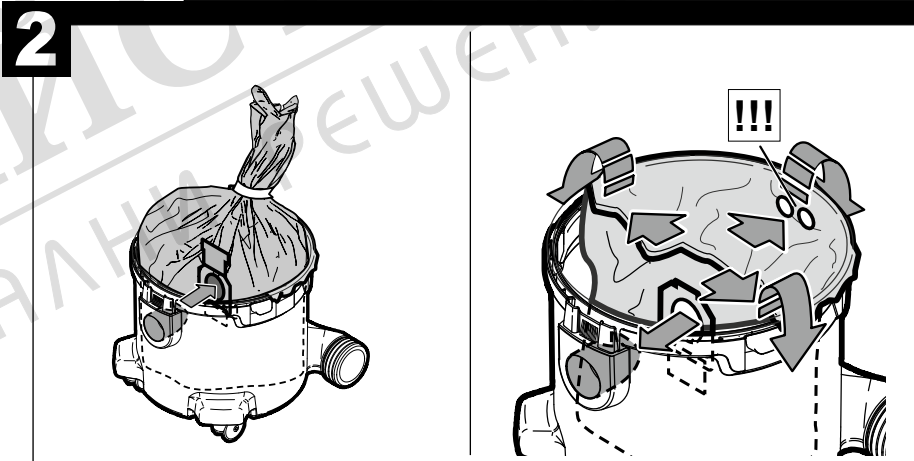
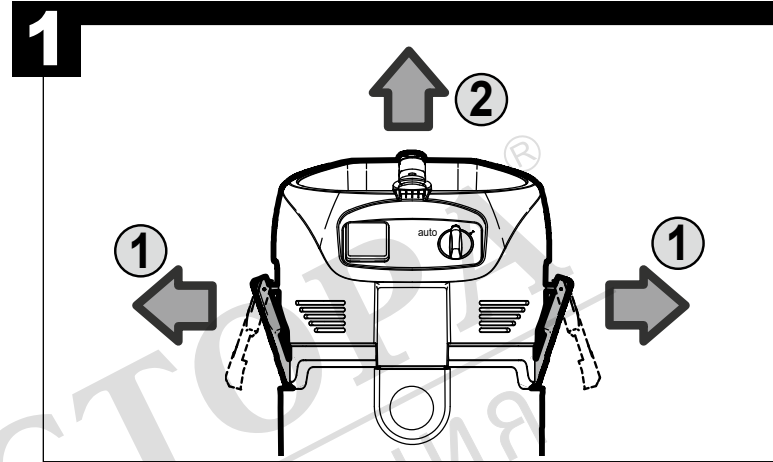
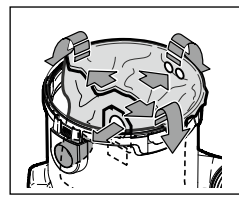
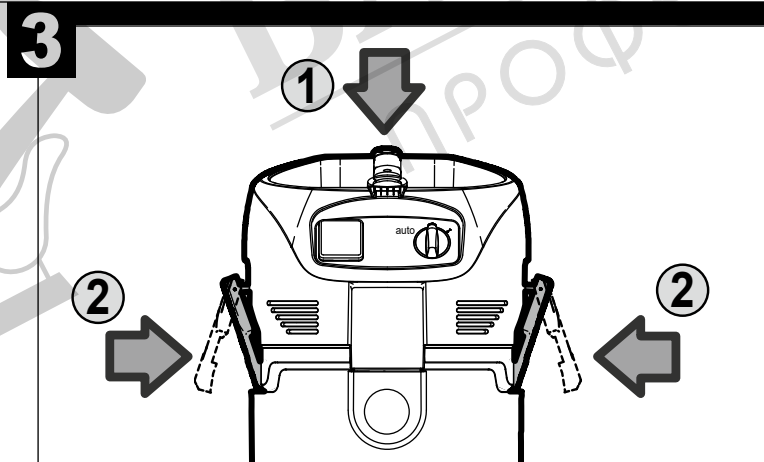
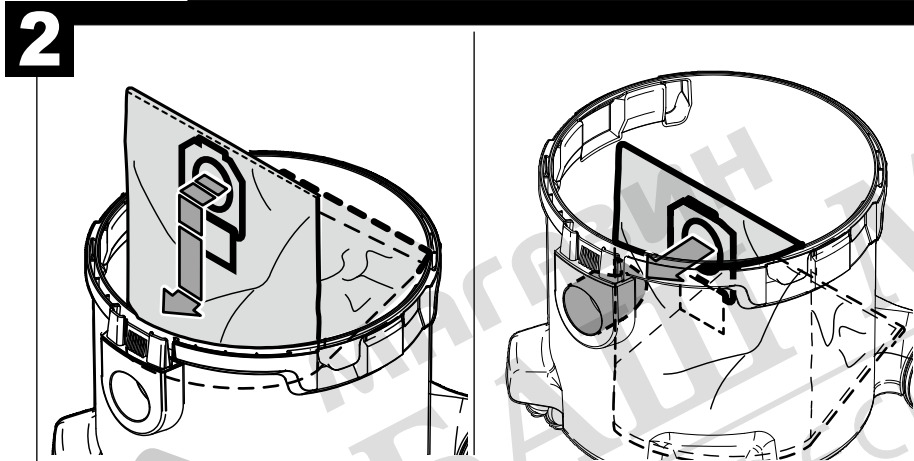
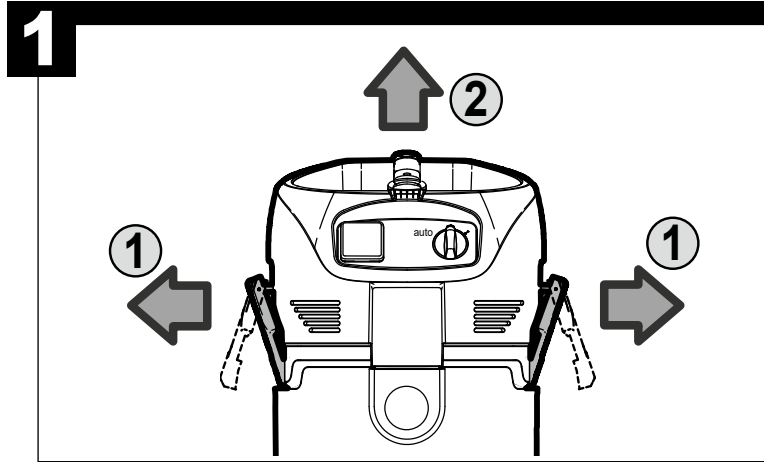
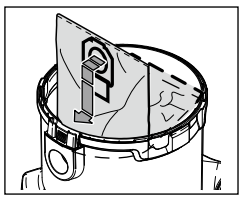

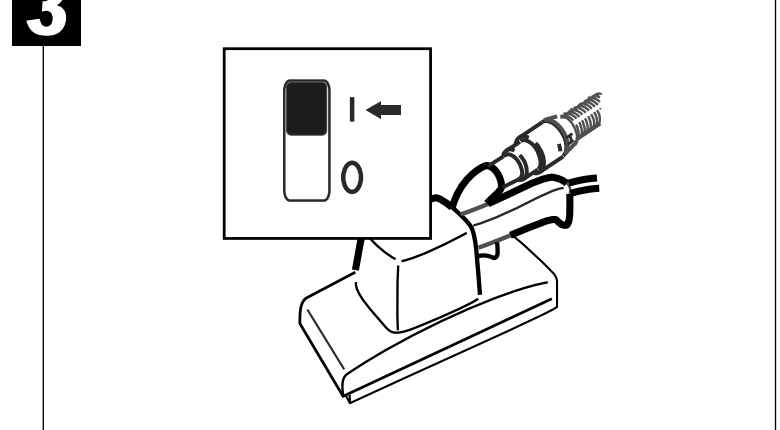
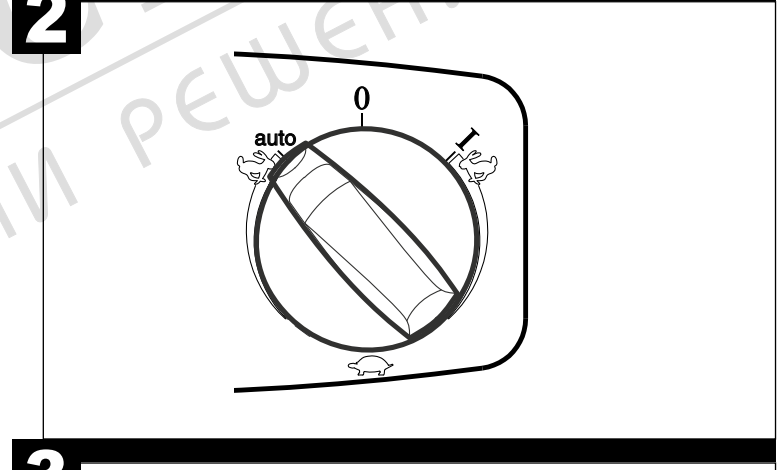
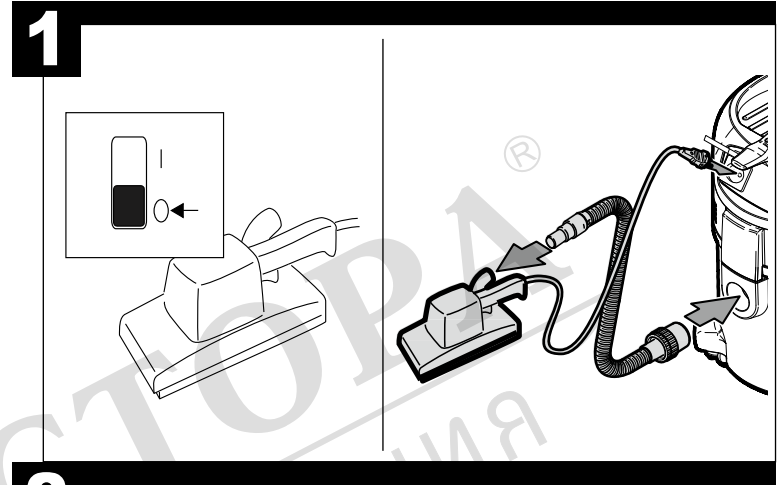
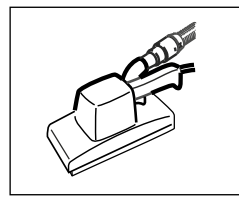
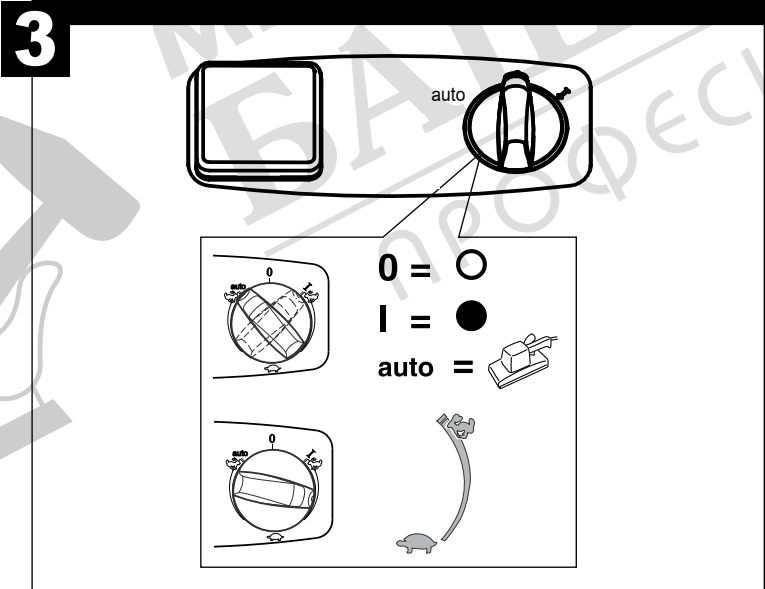
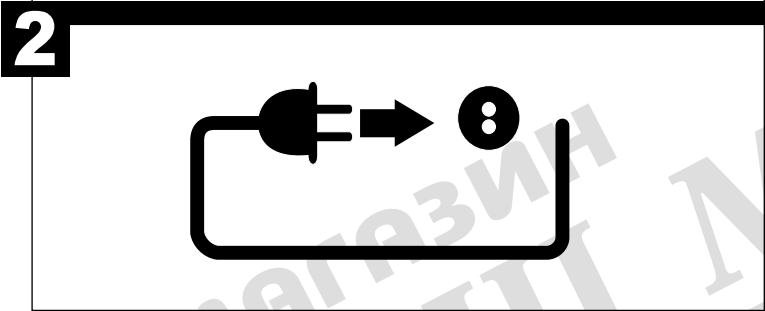
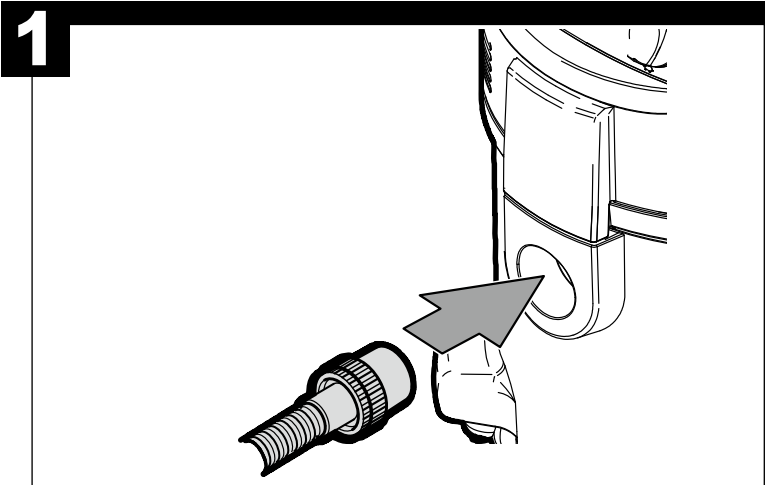

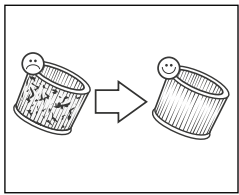

**Clear-Press**  
Filter Cleaning System

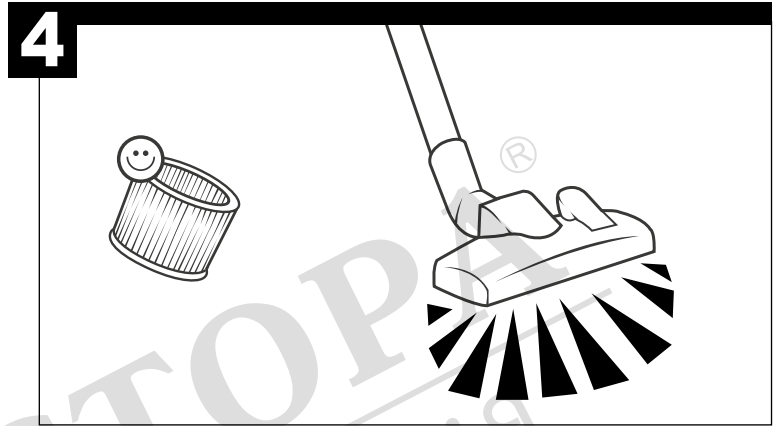
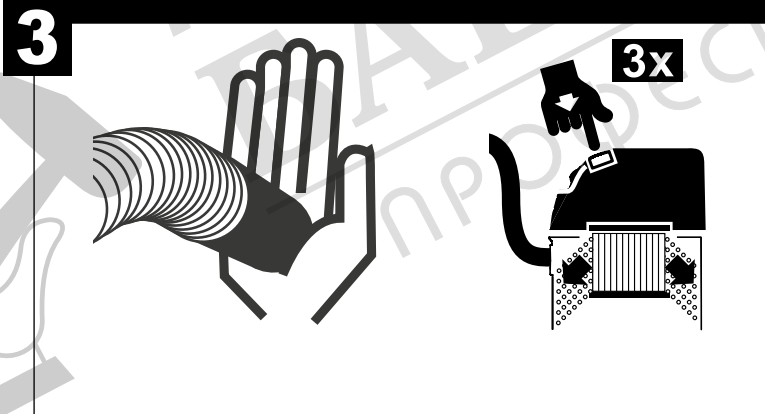
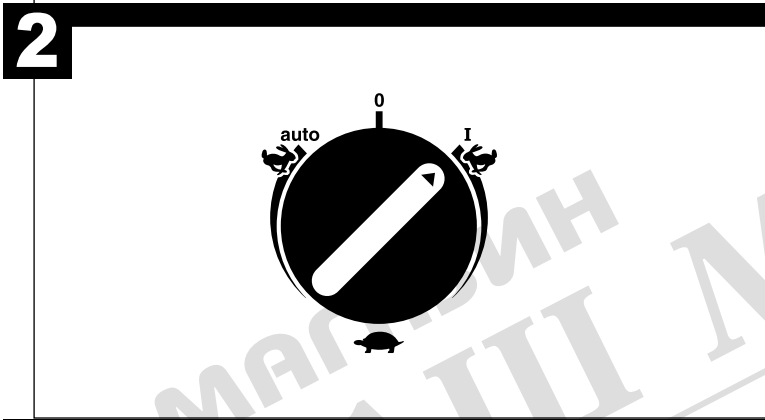
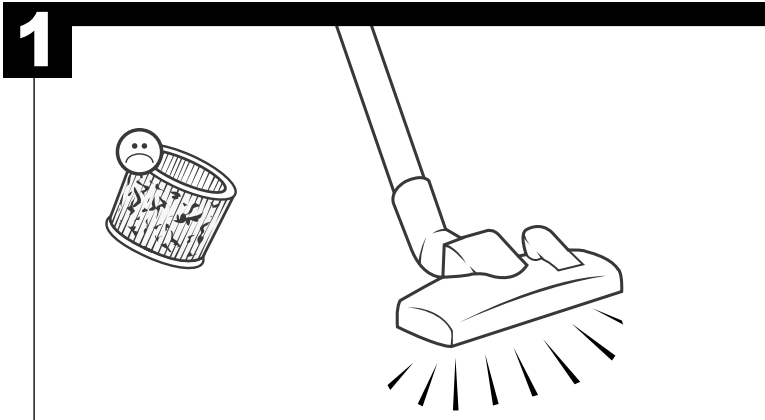

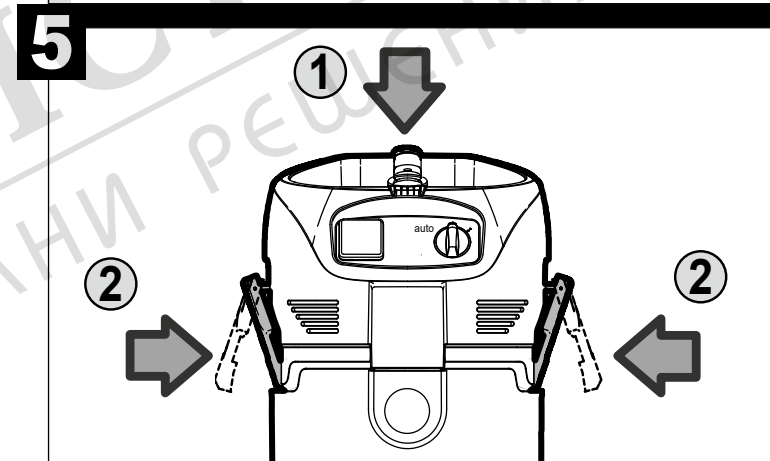
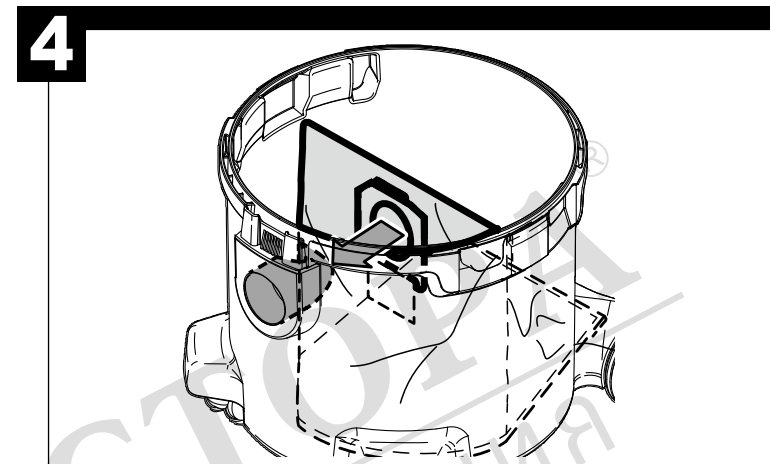
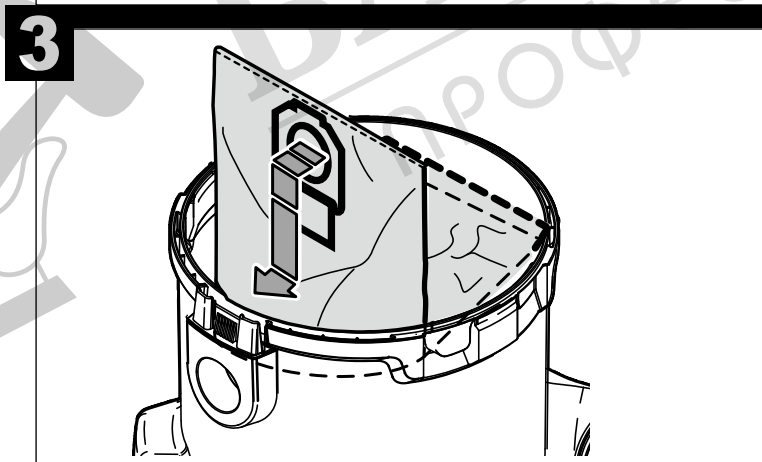
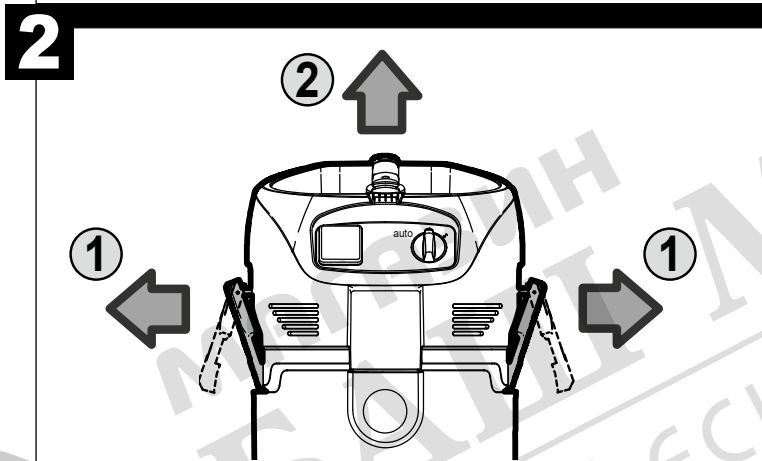
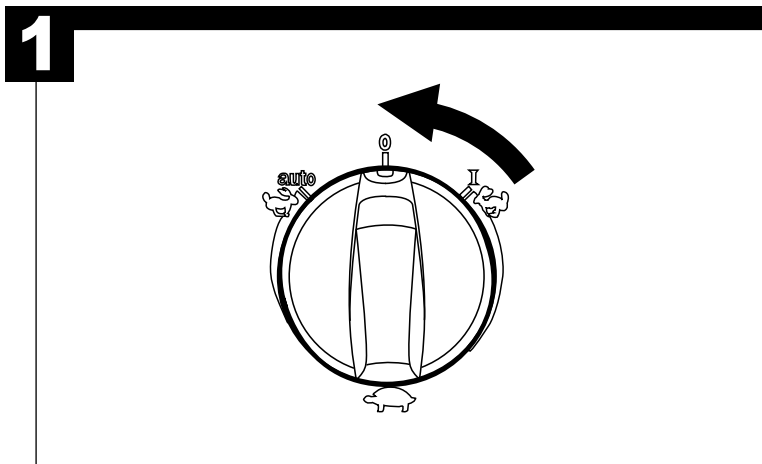
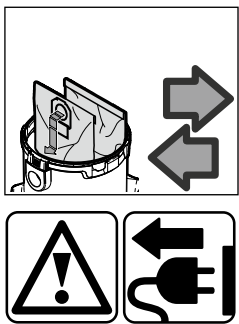

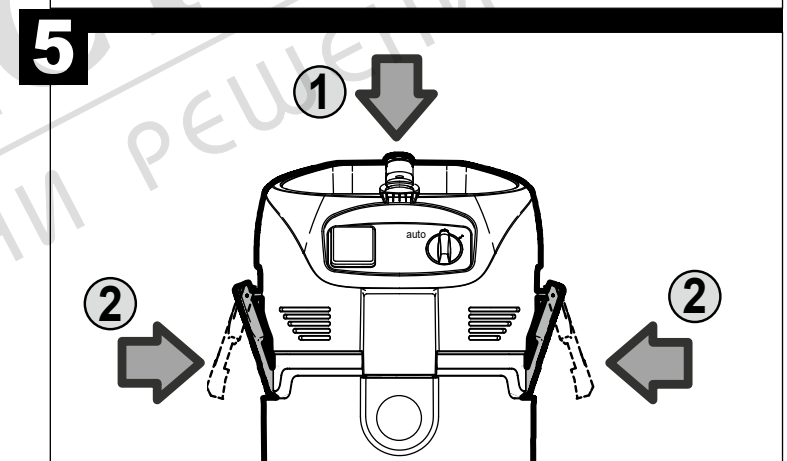
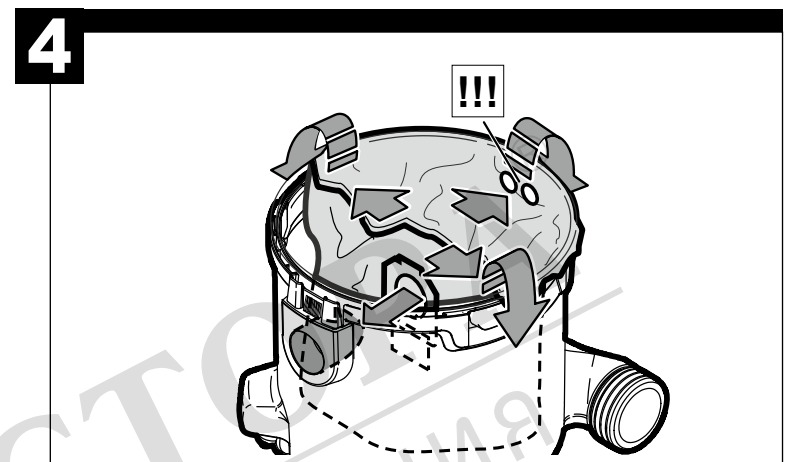
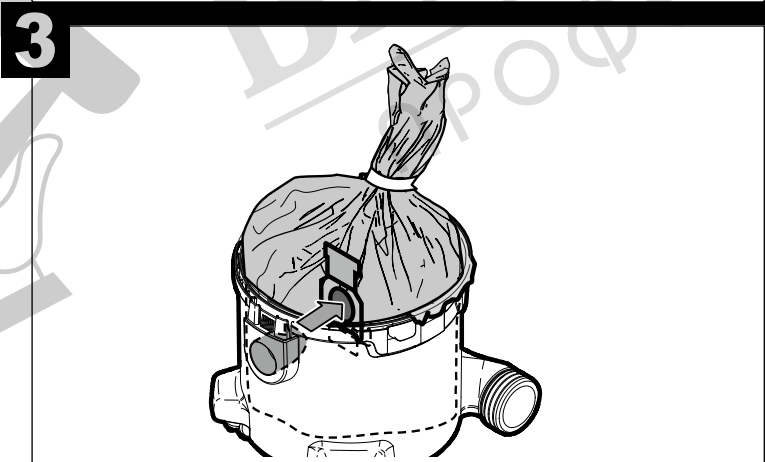
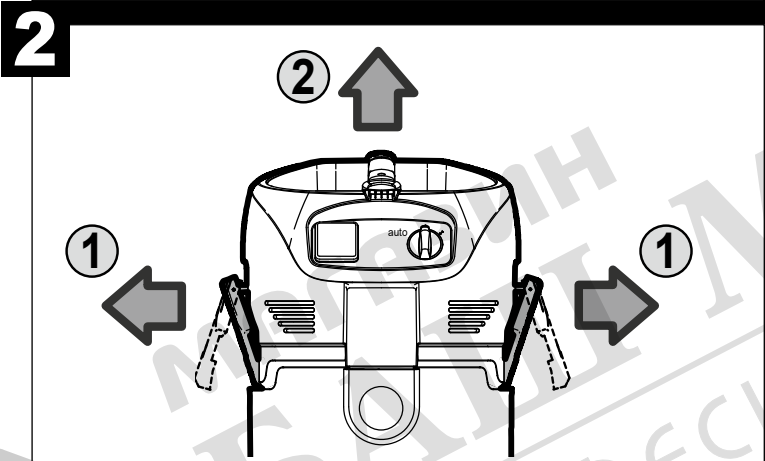
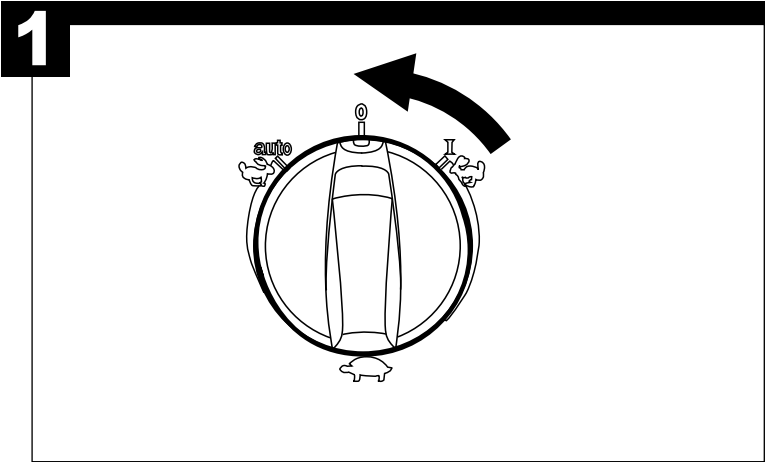
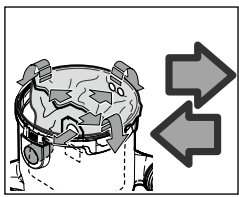



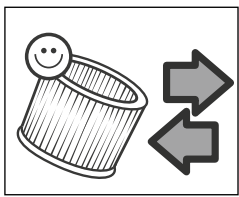

**1**

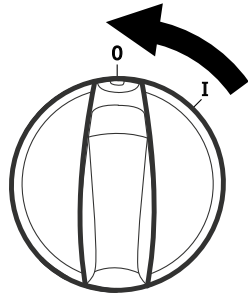

**2**

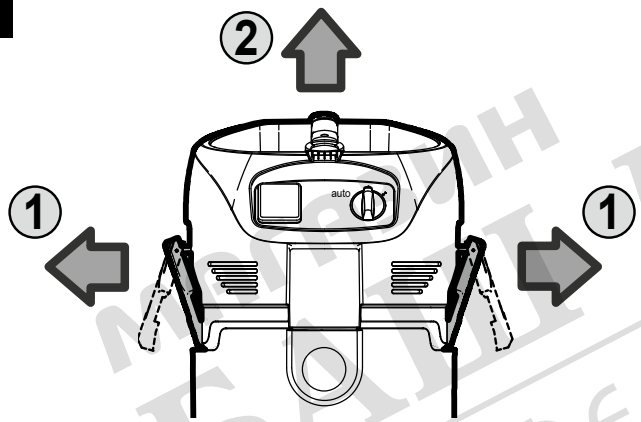

**3**

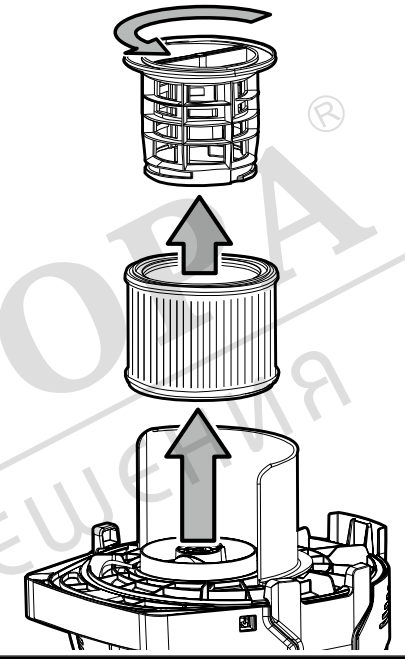

**4**

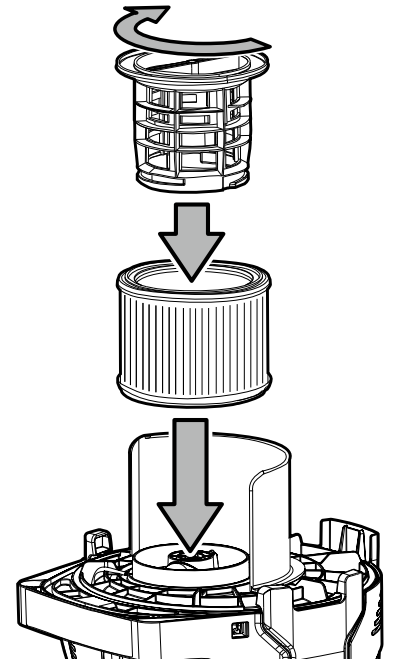

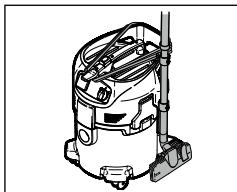

**1**

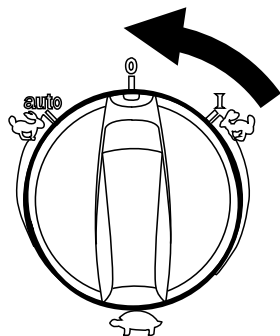

**2**

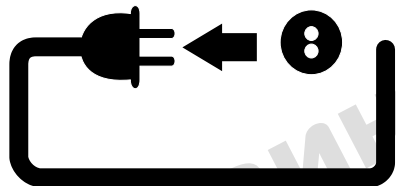

**3**

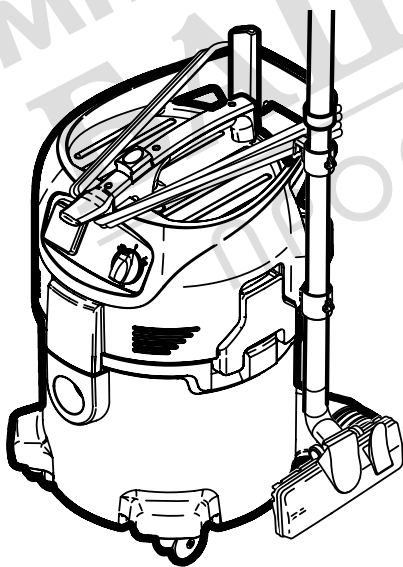

МАГАЗИН МАЙСТОРА®  
ПРОФЕСІОНАЛНИ РЕШЕННЯ

