

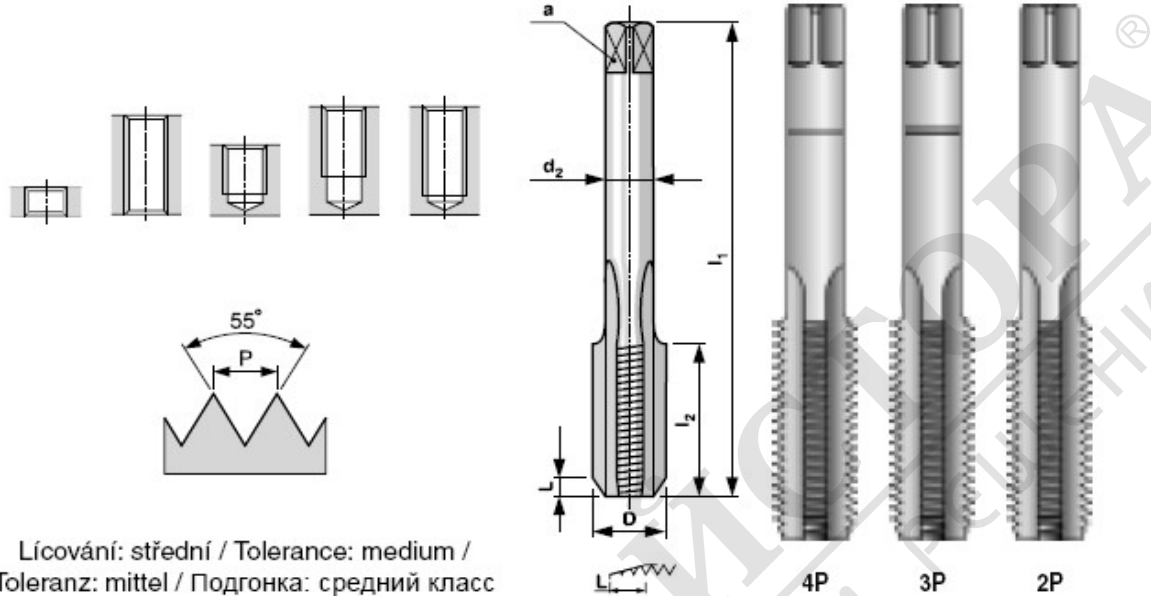

## ТЕХНИЧЕСКА ХАРАКТЕРИСТИКА



Lícování: střední / Tolerance: medium /  
Toleranz: mittel / Подгонка: средний класс

## МЕТЧИЦИ

Характеристики:

D	z/1"	P	l <sub>1</sub>	l <sub>2</sub>	d <sub>2</sub>	a		*	code NO/CS	code HSS
W 3/32"	48	0,529	34	10	3,15	2,5	1,75	3	111 332	141 332
W 1/8"	40	0,635	37	12	4	3,15	2,4	3	111 180	141 180
W 5/32"	32	0,794	41	14	5	4	3,0	3	111 532	141 532
W 3/16"	24	1,058	44	18	5	4	3,5	3	111 316	141 316
W 7/32"	24	1,058	44	18	5,6	4,5	4,3	3	111 732	141 732
W 1/4"	20	1,270	48	22	6,3	5	4,9	3	111 140	141 140
W 5/16"	18	1,411	51	26	5,6	4,5	6,4	3	111 516	141 516
W 3/8"	16	1,588	60	26	7,1	5,6	7,7	3	111 380	141 380
W 7/16"	14	1,814	60	28	8	6,3	9,1	3	111 716	141 716
W 1/2"	12	2,117	70	32	9	7,1	10,3	3	111 120	141 120
W 9/16"	12	2,117	70	32	9	7,1	11,8	3	111 916	141 916
W 5/8"	11	2,309	80	36	12,5	10	13,25	3	111 580	141 580
W 3/4"	10	2,540	90	40	14	11,2	16,25	3	111 340	141 340
W 7/8"	9	2,822	100	45	18	14	19	3	111 780	141 780
W 1"	8	3,175	110	45	20	16	21,75	3	111 100	141 100