

- D** Originalbetriebsanleitung
Zug-, Kapp- und Gehrungssäge
- GB** Original operating instructions
Drag, crosscut and miter saw
- F** Instructions d'origine
Scie à onglet radiale
- I** Istruzioni per l'uso originali
Sega a trazione per troncatore e tagli obliqui
- S** Original-bruksanvisning
Drag-, kap- och geringssåg
- CZ** Originální návod k obsluze
Kapovací a pokosová pila s pojezdem
- SK** Originálny návod na obsluhu
Tesárska, kapovacia a pokosová pila
- NL** Originele handleiding
Trek-, afkort- en verstekzaag
- E** Manual de instrucciones original
Sierra de tracción, oscilante y para cortar ingleses
- FIN** Alkuperäiskäyttöohje
Veto-, katkaisu- ja jiirisaha
- SLO** Originalna navodila za uporabo
Dvoročna žaga, čelična žaga in zajeralna žaga
- H** Eredeti használati utasítás
Vonó-, fejező- és sarkaló fűrész
- GR** Πρωτότυπες Οδηγίες χρήσης
Φαλτσοπρίονο και πριόνι κάθετης κοπής
- P** Manual de instruções original
Serra de tração, corte transversal e meia-esquadria
- TR** Orijinal Kullanma Talimatı
Gönye kesme

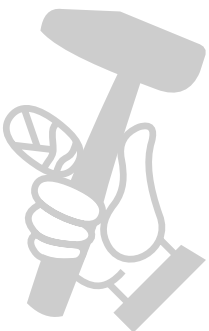

13   



Art.-Nr.: 43.003.95

I.-Nr.: 21022

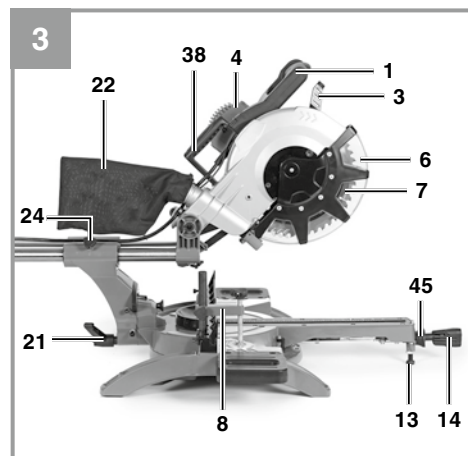
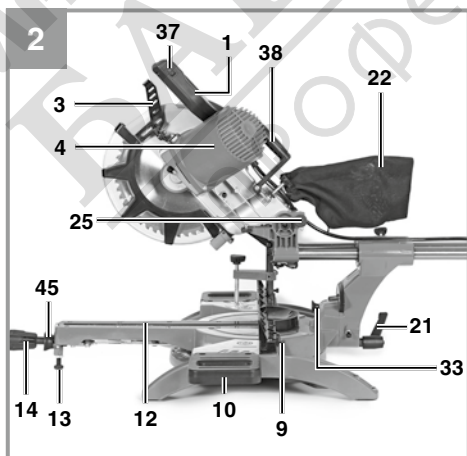
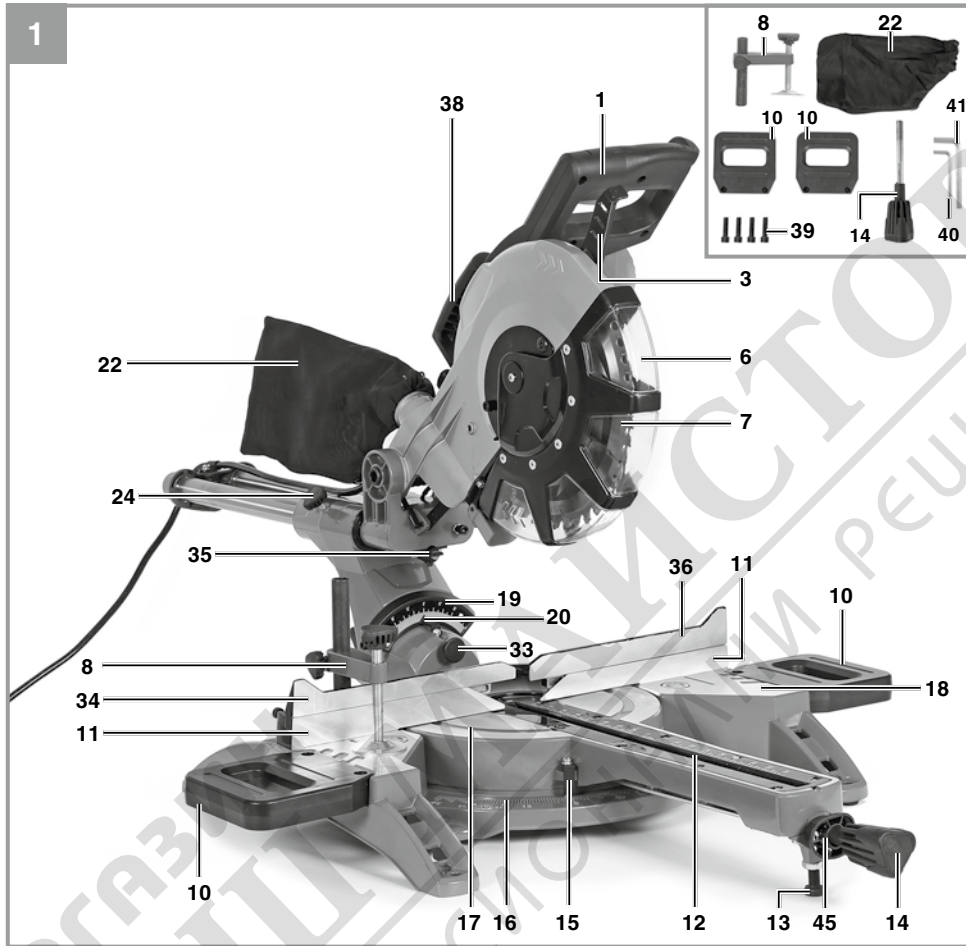

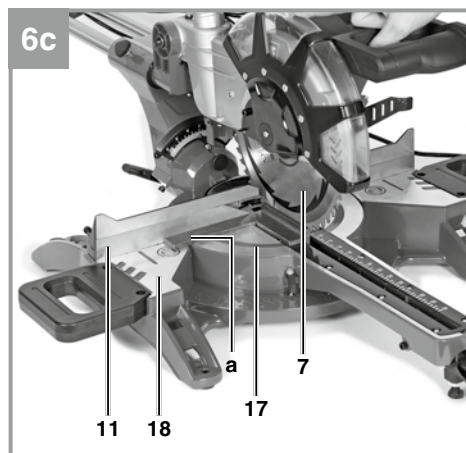
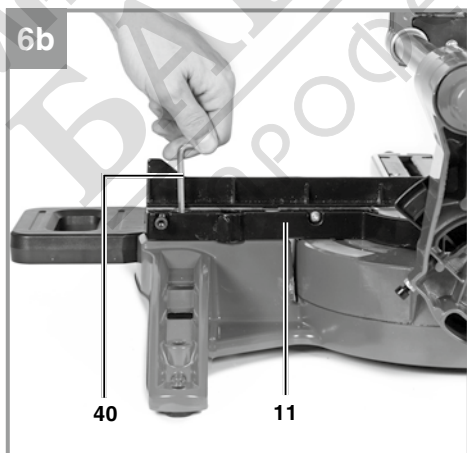
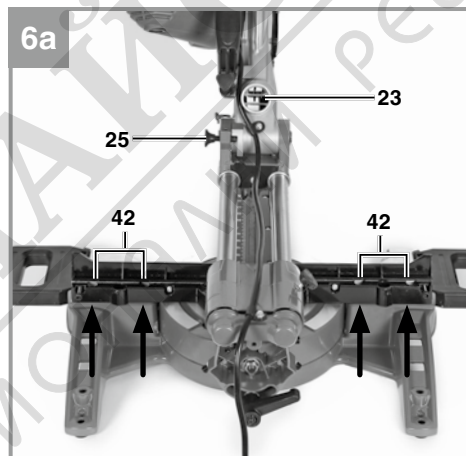
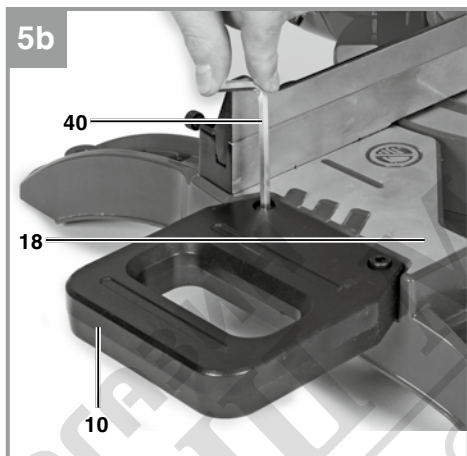
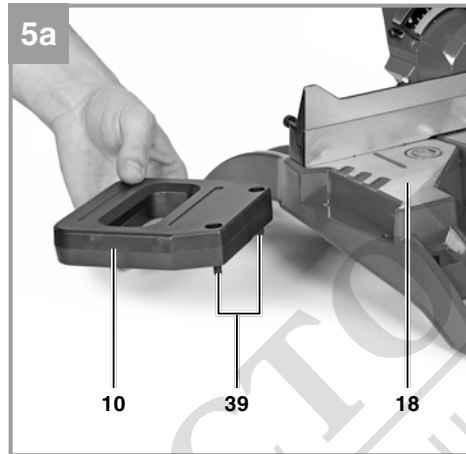
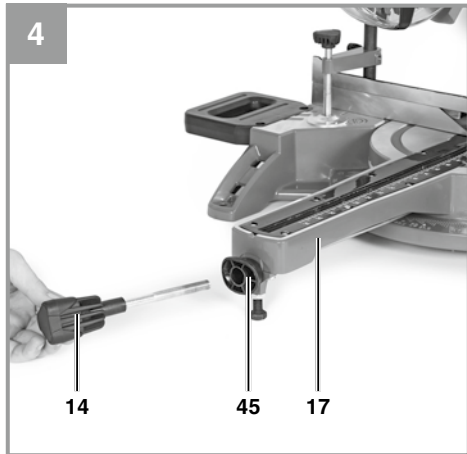

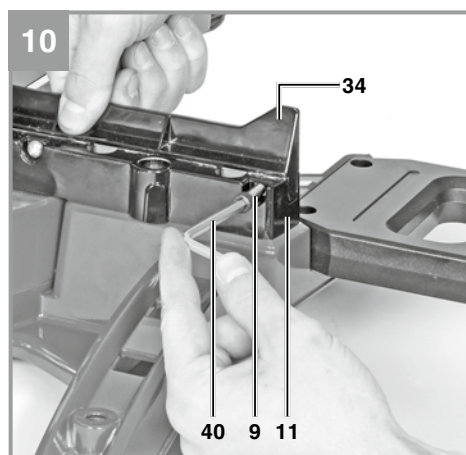
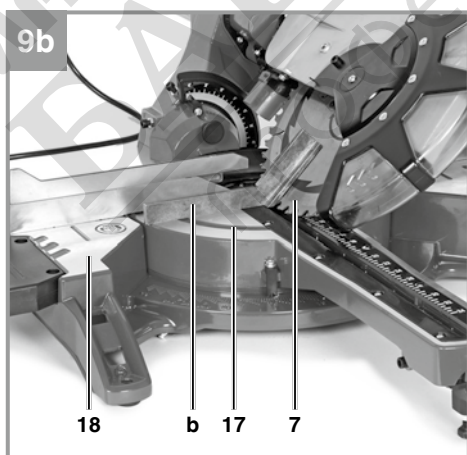
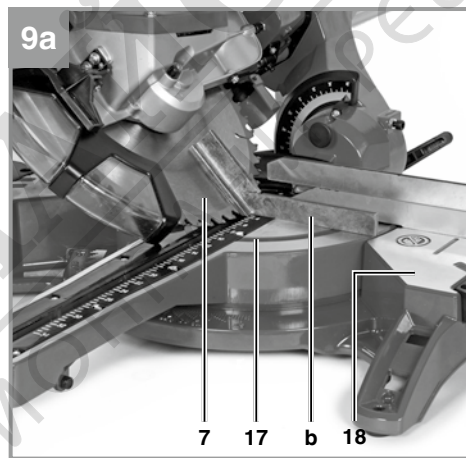
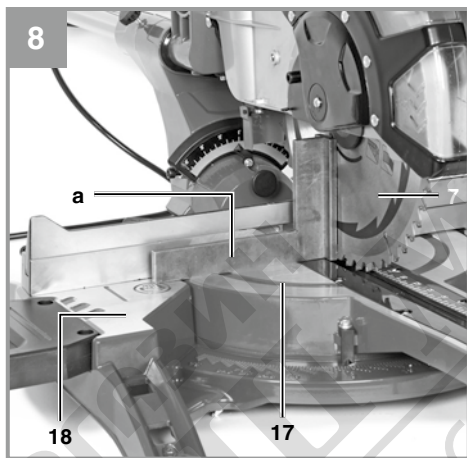
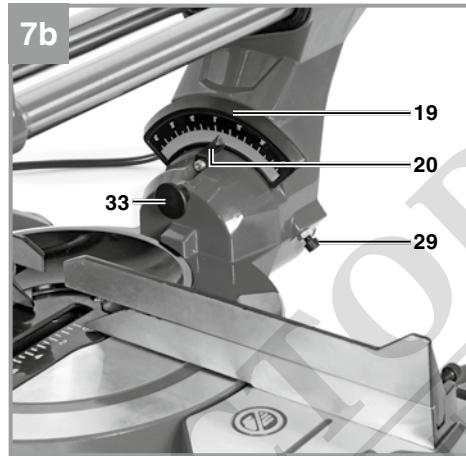
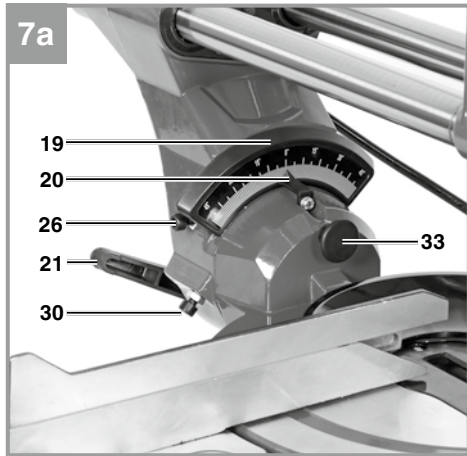

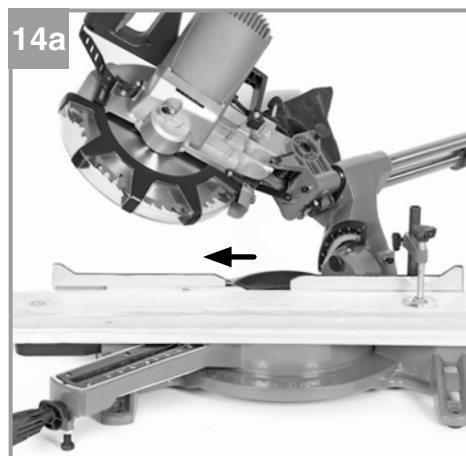
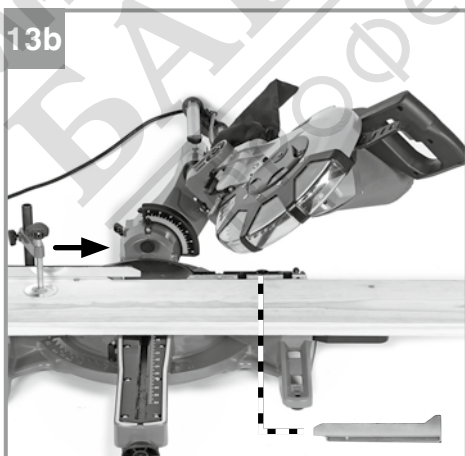
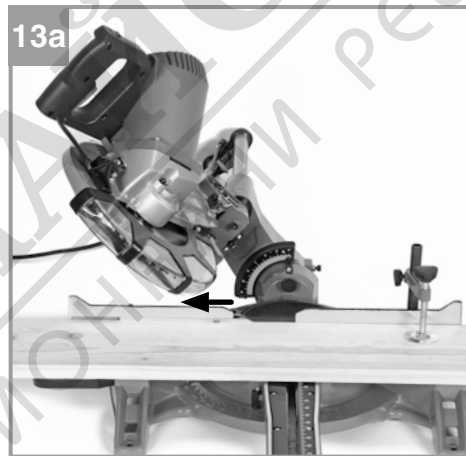
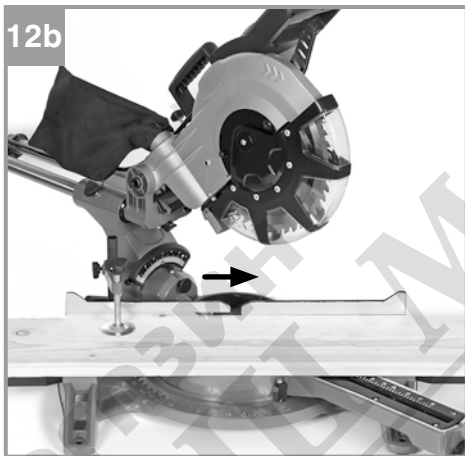
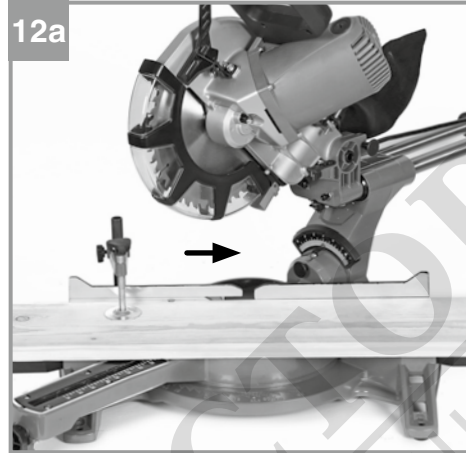
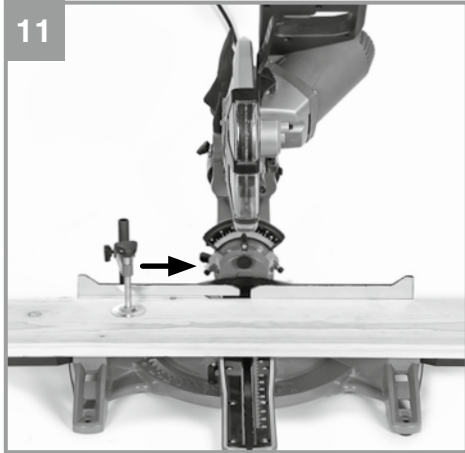

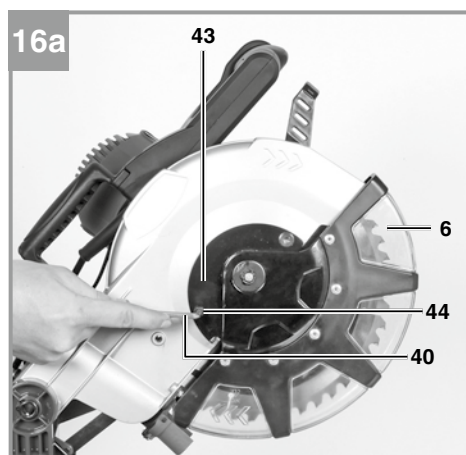
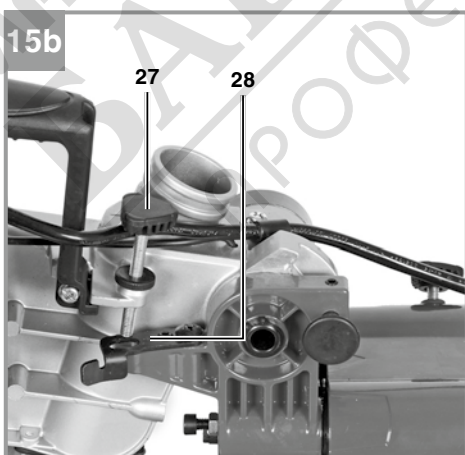
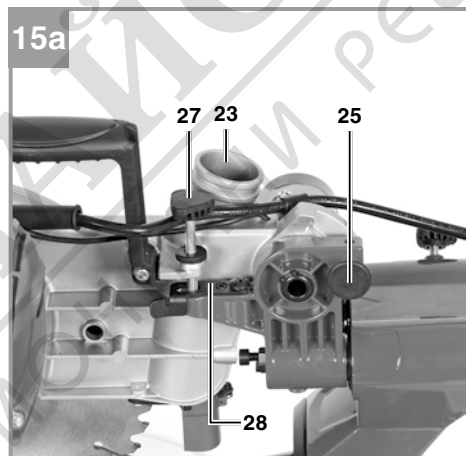
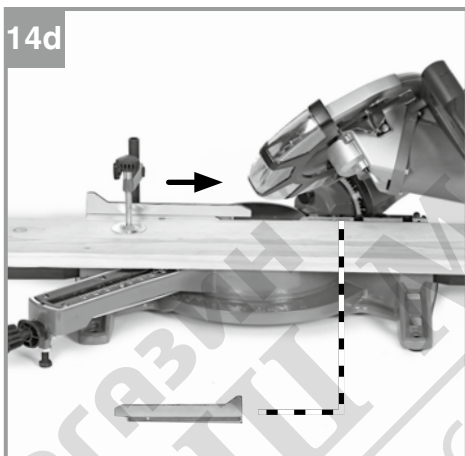
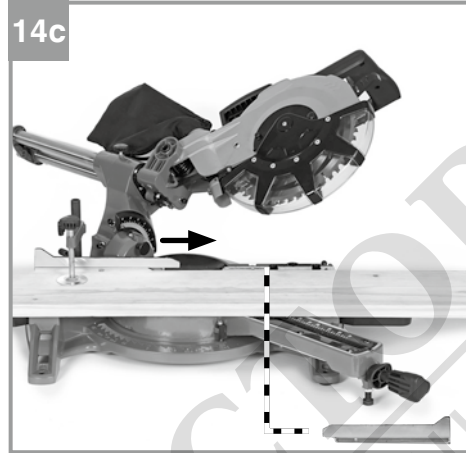
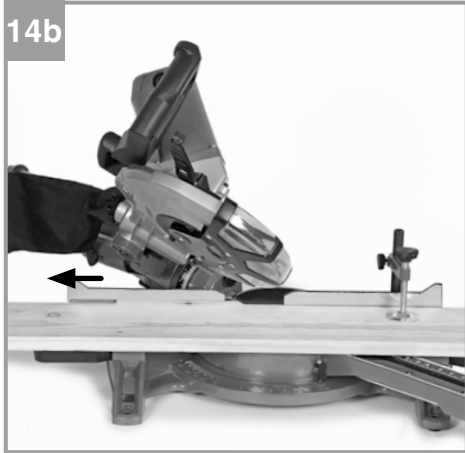

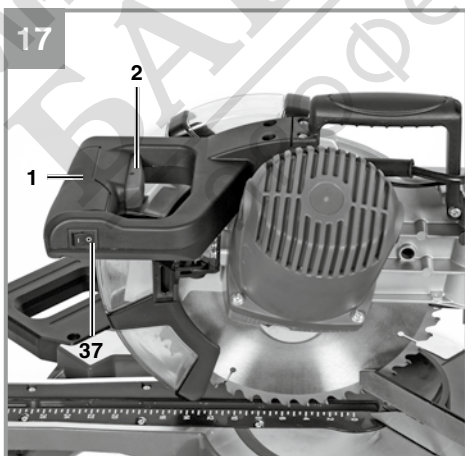
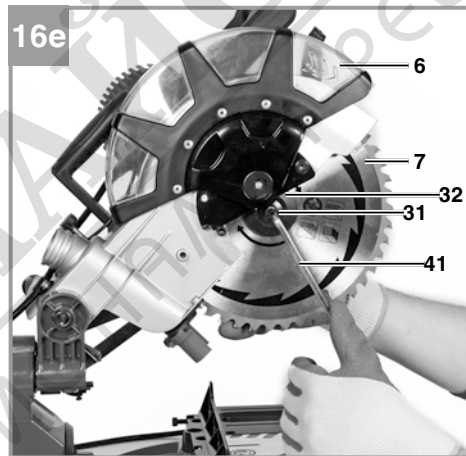
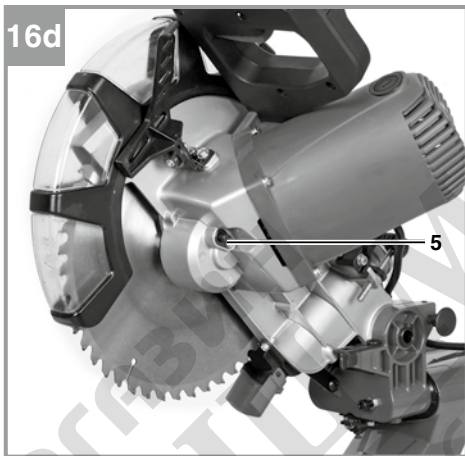
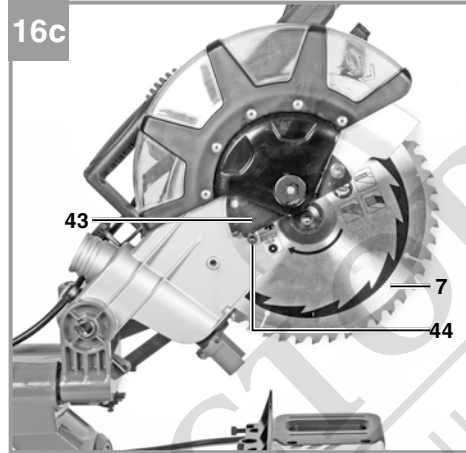
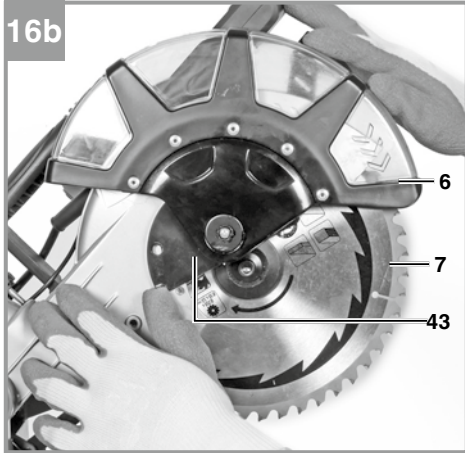

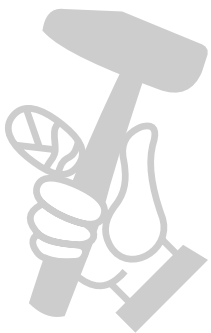
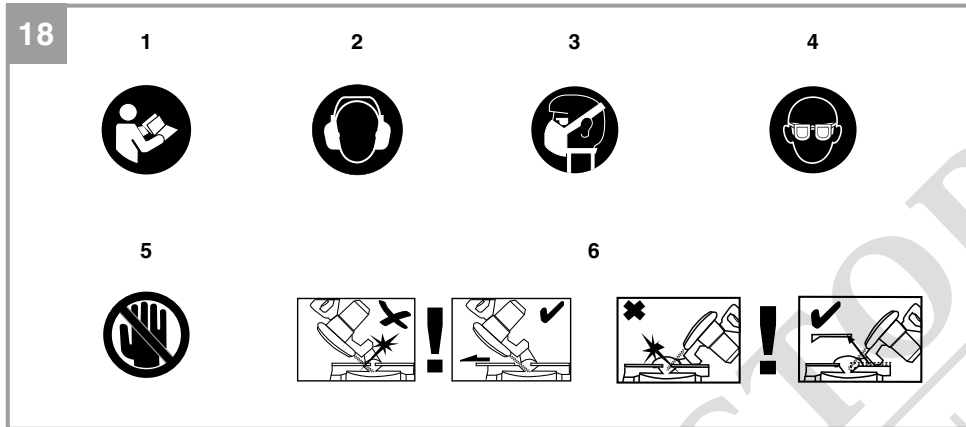

Danger!

When using the equipment, a few safety precautions must be observed to avoid injuries and damage. Please read the complete operating instructions and safety regulations with due care. Keep this manual in a safe place, so that the information is available at all times. If you give the equipment to any other person, hand over these operating instructions and safety regulations as well. We cannot accept any liability for damage or accidents which arise due to a failure to follow these instructions and the safety instructions.

Explanation of the symbols used (see Fig. 18)

1. **Danger!** - Read the operating instructions to reduce the risk of injury
2. **Caution! Wear ear-muffs.** The impact of noise can cause damage to hearing.
3. **Caution! Wear a breathing mask.** Dust which is injurious to health can be generated when working on wood and other materials. Never use the device to work on any materials containing asbestos!
4. **Caution! Wear safety goggles.** Sparks generated during working or splinters, chips and dust emitted by the device can cause loss of sight.
5. **Caution! Risk of injury!** Do not reach into the running saw blade.
6. **Warning!** The adjustable stop rails are secured by hex screws.
To make miter cuts (with the saw head inclined or the turntable set at an angle), the adjustable stop rails must be fixed at an outer position.
For 45° crosscuts to the left, the left stop rail must be pushed outwards and screwed tight.
For 45° crosscuts to the right, the right-hand removable stop rail must be removed in upwards direction.
To make 90° crosscuts, the adjustable stops rail must be fixed at the inner position!

1. Safety regulations

The corresponding safety information can be found in the enclosed booklet.

Warning!

Read all the safety information, instructions, illustrations and technical data provided on or with this power tool. Failure to adhere to the following instructions may result in electric shock, fire and/or serious injury.

Keep all the safety information and instructions in a safe place for future use.

Special information about the laser

⚠ Caution! Laser radiation
Do not look into the beam
Laser class 2



- Never look directly into the laser path.
- Never direct the laser beam at reflecting surfaces or persons or animals. Even a low output laser beam can inflict injury on the eye.
- Caution: It is vital to follow the work procedures described in these instructions. Using the equipment in any other way may result in hazardous exposure to laser radiation.
- Never open the laser module.
- It is prohibited to carry out any modifications to the laser to increase its power.
- The manufacturer cannot accept any liability for damage due to non-observance of the safety information.

2. Layout and items supplied**2.1 Layout (Fig. 1-17)**

1. Handle
2. On/Off switch
3. Release lever
4. Machine head
5. Saw shaft lock
6. Adjustable blade guard
7. Saw blade
8. Clamping device
9. Locking screw for stop rail
10. Workpiece support
11. Fixed stop rail
12. Table insert
13. Adjustable foot
14. Locking screw
15. Pointer (turntable)
16. Scale (turntable)
17. Turntable

18. Fixed saw table
19. Scale (miter)
20. Pointer (miter)
21. Locking lever
22. Sawdust bag
23. Discharge opening
24. Locking screw for drag guide
25. Retaining pin
26. Adjustment screw for stop 90°
27. Knurled screw for cutting depth limiter
28. Stop for cutting depth limiter
29. Adjustment screw for stop 45° to the left
30. Adjustment screw for stop 45° to the right
31. Flange bolt
32. Outer flange
33. Button
34. Adjustable stop rail
35. Laser
36. Removable stop rail
37. On/Off switch for laser
38. Transport handle
39. Socket head screw 5mm for workpiece support
40. Hex key 5mm
41. Hex key 6mm
42. Adjustment screw for stop rail
43. Cover plate
44. Screw for cover
45. Knob for adjusting the turntable

2.2 Items supplied

Please check that the article is complete as specified in the scope of delivery. If parts are missing, please contact our service center or the sales outlet where you made your purchase at the latest within 5 working days after purchasing the product and upon presentation of a valid bill of purchase. Also, refer to the warranty table in the service information at the end of the operating instructions.

- Open the packaging and take out the equipment with care.
- Remove the packaging material and any packaging and/or transportation braces (if available).
- Check to see if all items are supplied.
- Inspect the equipment and accessories for transport damage.
- If possible, please keep the packaging until the end of the guarantee period.

Danger!

The equipment and packaging material are not toys. Do not let children play with plastic bags, foils or small parts. There is a danger of swallowing or suffocating!

- Drag, crosscut and miter saw
- Clamping device
- Workpiece support (2x)
- Locking screw
- Sawdust bag
- Socket head screw 5mm for workpiece support (4x)
- Hex key 5mm
- Hex key 6mm
- Original operating instructions
- Safety instructions

3. Proper use

The drag, crosscut and miter saw is designed for cross-cutting wood and wood-type materials which are appropriate for the machine's size. The saw is not designed for cutting firewood.

The equipment is to be used only for its prescribed purpose. Any other use is deemed to be a case of misuse. The user / operator and not the manufacturer will be liable for any damage or injuries of any kind caused as a result of this.

Please note that our equipment has not been designed for use in commercial, trade or industrial applications. Our warranty will be voided if the machine is used in commercial, trade or industrial businesses or for equivalent purposes.

The equipment is to be operated only with suitable saw blades. It is prohibited to use any type of cutting-off wheel.

To use the equipment properly you must also observe the safety information, the assembly instructions and the operating instructions to be found in this manual.

All persons who use and service the equipment have to be acquainted with these operating instructions and must be informed about the equipment's potential hazards. It is also imperative to observe the accident prevention regulations in force in your area. The same applies for the general rules of health and safety at work.

The manufacturer will not be liable for any chan-

ges made to the equipment nor for any damage resulting from such changes. Even when the equipment is used as prescribed it is still impossible to eliminate certain residual risk factors. The following hazards may arise in connection with the machine's construction and design:

- Contact with the saw blade in the uncovered saw zone.
- Reaching into the running saw blade (cut injuries).
- Kick-back of workpieces and parts of workpieces.
- Saw blade fracturing.
- Catapulting of faulty carbide tips from the saw blade.
- Damage to hearing if ear-muffs are not used as necessary.
- Harmful emissions of wood dust when used in closed rooms.

4. Technical data

AC motor:	230-240 V~ 50Hz
Power:	2100 W S1 / 2350 W S6 25%
Idle speed n_0 :	4000 min ⁻¹
Carbide saw blade:	∅ 250 x ∅ 30 x 3.0 mm
Maximum tooth pitch:	3.2 mm
Number of teeth:	48
Swiveling range:	-47° / 0° / +47°
Miter cut to the left:	0° to 45°
Miter cut to the right:	0° to 45°
Saw width at 90°:	340 x 75 mm
Saw width at 45°:	240 x 75 mm
Saw width at 2 x 45° (double miter cut left):	240 x 42 mm
Saw width at 2 x 45° (double miter cut right):	240 x 25 mm
Weight:	approx. 16 kg
Laser class:	2
Wavelength of laser:	650 nm
Laser output:	≤ 1 mW
Protection class:	II/□

Minimum workpiece size: Only ever cut workpieces which are big enough to clamp securely with the clamping device – minimum length 180 mm.

Operating mode S6 25%: Continuous operation with idling (cycle time 10 minutes). To ensure that the motor does not become excessively hot, it may only be operated for 25% of the cycle at the

specified rating and must then be allowed to idle for 75% of the cycle.

Danger! Noise

The noise emission values were measured in accordance with EN 62841.

Operation

L_{pA} sound pressure level	96 dB(A)
K_{pA} uncertainty	3 dB(A)
L_{WA} sound power level	109 dB(A)
K_{WA} uncertainty	3 dB(A)

Wear ear-muffs.

The impact of noise can cause damage to hearing.

The stated noise emission values were measured in accordance with a set of standardized criteria and can be used to compare one power tool with another.

The stated noise emission values can also be used to make an initial assessment of exposure.

Warning:

The noise emission levels may vary from the level specified during actual use, depending on the way in which the power tool is used, especially the type of workpiece it is used for.

Keep the noise emissions and vibrations to a minimum.

- Only use appliances which are in perfect working order.
- Service and clean the appliance regularly.
- Adapt your working style to suit the appliance.
- Do not overload the appliance.
- Have the appliance serviced whenever necessary.
- Switch the appliance off when it is not in use.

Caution!

Residual risks

Even if you use this electric power tool in accordance with instructions, certain residual risks cannot be ruled out. The following hazards may arise in connection with the equipment's construction and layout:

1. Lung damage if no suitable protective dust mask is used.
2. Damage to hearing if no suitable ear protection is used.

- Health damage caused by hand-arm vibrations if the equipment is used over a prolonged period or is not properly guided and maintained.

5. Before starting the equipment

Before you connect the equipment to the mains supply make sure that the data on the rating plate are identical to the mains data.

Warning!

Always pull the power plug before making adjustments to the equipment.

5.1 General information

- The equipment must be set up where it can stand securely, i.e. it should be bolted to a workbench, a universal base frame or similar.
- All covers and safety devices have to be properly fitted before the equipment is switched on.
- It must be possible for the blade to run freely.
- When working with wood that has been processed before, watch out for foreign bodies such as nails or screws, etc.
- Before you actuate the On/Off switch, make sure that the saw blade is correctly fitted and that the equipment's moving parts run smoothly.

5.2 Assembling the saw (Fig. 1-5)

- Fit to the locking screw (14) to the turntable (17).
- Fit the workpiece supports (10) on the left and on the right of the fixed saw table (18). Do this with the socket head screws (39) and the 5mm hex key (40).
- To fit the sawdust bag (22) to the discharge opening (23) on the crosscut saw, spread the metal ring apart on the opening. When the metal ring is back in its original shape, the sawdust bag is held securely in position.
- The clamping device (8) can be fitted on the left or right of the fixed saw table (18).

5.3 Adjusting the saw (Fig. 1-3)

- To adjust the turntable (17), loosen the locking screw (14) by approx. 2 turns, which frees the turntable (17).
- Pull on the knob (45) to release the turntable (17) from a locked position. Keep holding the knob (45) pulled out until the turntable (17) is at the required angular setting.

- Turn the turntable (17) and scale pointer (15) to the desired angular setting on the dial (16) and lock into place with the locking screw (14). The saw has locking positions at angles of -45°, -31.6°, -22.5°, -15°, 0°, 15°, 22.5°, 31.6° and 45°, at which the turntable (17) audibly clicks into position.
- To release the saw from its position at the bottom, pull the retaining pin (25) out of the motor mounting while pressing down lightly on the machine head (4).
- Swing the machine head (4) up until the release lever (3) latches into place.
- To adjust the machine head (4) for a miter cut, slacken the locking lever (21).
- Then you can tilt the machine head (4) to the left by up to 45°. After the desired angular setting has been set on the scale pointer (20) on the scale (19), secure the machine head (4) again with the locking lever (21).
- To tilt the machine head to the right by up to 45°, proceed as follows:
 - Tilt the machine head (4) by approx. 10° to the left.
 - Pull out and hold the button (33).
 - Swing the machine head (4) over the 0° line to the right.
 - After reaching approx. 10° on the right-hand side, let go of the button (33).
 - When the pointer (20) reaches the desired angular setting on the scale (19), secure the machine head (4) again with the locking lever (21).
- To return the machine head to 0° on the scale (19) there is no need to press the button (33) again.
- To ensure that the saw is standing securely, adjust the adjustable foot (13) by turning it so that the saw stands in a horizontal and firm position.

5.4 Precision adjustment of the stop rail (Fig. 6)

- Lower the machine head (4) and fasten in place with the retaining pin (25).
- Fasten the turntable (17) in 0° position.
- Place the 90° stop angle (a) between the blade (7) and the stop rail (11).
- Slacken the four adjustment screws (42) using the 5mm hex key (40), set the stop rail (11) to 90° in relation to the saw blade (7) and retighten the adjustment screws (42).
- There is no angle stop (a) included the scope of this delivery.

5.5 Precision adjustment of the stop for crosscut 90° (Fig. 7a, 8)

- Fasten the turntable (17) in 0° position.
- Slacken the locking lever (21) and tilt the machine head (4) to 0° using the handle (1).
- Place the 90° angular stop (a) between the blade (7) and the turntable (17).
- Adjust the adjustment screw (26) until the angle between the blade (7) and the turntable (17) equals 90°.
- Finally, check the position of the pointer (20) on the scale (19).
- If necessary, release the pointer (20) with a crosstip screwdriver, move to the 0° position of the scale (19) and retighten the holding screw.
- The angle stop (a) and crosstip screwdriver are not included in the scope of this delivery.

5.6 Precision adjustment of the stop for miter cut 45° (Fig. 7, 9)

- Lower the machine head (4) and fasten in place with the retaining pin (25).
- Fasten the turntable (17) in 0° position.
- Undo the locking lever (21) and move the machine head (4) all the way to the left using the handle (1), until it coincides at 45°.
- Place the 45° stop angle (b) between the blade (7) and the turntable (17).
- Adjust the adjustment screw (29) so that the angle between the blade (7) and the turntable (17) equals exactly 45°.
- To set the stop 45° on the right-hand side: Tilt the machine head (4) to the right (see section 5.3) and set the adjustment screw (30) according to the left-hand side.
- No angle stop (b) included.

6. Operation

Warning! To make 90° crosscuts, the adjustable stop rail (34) must be fixed at the inner position:

- Undo the locking screw (9) of the adjustable stop rail and push the adjustable stop rail inwards.
- The adjustable stop rail (34) must be fixed far enough in front of the innermost position that the distance between the stop rail (34) and the saw blade (7) amounts to a maximum of 8 mm.
- Before making a cut, check that the stop rail and the saw blade cannot collide.
- Tighten the locking screw (9) again.

Warning! To make 0°-45° miter cuts to the left (with the machine head (4) inclined or with the turntable set at an angle), the adjustable stop rail (34) must be fixed at an outer position.

- Undo the locking screw (9) of the adjustable stop rail and push the adjustable stop rail outwards.
- The adjustable stop rail (34) must be fixed far enough in front of the innermost position that the distance between the stop rail (34) and the saw blade (7) amounts to a maximum of 8 mm.
- Before making a cut, check that the stop rail and the saw blade cannot collide.
- Tighten the locking screw (9) again.

Warning! This saw is equipped with a removable stop rail (36) which is screwed to the right-hand side of the fixed stop rail (11).

To make 0°-45° miter cuts to the right (with the machine head (4) inclined or with the turntable set at an angle), the removable stop rail (36) must be completely removed. **Warning!** In this case the maximum permissible workpiece height is reduced (see 4. Technical data).

- Open the locking screw (9) of the removable stop rail (36) far enough for you to be able to remove the stop rail (36) in upwards direction.
- Always fasten the removable stop rail (36) on the equipment again after you have completed your work.
- The stop rail must always be kept together with the equipment. A removed stop rail will impair the operational safety of the equipment.

6.1 Cross cut 90° and turntable 0° (Fig. 1-3, 11)

For cutting widths up to approx. 100 mm it is possible to fix the saw's drag function with the locking screw for drag guide (24) in rear position. If the cutting width exceeds 100 mm you must ensure that the locking screw for drag guide (24) is slackened and that the machine head (4) can be moved.

- Move the machine head (4) to its upper position.
- Use the handle (1) to push back the machine head (4) and fix it in this position if required (dependent on the cutting width).
- Place the piece of wood to be cut at the stop rail (11) and on the turntable (17).
- Lock the material with the clamping device (8) on the fixed saw table (18) to prevent the material from moving during the cutting operation.

- ration.
- Push down the release lever (3) to release the machine head (4).
- Press the On/Off switch (2) to start the motor.
- With the drag guide fixed in place: Use the handle (1) to move the machine head (4) steadily and with light pressure downwards until the saw blade (7) has completely cut through the workpiece.
- With the drag guide not fixed in place: Pull the machine head (4) all the way to the front and then use the handle (1) to move it downwards steadily and with light pressure. Now push the machine head (4) slowly and steadily to the very back until the saw blade (7) has completely cut through the workpiece.
- When the cutting operation is completed, move the machine head (4) back to its upper (home) position and release the On/Off button (2).

Important! The integral resetting springs will automatically lift the machine head. Do not simply let go of the handle (1) after cutting, but allow the machine head (4) to rise slowly, applying slight counter pressure as it does so.

6.2 Cross cut 90° and turntable 0° - 45° (Fig. 1-3, 12)

The crosscut saw can be used to make crosscuts of 0°- 45° to the left and 0° - 45° to the right in relation to the stop rail.

- Release the turntable (17) by undoing the locking screw (14).
- Turn the turntable (17) and scale pointer (15) to the desired angular setting on the dial (16) and lock into place with the locking screw (14). The saw has locking positions at angles of - 45°, -31.6°, -22.5°, -15°, 0°, 15°, 22.5°, 31.6° and 45°, at which the turntable (17) audibly clicks into position.
- Retighten the locking screw (14) to secure the turntable (17) in place.
- Cut as described in section 6.1.

6.3 Miter cut 0°- 45° and turntable 0° (Fig. 1-3, 13)

The crosscut saw can be used to make miter cuts to the left of 0°-45° and to the right of 0°-45° in relation to the work surface.

- If required, dismantle the clamping device (8) or mount it on the opposite side of the fixed saw table (18).
- Move the machine head (4) to its upper position.
- Fasten the turntable (17) in 0° position.

- Adjust the miter angle on the machine head as described in section 5.3.
- Cut as described in section 6.1.

6.4 Miter cut 0°- 45° and turntable 0°- 45° (Fig. 1-3, 14)

The crosscut saw can be used to make miter cuts to the left of 0°-45° and to the right of 0°-45° in relation to the work surface, with simultaneous setting of the turntable from 0°-45° to the left or 0°-45° to the right in relation to the stop rail (double miter cut).

- If required, dismantle the clamping device (8) or mount it on the opposite side of the fixed saw table (18).
- Move the machine head (4) to its upper position.
- Release the turntable (17) by undoing the locking screw (14).
- Use the handle (1) to adjust the turntable (17) to the angle required (in this connection see also section 6.2).
- Retighten the locking screw (14) to secure the turntable in place.
- Adjust the miter angle on the machine head as described in section 5.3.
- Cut as described in section 6.1.

6.5 Limiting the cutting depth (Fig. 15)

- If the stop (28) is aligned parallel to the saw blade (4), the cutting depth limiter will be deactivated.
- To activate the cutting depth limiter, the stop (28) must be swung to the right.
- The cutting depth can be infinitely adjusted using the screw (27). Turn the screw (27) in or out to set the required cutting depth and then retighten the knurled nut on the screw (27).
- Check the setting by completing a test cut.

6.6 Sawdust bag (Fig. 2)

The saw is equipped with a sawdust bag (22) for sawdust and chips.

The sawdust bag (22) can be emptied by means of a zipper at the bottom.

6.7 Replacing the saw blade (Fig. 1, 16)

- **Warning!** Before changing the saw blade: Pull out the power plug!
- **Caution!** Wear work gloves to prevent injury when changing the saw blade.
- Swing the machine head upwards (4).
- Undo the screw (44) on the cover plate (43) of the saw blade.
- Pull back the adjustable blade guard (6) and

at the same time turn the cover plate to achieve access to the flange bolt.

- Push up the cover plate (43) far enough for you to be able to screw in the screw (44) again by approx. 5 turns. The flange bolt (31) is now accessible for changing the saw blade.
- Press the saw shaft lock (5) with one hand while positioning the hexagon key 6mm (41) on the flange bolt (31) with the other hand. The saw shaft lock (5) engages after no more than one rotation.
- Now, using a little more force, slacken the flange screw (31) in the clockwise direction.
- Turn the flange screw (31) right out and remove the external flange (32).
- Take the blade (7) off the inner flange and pull out downwards.
- Carefully clean the flange screw (31), outer flange (32) and inner flange.
- Fit and fasten the new saw blade (7) in reverse order.
- **Caution!** The cutting angle of the teeth, in other words the direction of rotation of the saw blade (7) must coincide with the direction of the arrow on the housing.
- Finally, the screw (44) and the cover plate (43) must be screwed tight again in bottom position.
- **Warning!** Check that the safety devices are in good working condition before you fit the power plug again.
- **Warning!** Every time that you change the saw blade, check that the saw blade guard (6) opens and closes again in accordance with requirements. Also check that the saw blade (7) spins freely in the saw blade guard (6).
- **Warning!** Every time that you change the saw blade, check to see that it spins freely in the table insert (12) in both perpendicular and 45° angle settings.
- **Warning!** You should replace the table insert (12) immediately whenever it is worn or damaged. To do so, undo the Philips screws in the table insert (12) and take the table insert out of the fixed saw table (18). To fit the new table insert (12), proceed in reverse order.
- **Warning!** The work to change and align the saw blade (7) must be carried out correctly.

6.8 Transport (Fig. 1-3)

- Retighten the locking screw (14) to secure the turntable (17) in place.
- Activate the release lever (3), press the machine head (4) downwards and secure with

the safety pin (25). The saw is now locked in its bottom position.

- Fix the saw's drag function with the locking screw for drag guide (24) in rear position.
- Carry the equipment by the fixed saw table (18).
- To set up the equipment again, proceed as described in section 5.2, 5.3.

6.9 Operating the laser (Fig. 1, 17)

Switching on: Move the On/Off switch (37) to the "I" position to switch on the laser (35). A laser line is projected onto the material you wish to process, providing an exact guide for the cut.

Switching off: Move the On/Off switch (37) to the "0" position.

6.10 Electric brake

For safety reasons, the equipment is supplied with an electric brake system for the saw blade. The equipment may therefore emit an odor or generate sparks when it is switched off. This has no influence on the operational performance or safety of the equipment.

7. Replacing the power cable

Danger!

If the power cable for this equipment is damaged, it must be replaced by the manufacturer or its after-sales service or similarly trained personnel to avoid danger.

8. Cleaning, maintenance and ordering of spare parts

Danger!

Always pull out the mains power plug before starting any cleaning work.

8.1 Cleaning

- Keep all safety devices, air vents and the motor housing free of dirt and dust as far as possible. Wipe the equipment with a clean cloth or blow it with compressed air at low pressure.
- We recommend that you clean the device immediately each time you have finished using it.
- Clean the equipment regularly with a moist cloth and some soft soap. Do not use cleaning agents or solvents; these could at-

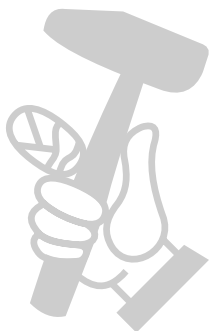

tack the plastic parts of the equipment. Ensure that no water can seep into the device. The ingress of water into an electric tool increases the risk of an electric shock.

8.2 Carbon brushes

In case of excessive sparking, have the carbon brushes checked only by a qualified electrician. Important! The carbon brushes should not be replaced by anyone but a qualified electrician.

8.3 Maintenance

There are no parts inside the equipment which require additional maintenance.

8.4 Ordering spare parts and accessories

Please provide the following information when ordering spare parts:

- Type of unit
- Article number of the unit
- ID number of the unit
- Spare part number of the required spare part

For our latest prices and information please go to www.Einhell-Service.com



Tip! For good results we recommend high-quality accessories from **kwb** !
www.kwb.eu
welcome@kwb.eu

9. Disposal and recycling

The equipment is supplied in packaging to prevent it from being damaged in transit. The raw materials in this packaging can be reused or recycled. The equipment and its accessories are made of various types of material, such as metal and plastic. Never place defective equipment in your household refuse. The equipment should be taken to a suitable collection center for proper disposal. If you do not know the whereabouts of such a collection point, you should ask in your local council offices.

10. Storage

Store the equipment and accessories out of children's reach in a dark and dry place at above freezing temperature. The ideal storage temperature is between 5 and 30 °C. Store the electric tool in its original packaging.



For EU countries only

Never place any electric power tools in your household refuse.

To comply with European Directive 2012/19/EC concerning old electric and electronic equipment and its implementation in national laws, old electric power tools have to be separated from other waste and disposed of in an environment-friendly fashion, e.g. by taking to a recycling depot.

Recycling alternative to the return request:

As an alternative to returning the equipment to the manufacturer, the owner of the electrical equipment must make sure that the equipment is properly disposed of if he no longer wants to keep the equipment. The old equipment can be returned to a suitable collection point that will dispose of the equipment in accordance with the national recycling and waste disposal regulations. This does not apply to any accessories or aids without electrical components supplied with the old equipment.

Please note that batteries and lamps (e.g. light bulbs) must be removed from the tool before it is disposed of.

The reprinting or reproduction by any other means, in whole or in part, of documentation and papers accompanying products is permitted only with the express consent of the Einhell Germany AG.

Subject to technical changes

- The product meets the requirements of EN 61000-3-11 and is subject to special connection conditions. This means that use of the product at any freely selectable connection point is not allowed.
- Given unfavorable conditions in the power supply the product can cause the voltage to fluctuate temporarily.
- The product is intended solely for use at connection points that
 - a) do not exceed a maximum permitted mains system impedance of $Z_{max} = 0,346\Omega$, or
 - b) have a continuous current-carrying capacity of the mains of at least 100 A per phase.
- As the user, you are required to ensure, in consultation with your electric power company if necessary, that the connection point at which you wish to operate the product meets one of the two requirements, a) or b), named above.

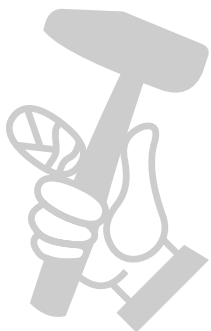

Service information

We have competent service partners in all countries named on the guarantee certificate whose contact details can also be found on the guarantee certificate. These partners will help you with all service requests such as repairs, spare and wearing part orders or the purchase of consumables.

Please note that the following parts of this product are subject to normal or natural wear and that the following parts are therefore also required for use as consumables.

Category	Example
Wear parts*	Carbon brushes
Consumables*	Saw blade
Missing parts	

* Not necessarily included in the scope of delivery!

In the event of defects or faults, please register the problem on the internet at www.Einhell-Service.com. Please ensure that you provide a precise description of the problem and answer the following questions in all cases:

- Did the equipment work at all or was it defective from the beginning?
- Did you notice anything (symptom or defect) prior to the failure?
- What malfunction does the equipment have in your opinion (main symptom)? Describe this malfunction.

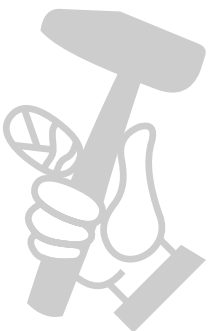

Warranty certificate

Dear Customer,

All of our products undergo strict quality checks to ensure that they reach you in perfect condition. In the unlikely event that your device develops a fault, please contact our service department at the address shown on this guarantee card. You can also contact us by telephone using the service number shown. Please note the following terms under which guarantee claims can be made:

1. These guarantee terms apply to consumers only, i.e. natural persons intending to use this product neither for their commercial activities nor for any other self-employed activities. These warranty terms regulate additional warranty services, which the manufacturer mentioned below promises to buyers of its new products in addition to their statutory rights of guarantee. Your statutory guarantee claims are not affected by this guarantee. Our guarantee is free of charge to you.
2. The warranty services cover only defects due to material or manufacturing faults on a product which you have bought from the manufacturer mentioned below and are limited to either the rectification of said defects on the product or the replacement of the product, whichever we prefer.
Please note that our devices are not designed for use in commercial, trade or professional applications. A guarantee contract will not be created if the device has been used by commercial, trade or industrial business or has been exposed to similar stresses during the guarantee period.
3. The following are not covered by our guarantee:
 - Damage to the device caused by a failure to follow the assembly instructions or due to incorrect installation, a failure to follow the operating instructions (for example connecting it to an incorrect mains voltage or current type) or a failure to follow the maintenance and safety instructions or by exposing the device to abnormal environmental conditions or by lack of care and maintenance.
 - Damage to the device caused by abuse or incorrect use (for example overloading the device or the use of unapproved tools or accessories), ingress of foreign bodies into the device (such as sand, stones or dust, transport damage), the use of force or damage caused by external forces (for example by dropping it).
 - Damage to the device or parts of the device caused by normal or natural wear or tear or by normal use of the device.
4. The guarantee is valid for a period of 24 months starting from the purchase date of the device. Guarantee claims should be submitted before the end of the guarantee period within two weeks of the defect being noticed. No guarantee claims will be accepted after the end of the guarantee period. The original guarantee period remains applicable to the device even if repairs are carried out or parts are replaced. In such cases, the work performed or parts fitted will not result in an extension of the guarantee period, and no new guarantee will become active for the work performed or parts fitted. This also applies if an on-site service is used.
5. To make a claim under the guarantee, please register the defective device at: www.Einhell-Service.com. Please keep your bill of purchase or other proof of purchase for the new device. Devices that are returned without proof of purchase or without a rating plate shall not be covered by the guarantee, because appropriate identification will not be possible. If the defect is covered by our guarantee, then the item in question will either be repaired immediately and returned to you or we will send you a new replacement.

Of course, we are also happy offer a chargeable repair service for any defects which are not covered by the scope of this guarantee or for units which are no longer covered. To take advantage of this service, please send the device to our service address.

Also refer to the restrictions of this warranty concerning wear parts, consumables and missing parts as set out in the service information in these operating instructions.

