



Husqvarna®



333R Mark II, 333RB Mark II

EN	Operator's manual	10-25
ES	Manual de usuario	26-42
IT	Manuale dell'operatore	43-60
TR	Kullanım kılavuzu	61-76



МАГАЗИН МАЙСТОРА
ПРОФЕСІОНАЛНИ РЕШЕННЯ

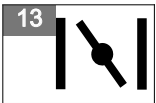
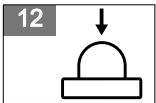
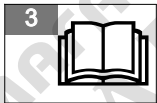
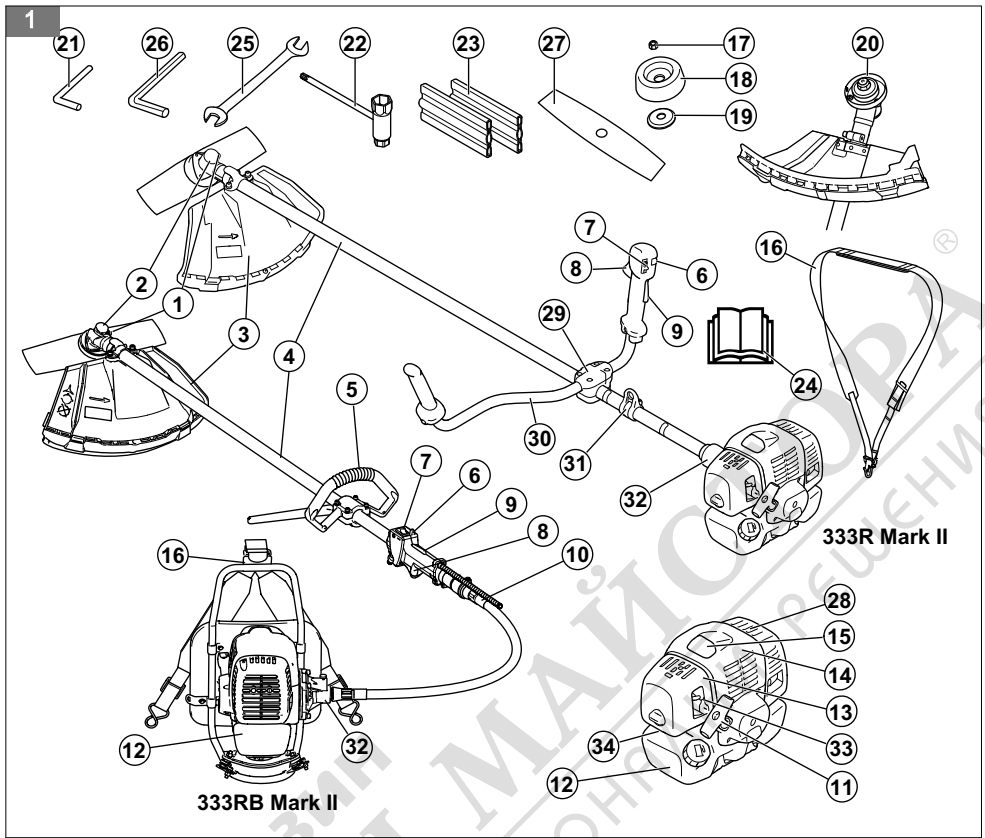

16



17



18

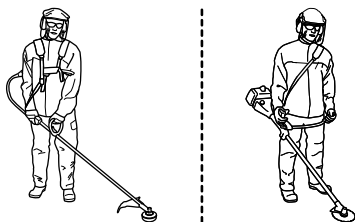

19

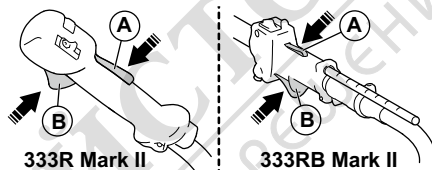

20

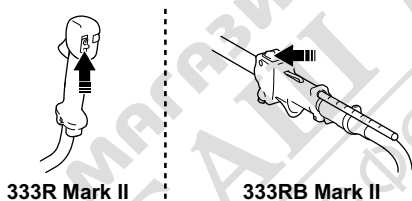

21

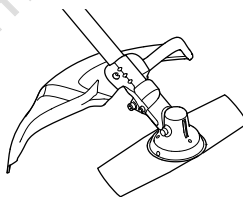

22

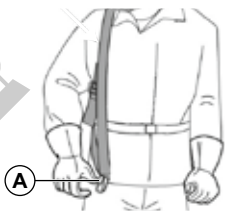

23

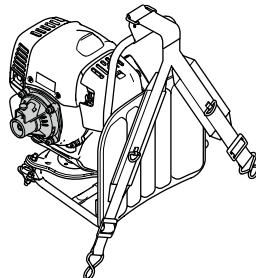

24

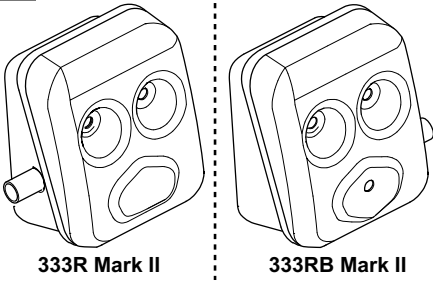

25

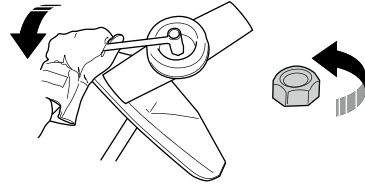

26

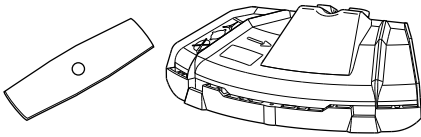

27

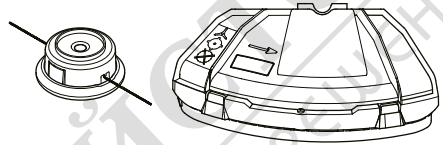

28



29

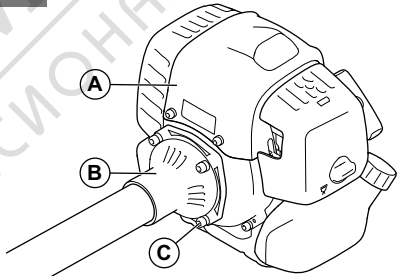

30

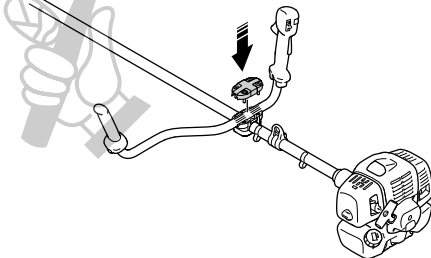

31

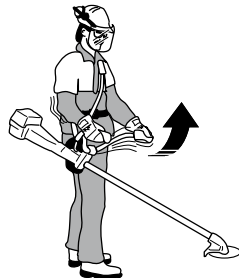

32

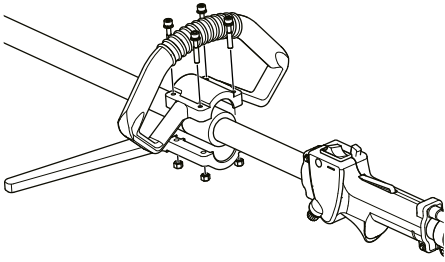

33

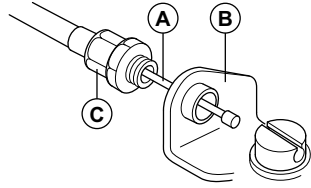

34

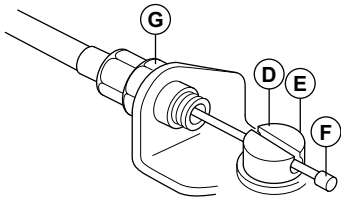

35

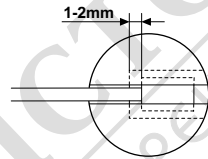

36

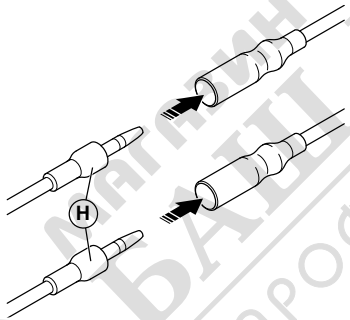

37

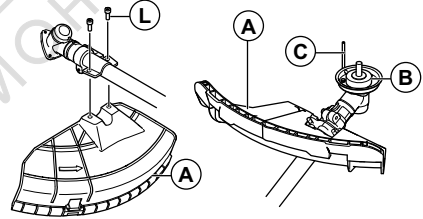

38

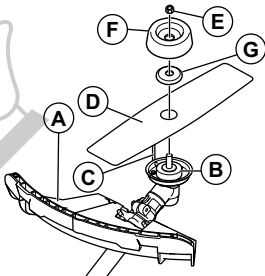

39

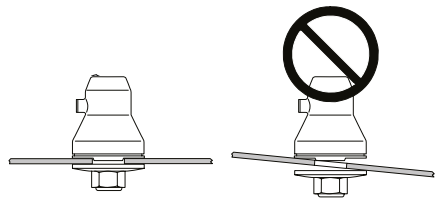

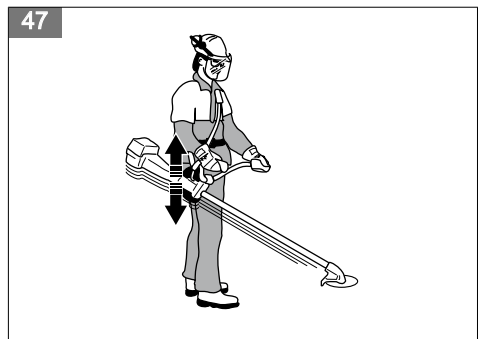
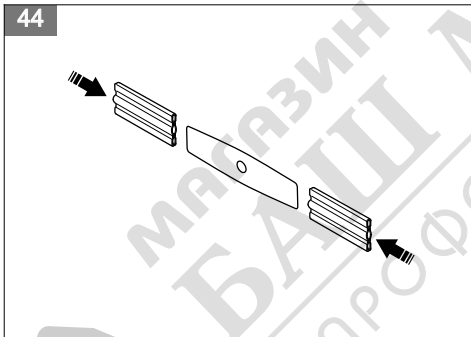
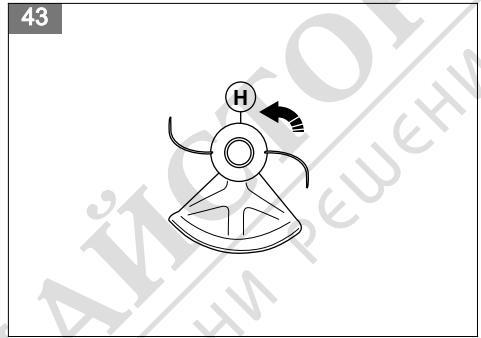
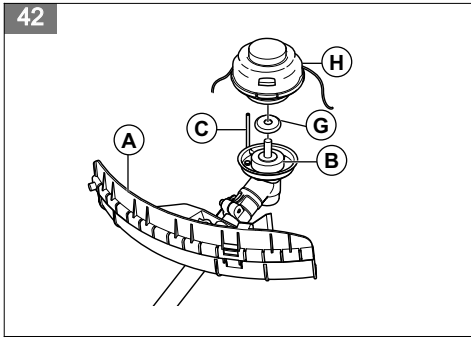
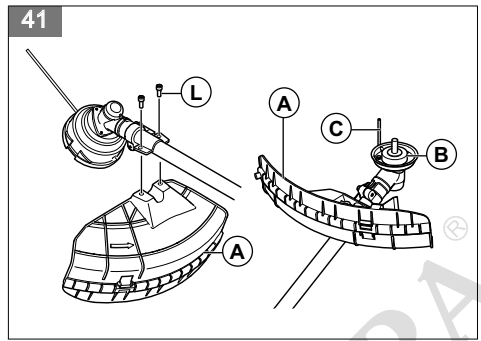
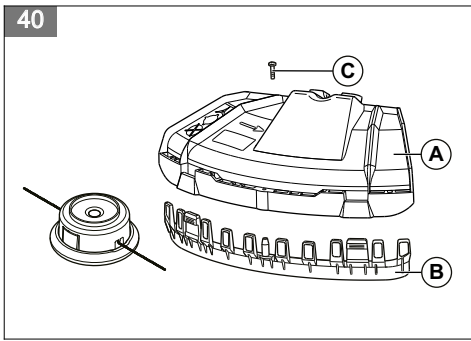

48

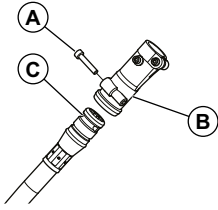

49

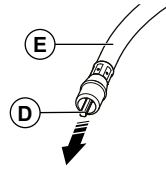

50

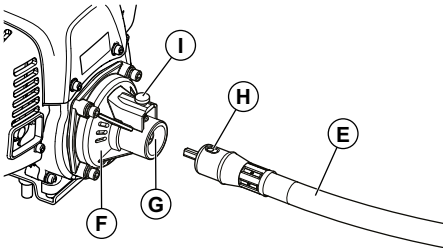

51

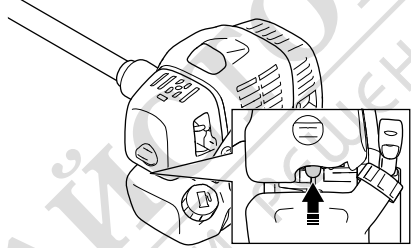

52

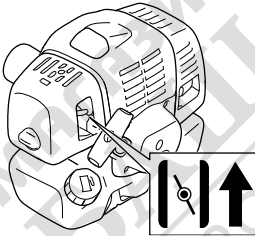

53

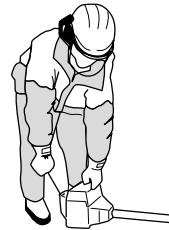

54

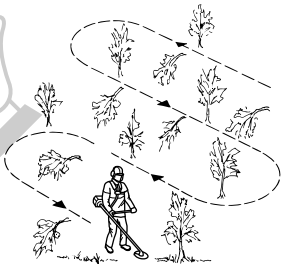

55

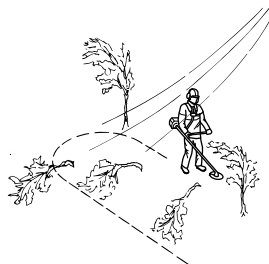

56

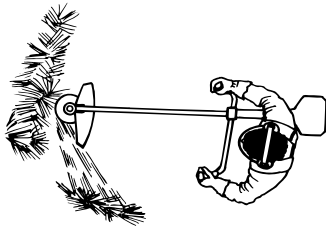

57



58

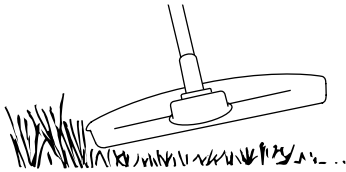

59



60

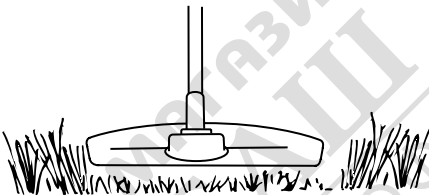

61

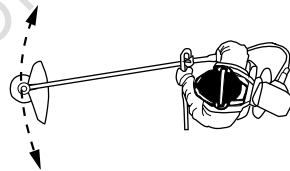

62

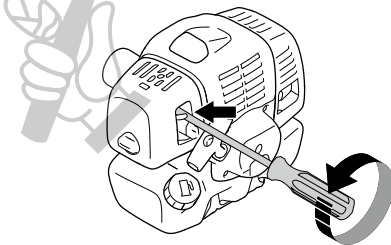

63

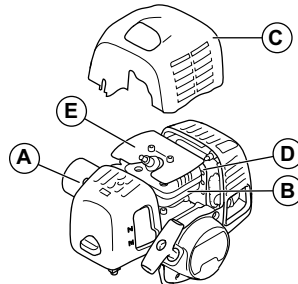

64

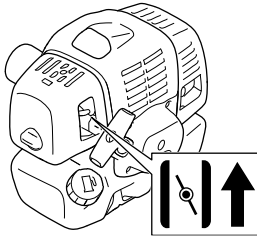

65

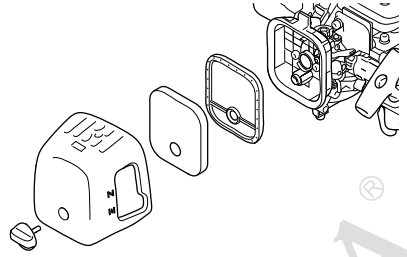

66

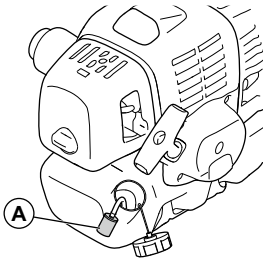

67

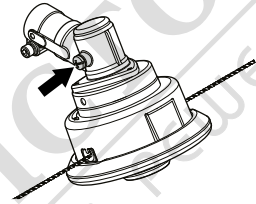

68

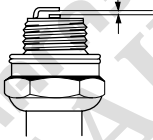

69

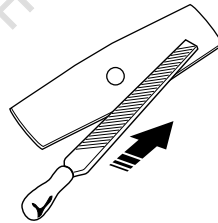

Contents

Introduction.....	10	Transportation and storage.....	23
Safety.....	11	Technical data.....	23
Assembly.....	15	Accessories.....	25
Operation.....	17	EC Declaration of Conformity.....	25
Maintenance.....	20	Appendix.....	77
Troubleshooting.....	22		

Introduction

Product description

This product is a brushcutter with a combustion engine.

Work is constantly in progress to increase your safety and efficiency during operation. Speak to your servicing dealer for more information.

Intended use

The product can be used with a grass blade or a trimmer head to cut different types of vegetation. Do not use

Product overview

(Fig. 1)

1. Grease filler cap, bevel gear
2. Bevel gear
3. Cutting attachment guard
4. Shaft
5. Loop handle
6. Start throttle button
7. Stop switch
8. Throttle trigger
9. Throttle trigger lockout
10. Flexible drive shaft coupling
11. Starter handle
12. Fuel tank
13. Air filter cover
14. Cylinder cover
15. Spark plug cap and spark plug
16. Harness
17. Locking nut
18. Support cup
19. Support flange
20. Drive disc
21. Locking pin
22. Socket spanner
23. Transport guard
24. Operator's manual
25. Spanner
26. Allen key
27. 2-teeth blade
28. Muffler cover

the product for other tasks than grass trimming and grass clearing. Use a grass blade or trimmer head to cut grass.

Note: National or local regulations may regulate the use. Comply to given regulations.

29. Handlebar clamp
30. Handlebar
31. Suspension ring
32. Clutch cover
33. Choke control
34. Air purge

Symbols on the product

(Fig. 2)

WARNING! This product is dangerous. Injury or death can occur to the operator or bystanders if the product is not used carefully and correctly. To prevent injury to the operator or bystanders, read and obey all safety instructions in the operator's manual.

(Fig. 3)

Please read the operator's manual carefully and make sure that you understand the instructions before use.

(Fig. 4)

This product complies with applicable EC Directives.

(Fig. 5)

Use a protective helmet in locations where objects can fall on you. Use approved hearing protection. Use approved eye protection.

(Fig. 6)

Use approved protective gloves.

(Fig. 7)

Use heavy-duty slip-resistant boots.

- (Fig. 8) The product can cause objects to eject, which can cause injury.
- (Fig. 9) Maximum speed of the output shaft.
- (Fig. 10) Keep a minimum of 15 m (50 ft) distance to persons and animals during operation of the product.
- (Fig. 11) Risk of blade thrust if the cutting equipment touches an object that it does not immediately cut. The product can cut off body parts. Keep a minimum of 15 m (50 ft) distance to persons and animals during operation of the product.
- (Fig. 12) Air purge bulb. (333R Mark II)
- (Fig. 13) The direction to close the choke.
- (Fig. 14) The direction to open the choke.
- (Fig. 15) Noise emission to the environment refer to the European Community's Directive.

The emission of the product is specified in *Technical data on page 23* and on the label.

The rating plate shows the serial number. **yyyy** is the production year, **ww** is the production week.

yyyywwxxxx

Note: Other symbols/decals on the product refer to certification requirements for other commercial areas.

Product damage

We are not responsible for damages to our product if:

- the product is incorrectly repaired.
- the product is repaired with parts that are not from the manufacturer or not approved by the manufacturer.
- the product has an accessory that is not from the manufacturer or not approved by the manufacturer.
- the product is not repaired at an approved service center or by an approved authority.

Safety

Safety definitions

The definitions below give the level of severity for each signal word.



WARNING: Injury to persons.



CAUTION: Damage to the product.

Note: This information makes the product easier to use.

General safety instructions



WARNING: Read the warning instructions that follow before you use the product.

- Do not discard this manual. Use the instructions to assemble, to operate and to keep your product in good condition. Use the instructions for correct installation of attachments and accessories. Only use approved attachments and accessories.
- Do not use a damaged product. Obey the maintenance schedule. Only do the maintenance work that you find an instruction about in this manual. An approved service center must do all other maintenance work.
- This manual cannot include all situations that can occur when you use the product. Be careful and use your common sense. Do not operate the product or do maintenance on the product if you are not sure about of the situation. Speak to a product expert, your dealer, service agent or approved service center for information.
- Disconnect the spark plug cable before you assemble the product, put the product into storage or do maintenance.
- Do not use the product if it is changed from its initial specification. Do not change a part of the product without approval from the manufacturer. Only use parts approved by the manufacturer. Injury or death is a possible result of incorrect maintenance.
- Do not breathe in the fumes from the engine. Long-term inhalation of the engine's exhaust fumes is a health risk.
- Do not start the product indoors or near flammable material. The exhaust fumes are hot and can contain a spark which can start a fire. Not sufficient airflow

can cause injury or death because of asphyxiation or carbon monoxide.

- When you use this product the engine makes an electromagnetic field. The electromagnetic field can cause damage to medical implants. Speak to your physician and medical implant manufacturer before you operate the product.
- Do not let a child operate the product. Do not let a person without knowledge of the instructions operate the product.
- Make sure that you always monitor a person, with decreased physical capacity or mental capacity, that uses the product. A responsible adult must be there at all times.
- Lock the product in an area that children and unapproved persons cannot access.
- The product can eject objects and cause injuries. Obey the safety instructions to decrease the risk of injury or death.
- Do not go away from the product when the engine is on.
- The operator of the product is responsible if an accident occurs.
- Make sure that parts are not damaged before you use the product.
- Make sure that you are at minimum 15 m (50 ft) away from other persons or animals before you use the product. Make sure that persons in the adjacent area know that you will use the product.
- Refer to national or local laws. They can prevent or decrease the operation of the product in some conditions.
- Do not use the product if you are fatigued or influenced by alcohol, drugs or medicine. They can have effects on your vision, alertness, coordination or judgment.

Safety instructions for operation

- Make sure the product is fully assembled before you use it.
- Before a start, move the product 3 m (10 ft) away from the position where you filled the fuel tank. Put the product on a flat surface. Make sure that the cutting attachment does not touch the ground or other objects.
- The product can cause objects to eject, which can cause damage to the eyes. Always use an approved eye protection when you operate the product.
- Be careful, a child can come near the product without your knowledge during operation.
- Do not operate the product if there are persons in the work area. Stop the product if a person goes into the work area.
- Make sure that you are always in control of the product.
- Do not use the product if you cannot receive aid if an accident occurs. Always make sure others know you

will operate the product before you start to operate the product.

- Do not turn with the product before you make sure that no persons or animals are in the safety area.
 - Remove all unwanted materials from the work area before you start. If the cutting attachment hits an object, the object can eject and cause injury or damage. Unwanted material can wind around the cutting attachment and cause damage.
 - Do not use the product in bad weather (fog, rain, strong winds, risk of lightning or other weather conditions.). Dangerous conditions (such as slippery surfaces) can occur because of bad weather.
 - Make sure that you can move freely and work in a stable position.
- (Fig. 16)(Fig. 17)
- Make sure that you cannot fall when you use the product. Do not tilt when you operate the product.
 - Always hold the product with your two hands. Hold the product on the right side of your body.
- (Fig. 18)
- Operate the product with the cutting attachment below your waist.
 - If the choke control is in the choke position when the engine starts, the cutting attachment starts to turn.
 - Do not touch the bevel gear after the engine stops. The bevel gear is hot after the engine stops. Hot areas can cause injury.
 - Stop the engine before you move the product.
 - Do not put down the product with the engine on.
 - Before you remove the unwanted materials from the product, stop the engine and wait until the cutting attachment stops. Let the cutting attachment stop before you or an aid remove the cut material.

Personal protective equipment



WARNING: Read the warning instructions that follow before you use the product.

- Always use correct personal protective equipment when you operate the product. The personal protective equipment does not erase the risk of injury. The personal protective equipment decreases the grade of injury if an accident occurs.
- Always use an approved eye protection while you operate the product.
- Do not operate the product with bare feet or with open shoes. Always use heavy-duty slip-resistant boots.
- Use heavy, long pants.
- If it is necessary, use approved protective gloves.
- Use a helmet if it is possible that objects fall on your head.
- Always use approved ear protection while you operate the product. Noise for a long period can cause noise-induced hearing loss.

- Make sure that you have a first aid kit near.

Protective devices on the product

- Make sure that you regularly do the maintenance to the product.
 - The life of the product increases.
 - The risk of accidents decreases.

Let an approved dealer or an approved service center regularly examine the product to do adjustments or repairs.

- Do not use a product with damaged protective equipment. If the product is damaged, speak to an approved service center.

Throttle trigger lockout

The throttle trigger lockout (A) prevents accidental operation of the throttle trigger (B). Push the throttle trigger lockout (A) to release the throttle trigger (B). When you release the handle, the throttle trigger lockout (A) and the throttle trigger (B) go back to their initial positions.

(Fig. 19)

Two isolated return springs control this movement. This means that the throttle trigger (B) is automatically locked at the idle position.

1. Make sure that the throttle trigger (B) is locked at idle when you release the throttle trigger lockout (A).
2. Push the throttle trigger lockout (A) and make sure that it goes back to its initial position when you release it.
3. Push the throttle trigger (B) and make sure that it goes back to its initial position when you release it.

Start the engine, and then apply full throttle. Release the throttle trigger (B) and examine if the cutting attachment stops. If the cutting attachment turns with the throttle in the idle position, examine the idle adjustment screw of the carburetor.

Stop switch

Start the engine. Make sure that the engine stops when you move the stop switch to the stop position.

(Fig. 20)

Cutting attachment guard



WARNING: Do not use a cutting attachment without an approved guard. If an incorrect or damaged guard is installed, this can cause damage to persons.

The cutting attachment guard prevents a loose object to eject in the direction of the operator. Examine the cutting attachment guard for damage and replace if it is damaged. Only use the approved guard for the cutting attachment.

(Fig. 21)

Harness quick release (333R Mark II)



WARNING: Do not use the harness if the harness quick release (A) is damaged. Make sure that the harness quick release operates correctly after you adjust the product and the harness.

The harness quick release (A) is at the front of the product. The harness straps must always stay at the correct position. In an emergency, the harness quick release helps you to safely release from the product.

(Fig. 22)

Vibration damping system (333RB Mark II)



WARNING: Overexposure to vibration can lead to circulatory damage or nerve damage in people who have impaired circulation. Contact your doctor if you experience symptoms of overexposure to vibration. Such symptoms include numbness, loss of feeling, tingling, pricking, pain, loss of strength, changes in skin color or condition. These symptoms normally appear in the fingers, hands, shoulder or wrists. These symptoms may be increased in cold temperatures.

- Your product has a vibration damping system to reduce vibration and make operation easier.
- Incorrect wound trimmer line or blunt or incorrect cutting attachment increases the level of vibration.

(Fig. 23)

Muffler

(Fig. 24)

The muffler keeps the noise level to a minimum and keeps exhaust fumes away from the operator.

- Do not use an engine with a damaged muffler. A damaged muffler increases the noise level and the risk of fire. Keep a fire extinguisher near.
- Examine regularly that the muffler is attached to the product.
- Do not touch the engine or the muffler when then engine is on. Do not touch the engine or the muffler for a while after the engine stops. Hot surfaces can cause injuries.
- A hot muffler can cause a fire. Be careful, if you use the product near flammable liquids or fumes.
- Do not touch the parts in the muffler, if the muffler is damaged. The parts can contain some carcinogenic chemicals.

To attach and remove the locknut



WARNING: Stop the engine, use protective gloves and be careful around the sharp edges of the cutting attachment.

A locknut is used to attach some types of cutting attachments. The locknut has a left thread.

- To attach, tighten the locknut in the opposite direction to the direction of turning of the cutting attachment.
- To remove the locknut, loosen the locknut in the same direction as the cutting attachment rotates.
- To loosen and tighten the locknut, use a socket wrench with a long shaft. The arrow in the picture shows the area where you can operate the socket wrench. (Fig. 25)



WARNING: When you loosen and tighten the locknut, there is a risk of injury from the blade. You must always make sure that the blade guard prevents injury to your hand when you do this.

Note: Make sure that you can not turn the locknut by hand. Replace the nut if the nylon lining does not have a resistance of a minimum of 1.5 Nm. The locknut must be replaced after it has been put on approximately 10 times.

Cutting equipment

Choose and maintain the cutting equipment to:

- Obtain maximum cutting performance.
- Increase life span of the cutting equipment.
- Follow the checking, maintenance and service instructions for the muffler.
- Always use the recommended guard for the cutting equipment. See Technical data.



WARNING: Only use cutting attachments with the guards we recommend! See the chapter on Technical data. Refer to the instructions for the cutting attachment to check the correct way to load the trimmer line and the correct trimmer line diameter.



WARNING: A faulty cutting attachment may increase the risk of accidents.



WARNING: Always stop the engine before doing any work on the cutting attachment. This continues to rotate even after the throttle has been released. Ensure that the cutting attachment has stopped

completely and disconnect the spark plug cap before you start to work on it.

Cutting equipment

- Use the blades and grass knives to cut coarse grass. (Fig. 26)
- Use the trimmer head to trim grass. (Fig. 27)
- An incorrectly sharpened or damaged blade increases the risk of accidents. Keep the teeth of the blade correctly sharpened. Follow the instructions and use the recommended file gauge.
- Check the cutting attachment for damage or cracks. Replace a damaged cutting attachment.
- Only use cutting attachments with recommended guards. Refer to *Accessories on page 25*.

Trimmer head



WARNING: Always make sure the trimmer line is wound tightly and evenly around the drum to prevent harmful vibration.

(Fig. 28)

- Only use recommended trimmer heads and trimmer lines.
- Only use recommended cutting attachments.
- Smaller machines requires small trimmer heads and vice versa.
- The length of the trimmer line is important. A longer trimmer line requires greater engine power than a shorter trimmer line of the same diameter.
- Make sure that the cutter on the trimmer guard is intact. This cuts the trimmer line to the correct length.
- Soak the trimmer line in water for a couple of days before use to increase the life length.

Grass blades and grass cutters

- Use the product with an approved grass blade. Do not use a grass blade without proper installation of all required parts. Make sure that the installation is done correctly and that the proper parts are used. Improper installation may cause the blade to fly off and seriously injure the operator or the bystanders.
- Wear protective gloves when you handle or do maintenance on the blade.
- Use head protection when you operate a product with a grass blade.
- Grass blades and grass cutters are used to cut rough grass.
- A grass blade can cause injury while it continues to spin after the engine is stopped or the throttle trigger is released. Make sure that the grass blade has completely stopped rotating before any maintenance.

- Stop the engine before you do work on the cutting attachment. Make sure the cutting attachment fully stops. Disconnect the lead from the spark plug.
- Only use an approved cutting attachment or a correctly sharpened blade.
- Keep the teeth of the blade correctly sharpened.
- Do not use a damaged cutting attachment.
- Attach the transport guard to the grass blade when you transport or store the product.
- Be careful with fuel. Fuel is flammable and the fumes are explosive and can cause injuries or death.
- Do not breathe in the fuel fumes, it can cause injury. Make sure that there is a sufficient airflow.
- Do not smoke near the fuel or the engine.
- Do not put warm objects near the fuel or the engine.
- Do not add the fuel when the engine is on.
- Make sure that the engine is cool before you refuel.
- Before you refuel, open the fuel tank cap slowly and release the pressure carefully.

Blade thrust

- A blade thrust is a sudden movement of the product to the side, forward or rearward. A blade thrust occurs when the grass blade hits an object that cannot be cut. In areas where it is not easy to see the material being cut the risk of blade thrust increases.
- When a blade thrust occurs, there is a risk that the product or the operator moves out of position. A blade that moves can hit bystanders and there is a risk of injuries.
- If a blade is bent, has cracks, is broken or damaged, discard the blade.
- Use a sharp blade. The risk of blade thrust increases when a blade is not sharp.

Fuel safety

- Do not start the product if there is fuel or engine oil on the product. Remove the unwanted fuel/oil and let the product dry. Remove unwanted fuel from the product.
- If you spill fuel on your clothing, change clothing immediately.
- Do not get fuel on your body, it can cause injury. If you get fuel on your body, use a soap and water to remove the fuel.
- Do not start the engine if you spill oil or fuel on the product or on your body.
- Do not start the product if the engine has a leak. Examine the engine for leaks regularly.
- Tighten the fuel tank cap carefully or a fire can occur.
- Move the product at a minimum of 3 m (10 ft) from the position where you filled the tank before a start.
- Do not put too much fuel in the fuel tank.
- Make sure that a leak cannot occur when you move the product or fuel container.
- Do not put the product or a fuel container where there is an open flame, spark or pilot light. Make sure that the storage area does not contain an open flame.
- Only use approved containers when you move the fuel or put the fuel into storage.
- Empty the fuel tank before long-term storage. Obey the local law on where to dispose fuel.
- Clean the product before long-term storage.
- Remove the spark plug cable before you put the product into storage to make sure that the engine does not start accidentally.

Safety instructions for maintenance

- If you cannot adjust the idle speed to make the cutting attachment stop, speak to your service center. Do not use the product until the product is correctly adjusted or repaired.

Assembly



WARNING: Read the safety chapter before you assemble the product.

To install the main body (333R Mark II)

1. Connect the engine (A) to the tube (B) with four screws (C). (Fig. 29)

To install the handlebar and throttle (333R Mark II)

1. Install the handlebar in the handlebar clamp on the shaft. (Fig. 30)

2. Install the top part of the handlebar clamp onto the handlebar. Make sure that the clamp is installed onto the knurling area of the handlebar. Refer to the illustration.
3. Put on the harness and hang the product from the support hook.
4. Make a last adjustment to make sure the product is in a comfortable position when it hangs from the harness. (Fig. 31)
5. Tighten the screws.

To install the loop handle (333RB Mark II)

1. Remove the four screws.

- Put the loop handle on the shaft and put the lower clamp below the shaft.
- Align the lower clamp pin with the correct hole in the shaft and put the pin in the hole.
- Align the hole in the loop handle with the screw hole in the lower clamp.
- Install the screws with nuts and tighten. (Fig. 32)

To connect the throttle cable and stop switch wires

- Remove the air filter cover.
- Install the throttle cable (A) through the carburettor bracket (B). (Fig. 33)
- Turn the cable adjuster sleeve (C) into the carburettor bracket fully.
- Put the slot fitting (D) on the carburettor. At this time, the recessed hole (E) for the cable lug (F) is away from the cable adjuster sleeve (C). (Fig. 34)
- Rotate the carburettor throttle cam and move the throttle cable (A) through the slot in the slot fitting.
- Make sure the cable lug (F) drops into the recessed hole.
- Operate the throttle trigger some times to make sure that it operates correctly.
- Adjust the cable adjuster sleeve (C).
 - Make sure the stop on the carburettor throttle cam touches the throttle stop correctly.
 - Make sure the cable position keeps 1-2 mm between cable lug (F) and slot fitting when the throttle trigger is fully pushed. (Fig. 35)
- When the throttle cable (A) is adjusted correctly, tighten the locknut (G).
- Connect the stop switch wires (H) with the connectors from the engine. (Fig. 36)
- Install the air filter cover.

To install a blade guard and grass blade



CAUTION: Only use the approved guard for the blades. See *Accessories* on page 25.

- Attach the blade guard/cutting attachment guard (A) onto the shaft and tighten with the bolt (L). (Fig. 37)
- Install the drive disc (B) on the output shaft.
- Turn the output shaft until one of the holes in the drive disc aligns with the related hole in the gear housing.
- Put the locking pin (C) in the hole to lock the shaft.
- Put the blade (D), support flange (G) and support cup (F) on the output shaft.

- Put the support cup (F) on the output shaft with the not flat side against the blade.
- Install the nut (E). Hold the shaft of the wrench near the blade guard as much as possible. To tighten the nut, you must turn the wrench in the opposite direction of rotation. Tighten the nut to a torque of 35-50 Nm (3.5-5 kpm). (Fig. 38)

Note: Left hand thread. 

To install blades and trimmer heads



WARNING: Only use the approved guard for the blades. See *page 25*. A damaged guard can cause injury.



WARNING: If you operate the product with a grass blade, first install the correct handlebar, blade guard and harness .



WARNING: If you do not install the blades correctly, it can cause injury.

- Make sure that the lifted section on the drive disc/ support flange engages correctly in the center hole of the blades.
- Install the blades. (Fig. 39)

To install the bracket on the cutting attachment guard

- install the bracket (B) on the cutting attachment guard (A). (Fig. 40)
- Install the screw (C).

To attach the trimmer guard and the trimmer head

- Attach the guard (A) to the shaft with the bolts (L). Make sure to use the correct guard for the correct trimmer head. (Fig. 41)
- Attach the drive disc (B) and support flange (G) to the output shaft. (Fig. 42)
- Turn the output shaft until the hole in the drive disc aligns with the hole in the gear housing.
- Put the locking pin (C) in the hole to lock the shaft.
- Turn the trimmer head (H) counterclockwise. (Fig. 43)
- To disassemble, do the reverse procedure.

To install the transport guard

- Attach the transport guards on the blade. (Fig. 44)

To adjust the harness



WARNING: The product must always be correctly attached to the harness. If not, you cannot control the product safely and this can result in injury to you or others. Do not use a damaged harness. Do not use a harness with a quick release that does not operate correctly.

1. Put on the harness.
2. Connect the product to the harness.
3. Adjust the harness for the best work position.
4. Adjust the side straps to make the product weigh equally on your shoulders.
 - a) (333R Mark II) (Fig. 45)
 - b) (333RB Mark II) (Fig. 46)
5. Adjust the harness until the cutting attachment is parallel to the ground. (Fig. 47)
6. Let the cutting attachment stay lightly on the ground. Adjust the harness clamp to balance the product correctly.

Note: If you use a grass blade, it must balance approximately 10 cm /4 in above the ground.

To install the liner (333RB Mark II)

1. Remove the bolt (A) on the joint (B) of the outer pipe. (Fig. 48)

2. Align the groove (C) of the liner with the thread hole and tighten the screw.
3. Turn the flexible shaft (D) at the opposite end from the liner (E) to install it into the joint (B) tightly. (Fig. 49)

IMPORTANT: After you connect the inner shaft to the shaft of the outer pipe, pull on the flexible shaft by hand to make sure the flexible shaft does not come off.

4. Put the liner (E) straight and align the flexible shaft (D) with the angular hole (G) on the side of the clutch drum. (Fig. 50)
5. Install the liner (E) into the clutch housing (F). Make sure that the hole on the end of the liner points directly up.
6. When the hole (H) moves directly below the stopper (I), you can hear a click which means the stopper locks the liner.
 1. If you cannot lock the liner (E) into position, pull it out.
 2. Turn the flexible shaft a small distance and try to lock the liner (E) again.
7. After you lock the liner (E) into position, pull on the liner to make sure the stopper works correctly.

Operation



WARNING: Read and understand the safety chapter before you operate the product.



CAUTION: Do not use gasoline with more than 10% ethanol concentration (E10). This can cause damage to the product.

Fuel

To use fuel



CAUTION: This product has a two-cycle engine. Use a mixture of gasoline and two-cycle engine oil. Make sure to use the correct quantity of oil in the mixture. Incorrect ratio of gasoline and oil can cause damage to the engine.



CAUTION: Do not use leaded gasoline. This can cause damage to the product.

Gasoline



CAUTION: Do not use gasoline with an octane number less than 90 RON (87 AKI). This can cause damage to the product.

- Always use new unleaded gasoline with a minimum octane number of 90 RON (87 AKI) and with less than 10% ethanol concentration (E10).
- Use gasoline with a higher octane number if you frequently use the product at continuously high engine speed.
- Always use a good quality unleaded gasoline/oil mixture.

Two-cycle engine oil

- Use only the two-cycle engine oil of high quality, especially HUSQVARNA two-cycle oil. Use only the oil of an air cooled engine.
- Mixture ratio 50:1 (2%).

- Oil of low quality and high oil/fuel ratio can decrease the lifetime of catalytic converters.
- Speak to your dealer when you select an oil.
- If Husqvarna two-stroke oil is not available, you can use another two-stroke oil of good quality that is intended for air cooled engines. Contact your dealer when you select oil.
- Do not use the two-stroke oil for water-cooled outboard engines. The two-stroke oil is sometimes referred to as outboard oil.

Gasoline, liter	Oil, liter
	2%(50:1)
5	0,1
10	0,2
15	0,3
20	0,4

To make the fuel mixture

Note: Always use a clean fuel container when you mix the fuel.

Note: Do not make more than 30 days quantity of fuel mixture.

1. Add half of the gasoline quantity.
2. Add the full quantity of oil.
3. Shake the fuel mixture to mix the contents.
4. Add the remaining gasoline quantity.
5. Shake the fuel mixture to mix the contents.
6. Fill the fuel tank.

To add fuel



WARNING: Do not smoke or put hot objects near fuel. Before you add fuel, stop the engine and let it cool for minutes.



WARNING: When you add fuel, open the fuel tank cap slowly to release unwanted pressure.



WARNING: After you add fuel, tighten the fuel tank cap carefully. Move the machine away from the refuelling area and the power before you start the engine.

- Always use a fuel container with an anti-spill valve.

- Make sure that the area near the fuel tank cap is clean. Contamination in the tank can cause operating problems.
- Shake the fuel container before you add the fuel mixture to the fuel tank.

To start and stop

To examine before start

1. Examine the product for missing, damaged, loose or worn parts.
2. Examine the nuts, screws and bolts.
3. Examine the blades.
4. Examine the locknut. Make sure that the locknut has a minimum locking force of 1.5 Nm (1,1 ft lb). Torque the locknut to 35-50 Nm (26-36 ft lb).
5. Examine the air filter.
6. Examine the throttle trigger lockout and the throttle control.
7. Examine the stop switch.
8. Examine the product for fuel leaks.

To start a cold engine



WARNING: Before you start the product, install the complete clutch cover and shaft. The loose clutch can cause injury. Use gloves.



WARNING: Move the product away from the refuelling area and the power. Put it on a flat surface. Make sure that no objects touch the cutting attachment.



WARNING: Make sure that no unauthorised persons are in the work area. Or it can cause a risk of dangerous injury. The safety distance is 15 m.

1. Put the stop switch to the start position.
2. Press the air purge ten times. (Fig. 51)
3. Move choke control to the choke position. (Fig. 52)
4. Hold the product to the ground. Pull out the cord slowly with your right hand until you feel some resistance. Pull the cord quickly and with force. Keep doing it until you hear the engine start. (Fig. 53)

Note: Do not twist the starter rope around your hand.



CAUTION: Do not pull all the starter rope out. Hold the starter rope handle when it is fully extended. Failure to obey

these instructions can cause damage to the engine.

5. Set the choke control to the run position, then pull the start rope until the engine starts.
6. Pull the throttle trigger lightly and run at low speed for 60 seconds.



WARNING: Do not touch the cover. It can burn your skin and cause electrical shock if the spark plug cap is damaged. Do not use a product with damaged spark plug cap.

To start a warm engine

1. Put the stop switch to the start position.
2. Press the air purge ten times. (Fig. 51)
3. Set the choke control to the run position, then pull the start rope until the engine starts.

To stop

- Push the stop switch to stop the engine. (Fig. 20)

To operate the grass trimmer



CAUTION: Make sure that you slow the engine to idle speed after each operation. A long period at full throttle without a load on the engine can cause damage to the engine.

Note: Clean the cover of the trimmer head when you attach a new trimmer line to prevent vibrations. Examine other parts of the trimmer head and clean if it is necessary.

General work instructions



WARNING: Be careful when you cut a tree that is in tension. It can spring back to its normal position before or after the cut and hit you or the product, and cause injury.

- Clear an open space at one end of the work area, and start the work from there.
- Move in a regular pattern across the work area. (Fig. 54)
- Move the product fully to the left and right, to clear a width of 4-5 m (13-16 ft) on each turn.
- Clear a length of 75 m (250 ft) before you turn and go back. Move the fuel can along with you as you continue.
- Move in a direction where you do not go across ditches and obstacles more than necessary.
- Move in a direction where the wind makes the cut vegetation fall in the cleared area. (Fig. 55)
- Move along slopes, not up and down.

To clear grass with a grass blade

1. Keep your feet apart during operation of the product. Make sure feet are tightly against the ground.
2. Put the support cup lightly on the ground. This prevents the blade from touching the ground.
3. Use a sideways movement from right to left for a clear stroke. Use the left side of the blade (between 8 and 12 o'clock) to cut. (Fig. 56)
4. Angle the blade to the left when you clear grass.

Note: The grass collects easily in a line.

5. Use a sideways movement from left to right for the return stroke.
6. Do the work rhythmically.
7. Move forward and keep feet tightly against the ground.
8. Stop the engine.
9. Remove the product from the clip on the harness.
10. Put the product on the ground.
11. Collect the cut material.

To clear

(Fig. 57)

To achieve the best results:

- Hold the trimmer so that the trimmer head is just above the ground.
- Tilt the trimmer head at a slight angle.
- Let the end of the trimmer line strike the ground around objects.

To trim the grass

1. Hold the trimmer head immediately above the ground at an angle. Do not push the trimmer line into the grass. (Fig. 58)
2. Decrease the length of the trimmer line by 10-12 cm / 4-4.75 in.
3. Decrease the engine speed to decrease the risk of damage to plants.
4. Use 80 % throttle when you cut grass near objects. (Fig. 59)

To cut the grass

1. Make sure that the grass trimmer line is parallel to the ground when you cut. (Fig. 60)
2. Do not push the trimmer head to the ground. The ground and the product can be damaged.
3. Do not let the trimmer head touch the ground continuously, it can cause damage to the trimmer head.
4. Use full throttle when you move the product from side to side to cut grass. Make sure that the grass trimmer line is parallel to the ground. (Fig. 61)

To sweep the grass

The airflow from the rotating trimmer line can be used to remove cut grass from an area.

1. Hold the trimmer head and its trimmer line parallel to the ground and above the ground.
2. Apply full throttle.
3. Move the trimmer head from side to side and sweep the grass.

line to prevent unbalance and vibrations in the handles. Also do a check of the other parts of the trimmer head and clean it if necessary.



WARNING: Clean the trimmer head cover each time you assemble new trimmer

To replace trimmer line

Refer to the last page of this operator's manual.

Maintenance



WARNING: Read and understand the safety chapter before you clean, repair or do maintenance on the product.

product. The intervals are different if you do not use the product each day. Only do the maintenance work that is found in this manual. Speak to an approved service center about other maintenance work not found in this manual.

Maintenance schedule

Make sure that you obey the maintenance schedule. The intervals are calculated from daily use of the

Maintenance schedule	Daily	Weekly	Monthly
Clean the external surfaces.	✓		
Clean the air filter. Replace if necessary.	✓		
Do a check of the harness.	✓		
Do a check of the throttle trigger lock and the throttle function.	✓		
Do a check of the handle and the handlebar.	✓		
Do a check of the stop switch.	✓		
Do a check of the guards.	✓		
Do a check of the blade that it is sharp and not damaged. Install the blade to the center position correctly.	✓		
Do a check of the trimmer head.	✓		
Do a check of the cutting attachment and make sure that it does not rotate at idle.	✓		
Do a check of the locknut of the cutting equipment.	✓		
Do a check of fuel leaks from the engine, tank or fuel lines.	✓		
Do a check of the transport guard for the blade.	✓		
Do a check of the nuts and screws.	✓		
Do a check of the starter rope handle and the starter rope.		✓	
Do a check of the vibration damping elements.		✓	
Clean the external part and the adjacent areas of the carburettor.		✓	

Maintenance schedule	Daily	Weekly	Monthly
Clean the external part of the spark plug. Remove it and check the electrode gap. Adjust the distance to 0.6-0.7 mm or replace the spark plug. Install a suppressor to the spark plug.		√	
Clean the cooling system.		√	
Do a check of the bevel gear lubricant. Fill if necessary.		√	
Clean the muffler.			√
Do a check of the clutch, clutch springs and the clutch drum. Replace if necessary by an approved service center.			√
Do a check of all cables and connections.			√
Replace the spark plug.			√

To adjust the carburetor

The basic carburetor settings are adjusted during testing at the factory. Adjustment must be carried out by a trained technician.

To do a check of the muffler



WARNING: Do not use a product that has a damaged muffler. Always replace a damaged muffler.



WARNING: Risk of burn injury or fire. Mufflers with catalytic converters become very hot during operation.



WARNING: Risk of fire. The muffler decreases the noise level and points the exhaust gases away from the operator. The exhaust gases are hot and can contain sparks.



CAUTION: The spark arrester screen must be replaced if it is damaged. Do not use a product if the spark arrester screen on the muffler is missing or damaged.



CAUTION: If the spark arrester screen is blocked, the product becomes very hot and this causes damage to the cylinder and piston.

1. Make sure that the muffler is not damaged.
2. Make sure that the muffler is correctly attached to the product.

To adjust the idle speed

- Make sure that the air filter is clean. The cutting attachment must not rotate in correct idle speed.

- Adjust the idle speed with the idle adjustment screw T which is identified with "T" mark.
- The idle speed is correct when the engine operates smoothly in all positions. The idle speed must be below the speed when the cutting attachment starts to turn.



WARNING: If the idle speed cannot be adjusted so that the cutting attachment stops, speak to the distributor or the service center. Do not use the product until it is correctly adjusted or repaired.

1. Turn the idle adjustment screw clockwise until the cutting attachment starts to turn.
2. Turn the idle adjustment screw counterclockwise until the cutting attachment stops. (Fig. 62)

Cooling system

The product has a cooling system to keep the work temperature low.

The cooling system has:

(Fig. 63)

- Fins on the flywheel (A)
- Cooling fins on the cylinder (B)
- Cylinder cover (C) (directs cold air over the cylinder)
- Muffler plate (D)
- Plate (E)

To clean the cooling system



WARNING: A dirty or blocked cooling system causes overheating. It causes damage to the piston and cylinder.

1. Clean the parts of the cooling system with a brush a minimum of one time a week.

Air filter

- Clean the filter at intervals of 25 hours. Clean more regularly if necessary.
- Set the choke control in the choke position. (Fig. 64)

To clean the air filter



CAUTION: Always replace an air filter that is damaged, very dirty or soaked with fuel.

If you use an air filter for a long time, it cannot be fully cleaned. Replace the air filter with a new one at regular intervals.

1. Move the choke lever up, to close the choke valve.
2. Remove the air filter cover. (Fig. 65)
3. Remove the felt filter and the air filter.
4. Hit the palm of your hand lightly with the felt filter or use air to clean the felt filter.
5. Do a check of the surface of the rubber seal. Replace the filter on the rubber seal if it is damaged.
6. Clean the air filter with warm soap water.



CAUTION: Make sure to keep the felt filter dry. Water causes damage to the felt filter.

7. Use Husqvarna two-stroke oil to put oil on the filter. Make sure that you remove excessive oil before you put the air filter back.



CAUTION: Do not use gasoline or oil intended for four-stroke engines.

8. Replace the air filter if it is too dirty to fully clean it. Always replace a damaged air filter.
9. Also clean the inner surface of the filter cover. Use air or a brush.
10. Make sure that the filter is dry before you assemble it.

Fuel filter

When the engine runs short of fuel supply, make sure that the fuel tank cap and the fuel filter (A) is not blocked.
(Fig. 66)

To add grease to the bevel gear

Make sure that the bevel gear is filled 3/4 full with bevel gear grease.

(Fig. 67)

To do a check of the spark plug



CAUTION: Always use the recommended spark plug type. Incorrect spark plug type can cause damage to the product.

- Do a check of the spark plug if the engine is low on power, is not easy to start or does not operate correctly at idle speed.
- To decrease the risk of unwanted material on the spark plug electrodes, obey these instructions:
 - a) Make sure that the idle speed is correctly adjusted.
 - b) Make sure that the fuel mixture is correct.
 - c) Make sure that the air filter is clean.
- If the spark plug is dirty, clean it and make sure that the electrode gap is correct, refer to *Technical data on page 23*. (Fig. 68)
- Replace the spark plug if it is necessary.

To sharpen grass cutters and grass blades

1. Sharpen grass cutters and grass blades with a single-cut flat file.
2. Sharpen all edges of the grass cutters and blades equally to keep the balance. (Fig. 69)

Troubleshooting

Starting failure		
Check	Possible cause	Solution
Stop button	Stop position	Set the stop switch to the start position.

Starting failure		
Check	Possible cause	Solution
Starter pawls	Binding pawls	Adjust or replace the pawls.
		Clean around the pawls.
		Speak to an approved servicing dealer.
Fuel tank	Incorrect fuel type.	Drain it and use correct fuel.
Carburettor	Adjustment of the idle speed.	Adjust the idle speed with the T-screw.
Spark (no spark)	Spark plug dirty or wet.	Make sure that the spark plug is dry and clean.
	Spark plug clearance incorrect.	Clean the spark plug. Check that the electrode gap is correct. Make sure that the spark plug is installed with a suppressor.
		Refer to technical data for correct electrode gap.
Spark plug	Spark plug loose.	Tighten the spark plug.

Engine starts but does not stay running		
Check	Possible cause	Solution
Fuel tank	Incorrect fuel type.	Drain it and use correct fuel.
Carburettor	Engine will not idle correctly.	Speak to your servicing dealer.
Air filter	Clogged air filter.	Clean the air filter.

Transportation and storage

- Keep equipment safe during transportation to prevent damage and accidents.
- Keep the product and equipment in a dry and frost-proof area.
- Clean the product.
- Replace or repair damaged components.
- Use the correct protective cover on the product that does not keep moisture.
- Keep the product tightly attached during transport.

Technical data

	unit	333R Mark II	333RB Mark II
Engine specifications			
Cylinder displacement	cm ³	32.6	32.6

Cylinder bore	mm	36.0	36.0
Stroke	mm	32.0	32.0
Idling speed	rpm	3000±300	3000±300
Maximum speed	rpm	10600	10600
Speed of output shaft	rpm	7800	7800
Maximum engine output	kW/rpm	1.0/7000	1.0/7000
Spark plug		NGK BPMR7A	NGK BPMR7A
Electrode gap	mm	0.6-0.7	0.6-0.7
Fuel tank capacity	cm ³	1100	1100
Vibration data			
Equivalent vibration level (ahv, eq), equipped with grass blade, front/back handle - see note 1	m/s ²	-	4.6/5.0
Equivalent vibration level (ahv, eq) equipped with trimmer head, front/back handle - see note 1	m/s ²	-	4.8/3.6
Equivalent vibration level (ahv, eq), equipped with grass blade, left/right handle - see note 1	m/s ²	5.4/5.5	-
Equivalent vibration level (ahv, eq) equipped with trimmer head, left/right handle - see note 1	m/s ²	6.1/6.2	-
Noise data			
Guaranteed sound power level according to 2000/14/EC	dB(A)	108	108
Measured sound power level according to 2000/14/EC	dB(A)	107	101
Sound pressure level at operator's ear, equipped with grass blade - see note 2	dB(A)	97	101
Sound pressure level at operator's ear, equipped with trimmer head - see note 2	dB(A)	97	98
Sound power level, measured, equipped with grass blade - see note 3	dB(A)	104	108
Sound power level, measured, equipped with trimmer head -see note 3	dB(A)	104	108
Weight			
Weight	kg	7.2	9.5
<p>Note 1: Equivalent total vibration value for each handle, determined in accordance with EN ISO 22867. The uncertainty of stated values is 1.5 m/s².</p> <p>Note 2: Equivalent emission sound pressure level at the operator position, determined in accordance with EN ISO 22868. The uncertainty of stated values is 3 dB(A).</p> <p>Note 3: Sound power level measured according to EN ISO 22868. The uncertainty of stated values is 3 dB(A).</p>			

Accessories

333R Mark II, 333RB Mark II		
Approved accessories	Type	Cutting attachment guard
Grass blade/ grass cutter	Multi 255-3 (Ø 255 3 teeth)	593 70 66-01
	Grass 275-4 (Ø 275 4 teeth)	593 70 66-01
	Grass 255-4 1" (Ø 255 4 teeth)	593 70 66-01
Trimmer head	593707601	593 70 66-01
Support cup	Fixed	-

EC Declaration of Conformity

Issuer's name: Husqvarna AB, SE-561 82 Huskvarna, Sweden, tel: +46-36-146500.

Husqvarna AB claims sole responsibility for the object of this declaration: Trimmer and/or Brushcutter powered by petrol, platform(s) GZ32B representing model(s) **Husqvarna 333R Mark II, 333RB Mark II**, from 2024 serial numbers and onwards. The platform number and model number are clearly stated in plain text on the type plate along with the year with subsequent serial numbers.

The object of the declaration described above is in conformity with the requirements of the Council's Directives:

- of May 17, 2006 "relating to machinery" **2006/42/EC**.
- of February 26, 2014 "relating to electromagnetic compatibility" **2014/30/EU**.
- of May 8, 2000 "relating to the noise emissions in the environment" **2000/14/EC**.
- of June 8, 2011 on the "restriction of use of certain hazardous substances" **2011/65/EU**.

Applied conformity assessment procedure in accordance with Directive 2000/14/EC, Annex V.

For information relating to noise emissions, refer to *Technical data on page 23*.

The following standards have been applied:

EN ISO 11806-1:2022, EN ISO 11806-2:2022, EN ISO 14982:2009, EN ISO 12100:2010, EN IEC 63000:2018

TÜV Rheinland LGA Products GmbH, Tillystrasse 2, D-90431 Nuernberg, Germany, 0197, has carried out a voluntary examination on behalf of Husqvarna AB, providing AM 50613402 for 333R Mark II - Certificate of Conformity to EC Council directive 2006/42/EC for machinery. TÜV SÜD Product Service GmbH,

Certification Body, Ridlerstraße 65, 80339 Munich, Germany, has carried out a voluntary examination on behalf of Husqvarna AB, providing M8A 024735 0079 Rev.01 for 333RB Mark II - Certificate of Conformity to EC Council directive 2006/42/EC for machinery. These certificates are applicable to all manufacturing locations and Countries of Origin, as stated on the product. The supplied grass trimmer and/or brushcutter conforms to the example that underwent examination.

Husqvarna AB, Huskvarna, Sweden, 2024-01-15



Claes Losdal, R&D Manager, Husqvarna AB
Responsible for technical documentation

