

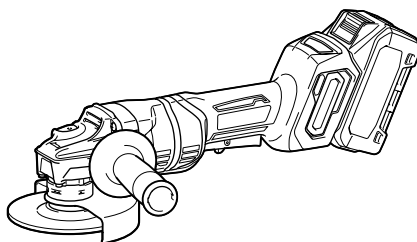

EN	Cordless Angle Grinder	INSTRUCTION MANUAL	8
FR	Meuleuse d'Angle sans Fil	MANUEL D'INSTRUCTIONS	22
DE	Akku-Winkelschleifer	BETRIEBSANLEITUNG	37
IT	Smerigliatrice angolare a batteria	ISTRUZIONI PER L'USO	53
NL	Haakse accuslijpmachine	GEBRUIKSAANWIJZING	69
ES	Esmeriladora Angular Inalámbrica	MANUAL DE INSTRUCCIONES	84
PT	Esmerilhadeira Angular a Bateria	MANUAL DE INSTRUÇÕES	100
DA	Ledningsfri vinkelsliber	BRUGSANVISNING	115
EL	Φορητός γωνιακός λειαντήρας	ΕΓΧΕΙΡΙΔΙΟ ΟΔΗΓΙΩΝ	129
TR	Akülü Avuç Taşlama Makinesi	KULLANMA KILAVUZU	145

GA048G
GA049G
GA050G
GA051G

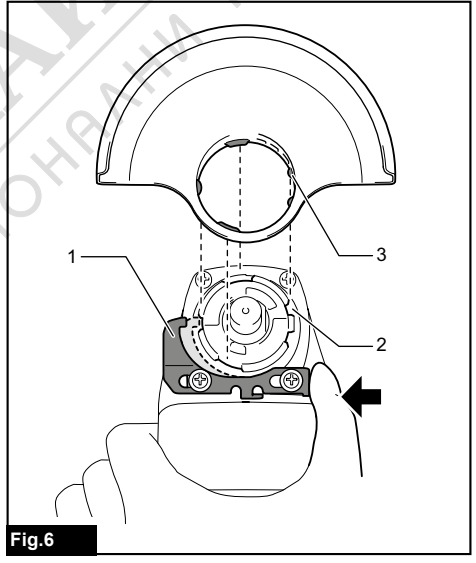

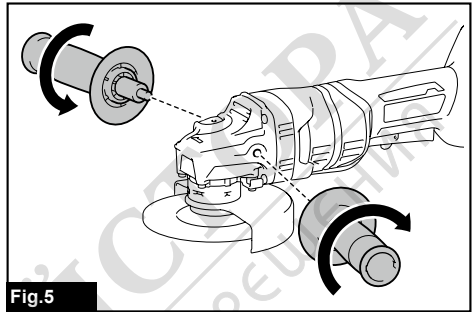
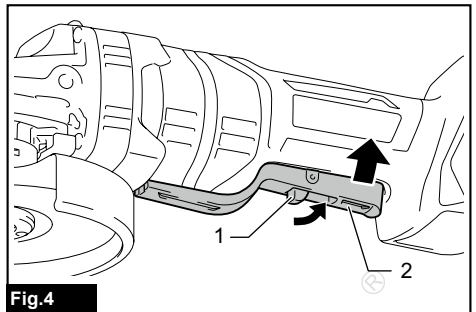
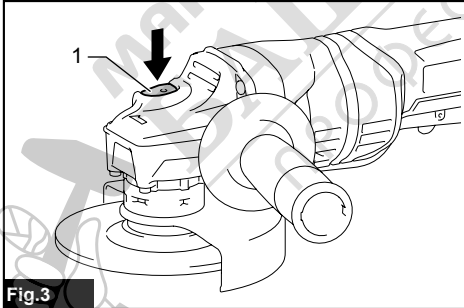
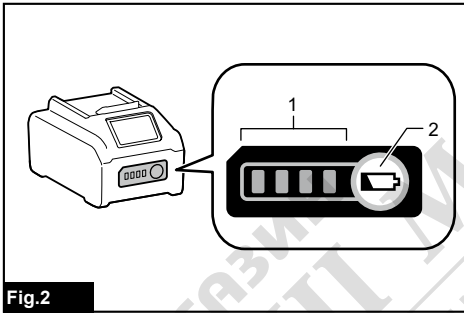
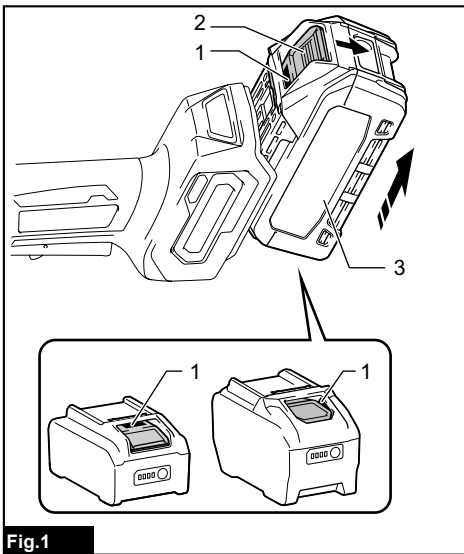

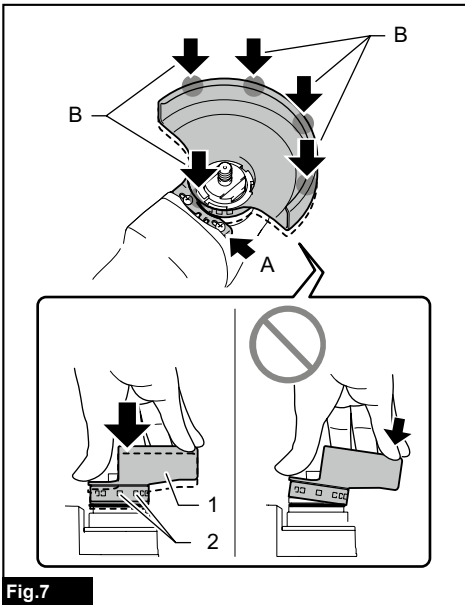

Fig.7

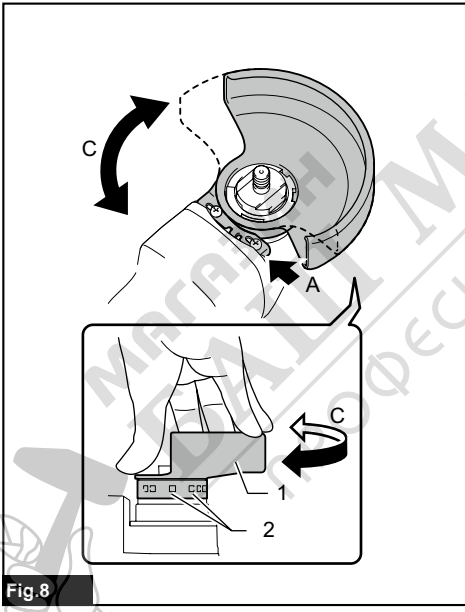

Fig.8

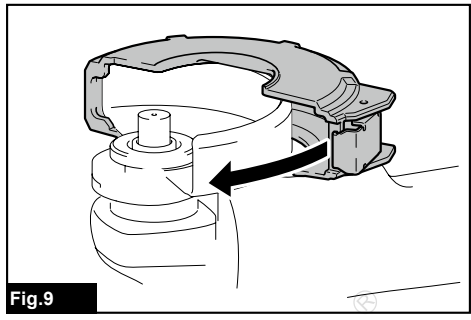

Fig.9

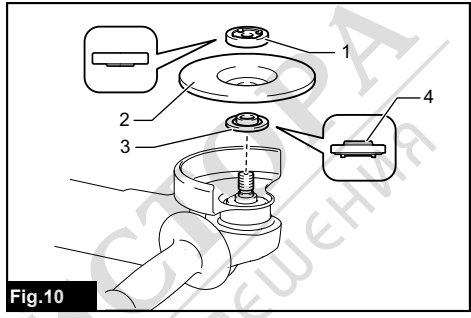

Fig.10

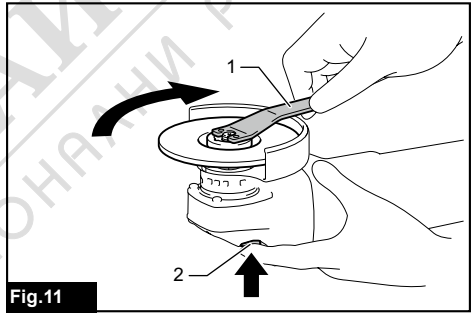

Fig.11

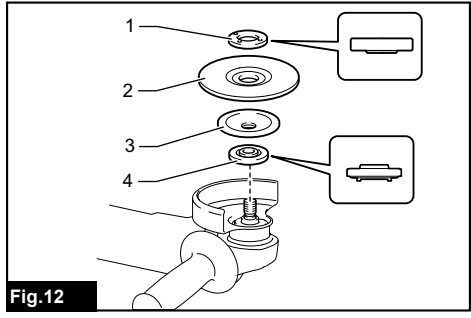

Fig.12

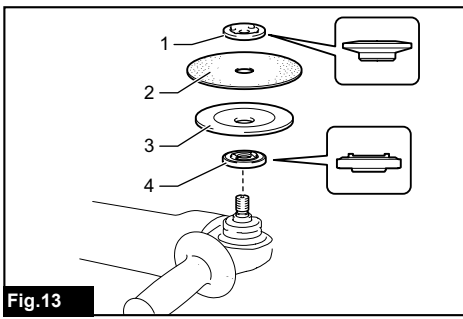

Fig. 13

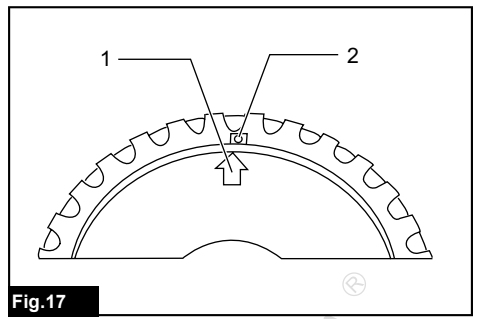

Fig. 17

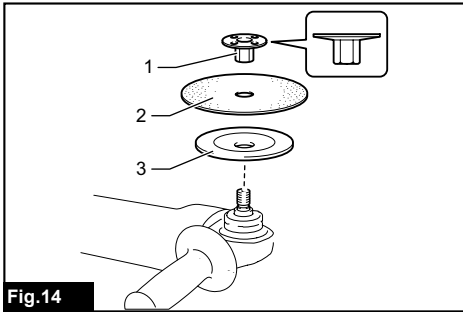

Fig. 14

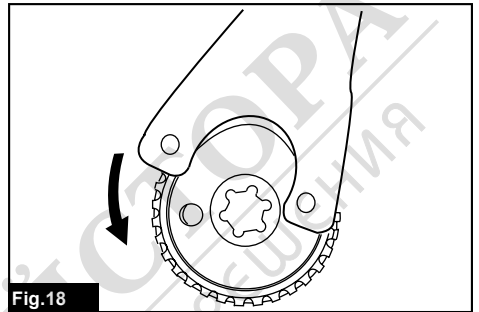

Fig. 18

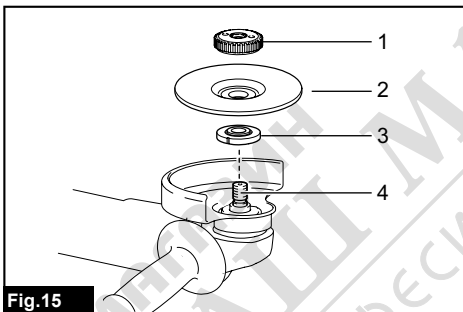

Fig. 15

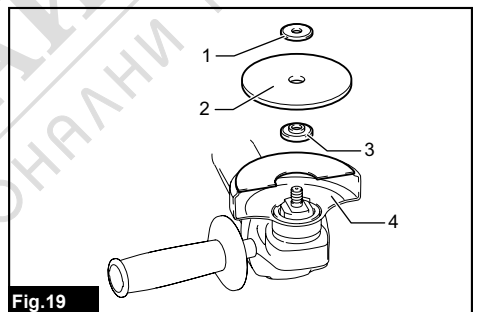

Fig. 19

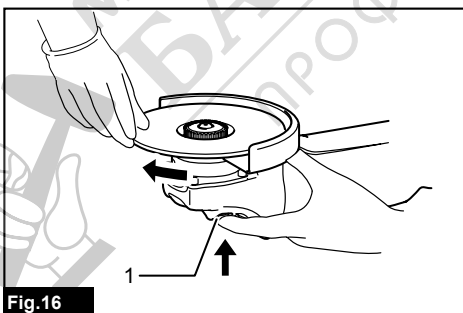

Fig. 16

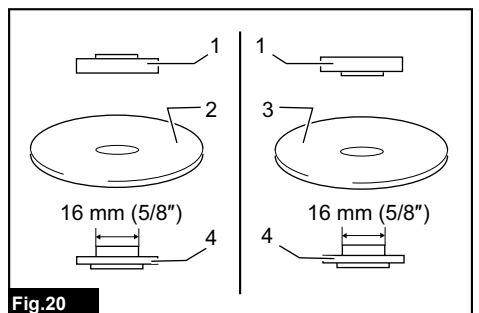
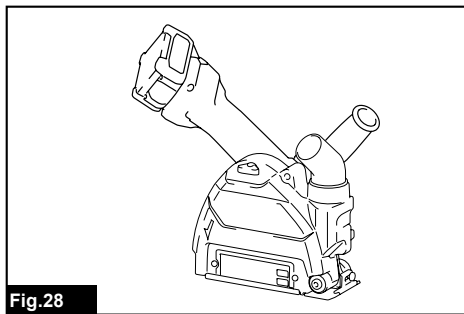
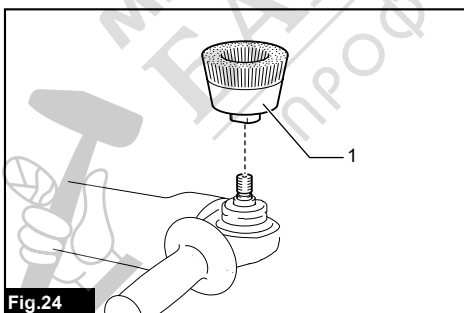
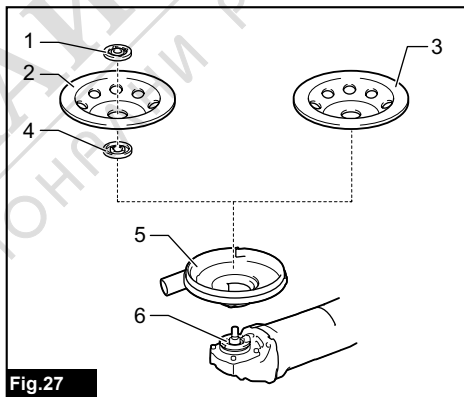
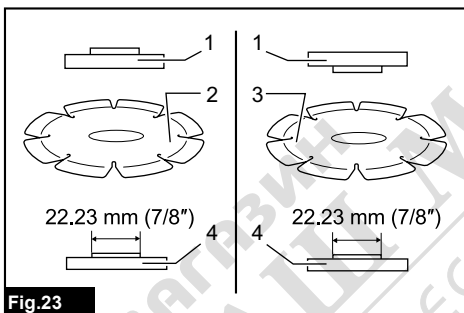
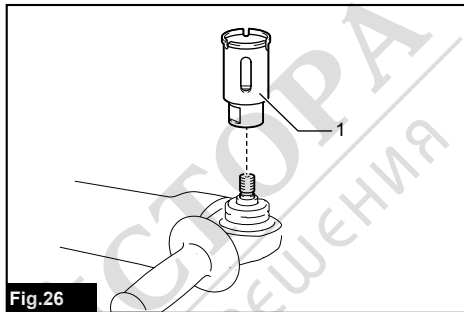
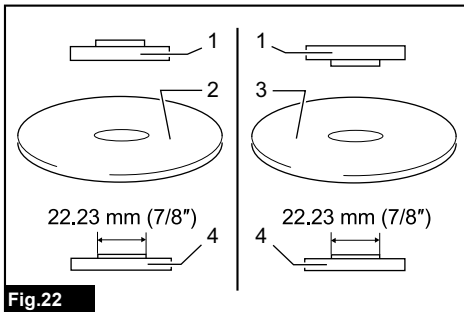
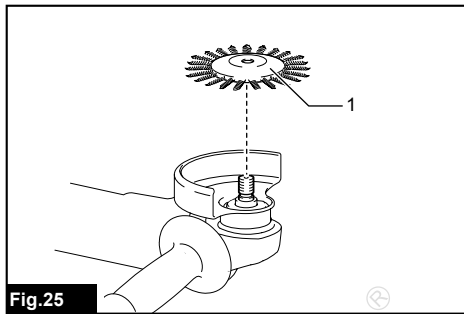
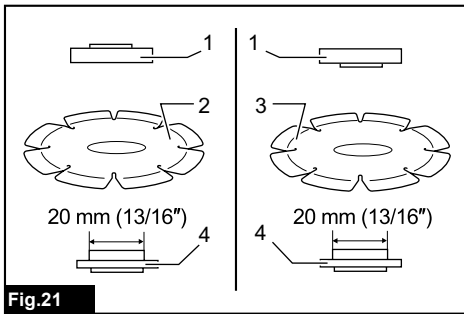

Fig. 20



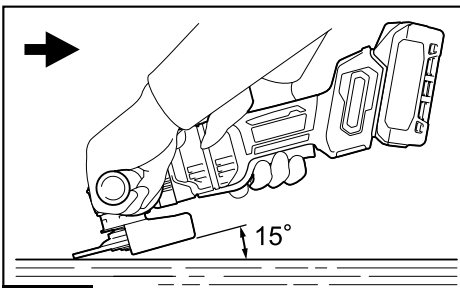

Fig. 29

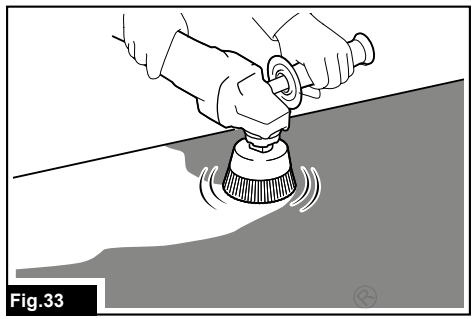

Fig. 33

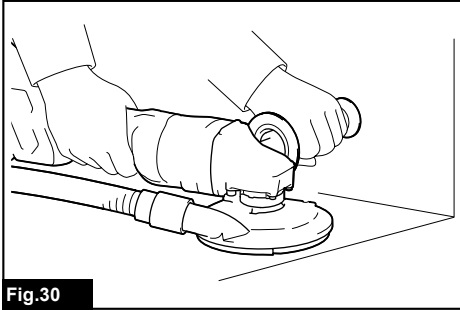

Fig. 30

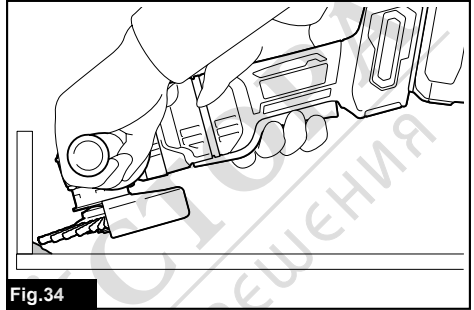

Fig. 34

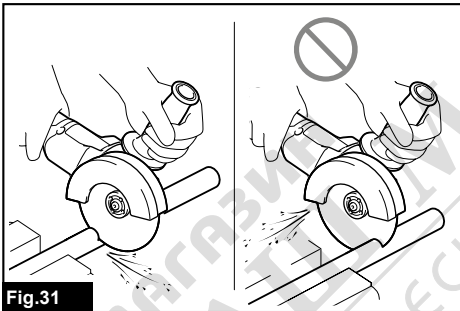

Fig. 31

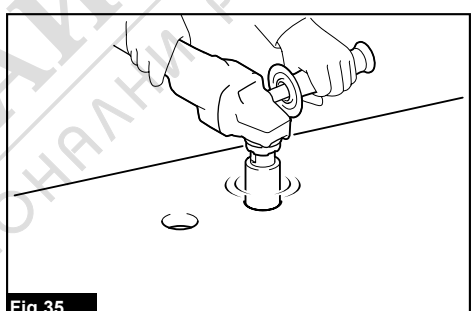

Fig. 35

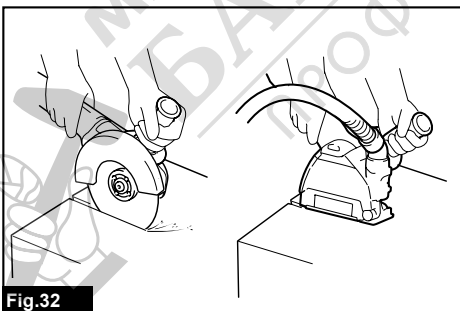

Fig. 32

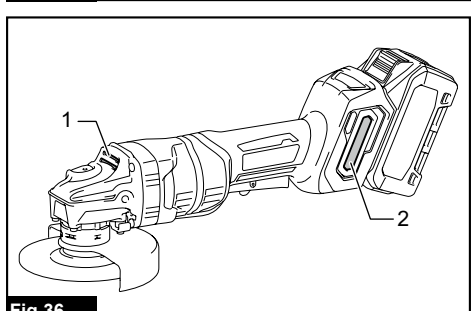

Fig. 36

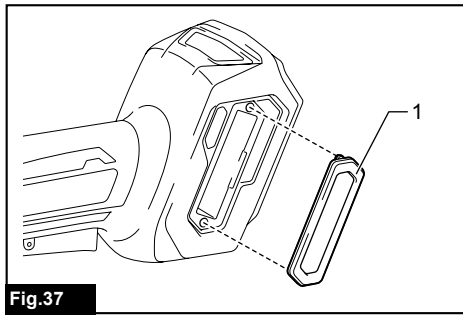

Fig.37



МАГАЗИН
БАШ МАЙСТОРА[®]
ПРОФЕСИОНАЛНИ РЕШЕНИЯ

SPECIFICATIONS

Model:		GA048G	GA049G	GA050G	GA051G
Applicable grinding wheel	Max. wheel diameter	100 mm	115 mm	125 mm	150 mm
	Max. wheel thickness	6.4 mm	7.2 mm		6.4 mm
Applicable cut-off wheel	Max. wheel diameter	105 mm	115 mm	125 mm	150 mm
	Max. wheel thickness	3.2 mm			3.0 mm
Applicable wire wheel brush	Max. wheel diameter	100 mm	115 mm	125 mm	
	Max. wheel thickness	20 mm			
Spindle thread		M10	M14 or 5/8" (country specific)		
Max. spindle length		18 mm	23 mm		
No load speed (n ₀) / Rated speed (n)		11,000 min ⁻¹			9,000 min ⁻¹
Overall length (with BL4040)		410 mm			
Net weight		2.8 - 5.2 kg	3.0 - 5.4 kg		3.1 - 4.7 kg
Rated voltage		D.C. 36 V - 40 V max			

- Due to our continuing program of research and development, the specifications herein are subject to change without notice.
- Specifications may differ from country to country.
- The weight may differ depending on the attachment(s), including the battery cartridge. The lightest and heaviest combinations, according to EPTA-Procedure 01/2014, are shown in the table.

Applicable battery cartridge and charger

Battery cartridge	BL4020 / BL4025* / BL4040* / BL4050F* / BL4080F *: Recommended battery
Charger	DC40RA / DC40RB / DC40RC

- Some of the battery cartridges and chargers listed above may not be available depending on your region of residence.

⚠ WARNING: Only use the battery cartridges and chargers listed above. Use of any other battery cartridges and chargers may cause injury and/or fire.

Recommended cord connected power source

Portable power pack	PDC01 / PDC1200
---------------------	-----------------

- The cord connected power source(s) listed above may not be available depending on your region of residence.
- Before using the cord connected power source, read instruction and cautionary markings on them.

Symbols

The followings show the symbols which may be used for the equipment. Be sure that you understand their meaning before use.



Read instruction manual.



Wear safety glasses.



Always operate with two hands.



Do not use the wheel guard for cut-off operations.



Only for EU countries

Due to the presence of hazardous components in the equipment, waste electrical and electronic equipment, accumulators and batteries may have a negative impact on the environment and human health.

Do not dispose of electrical and electronic appliances or batteries with household waste! In accordance with the European Directive on waste electrical and electronic equipment and on accumulators and batteries and waste accumulators and batteries, as well as their adaptation to national law, waste electrical equipment, batteries and accumulators should be stored separately and delivered to a separate collection point for municipal waste, operating in accordance with the regulations on environmental protection.

This is indicated by the symbol of the crossed-out wheeled bin placed on the equipment.

Intended use

The tool is intended for grinding, sanding, wire brushing, hole cutting and cutting of metal and stone materials without the use of water.

Noise

The typical A-weighted noise level determined according to EN62841-2-3:

Model	Sound pressure level (L_{pA}) : (dB(A))	Sound power level (L_{WA}) : (dB(A))	Uncertainty (K) : (dB(A))
GA048G	84	92	3
GA049G	85	93	3
GA050G	85	93	3
GA051G	85	93	3

NOTE: The declared noise emission value(s) has been measured in accordance with a standard test method and may be used for comparing one tool with another.

NOTE: The declared noise emission value(s) may also be used in a preliminary assessment of exposure.

⚠ WARNING: Wear ear protection.

⚠ WARNING: The noise emission during actual use of the power tool can differ from the declared value(s) depending on the ways in which the tool is used especially what kind of workpiece is processed.

⚠ WARNING: Be sure to identify safety measures to protect the operator that are based on an estimation of exposure in the actual conditions of use (taking account of all parts of the operating cycle such as the times when the tool is switched off and when it is running idle in addition to the trigger time).

⚠ WARNING: Grinding thin sheets of metal or other easily vibrating structures with a large surface can result in a total noise emission much higher (up to 15 dB) than the declared noise emission values.

Set heavy flexible damping mats or such to those workpieces to prevent them from emitting sound.

Take the increased noise emission into consideration for both the risk assessment of noise exposure and selecting adequate hearing protection.

Vibration

The vibration total value (tri-axial vector sum) determined according to EN62841-2-3:

Work mode: surface grinding with normal side grip

Model	Vibration emission ($a_{h, AG}$) : (m/s^2)	Uncertainty (K) : (m/s^2)
GA048G	8.2	1.5
GA049G	8.5	1.5
GA050G	8.9	2.2
GA051G	12.1	1.5

Work mode: surface grinding with anti vibration side grip

Model	Vibration emission ($a_{h, AG}$) : (m/s^2)	Uncertainty (K) : (m/s^2)
GA048G	7.1	1.5
GA049G	7.7	1.5
GA050G	8.8	1.5
GA051G	12.7	1.6

Work mode: disc sanding with normal side grip

Model	Vibration emission ($a_{h, DS}$) : (m/s^2)	Uncertainty (K) : (m/s^2)
GA048G	2.5 m/s^2 or less	1.5
GA049G	2.8	1.5
GA050G	2.6	1.5
GA051G	3.1	1.5

Work mode: disc sanding with anti vibration side grip

Model	Vibration emission ($a_{w, D5}$) : (m/s ²)	Uncertainty (K) : (m/s ²)
GA048G	2.5 m/s ² or less	1.5
GA049G	2.8	1.5
GA050G	2.5	1.5
GA051G	3.5	1.5

NOTE: The declared vibration total value(s) has been measured in accordance with a standard test method and may be used for comparing one tool with another.

NOTE: The declared vibration total value(s) may also be used in a preliminary assessment of exposure.

⚠WARNING: The vibration emission during actual use of the power tool can differ from the declared value(s) depending on the ways in which the tool is used especially what kind of workpiece is processed.

⚠WARNING: Be sure to identify safety measures to protect the operator that are based on an estimation of exposure in the actual conditions of use (taking account of all parts of the operating cycle such as the times when the tool is switched off and when it is running idle in addition to the trigger time).

⚠WARNING: The declared vibration emission value is used for main applications of the power tool. However if the power tool is used for other applications, the vibration emission value may be different.

Declarations of Conformity

For European countries only

The Declarations of conformity are included in Annex A to this instruction manual.

SAFETY WARNINGS

General power tool safety warnings

⚠WARNING Read all safety warnings, instructions, illustrations and specifications provided with this power tool. Failure to follow all instructions listed below may result in electric shock, fire and/or serious injury.

Save all warnings and instructions for future reference.

The term "power tool" in the warnings refers to your mains-operated (corded) power tool or battery-operated (cordless) power tool.

Cordless grinder safety warnings

Safety warnings common for grinding, sanding, wire brushing, or cutting-off operations:

1. This power tool is intended to function as a grinder, sander, wire brush, hole cutter or cut-off tool. Read all safety warnings, instructions, illustrations and specifications provided with this power tool. Failure to follow all instructions listed below may result in electric shock, fire and/or serious injury.
2. Operations such as polishing are not to be performed with this power tool. Operations for which the power tool was not designed may create a hazard and cause personal injury.
3. Do not convert this power tool to operate in a way which is not specifically designed and specified by the tool manufacturer. Such a conversion may result in a loss of control and cause serious personal injury.
4. Do not use accessories which are not specifically designed and specified by the tool manufacturer. Just because the accessory can be attached to your power tool, it does not assure safe operation.
5. The rated speed of the accessory must be at least equal to the maximum speed marked on the power tool. Accessories running faster than their rated speed can break and fly apart.
6. The outside diameter and the thickness of your accessory must be within the capacity rating of your power tool. Incorrectly sized accessories cannot be adequately guarded or controlled.
7. The dimensions of the accessory mounting must fit the dimensions of the mounting hardware of the power tool. Accessories that do not match the mounting hardware of the power tool will run out of balance, vibrate excessively and may cause loss of control.
8. Do not use a damaged accessory. Before each use inspect the accessory such as abrasive wheels for chips and cracks, backing pad for cracks, tear or excess wear, wire brush for loose or cracked wires. If power tool or accessory is dropped, inspect for damage or install an undamaged accessory. After inspecting and installing an accessory, position yourself and bystanders away from the plane of the rotating accessory and run the power tool at maximum no-load speed for one minute. Damaged accessories will normally break apart during this test time.
9. Wear personal protective equipment. Depending on application, use face shield, safety goggles or safety glasses. As appropriate, wear dust mask, hearing protectors, gloves and workshop apron capable of stopping small abrasive or workpiece fragments. The eye protection must be capable of stopping flying debris generated by various applications. The dust mask or respirator must be capable of filtering particles generated by the particular application. Prolonged exposure to high intensity noise may cause hearing loss.

10. **Keep bystanders a safe distance away from work area. Anyone entering the work area must wear personal protective equipment.** Fragments of workpiece or of a broken accessory may fly away and cause injury beyond immediate area of operation.
11. **Hold the power tool by insulated gripping surfaces only, when performing an operation where the cutting tool may contact hidden wiring.** Contact with a "live" wire will also make exposed metal parts of the power tool "live" and could give the operator an electric shock.
12. **Never lay the power tool down until the accessory has come to a complete stop.** The spinning accessory may grab the surface and pull the power tool out of your control.
13. **Do not run the power tool while carrying it at your side.** Accidental contact with the spinning accessory could snag your clothing, pulling the accessory into your body.
14. **Regularly clean the power tool's air vents.** The motor's fan will draw the dust inside the housing and excessive accumulation of powdered metal may cause electrical hazards.
15. **Do not operate the power tool near flammable materials.** Sparks could ignite these materials.
16. **Do not use accessories that require liquid coolants.** Using water or other liquid coolants may result in electrocution or shock.

Kickback and related warnings:

Kickback is a sudden reaction to a pinched or snagged rotating wheel, backing pad, brush or any other accessory. Pinching or snagging causes rapid stalling of the rotating accessory which in turn causes the uncontrolled power tool to be forced in the direction opposite of the accessory's rotation at the point of the binding. For example, if an abrasive wheel is snagged or pinched by the workpiece, the edge of the wheel that is entering into the pinch point can dig into the surface of the material causing the wheel to climb out or kick out. The wheel may either jump toward or away from the operator, depending on direction of the wheel's movement at the point of pinching. Abrasive wheels may also break under these conditions.

Kickback is the result of power tool misuse and/or incorrect operating procedures or conditions and can be avoided by taking proper precautions as given below.

1. **Maintain a firm grip with both hands on the power tool and position your body and arms to allow you to resist kickback forces. Always use auxiliary handle, if provided, for maximum control over kickback or torque reaction during start-up.** The operator can control torque reactions or kickback forces, if proper precautions are taken.
2. **Never place your hand near the rotating accessory.** Accessory may kickback over your hand.
3. **Do not position your body in the area where power tool will move if kickback occurs.** Kickback will propel the tool in direction opposite to the wheel's movement at the point of snagging.
4. **Use special care when working corners, sharp edges, etc. Avoid bouncing and snagging the accessory.** Corners, sharp edges or bouncing have a tendency to snag the rotating accessory and cause loss of control or kickback.

5. **Do not attach a saw chain woodcarving blade, segmented diamond wheel with a peripheral gap greater than 10 mm or toothed saw blade.** Such blades create frequent kickback and loss of control.

Safety warnings specific for grinding and cutting-off operations:

1. **Use only wheel types that are specified for your power tool and the specific guard designed for the selected wheel.** Wheels for which the power tool was not designed cannot be adequately guarded and are unsafe.
2. **The grinding surface of centre depressed wheels must be mounted below the plane of the guard lip.** An improperly mounted wheel that projects through the plane of the guard lip cannot be adequately protected.
3. **The guard must be securely attached to the power tool and positioned for maximum safety, so the least amount of wheel is exposed towards the operator.** The guard helps to protect the operator from broken wheel fragments, accidental contact with wheel and sparks that could ignite clothing.
4. **Wheels must be used only for specified applications. For example: do not grind with the side of cut-off wheel.** Abrasive cut-off wheels are intended for peripheral grinding, side forces applied to these wheels may cause them to shatter.
5. **Always use undamaged wheel flanges that are of correct size and shape for your selected wheel.** Proper wheel flanges support the wheel thus reducing the possibility of wheel breakage. Flanges for cut-off wheels may be different from grinding wheel flanges.
6. **Do not use worn down wheels from larger power tools.** A wheel intended for the higher speed of a smaller tool and may burst.
7. **When using dual purpose wheels always use the correct guard for the application being performed.** Failure to use the correct guard may not provide the desired level of guarding, which could lead to serious injury.

Additional safety warnings specific for cutting-off operations:

1. **Do not "jam" the cut-off wheel or apply excessive pressure. Do not attempt to make an excessive depth of cut.** Overstressing the wheel increases the loading and susceptibility to twisting or binding of the wheel in the cut and the possibility of kickback or wheel breakage.
2. **Do not position your body in line with and behind the rotating wheel.** When the wheel, at the point of operation, is moving away from your body, the possible kickback may propel the spinning wheel and the power tool directly at you.
3. **When the wheel is binding or when interrupting a cut for any reason, switch off the power tool and hold it motionless until the wheel comes to a complete stop. Never attempt to remove the cut-off wheel from the cut while the wheel is in motion otherwise kickback may occur.** Investigate and take corrective action to eliminate the cause of wheel binding.

4. **Do not restart the cutting operation in the workpiece. Let the wheel reach full speed and carefully re-enter the cut.** The wheel may bind, walk up or kickback if the power tool is restarted in the workpiece.
5. **Support panels or any oversized workpiece to minimize the risk of wheel pinching and kickback.** Large workpieces tend to sag under their own weight. Supports must be placed under the workpiece near the line of cut and near the edge of the workpiece on both sides of the wheel.
6. **Use extra caution when making a “pocket cut” into existing walls or other blind areas.** The protruding wheel may cut gas or water pipes, electrical wiring or objects that can cause kickback.
7. **Do not attempt to do curved cutting.** Overstressing the wheel increases the loading and susceptibility to twisting or binding of the wheel in the cut and the possibility of kickback or wheel breakage, which can lead to serious injury.
8. **Before using a segmented diamond wheel, make sure that the diamond wheel has the peripheral gap between segments of 10 mm or less, only with a negative rake angle.**
7. **Do not leave the tool running. Operate the tool only when hand-held.**
8. **Do not touch the workpiece immediately after operation; it may be extremely hot and could burn your skin.**
9. **Do not touch accessories immediately after operation; it may be extremely hot and could burn your skin.**
10. **Observe the instructions of the manufacturer for correct mounting and use of wheels and accessories.** Incorrect mounting and use may result in personal injury.
11. **Handle and store wheels with care.** 
12. **Do not use separate reducing bushings or adaptors to adapt large hole abrasive wheels.**
13. **Use only flanges specified for this tool.**
14. **For tools intended to be fitted with threaded hole wheel, ensure that the thread in the wheel is long enough to accept the spindle length.**
15. **Check that the workpiece is properly supported.**
16. **Pay attention that the wheel continues to rotate after the tool is switched off.**

Safety warnings specific for sanding operations:

1. **Use proper sized sanding disc paper. Follow manufacturers recommendations, when selecting sanding paper.** Larger sanding paper extending too far beyond the sanding pad presents a laceration hazard and may cause snagging, tearing of the disc or kickback.

Safety warnings specific for wire brushing operations:

1. **Be aware that wire bristles are thrown by the brush even during ordinary operation. Do not overstress the wires by applying excessive load to the brush.** The wire bristles can easily penetrate light clothing and/or skin.
2. **If the use of a guard is specified for wire brushing, do not allow any interference of the wire wheel or brush with the guard.** Wire wheel or brush may expand in diameter due to work load and centrifugal forces.

Additional Safety Warnings:

1. **When using depressed centre grinding wheels, be sure to use only fiberglass-reinforced wheels.**
2. **NEVER USE Stone Cup type wheels with this grinder.** This grinder is not designed for these types of wheels and the use of such a product may result in serious personal injury.
3. **Be careful not to damage the spindle, the flange (especially the installing surface) or the lock nut. Damage to these parts could result in wheel breakage.**
4. **Make sure the wheel is not contacting the workpiece before the switch is turned on.**
5. **Before using the tool on an actual workpiece, let it run for a while. Watch for vibration or wobbling that could indicate poor installation or a poorly balanced wheel.**
6. **Use the specified surface of the wheel to perform the grinding.**

11. **Handle and store wheels with care.** 
12. **Do not use separate reducing bushings or adaptors to adapt large hole abrasive wheels.**
13. **Use only flanges specified for this tool.**
14. **For tools intended to be fitted with threaded hole wheel, ensure that the thread in the wheel is long enough to accept the spindle length.**
15. **Check that the workpiece is properly supported.**
16. **Pay attention that the wheel continues to rotate after the tool is switched off.**
17. **If working place is extremely hot and humid, or badly polluted by conductive dust, use a short-circuit breaker (30 mA) to assure operator safety.**
18. **Do not use the tool on any materials containing asbestos.**
19. **When use cut-off wheel, always work with the dust collecting wheel guard if required by domestic regulation.**
20. **Cutting discs must not be subjected to any lateral pressure.**
21. **Do not use cloth work gloves during operation.** Fibers from cloth gloves may enter the tool, which causes tool breakage.
22. **Before operation, make sure that there is no buried object such as electric pipe, water pipe or gas pipe in the workpiece.** Otherwise, it may cause an electric shock, electrical leakage or gas leak.
23. **If a blotter is attached to the wheel, do not remove it. The diameter of the blotter must be larger than the lock nut, outer flange, and inner flange.**
24. **Before installing a grinding wheel, always check that the blotter part does not have any abnormalities such as chips or cracks.**
25. **Tighten the lock nut properly.** Overtightening the wheel can cause breakage and insufficient tightening can cause fluttering.

SAVE THESE INSTRUCTIONS.

⚠WARNING: DO NOT let comfort or familiarity with product (gained from repeated use) replace strict adherence to safety rules for the subject product. MISUSE or failure to follow the safety rules stated in this instruction manual may cause serious personal injury.

Important safety instructions for battery cartridge

1. **Before using battery cartridge, read all instructions and cautionary markings on (1) battery charger, (2) battery, and (3) product using battery.**
2. **Do not disassemble or tamper with the battery cartridge.** It may result in a fire, excessive heat, or explosion.
3. **If operating time has become excessively shorter, stop operating immediately.** It may result in a risk of overheating, possible burns and even an explosion.
4. **If electrolyte gets into your eyes, rinse them out with clear water and seek medical attention right away.** It may result in loss of your eyesight.
5. **Do not short the battery cartridge:**
 - (1) **Do not touch the terminals with any conductive material.**
 - (2) **Avoid storing battery cartridge in a container with other metal objects such as nails, coins, etc.**
 - (3) **Do not expose battery cartridge to water or rain.**

A battery short can cause a large current flow, overheating, possible burns and even a breakdown.

6. **Do not store and use the tool and battery cartridge in locations where the temperature may reach or exceed 50 °C (122 °F).**
7. **Do not incinerate the battery cartridge even if it is severely damaged or is completely worn out.** The battery cartridge can explode in a fire.
8. **Do not nail, cut, crush, throw, drop the battery cartridge, or hit against a hard object to the battery cartridge.** Such conduct may result in a fire, excessive heat, or explosion.
9. **Do not use a damaged battery.**
10. **The contained lithium-ion batteries are subject to the Dangerous Goods Legislation requirements.**

For commercial transports e.g. by third parties, forwarding agents, special requirement on packaging and labeling must be observed.
For preparation of the item being shipped, consulting an expert for hazardous material is required.
Please also observe possibly more detailed national regulations.
Tape or mask off open contacts and pack up the battery in such a manner that it cannot move around in the packaging.
11. **When disposing the battery cartridge, remove it from the tool and dispose of it in a safe place.** Follow your local regulations relating to disposal of battery.
12. **Use the batteries only with the products specified by Makita.** Installing the batteries to non-compliant products may result in a fire, excessive heat, explosion, or leak of electrolyte.

13. **If the tool is not used for a long period of time, the battery must be removed from the tool.**
14. **During and after use, the battery cartridge may take on heat which can cause burns or low temperature burns.** Pay attention to the handling of hot battery cartridges.
15. **Do not touch the terminal of the tool immediately after use as it may get hot enough to cause burns.**
16. **Do not allow chips, dust, or soil stuck into the terminals, holes, and grooves of the battery cartridge.** It may cause heating, catching fire, burst and malfunction of the tool or battery cartridge, resulting in burns or personal injury.
17. **Unless the tool supports the use near high-voltage electrical power lines, do not use the battery cartridge near high-voltage electrical power lines.** It may result in a malfunction or breakdown of the tool or battery cartridge.
18. **Keep the battery away from children.**

SAVE THESE INSTRUCTIONS.

⚠CAUTION: Only use genuine Makita batteries. Use of non-genuine Makita batteries, or batteries that have been altered, may result in the battery bursting causing fires, personal injury and damage. It will also void the Makita warranty for the Makita tool and charger.

Tips for maintaining maximum battery life

1. **Charge the battery cartridge before completely discharged.** Always stop tool operation and charge the battery cartridge when you notice less tool power.
2. **Never recharge a fully charged battery cartridge.** Overcharging shortens the battery service life.
3. **Charge the battery cartridge with room temperature at 10 °C - 40 °C (50 °F - 104 °F).** Let a hot battery cartridge cool down before charging it.
4. **When not using the battery cartridge, remove it from the tool or the charger.**
5. **Charge the battery cartridge if you do not use it for a long period (more than six months).**

FUNCTIONAL DESCRIPTION

⚠WARNING: Always be sure that the tool is switched off and the battery cartridge is removed before adjusting or checking function on the tool.

Installing or removing battery cartridge

⚠CAUTION: Always switch off the tool before installing or removing of the battery cartridge.

⚠CAUTION: Hold the tool and the battery cartridge firmly when installing or removing battery cartridge. Failure to hold the tool and the battery cartridge firmly may cause them to slip off your hands and result in damage to the tool and battery cartridge and a personal injury.

► **Fig.1:** 1. Red indicator 2. Button 3. Battery cartridge

To remove the battery cartridge, slide it from the tool while sliding the button on the front of the cartridge.

To install the battery cartridge, align the tongue on the battery cartridge with the groove in the housing and slip it into place. Insert it all the way until it locks in place with a little click. If you can see the red indicator as shown in the figure, it is not locked completely.

⚠CAUTION: Always install the battery cartridge fully until the red indicator cannot be seen. If not, it may accidentally fall out of the tool, causing injury to you or someone around you.

⚠CAUTION: Do not install the battery cartridge forcibly. If the cartridge does not slide in easily, it is not being inserted correctly.

Indicating the remaining battery capacity

Press the check button on the battery cartridge to indicate the remaining battery capacity. The indicator lamps light up for a few seconds.

► **Fig.2:** 1. Indicator lamps 2. Check button

Indicator lamps			Remaining capacity
Lighted	Off	Blinking	
■	□	◐	75% to 100%
■ ■ ■ ■	□	□	50% to 75%
■ ■	□ □	□	25% to 50%
■	□ □ □	□	0% to 25%
◐	□ □ □	□	Charge the battery.
■ ■	□ □	□ □	The battery may have malfunctioned.
□ □	■ ■	↑ ↓	

NOTE: Depending on the conditions of use and the ambient temperature, the indication may differ slightly from the actual capacity.

NOTE: The first (far left) indicator lamp will blink when the battery protection system works.

Tool / battery protection system

The tool is equipped with a tool/battery protection system. This system automatically cuts off power to the motor to extend tool and battery life. The tool will automatically stop during operation if the tool or battery is placed under one of the following conditions: ⚠

Overload protection

When the tool/battery is operated in a manner that causes it to draw an abnormally high current, the tool automatically stops without any indication. In this situation, turn the tool off and stop the application that caused the tool to become overloaded. Then turn the tool on to restart.

Overheat protection

When the tool/battery is overheated, the tool stops automatically. Let the tool cool down before turning the tool on again.

Overdischarge protection

When the battery capacity is not enough, the tool stops automatically. In this case, remove the battery from the tool and charge the battery.

Releasing protection lock

When the protection system works repeatedly, the tool is locked.

In this situation, the tool does not start even if turning the tool off and on. To release the protection lock, remove the battery, set it to the battery charger and wait until the charging finishes.

Protections against other causes

Protection system is also designed for other causes that could damage the tool and allows the tool to stop automatically. Take all the following steps to clear the causes, when the tool has been brought to a temporary halt or stop in operation.

1. Turn the tool off, and then turn it on again to restart.
2. Charge the battery(ies) or replace it/them with recharged battery(ies).
3. Let the tool and battery(ies) cool down.

If no improvement can be found by restoring protection system, then contact your local Makita Service Center.

Shaft lock

⚠ WARNING: Never actuate the shaft lock when the spindle is moving. It may cause serious injury or the tool damage.

Press the shaft lock to prevent spindle rotation when installing or removing accessories.

► Fig.3: 1. Shaft lock

Switch action

⚠ CAUTION: Before installing the battery cartridge into the tool, always check to see that the switch lever actuates properly and returns to the "OFF" position when released.

⚠ CAUTION: For your safety, this tool is equipped with lock-off lever which prevents the tool from unintended starting. NEVER use the tool if it runs when you simply pull the switch lever without pulling the lock-off lever. Return the tool to our authorized service center for proper repairs BEFORE further usage.

⚠ CAUTION: Do not pull the switch lever hard without pulling the lock-off lever. This can cause switch breakage.

⚠ CAUTION: NEVER tape down or defeat purpose and function of lock-off lever.

To prevent the switch lever from being accidentally pulled, a lock-off lever is provided.

To start the tool, pull the lock-off lever toward the operator and then pull the switch lever.

To stop the tool, release the switch lever.

► Fig.4: 1. Lock-off lever 2. Switch lever

Accidental re-start preventive function

When installing the battery cartridge while the switch is ON, the tool does not start.

To start the tool, turn off the switch, and turn it on again.

Active Feedback sensing Technology

The tool electronically detects situations where the wheel or accessory may be at risk to be bound. In the situation, the tool is automatically shut off to prevent further rotation of the spindle (it does not prevent kickback).

To restart the tool, switch off the tool first, remove the cause of sudden drop in the rotation speed, and then turn the tool on.

Soft start feature

Soft start feature reduces starting reaction.

Electric brake

Electric brake is activated after the tool is switched off. The brake does not work when the power supply is shut down, such as the battery is removed accidentally, with the switch still on.

ASSEMBLY

⚠ WARNING: Always be sure that the tool is switched off and the battery cartridge is removed before adjusting or checking function on the tool.

Installing side grip (handle)

⚠ CAUTION: Always be sure that the side grip is installed securely before operation.

Screw the side grip securely on the position of the tool as shown in the figure.

► Fig.5

Installing or removing wheel guard

⚠ WARNING: When using a depressed center wheel, flap disc, flex wheel or wire wheel brush, the wheel guard must be fitted on the tool so that the closed side of the guard always points toward the operator.

⚠ WARNING: Make sure that the wheel guard is securely locked by the lock lever with one of the holes on the wheel guard.

⚠ WARNING: When using an abrasive cut-off / diamond wheel, be sure to use only the special wheel guard designed for use with cut-off wheels.

For depressed center wheel, flap disc, flex wheel, wire wheel brush / abrasive cut-off wheel, diamond wheel

1. While pushing the lock lever, mount the wheel guard with the protrusions on the wheel guard aligned with the notches on the bearing box.

► Fig.6: 1. Lock lever 2. Notch 3. Protrusion

2. While pushing the lock lever toward A, hold down the portions B of the wheel guard as shown in the figure.

► Fig.7: 1. Wheel guard 2. Hole

NOTE: Push down the wheel guard straight. Otherwise, you cannot secure the wheel guard.

3. While pushing the lock lever toward A, rotate the wheel guard toward C, and then, change the angle of the wheel guard according to the work so that the operator can be protected. Align the lock lever with one of the holes in the wheel guard, and then release the lock lever to lock the wheel guard.

► Fig.8: 1. Wheel guard 2. Hole

To remove wheel guard, follow the installation procedure in reverse.

Clip-on cutting wheel guard attachment

Optional accessory

NOTE: For cutting-off operations, a clip-on cutting wheel guard attachment can be used with the wheel guard (for grinding wheel).

Not available in some countries.

► Fig.9

Installing or removing depressed center wheel or flap disc

Optional accessory

⚠WARNING: When using a depressed center wheel or flap disc, the wheel guard must be fitted on the tool so that the closed side of the guard always points toward the operator.

⚠WARNING: Make sure that the mounting part of the inner flange fits into the inner diameter of the depressed center wheel / flap disc perfectly. Mounting the inner flange on the wrong side may result in the dangerous vibration.

Mount the inner flange onto the spindle. Make sure to fit the dented part of the inner flange onto the straight part at the bottom of the spindle. Fit the depressed center wheel / flap disc on the inner flange and screw the lock nut onto the spindle.

► Fig.10: 1. Lock nut 2. Depressed center wheel 3. Inner flange 4. Mounting part

To tighten the lock nut, press the shaft lock firmly so that the spindle cannot revolve, then use the lock nut wrench and securely tighten clockwise.

► Fig.11: 1. Lock nut wrench 2. Shaft lock

To remove the wheel, follow the installation procedure in reverse.

Installing or removing flex wheel

Optional accessory

⚠WARNING: Always use supplied guard when flex wheel is on the tool. Wheel can shatter during use and guard helps to reduce chances of personal injury.

► Fig.12: 1. Lock nut 2. Flex wheel 3. Back up pad 4. Inner flange

Follow instructions for depressed center wheel but also use back up pad over wheel.

Installing or removing abrasive disc

Optional accessory

NOTE: Use sander accessories specified in this manual. These must be purchased separately.

For 100 mm (4") model

► Fig.13: 1. Sanding lock nut 2. Abrasive disc 3. Rubber pad 4. Inner flange

1. Mount the inner flange onto the spindle.
2. Mount the rubber pad onto the spindle.
3. Fit the disc on the rubber pad and screw the sanding lock nut onto the spindle.
4. Hold the spindle with the shaft lock, and securely tighten the sanding lock nut clockwise with the lock nut wrench.

To remove the disc, follow the installation procedure in reverse.

For model other than 100 mm (4")

► Fig.14: 1. Sanding lock nut 2. Abrasive disc 3. Rubber pad

1. Mount the rubber pad onto the spindle.
2. Fit the disc on the rubber pad and screw the sanding lock nut onto the spindle.
3. Hold the spindle with the shaft lock, and securely tighten the sanding lock nut clockwise with the lock nut wrench.

To remove the disc, follow the installation procedure in reverse.

Installing or removing Ezynut

Optional accessory

Only for tools with M14 spindle thread.

Mount inner flange, abrasive wheel and Ezynut onto the spindle so that Makita Logo on Ezynut faces outside.

► Fig.15: 1. Ezynut 2. Abrasive wheel 3. Inner flange 4. Spindle

Press shaft lock firmly and tighten Ezynut by turning the abrasive wheel clockwise as far as it turns.

► Fig.16: 1. Shaft lock

To loosen the Ezynut, turn the outside ring of Ezynut counterclockwise.

NOTE: Ezynut can be loosened by hand as long as the arrow points the notch. Otherwise a lock nut wrench is required to loosen it. Insert one pin of the wrench into a hole and turn Ezynut counterclockwise.

► Fig.17: 1. Arrow 2. Notch

► Fig.18

Installing abrasive cut-off / diamond wheel

Optional accessory

⚠WARNING: When using an abrasive cut-off / diamond wheel, be sure to use only the special wheel guard designed for use with cut-off wheels.

⚠WARNING: NEVER use cut-off wheel for side grinding.

⚠CAUTION: When installing the diamond wheel, be sure to align the direction of the arrow on the wheel with the arrow on the tool.

► Fig.19: 1. Lock nut 2. Abrasive cut-off wheel / diamond wheel 3. Inner flange 4. Wheel guard for abrasive cut-off wheel / diamond wheel

As for the installation, follow the instructions for depressed center wheel.

The direction for mounting the lock nut and the inner flange varies by wheel type and thickness.

Refer to the following figures.

For 100 mm (4") model

When installing the abrasive cut-off wheel:

- **Fig.20:** 1. Lock nut 2. Abrasive cut-off wheel (Thinner than 4 mm (5/32")) 3. Abrasive cut-off wheel (4 mm (5/32") or thicker) 4. Inner flange

When installing the diamond wheel:

- **Fig.21:** 1. Lock nut 2. Diamond wheel (Thinner than 4 mm (5/32")) 3. Diamond wheel (4 mm (5/32") or thicker) 4. Inner flange

For model other than 100 mm (4")

When installing the abrasive cut-off wheel:

- **Fig.22:** 1. Lock nut 2. Abrasive cut-off wheel (Thinner than 4 mm (5/32")) 3. Abrasive cut-off wheel (4 mm (5/32") or thicker) 4. Inner flange

When installing the diamond wheel:

- **Fig.23:** 1. Lock nut 2. Diamond wheel (Thinner than 4 mm (5/32")) 3. Diamond wheel (4 mm (5/32") or thicker) 4. Inner flange

Installing wire cup brush

Optional accessory

CAUTION: Do not use wire cup brush that is damaged, or which is out of balance. Use of damaged wire cup brush could increase potential for injury from contact with broken brush wires.

Place the tool upside down to allow easy access to the spindle.

Remove any accessories on spindle. Thread wire cup brush onto spindle and tighten with supplied wrench.

- **Fig.24:** 1. Wire cup brush

Installing wire wheel brush

Optional accessory

CAUTION: Do not use wire wheel brush that is damaged, or which is out of balance. Use of damaged wire wheel brush could increase potential for injury from contact with broken wires.

CAUTION: ALWAYS use guard with wire wheel brushes, assuring diameter of wheel fits inside guard. Wheel can shatter during use and guard helps to reduce chances of personal injury.

Place the tool upside down to allow easy access to the spindle.

Remove any accessories on spindle. Thread wire wheel brush onto spindle and tighten with the wrenches.

- **Fig.25:** 1. Wire wheel brush

Installing hole cutter

Optional accessory

Place the tool upside down to allow easy access to the spindle.

Remove any accessories on the spindle. Thread the hole cutter onto the spindle, and tighten it with the supplied wrench.

- **Fig.26:** 1. Hole cutter

Installing dust collecting wheel guard for grinding

Only for model GA049G / GA050G

Optional accessory

With optional accessories, you can use this tool for planing concrete surface.

CAUTION: Dust collecting wheel guard for grinding is only for use in planing concrete surface with a cup-type diamond wheel. Do not use this guard with any other cutting accessory or for any other purpose.

CAUTION: Before operation, make sure that a vacuum cleaner is connected to the tool and turned on.

Place the tool upside down and install the dust collecting wheel guard.

Mount the inner flange onto the spindle.

Fit the cup-type diamond wheel on the inner flange and tighten the lock nut onto the spindle.

- **Fig.27:** 1. Lock nut 2. Cup-type diamond wheel 3. Hubbed cup-type diamond wheel 4. Inner flange 5. Dust collecting wheel guard 6. Bearing box

NOTE: For information how to install the dust collecting wheel guard, refer to the manual of the dust collecting wheel guard.

Installing dust collecting wheel guard for cutting-off

Only for model GA048G / GA049G / GA050G

Optional accessory

With optional accessories, you can use this tool for cutting stone materials.

- **Fig.28**

NOTE: For information how to install the dust collecting wheel guard, refer to the manual of the dust collecting wheel guard.

OPERATION

⚠WARNING: It should never be necessary to force the tool. The weight of the tool applies adequate pressure. Forcing and excessive pressure could cause dangerous wheel breakage.

⚠WARNING: ALWAYS replace wheel if tool is dropped while grinding.

⚠WARNING: NEVER hit the workpiece with the wheel.

⚠WARNING: Avoid bouncing and snagging the wheel, especially when working corners, sharp edges etc. This can cause loss of control and kickback.

⚠WARNING: NEVER use tool with wood cutting blades and other saw blades. Such blades when used on a grinder frequently kick and cause loss of control leading to personal injury.

⚠CAUTION: Never switch on the tool when it is in contact with the workpiece, it may cause an injury to operator.

⚠CAUTION: Always wear safety goggles or a face shield during operation.

⚠CAUTION: After operation, always switch off the tool and wait until the wheel has come to a complete stop before putting the tool down.

⚠CAUTION: ALWAYS hold the tool firmly with one hand on housing and the other on the side grip (handle).

NOTE: A dual purpose wheel can be used for both grinding and cutting-off operations.

Refer to the "Grinding and sanding operation" for grinding operation, and refer to the "Operation with abrasive cut-off / diamond wheel" for cutting-off operation.

Grinding and sanding operation

► Fig.29

Turn the tool on and then apply the wheel or disc to the workpiece.

In general, keep the edge of the wheel or disc at an angle of about 15° to the workpiece surface.

During the break-in period with a new wheel, do not work the grinder in forward direction or it may cut into the workpiece. Once the edge of the wheel has been rounded off by use, the wheel may be worked in both forward and backward direction.

Usage example: operation with cup-type diamond wheel

► Fig.30

Keep the tool horizontally and apply the entire cup-type diamond wheel to the workpiece surface.

Operation with abrasive cut-off / diamond wheel

Optional accessory

⚠WARNING: Do not "jam" the wheel or apply excessive pressure. Do not attempt to make an excessive depth of cut. Overstressing the wheel increases the loading and susceptibility to twisting or binding of the wheel in the cut and the possibility of kickback, wheel breakage and overheating of the motor may occur.

⚠WARNING: Do not start the cutting operation in the workpiece. Let the wheel reach full speed and carefully enter into the cut moving the tool forward over the workpiece surface. The wheel may bind, walk up or kickback if the power tool is started in the workpiece.

⚠WARNING: During cutting operations, never change the angle of the wheel. Placing side pressure on the cut-off wheel (as in grinding) will cause the wheel to crack and break, causing serious personal injury.

⚠WARNING: A diamond wheel shall be operated perpendicular to the material being cut.

Usage example: operation with abrasive cut-off wheel

► Fig.31

Usage example: operation with diamond wheel

► Fig.32

Operation with wire cup brush

Optional accessory

⚠CAUTION: Check operation of wire cup brush by running tool with no load, insuring that no one is in front of or in line with wire cup brush.

NOTICE: Avoid applying too much pressure which causes over bending of wires when using the wire cup brush. It may lead to premature breakage.

Usage example: operation with wire cup brush

► Fig.33

Operation with wire wheel brush

Optional accessory

⚠CAUTION: Check operation of wire wheel brush by running tool with no load, insuring that no one is in front of or in line with the wire wheel brush.

NOTICE: Avoid applying too much pressure which causes over bending of wires when using wire wheel brush. It may lead to premature breakage.

Usage example: operation with wire wheel brush

► Fig.34

Operation with hole cutter

Optional accessory

⚠ CAUTION: Check operation of the hole cutter by running the tool with no load, insuring that no one is in front of the hole cutter.

NOTICE: Do not tilt the tool during operation. It may lead to premature breakage.

Usage example: operation with hole cutter

► Fig.35

MAINTENANCE

⚠ WARNING: Always be sure that the tool is switched off and the battery cartridge is removed before attempting to perform inspection or maintenance.

NOTICE: Never use gasoline, benzine, thinner, alcohol or the like. Discoloration, deformation or cracks may result.

To maintain product SAFETY and RELIABILITY, repairs, any other maintenance or adjustment should be performed by Makita Authorized or Factory Service Centers, always using Makita replacement parts.

Air vent cleaning

The tool and its air vents have to be kept clean. Regularly clean the tool's air vents or whenever the vents start to become obstructed.

► Fig.36: 1. Exhaust vent 2. Inhalation vent

Remove the dust cover from inhalation vent and clean it for smooth air circulation.

► Fig.37: 1. Dust cover

NOTICE: Clean out the dust cover when it is clogged with dust or foreign matters. Continuing operation with a clogged dust cover may damage the tool.



COMBINATION OF APPLICATIONS AND ACCESSORIES

Optional accessory

⚠ CAUTION: Using the tool with incorrect guards can cause risks as follows.

- When using a cut-off wheel guard for facial grinding, the wheel guard may interfere with the workpiece causing poor control.
- When using a grinding wheel guard for cutting-off operations with bonded abrasive wheels and diamond wheels, there is an increased risk of exposure to rotating wheels, emitted sparks and particles, as well as exposure to wheel fragments in the event of wheel burst.
- When using a cut-off wheel guard or grinding wheel guard for facial operations with cup-type diamond wheels, the wheel guard may interfere with the workpiece causing poor control.
- When using a cut-off wheel guard or grinding wheel guard with a wheel-type wire brush with a thickness greater than the maximum thickness as specified in "SPECIFICATIONS", the wires may catch on the guard leading to breaking of wires.
- Use of dust collecting wheel guards for cutting-off and facial operations in concrete or masonry reduces a risk of exposure to dust.
- When using dual purpose (combined grinding and cutting-off abrasive) flange mounted wheels, only use a cut-off wheel guard.

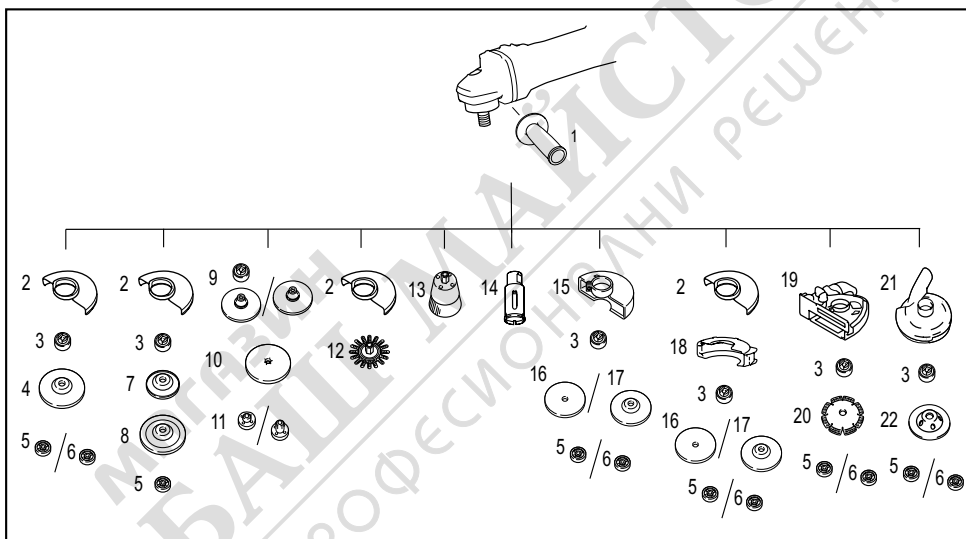

	Application	100 mm model	115 mm model	125 mm model	150 mm model
1	-	Side grip			
2	-	Wheel guard (for grinding wheel)			
3	-	Inner flange			
4	Grinding / Sanding	Depressed center wheel / Flap disc			
5	-	Lock nut			
6	-	-	Ezynut *1		
7	-	Back up pad			
8	Grinding	Flex wheel			
9	-	Inner flange and rubber pad 76	Rubber pad 100	Rubber pad 115	Rubber pad 125
10	Sanding	Abrasive disc			
11	-	Sanding lock nut			
12	Wire brushing	Wire wheel brush			

-	Application	100 mm model	115 mm model	125 mm model	150 mm model
13	Wire brushing	Wire cup brush			
14	Hole cutting	Hole cutter			
15	-	Wheel guard (for cut-off wheel)			
16	Cutting-off	Abrasive cut-off wheel / Diamond wheel			
17	Grinding / Cutting-off	Dual purpose wheel			-
18	-	Clip-on cutting wheel guard attachment *2			
19	-	Dust collecting wheel guard for cutting-off *3			-
20	Cutting-off	Diamond wheel			-
21	-	-	Dust collecting wheel guard for grinding *4		-
22	Grinding	-	Cup-type diamond wheel *4		-
-	-	Lock nut wrench			

NOTE: *1 Only for tools with M14 spindle thread.

NOTE: *2 Clip-on cutting wheel guard attachment is not available in some countries. For more details, refer to the instruction manual of the clip-on cutting wheel guard attachment.

NOTE: *3 Only for model GA048G / GA049G / GA050G

For more details, refer to each instruction manual of the guard.

NOTE: *4 Only for model GA049G / GA050G

For more details, refer to each instruction manual of the guard.

OPTIONAL ACCESSORIES

CAUTION: These accessories or attachments are recommended for use with your Makita tool specified in this manual. The use of any other accessories or attachments might present a risk of injury to persons. Only use accessory or attachment for its stated purpose.

If you need any assistance for more details regarding these accessories, ask your local Makita Service Center.

- Makita genuine battery and charger
- Accessories listed in "COMBINATION OF APPLICATIONS AND ACCESSORIES"

NOTE: Some items in the list may be included in the tool package as standard accessories. They may differ from country to country.

