

D	Originalbetriebsanleitung Akku-Laubsauger	FIN	Alkuperäiskäyttöohje Akkukäyttöinen lehti-imuri
GB	Original operating instructions Cordless blower vac	SLO	Originalna navodila za uporabo Sesalnik za listje na baterije
F	Instructions d'origine Aspirateur de feuilles sans fil	H	Eredeti használati utasítás Akkus-lombszívó
I	Istruzioni per l'uso originali Aspiratore di foglie a batteria	RO	Instrucțiuni de utilizare originale Aspirator de frunze cu acumulator
DK/ N	Original betjeningsvejledning Akku-løvsuger	GR	Πρωτότυπες Οδηγίες χρήσης Ναρροφητής φυλλων, με μπαταρια
S	Original-bruksanvisning Batteridrivnen lövsug	P	Manual de instruções original Aspirador de folhas sem fio
CZ	Originální návod k obsluze Akumulátorový sběrač listí	HR/ BIH	Originalne upute za uporabu Akumulatorski usisavač lišća
SK	Originálny návod na obsluhu Akumulátorový vysávač lístia	RS	Originalna uputstva za upotrebu Akumulatorski usisavač lišća
NL	Originele handleiding Accu-bladzuiger	PL	Instrukcją oryginalną Akumulatorowy odkurzacz do liści
E	Manual de instrucciones original Aspirador de hojas con batería	TR	Orijinal Kullanma Talimatı Akülü yaprak aspiratörü
		EE	Originaalkasutusjuhend Akumootoriga leheimur

13



Art.-Nr.: 34.336.25

I.-Nr.: 21011

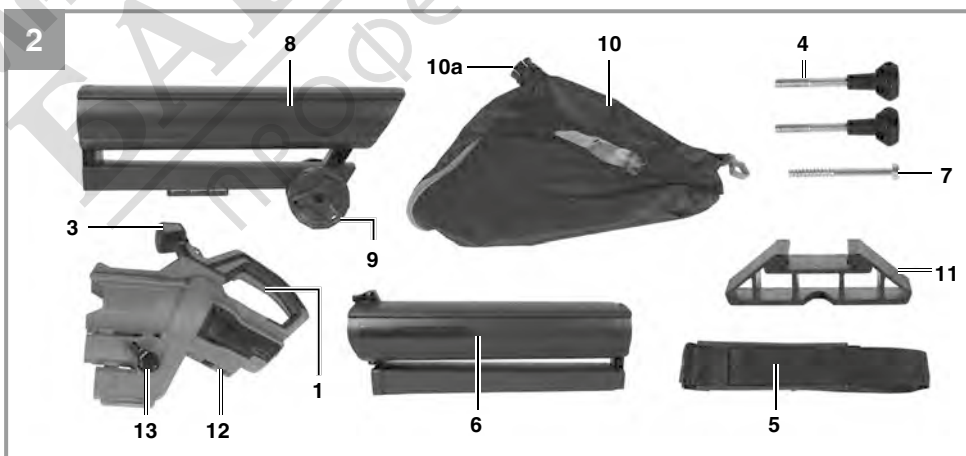
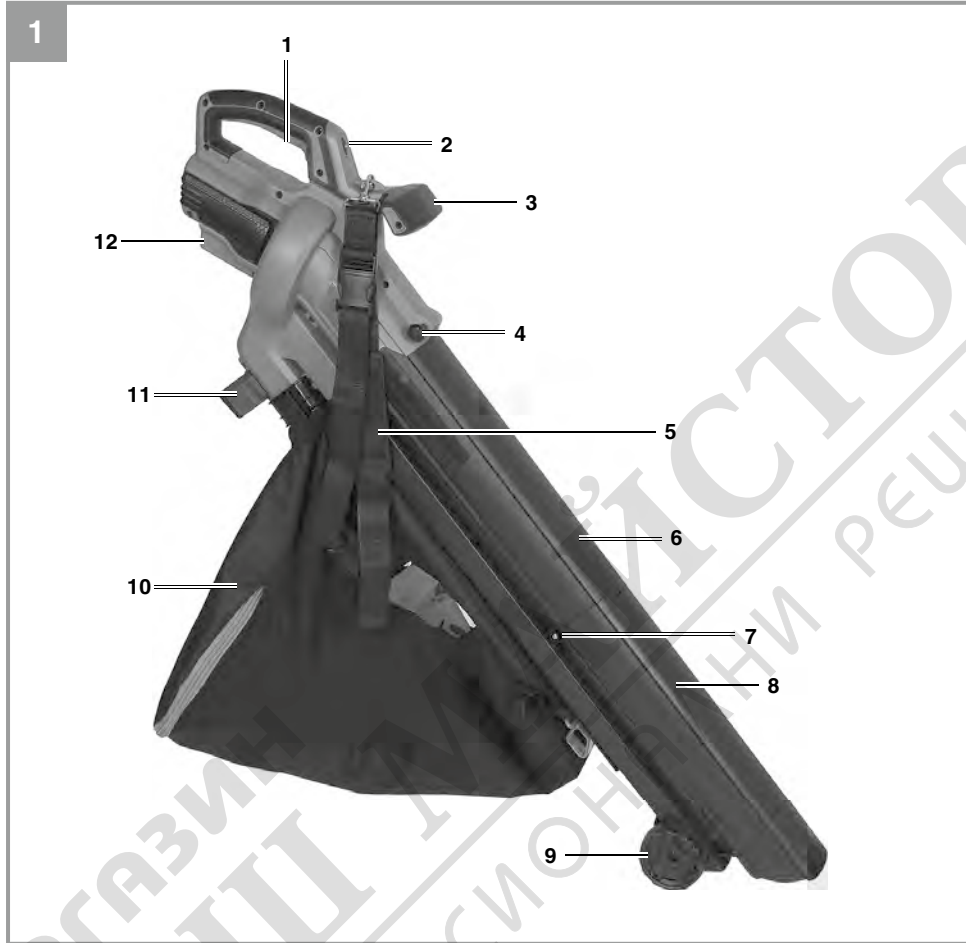

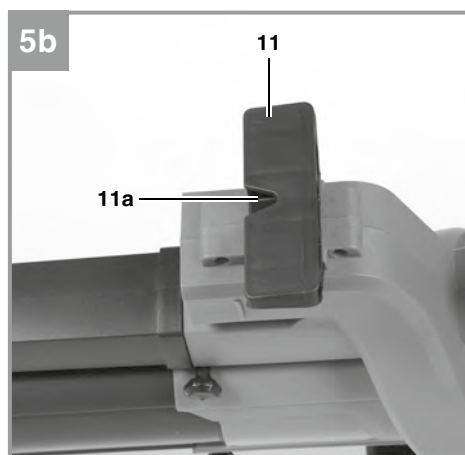
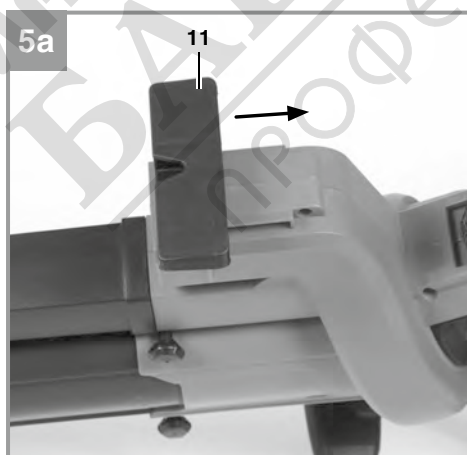
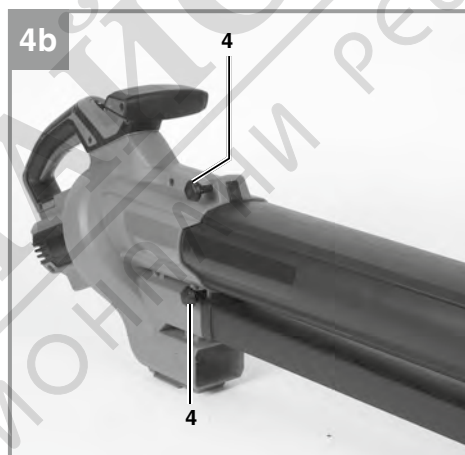
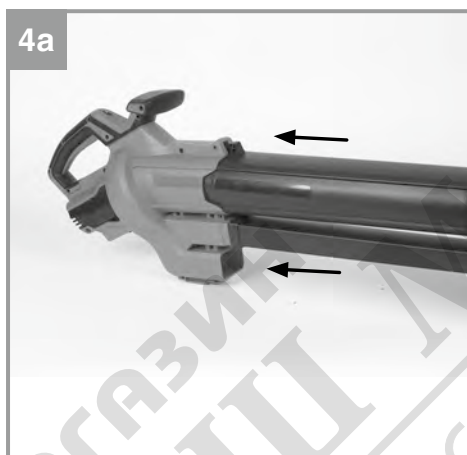
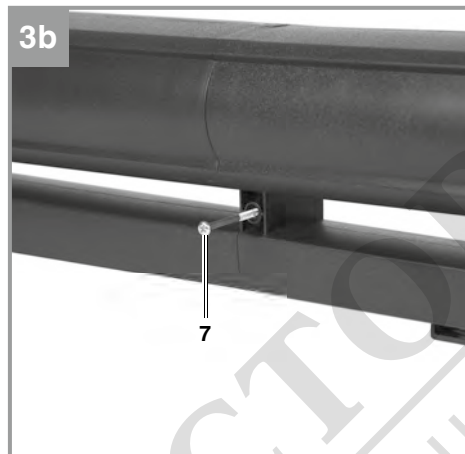
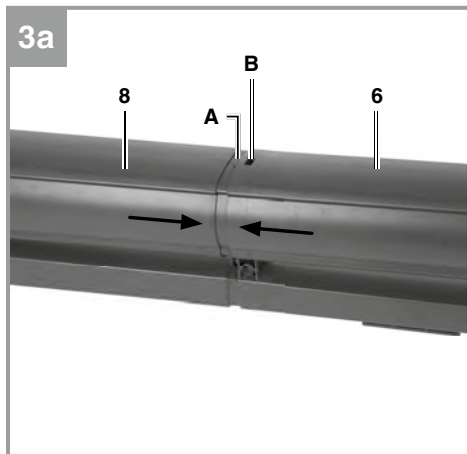

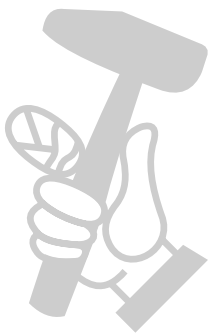
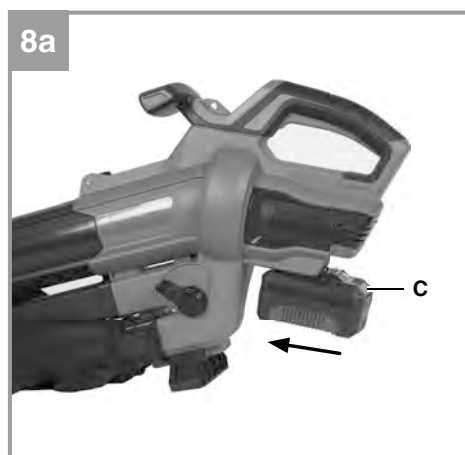
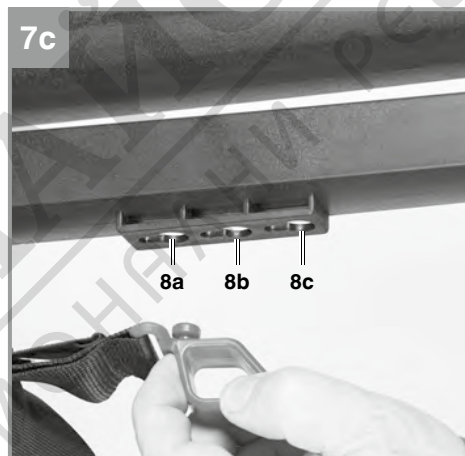
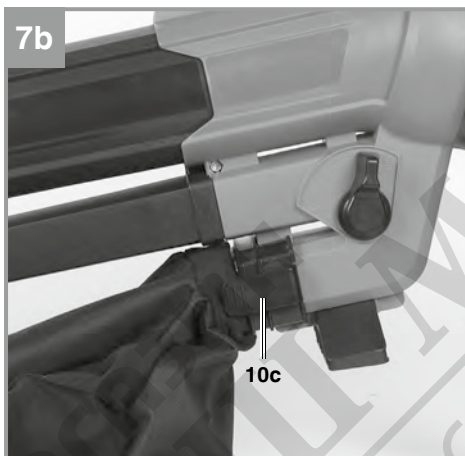
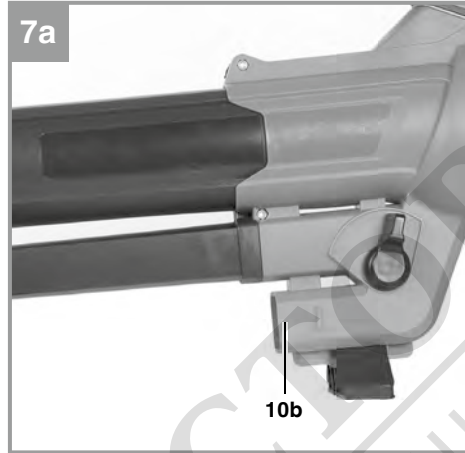
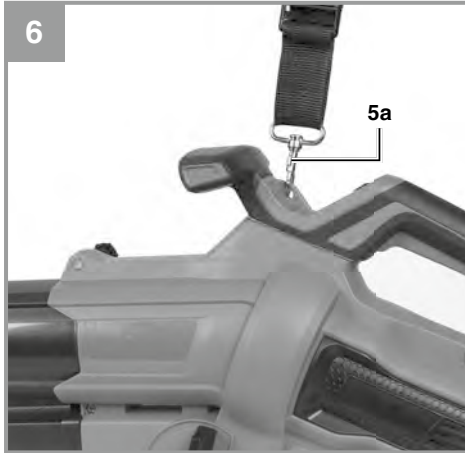

МАШИНЫ И ИНСТРУМЕНТЫ
РЕШЕНИЯ

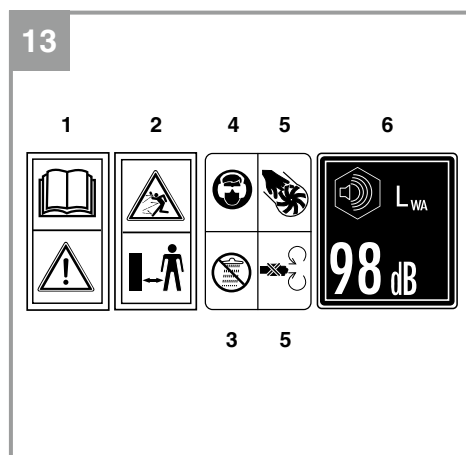
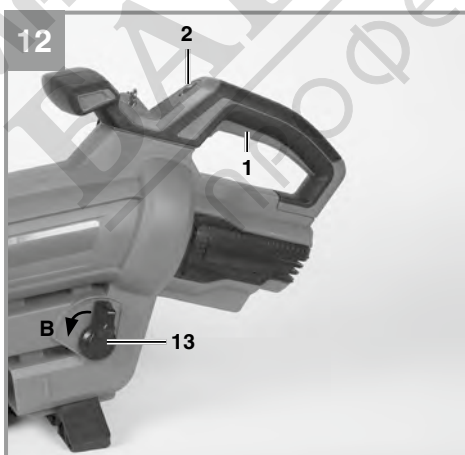
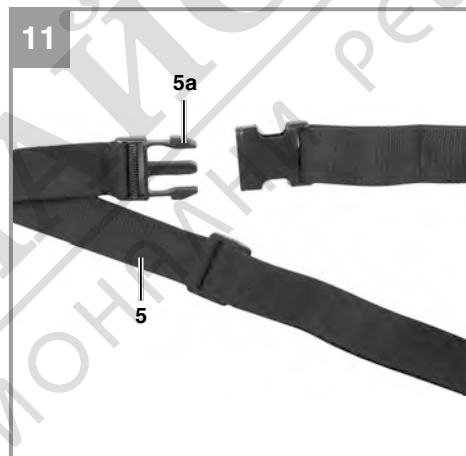
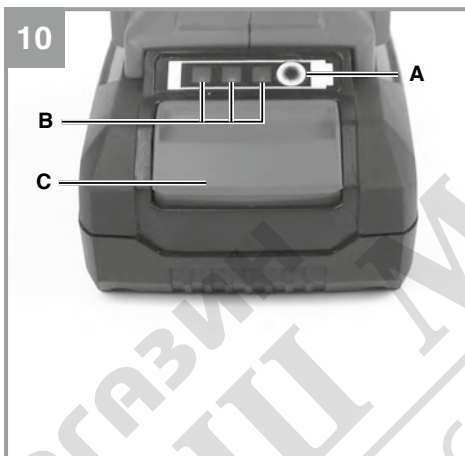
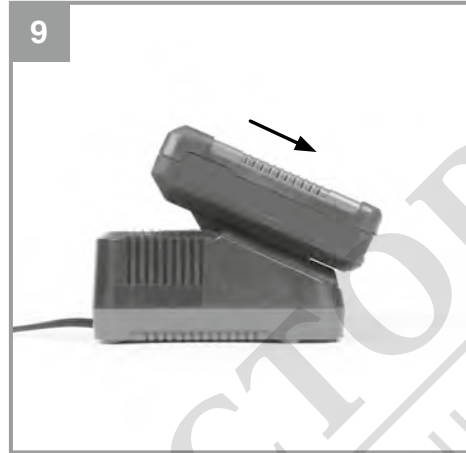
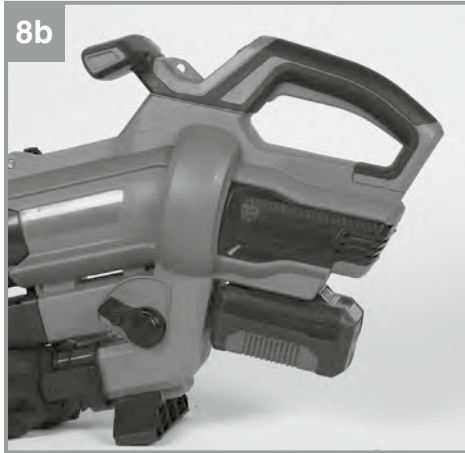

Danger!

When using the equipment, a few safety precautions must be observed to avoid injuries and damage. Please read the complete operating instructions and safety regulations with due care. Keep this manual in a safe place, so that the information is available at all times. If you give the equipment to any other person, hand over these operating instructions and safety regulations as well. We cannot accept any liability for damage or accidents which arise due to a failure to follow these instructions and the safety instructions.

1. Safety regulations

The corresponding safety information can be found in the enclosed booklet.

Warning!

Read all the safety information, instructions, illustrations and technical data provided on or with this power tool. Failure to adhere to the following instructions may result in electric shock, fire and/or serious injury.

Keep all the safety information and instructions in a safe place for future use.

This machine is never allowed to be used by children, persons with reduced physical, sensory or mental capacities or with a lack of experience and knowledge, or persons who are not familiar with the instructions. Local regulations might specify an age limit for the user.

The machine is never allowed to be used when there are people – particularly children – or pets nearby.

Explanation of the warning signs on the equipment (see Fig. 13)

1. Read the directions for use before operating the tool.
2. Keep all other persons away from the danger zone.
3. Do not use the tool in rain or snow. Do not expose the tool to wet conditions.
4. Wear goggles and ear muffs.
5. Rotating parts. Keep your hands and feet away from all openings.
6. Guaranteed sound power level

2. Layout and items supplied**2.1 Layout (Fig. 1/2)**

1. On/Off switch
2. Speed controller
3. Additional handle
4. Star screw M5
5. Harness
6. Rear suction tube
7. Tapping screw
8. Front suction tube
9. Rollers
10. Catch bag
- 10a. Catch bag connection
11. Wall bracket/support
12. Battery mount
13. Blower/Vacuum selector lever

2.2 Items supplied

Please check that the article is complete as specified in the scope of delivery. If parts are missing, please contact our service center or the sales outlet where you made your purchase at the latest within 5 working days after purchasing the product and upon presentation of a valid bill of purchase. Also, refer to the warranty table in the service information at the end of the operating instructions.

- Open the packaging and take out the equipment with care.
- Remove the packaging material and any packaging and/or transportation braces (if available).
- Check to see if all items are supplied.
- Inspect the equipment and accessories for transport damage.
- If possible, please keep the packaging until the end of the guarantee period.

Danger!

The equipment and packaging material are not toys. Do not let children play with plastic bags, foils or small parts. There is a danger of swallowing or suffocating!

- Cordless leaf blower vac
- Original operating instructions
- Safety instructions

3. Proper use

This device is designed to be used for clearing, gathering and picking up dry to slightly damp

leaves and grass from paved areas and lawns. Small, light-weight rubbish such as cigarettes, twigs, paper, etc. can be gathered from asphalted garden paths or lawns by blowing into piles.

Warning:

When the equipment is used in vacuum mode, the material will be shredded by an integrated shredder before it is deposited in the catch bag. Therefore this device is not allowed to be used for picking up hard and heavy foreign bodies (e.g. glass, screws, stones). Do not use the device on unpaved, dry surfaces such as loose gravel and dry garden beds. Do not pick up large quantities of dust. This device is not allowed to be used for picking up liquids or snow. This device is not allowed to be used indoors. This device is not allowed to be used for distributing or picking up chemicals and poisons such as fertilizers, pesticides, materials containing asbestos or inflammable liquids.

The equipment is to be used only for its prescribed purpose. Any other use is deemed to be a case of misuse. The user / operator and not the manufacturer will be liable for any damage or injuries of any kind caused as a result of this.

Please note that our equipment has not been designed for use in commercial, trade or industrial applications. Our warranty will be voided if the machine is used in commercial, trade or industrial businesses or for equivalent purposes.

4. Technical data

Idling speed n°	8000-14000 rpm
Maximum air speed:	210 km/h
Suction power max.:	500 m ³ /h
Blowing power max.:	180 m ³ /h
Volume of catch bag	approx. 45 l
Sound volume level L_{WA}	95.4 dB (A)
Uncertainty K	2.1 dB (A)
Sound pressure level L_{pA}	75.4 dB (A)
Guaranteed sound power level L_{WA} :	98 dB(A)
Vibration a_{hv}	5.64 m/s ²
Uncertainty K	1.5 m/s ²
Weight	3.0 kg

Important!

The equipment is supplied without batteries and without a charger and is allowed to be used only with the lithium-ion batteries of the Power X-Change series!

The lithium-ion batteries of the Power X-Change series are allowed to be charged only with the Power X-charger.

Measured and guaranteed sound power level determined in accordance with 2000/14/EC, extended by 2005/88/EC.

The value given for vibration was determined in accordance with a set of standardized criteria and can be used to compare different products with one another. This value is also suitable to be used for estimating the strain on the user caused by the vibration beforehand.

Caution!

Depending on how you use the device, the actual vibration emissions can vary from the values listed above. Take appropriate measures to protect yourself against vibration stress. Take the entire work sequence into consideration including times at which the device is not working under load or is switched off. Appropriate measures include among other things regular care and maintenance of the device and tool attachments, keeping your hands warm, taking regular breaks and good work sequence planning.

Keep the noise emissions and vibrations to a minimum.

- Only use appliances which are in perfect working order.
- Service and clean the appliance regularly.
- Adapt your working style to suit the appliance.
- Do not overload the appliance.
- Have the appliance serviced whenever necessary.
- Switch the appliance off when it is not in use.
- Wear protective gloves.
- Wear ear-muffs.

Caution!

Residual risks

Even if you use this electric power tool in accordance with instructions, certain residual risks cannot be ruled out. The following hazards may arise in connection with the equipment's construction and layout:

1. Lung damage if no suitable protective dust

- mask is used.
2. Damage to hearing if no suitable ear protection is used.
 3. Health damage caused by hand-arm vibrations if the equipment is used over a prolonged period or is not properly guided and maintained.
 4. Risk of eye damage if suitable safety goggles are not worn.

This equipment generates an electromagnetic field during operation. Under certain circumstances this field may actively or passively impede medical implants. To reduce the risk of serious or fatal injuries, we recommend persons with medical implants to consult their doctor and the manufacturer of the medical implant prior to using the equipment.

5. Before using the equipment

The equipment is supplied without batteries and without a charger.

Warning!

Always remove the batteries before making adjustments to the equipment.

5.1 Preparations

5.1.1 Suction tube

Connect the top suction tube (Fig. 3a/Item 6) and the bottom suction tube (Fig. 3a/Item 8) together. Make sure that the guide lug (Fig. 3a/Item A) is inserted into the corresponding recess (Fig. 3a/Item B) when you do this. Make sure that it latches in place correctly as well.

Screw the two tubes together in addition with the tapping screw (Fig. 3b/Item 7). Now slide the fully assembled suction tube into the motor housing (Fig. 4a) and secure it with the two star screws (Fig. 4b/Item 4).

Important!

Please note that the two suction tubes must always be joined together before they are mounted on the motor housing, and that they must then never be taken apart again. Integrated safety switches will be pressed and the machine supplied with voltage only after the fully assembled suction tube has been properly screwed to the motor housing.

5.2 Fitting the wall bracket

Push the wall bracket (Fig. 5a / Item 11) onto the motor housing (Fig. 5b) as far as the stop. Make sure that the V-shaped cut-out (Fig. 5b / Item 11a) faces the suction tube in order to be able to hang the machine from a screw in the wall. The wall bracket also serves as a support when the machine is placed on the ground.

5.3 Fitting the harness

Pull back the catch (Fig. 6 / Item 5a) of the carabiner and hook it on the motor housing (Fig. 6).

5.4 Fitting / removing the catch bag

- Slip the catch bag connection (Fig. 2 / Item 10a) over the mount (Fig. 7a / Item 10b) on the motor housing. Make sure that it latches in place correctly (Fig. 7b).
- Hook the catch bag on the suction tube in one of the two holes (Fig. 7c / Item 8a/8b) (Fig. 7d). The hole (Fig. 7c / Item 8c) cannot be used on this model.

To remove the catch bag, unhook it from the suction tube. Press the release levers (Fig. 7b / Item 10c) simultaneously on the left and right and pull off the catch bag.

5.5 Fitting the battery

Press the pushlock button (Item C) of the rechargeable battery as shown in Fig. 8a and push the battery into the battery mount provided until it latches in place. Fig. 8b shows the rechargeable batteries when fitted. To remove the battery pack, proceed in reverse order.

5.6 Charging the battery

1. Take the battery pack out of the equipment. To do so, press the pushlock button (Fig. 8a/Item C).
2. Check that your mains voltage is the same as that marked on the rating plate of the battery charger. Insert the power plug of the charger into the socket outlet. The green LED will then begin to flash.
3. Insert the battery pack into the charger (Fig. 9).
4. In the section entitled „Charger indicator“ you will find a table with an explanation of the LED indicator on the charger.

The rechargeable battery can become a little warm during the charging. This is normal.

If the battery pack fails to charge, check:

- whether there is voltage at the socket outlet
- whether there is good contact at the charging contacts

If the battery pack still fails to charge, send

- the charger
 - and the battery pack
- to our customer service center.

To ensure that items are properly packaged and delivered when you send them to us, please contact our customer service or the point of sale at which the equipment was purchased.

When shipping or disposing of batteries and cordless tools, always ensure that they are packed individually in plastic bags to prevent short circuits and fires.

To ensure that the battery pack provides long service, you should take care to recharge it promptly. You must recharge the battery pack when you notice that the performance of the device drops. Never allow the battery pack to become fully discharged. This will cause it to develop a defect.

Battery capacity indicator (Fig. 10)

Press the button for the battery capacity indicator (Item A). The battery capacity indicator (Item B) shows the charge status of the battery using 3 LEDs.

All 3 LEDs are lit:

The battery is fully charged.

2 or 1 LED(s) are lit:

The battery has an adequate remaining charge.

1 LED flashes:

The battery is empty, recharge the battery.

All LEDs blink:

The battery temperature is too low. Remove the battery from the equipment, keep it at room temperature for one day. If the fault reoccurs, this means that the rechargeable battery has undergone exhaustive discharge and is defective. Remove the battery from the equipment. Never use or charge a defective battery.

6. Operation

Danger!

Start up the equipment only when fully assembled.

6.1 Sizing the strap

Slip the harness over your shoulder and adjust the length of the harness so that you can handle the equipment comfortably.

Caution: Wear the harness in such a way that the snap fastener is always close to hand. In an emergency you can always remove the equipment quickly by opening the snap fastener (Fig. 11 / Item 5a).

6.2 Switching the machine On/Off (Fig. 12)

- To switch on, press the On/Off switch (Item 1).
- To switch off, let go of the On/Off switch.

6.3 Speed control

The equipment is fitted with a variable speed trigger. To use it, turn the speed controller (Fig. 12 / Item 2) to the desired position. Use the device only with the speed which is actually required and do not let it run at a speed which is faster than necessary.

MIN = Minimum speed

MAX = Maximum speed

6.4 Mode of operation

Caution! Search the surface for concealed objects (e.g. small animals or hard foreign bodies) before starting to use the equipment.

6.4.1 Blowing foliage

Caution!

If you point the air flow towards other people, animals or objects (e.g. windows), this could cause injuries and damage.

- Point the air flow away from yourself.
- Never point the air flow towards other people, animals or objects.
- Do not blow away any hard objects such as stones or twigs.
- Turn the selector lever (Fig. 12 / Item 13) into the position shown. You can do this regardless of whether the tool is running or not.
- Channel the air stream forward and walk slowly to blow foliage or garden refuse into a pile or to clear out hard-to-reach places.

Danger!

Never gather (blow) hot, combustible or explosive materials into piles.

6.4.2 Sucking up foliage**Caution!**

- Only use the leaf blower vac in vacuum mode if the catch bag is undamaged and properly fitted.
- Do not pick up too many leaves in one go as this could clog the tube and the shredder.
- To clear any blockages, follow the steps described in the section "Clearing blockages".
- Do not pick up hard or damp materials.
- Turn the selector lever (Fig. 12 / Item 13) to position "B". You can do this regardless of whether the tool is running or not.
- Always position the suction tube on the ground and adjust the length of the strap to your requirements (see section 6.1). The guide rollers (Fig. 1/Item 9) at the bottom end of the suction tube will help you to maneuver the suction tube on the ground.
- Turn on the equipment (see section 6.2).
- Set the desired suction power with the speed controller (see section 6.5).

6.5 Emptying the catch bag

Empty the catch bag (Fig. 1/Item 10) in good time. With a nearly full bag, the suction power drops notably. Organic waste should be composted.

- Switch off the equipment and remove the batteries.
- Open the zipper on the catch bag (Fig. 1/Item 10) and shake out the material.
- Close the zip on the catch bag (Fig. 1/Item 10) again.

6.6 Clearing blockages**Danger!**

- Switch off the equipment, wait for the moving parts to come to a standstill and remove the batteries.
- Wear protective gloves
- Use suitable tools (e.g. a wooden stick)

1. Examine the tube for blockages. Tap the suction tube carefully or use a wooden stick to clear any blockages.
2. Empty the catch bag and remove it. Dismantle the suction tube (remove the star screws, see Fig. 4b / Item 4).
3. Examine the openings in the motor housing for possible blockages. Remove the blockage with a stick if necessary. Make sure that the

shredder is clear.

7. Cleaning, maintenance and ordering spare parts**Hazard!**

Always remove the batteries before starting any cleaning work.

7.1 Cleaning

- Keep all safety devices, air vents and the motor housing free of dirt and dust as far as possible. Wipe the equipment with a clean cloth or blow it with compressed air at low pressure.
- We recommend that you clean the device immediately each time you have finished using it.
- Clean the equipment regularly with a moist cloth and some soft soap. Do not use cleaning agents or solvents; these could attack the plastic parts of the equipment. Ensure that no water can seep into the device. The ingress of water into an electric tool increases the risk of an electric shock.
- After shaking out the catch bag, turn it inside out and thoroughly clean it in order to prevent mold and unpleasant odors from forming.
- You can use soap and water to clean out a heavily soiled catch bag.
- Rub a bar of dry soap across the zipper teeth if the zipper becomes difficult to pull.
- Clean the vacuum/blower tube with a brush upon evidence of dirt and grime.
- Dirt from the vacuumed material can make it more difficult to move the selector lever (blower/vacuum). To restore smooth operation of the selector lever, simply flip the lever back and forth several times from vacuum to blower.

7.2 Maintenance

- Should the equipment experience problems beyond those mentioned above, let only an authorized professional or a customer service shop perform an inspection.
- There are no other parts inside the equipment which require maintenance.

7.3 Ordering replacement parts:

Please quote the following data when ordering replacement parts:

- Type of machine
- Article number of the machine
- Identification number of the machine
- Replacement part number of the part required

For our latest prices and information please go to www.Einhell-Service.com

8. Faults

The equipment does not work:

Important!

All connections must be tightly secured.

Check that the battery is charged and whether the charging unit is working. If the equipment will not work in spite of the voltage supply being OK, please send it to the customer service address below.

9. Disposal and recycling

The equipment is supplied in packaging to prevent it from being damaged in transit. The raw materials in this packaging can be reused or recycled. The equipment and its accessories are made of various types of material, such as metal and plastic. Never place defective equipment in your household refuse. The equipment should be taken to a suitable collection center for proper disposal. If you do not know the whereabouts of such a collection point, you should ask in your local council offices.

10. Storage

Store the equipment and accessories in a dark and dry place at above freezing temperature. The ideal storage temperature is between 5 and 30 °C. Store the electric tool in its original packaging.

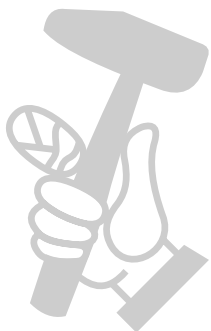

11. Charger indicator

Indicator status		Explanations and actions
Red LED	Green LED	
Off	Flashing	<p>Ready for use The charger is connected to the mains and is ready for use; there is no battery pack in the charger</p>
On	Off	<p>Charging The charger is charging the battery pack in quick charge mode. The charging times are shown directly on the charger. Important! The actual charging times may vary slightly from the stated charging times depending on the existing battery charge.</p>
Off	On	<p>The battery is charged and ready for use. The unit then changes over to gentle charging mode until the battery is fully charged. To do this, leave the rechargeable battery on the charger for approx. 15 minutes longer. Action: Take the battery pack out of the charger. Disconnect the charger from the mains supply.</p>
Flashing	Off	<p>Adapted charging The charger is in gentle charging mode. For safety reasons the charging is performed less quickly and takes more time. The reasons can be: - The rechargeable battery has not been used for a very long time. - The battery temperature is outside the ideal range. Action: Wait for the charging to be completed; you can still continue to charge the battery pack.</p>
Flashing	Flashing	<p>Fault Charging is no longer possible. The battery pack is defective. Action: Never charge a defective battery pack. Take the battery pack out of the charger.</p>
On	On	<p>Temperature fault The battery pack is too hot (e.g. due to direct sunshine) or too cold (below 0° C). Action: Remove the battery pack and keep it at room temperature (approx. 20° C) for one day .</p>



For EU countries only

Never place any electric power tools in your household refuse.

To comply with European Directive 2012/19/EC concerning old electric and electronic equipment and its implementation in national laws, old electric power tools have to be separated from other waste and disposed of in an environment-friendly fashion, e.g. by taking to a recycling depot.

Recycling alternative to the return request:

As an alternative to returning the equipment to the manufacturer, the owner of the electrical equipment must make sure that the equipment is properly disposed of if he no longer wants to keep the equipment. The old equipment can be returned to a suitable collection point that will dispose of the equipment in accordance with the national recycling and waste disposal regulations. This does not apply to any accessories or aids without electrical components supplied with the old equipment.

The reprinting or reproduction by any other means, in whole or in part, of documentation and papers accompanying products is permitted only with the express consent of the Einhell Germany AG.

Subject to technical changes

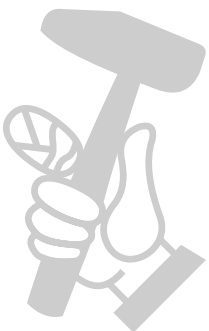

Service information

We have competent service partners in all countries named on the guarantee certificate whose contact details can also be found on the guarantee certificate. These partners will help you with all service requests such as repairs, spare and wearing part orders or the purchase of consumables.

Please note that the following parts of this product are subject to normal or natural wear and that the following parts are therefore also required for use as consumables.

Category	Example
Wear parts*	Battery
Consumables*	
Missing parts	

* Not necessarily included in the scope of delivery!

In the effect of defects or faults, please register the problem on the internet at www.Einhell-Service.com. Please ensure that you provide a precise description of the problem and answer the following questions in all cases:

- Did the equipment work at all or was it defective from the beginning?
- Did you notice anything (symptom or defect) prior to the failure?
- What malfunction does the equipment have in your opinion (main symptom)? Describe this malfunction.

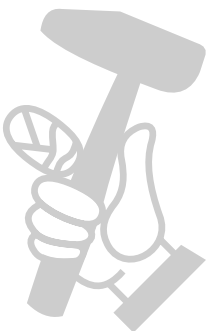

Warranty certificate

Dear Customer,

All of our products undergo strict quality checks to ensure that they reach you in perfect condition. In the unlikely event that your device develops a fault, please contact our service department at the address shown on this guarantee card. You can also contact us by telephone using the service number shown. Please note the following terms under which guarantee claims can be made:

1. These guarantee terms apply to consumers only, i.e. natural persons intending to use this product neither for their commercial activities nor for any other self-employed activities. These warranty terms regulate additional warranty services, which the manufacturer mentioned below promises to buyers of its new products in addition to their statutory rights of guarantee. Your statutory guarantee claims are not affected by this guarantee. Our guarantee is free of charge to you.
2. The warranty services cover only defects due to material or manufacturing faults on a product which you have bought from the manufacturer mentioned below and are limited to either the rectification of said defects on the product or the replacement of the product, whichever we prefer.
Please note that our devices are not designed for use in commercial, trade or professional applications. A guarantee contract will not be created if the device has been used by commercial, trade or industrial business or has been exposed to similar stresses during the guarantee period.
3. The following are not covered by our guarantee:
 - Damage to the device caused by a failure to follow the assembly instructions or due to incorrect installation, a failure to follow the operating instructions (for example connecting it to an incorrect mains voltage or current type) or a failure to follow the maintenance and safety instructions or by exposing the device to abnormal environmental conditions or by lack of care and maintenance.
 - Damage to the device caused by abuse or incorrect use (for example overloading the device or the use of unapproved tools or accessories), ingress of foreign bodies into the device (such as sand, stones or dust, transport damage), the use of force or damage caused by external forces (for example by dropping it).
 - Damage to the device or parts of the device caused by normal or natural wear or tear or by normal use of the device.
4. The guarantee is valid for a period of 24 months starting from the purchase date of the device. Guarantee claims should be submitted before the end of the guarantee period within two weeks of the defect being noticed. No guarantee claims will be accepted after the end of the guarantee period. The original guarantee period remains applicable to the device even if repairs are carried out or parts are replaced. In such cases, the work performed or parts fitted will not result in an extension of the guarantee period, and no new guarantee will become active for the work performed or parts fitted. This also applies if an on-site service is used.
5. To make a claim under the guarantee, please register the defective device at: www.Einhell-Service.com. Please keep your bill of purchase or other proof of purchase for the new device. Devices that are returned without proof of purchase or without a rating plate shall not be covered by the guarantee, because appropriate identification will not be possible. If the defect is covered by our guarantee, then the item in question will either be repaired immediately and returned to you or we will send you a new replacement.

Of course, we are also happy offer a chargeable repair service for any defects which are not covered by the scope of this guarantee or for units which are no longer covered. To take advantage of this service, please send the device to our service address.

Also refer to the restrictions of this warranty concerning wear parts, consumables and missing parts as set out in the service information in these operating instructions.

