

Einhell

CE-JS 12/1



| | | | |
|----------|--|-----|---|
| D | Originalbetriebsanleitung Fremdstarter – Energiestation | FIN | Alkuperäiskäyttöohje Apukäynnistin / Varavirtalähde |
| GB | Original operating instructions Jump Start – Power Bank | RUS | Оригинальное руководство по эксплуатации Внешний аккумулятор – Узел электропитания |
| F | Instructions d'origine Démarreur externe – station d'énergie | SLO | Originalna navodila za uporabo Zunanji zaganjač – Energetska postaja |
| I | Istruzioni per l'uso originali Avviatore di emergenza – Carica- batterie portatile | RO | Instrucțiuni de utilizare originale Starter auto – Stație de energie |
| DK/ N | Original betjeningsvejledning Jumpstarter – Energiestation | GR | Πρωτότυπες Οδηγίες χρήσης Βοηθητική εξωτερική εκκίνηση - μονάδα ενέργειας |
| S | Original-bruksanvisning Starthjälp – Energiestation | | |
| NL | Originele handleiding Externe starter – energiestation | | |
| E | Manual de instrucciones original Arrancador de batería - unidad energética | | |



Art.-Nr.: 10.915.21

I.-Nr.: 21020

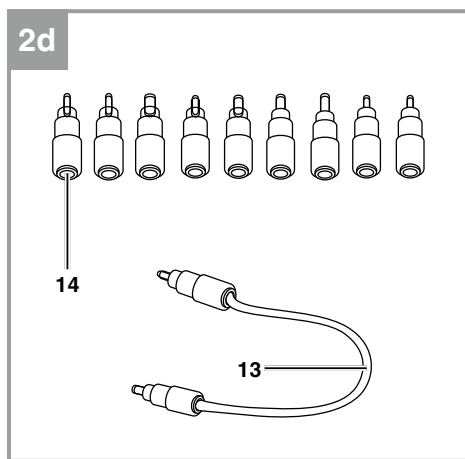
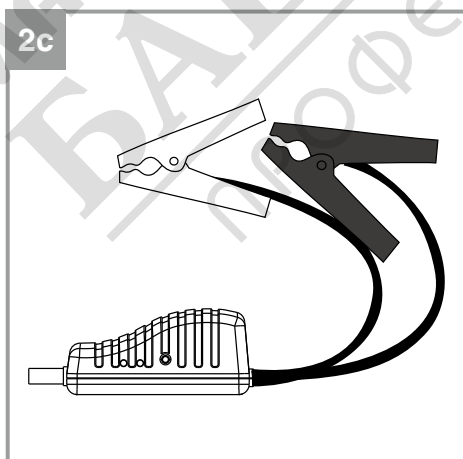
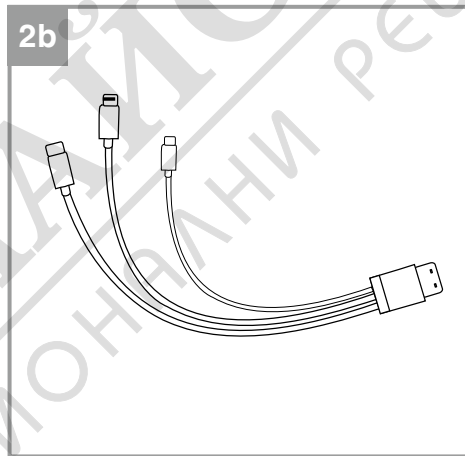
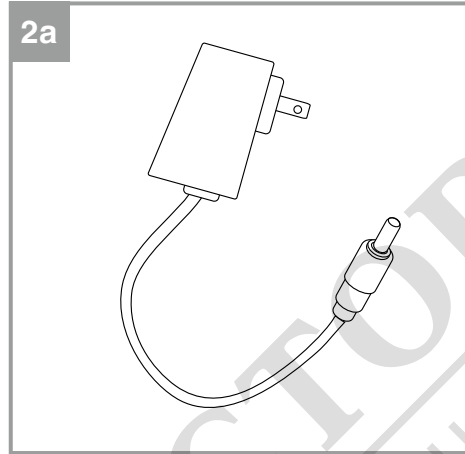
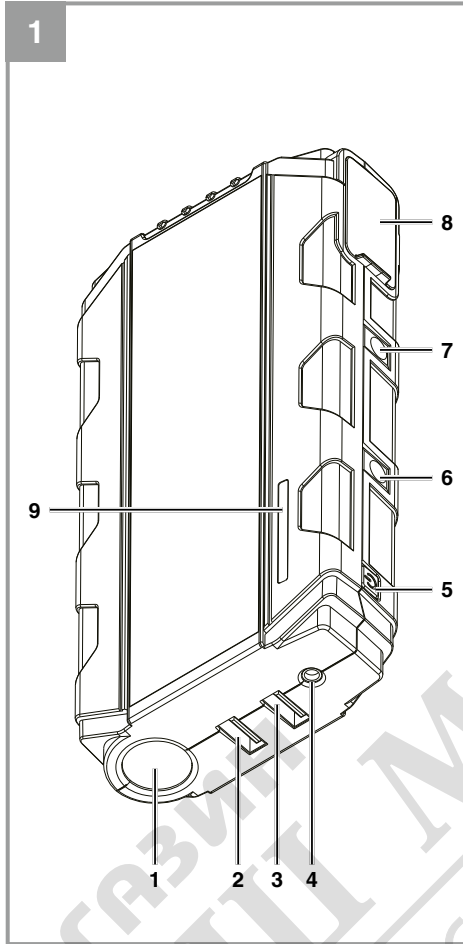

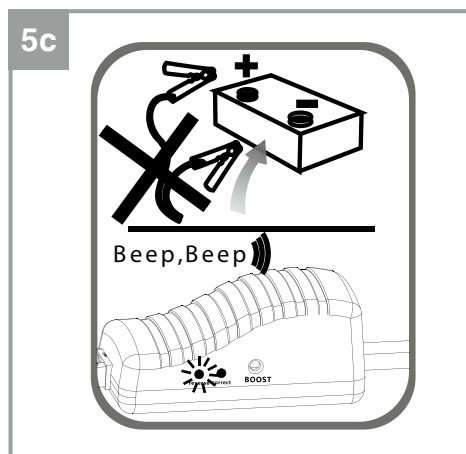
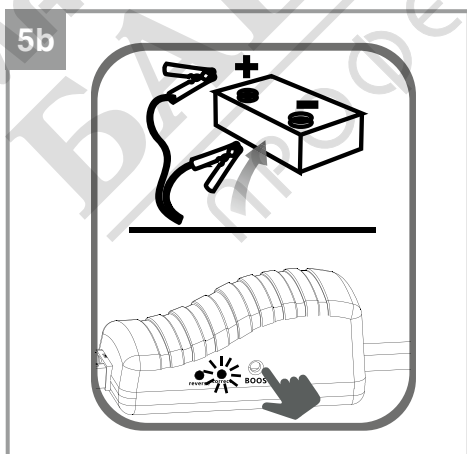
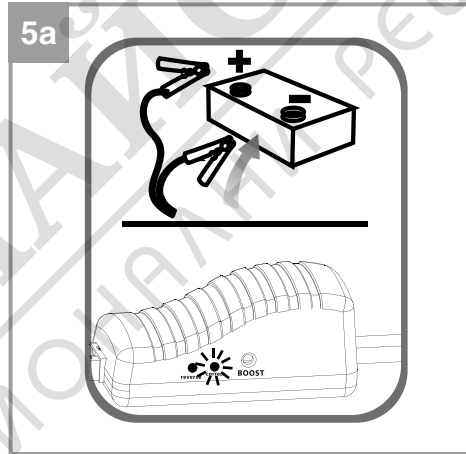
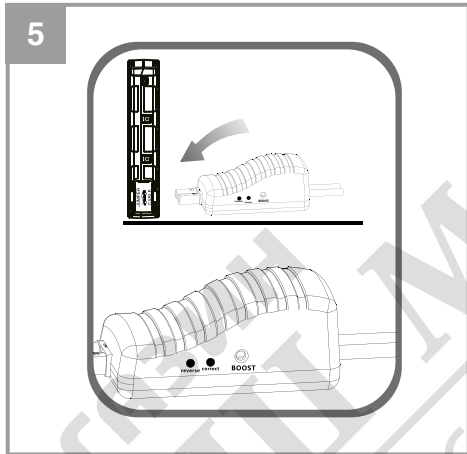
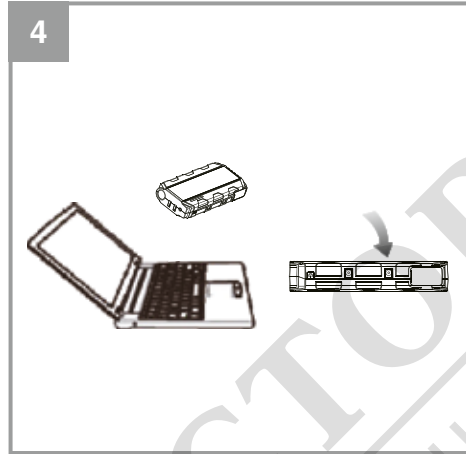
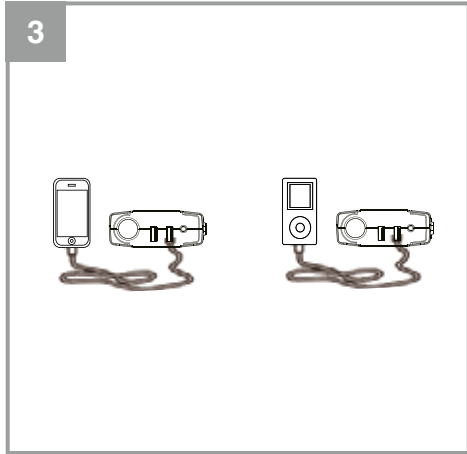

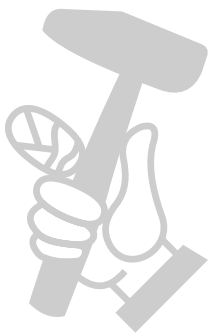
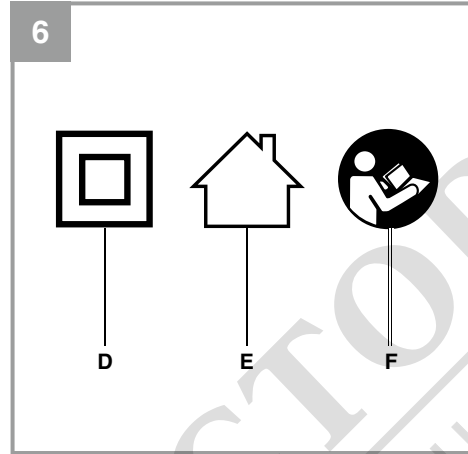
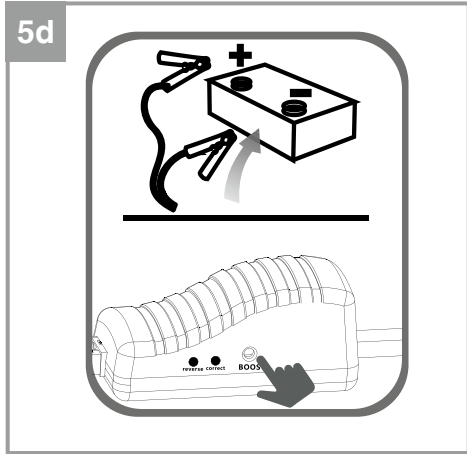

МАГАЗИН МАЙСТОРА
БАШ МАЙСТОРА
ПРОФЕСИОНАЛНИ РЕШЕНИЯ

Danger!

When using the equipment, a few safety precautions must be observed to avoid injuries and damage. Please read the complete operating instructions and safety regulations with due care. Keep this manual in a safe place, so that the information is available at all times. If you give the equipment to any other person, hand over these operating instructions and safety regulations as well. We cannot accept any liability for damage or accidents which arise due to a failure to follow these instructions and the safety instructions.

1. Safety regulations

The corresponding safety information can be found in the enclosed booklet.

Danger!

Read all safety regulations and instructions.

Any errors made in following the safety regulations and instructions may result in an electric shock, fire and/or serious injury.

Keep all safety regulations and instructions in a safe place for future use.

Children are not allowed to use this equipment. Children should be supervised so that they do not play with the equipment. Children are not allowed to carry out cleaning or maintenance. This equipment is not allowed to be used by people with limited physical, sensory or mental capacities or by those with insufficient knowledge or experience unless they are supervised or instructed by a person who is responsible for them.

Key (Fig. 6)

D = Protection class II for the equipment

E = For use in dry indoor areas only

F = Important! Read carefully before use!

Text on the equipment and jump start cable

Important! Read carefully before use!

1. Never press the "Boost" button before the car battery has been connected.
2. Never connect the clamps together – risk of a short-circuit and risk of injury.
3. Jump start only for 12 V cars; connect the red clamp to the "+" and the black clamp to the "-" battery pole.
4. „Correct“ LED lights up green = Start the engine within 30 seconds.
5. Red LED + acoustic warning signal = Battery connected reverse polarity (see 3.)

6. „Correct“ LED flashes green = Press the „Boost“ button and start the engine within 30 seconds.
7. No LED, no acoustic warning signal = Check the connector to the equipment, press the „Boost“ button and start the engine within 30 seconds.

Warning!

1. Keep the equipment out of reach of children!
2. Do not open the equipment - risk of injury!
3. If fewer than 3 LEDs are illuminated, the jump start is not available.
4. If the engine fails to start within 5 seconds, stop the jump start operation. Wait at least 1 minute before you repeat the operation.

2. Layout and items supplied**2.1 Layout (Fig. 1)**

1. LED light
2. 5V max. 2A USB outlet
3. 5V/9V USB outlet
4. 15V d.c. /1A charging jack
5. On/Off button
6. 12V max. 10 A d.c. voltage outlet
7. 19V max. 3.5 A d.c. voltage outlet
8. Connection for jump start cable
9. LED battery capacity indicator

2.2 Items supplied

Please check that the article is complete as specified in the scope of delivery. If parts are missing, please contact our service center or the sales outlet where you made your purchase at the latest within 5 working days after purchasing the product and upon presentation of a valid bill of purchase. Also, refer to the warranty table in the service information at the end of the operating instructions.

- Open the packaging and take out the equipment with care.
- Remove the packaging material and any packaging and/or transportation braces (if available).
- Check to see if all items are supplied.
- Inspect the equipment and accessories for transport damage.
- If possible, please keep the packaging until the end of the guarantee period.

Danger!

The equipment and packaging material are not toys. Do not let children play with plastic bags, foils or small parts. There is a danger of swallowing or suffocating!

- Jump start power bank
- Jump start cable
- 3-in-1 USB connection cable (Micro/Mini/C)
- Charger
- 19V connection cable
- 19V set of connectors
- Storage case
- Original operating instructions
- Safety instructions

3. Proper use

The jump start power bank is designed for charging smart phones, cameras, tablets, etc. It can also be used as a torch light. In addition, notebooks and 12 V consumers can be supplied with DC voltage. Used with the supplied jump start cable the equipment can also be used as a support for 12 V starter batteries (lead acid batteries) in motor vehicles with maximum petrol engine capacities of 4000 ccm and diesel engines with capacities of up to 2000 ccm.

The equipment is to be used only for its prescribed purpose. Any other use is deemed to be a case of misuse. The user / operator and not the manufacturer will be liable for any damage or injuries of any kind caused as a result of this.

Please note that our equipment has not been designed for use in commercial, trade or industrial applications. Our warranty will be voided if the machine is used in commercial, trade or industrial businesses or for equivalent purposes.

4. Technical data**Jump start power bank**

Li-Po battery: 11.1 V – 3700 mAh – 41.1 Wh
 Input: 15 V d.c./1 A
 Charging time, approx.: 5 h
 USB outlet "OUT: "5V/2A": 5 V d.c. / 2 A (max.)
 USB outlet "OUT: "5V/9V":
 5 V d.c./3 A (max.)
 9 V d.c./2 A (max.)
 d.c. voltage outlet: 19 V max. 3.5 A
 d.c. voltage outlet: 12 V max. 10 A
 Jump starting
 current: 200 A (5 sec) / 400 A (max.)
 Ambient temperature
 for jump starting: + 15 °C - + 40 °C
 Storage temperature: + 5 °C - + 40 °C
 Protection class: III

Charger

Nominal input voltage: 100-240 V ~50/60 Hz
 Nominal output voltage: 15 V DC
 Nominal output current: 1 A

5. Before starting the equipment**5.1 Charging the jump start power bank with the charger supplied****The following applies to the charger:**

This equipment can be used by children of 8 years and older and by people with limited physical, sensory or mental capacities or those with no experience and knowledge if they are supervised or have received instruction in how to use the equipment safely and understand the dangers which result from such use. Children are not allowed to play with the equipment. Unless supervised, children are not allowed to clean the equipment or carry out user-level maintenance work.

Before you connect the equipment to the power supply make sure that the data on the rating plate are identical to the supply voltage.

Important! Pull out the power plug before making adjustments to the equipment. Charge the equipment only with the charger supplied.

Observe the enclosed safety information with detailed information about charging.

The outlets must not be used while charging is in progress.

- Connect the supplied charger (Fig. 2a) to the „15 V 1A input“ charging jack (Fig. 1 / Item 4) on the equipment.
- Plug the charger into the socket outlet and the battery will be charged. The LED (Fig. 1 / Item 9) shine (flash) during charging and indicate the charging status. When charging is finished, all the LEDs shine.
- The time it takes to fully recharge an empty battery is approximately 5 hours. The temperature of the battery pack may rise slightly during the charging operation. This is normal.

5.2 Battery capacity indicator

Press the ON/OFF button (Fig. 1/Item 5) briefly. The LED for the battery capacity indicator (Fig. 1 / Item 9) light up. The number of LEDs that are lit indicate the current charge level of the integrated Li-Po battery.

100% charged = 4 LED steady on
>25% charged = 1 LED steady on
<25% charged = no LED steady on

5.3 Time limits

To protect the integrated battery cells, the LED light will switch off after being in use for approx. 4 hours.

6. LED lamp

Caution! Do not look into the light beam.

- Press the ON/OFF button for 3 seconds – the LED lamp (Fig. 1 / Item 1) will be permanently lit.
- Press the ON/OFF button again – the LED lamp will be lit as a „strobe light“.
- Press the ON/OFF button again – the LED lamp will be lit as an „SOS“ Morse code signal lamp.
- Press the button again to switch the LED lamp off again.

7. Outputs

Caution! Check the voltage and current ratings of the device you want to connect (e.g. mobile phone, notebook). Observe the operating instructions for the device.

The supply time varies according to the level of the charge of the jump start power bank, the level of power consumption and the intensity of use of the connected device. The battery needs charging when the remaining charge is 25% (1 LED shines) (see section 5). If the input current of the connected device is very low, the equipment will switch off again within a few seconds. The equipment will also switch off if the integrated battery is empty.

The USB ports can be used in parallel. Please ensure that the cumulative output current does not exceed 5 A.

7.1 Charging/operating devices with a USB connection

a) 5V/2A USB outlet

1. Connect an available (or the supplied 3-in-1) USB connection cable to the USB port (Fig. 1 / Item 2) on the jump start power bank and then to the device you want to connect (max. 2A).
2. Press the ON/OFF button (Fig. 1 / Item 5).

b) “OUT 5V/9V” USB outlet (Fig. 3)

Note: If charging does not work with this outlet, this means that either the device or the cable is not supported. In this case, use the 5V d.c. / 2A USB outlet for charging, as described above.

1. Connect the supplied 3-in-1 USB cable (Fig. 2b) to the “OUT 5V/9V” USB port (Fig. 1 / Item 3) on the jump start power bank and then to the device you want to connect.
2. Press the ON/OFF button (Fig. 1 / Item 5).
3. The parameters required for charging will be determined at the USB outlet and the connected device will be charged up. Depending on the charger cable and the device being charged, the charging time with the “OUT 5V/9V” USB outlet may be shorter than with the “OUT 5V/2A” USB outlet.

7.2 Operating 19 V d.c. Devices (Fig. 4)

1. Connect the supplied connection cable (Fig. 2d / Item 13) to the 19 V d.c. outlet (Fig. 1 / Item 7) on the jump start power bank and then to the 19 V d.c. device, using the supplied connector (Fig. 2d / Item 14) if necessary. The maximum power consumption must not exceed 3.5A.
2. Press the ON/OFF button (Fig. 1/Item 5).

7.3 Operating 12 V d.c. devices

1. Connect a suitable connection cable to the 12

V d.c. outlet (Fig. 1 / Item 6) on the jump start power bank and then to the 12 V d.c. device. The maximum power consumption must not exceed 10 A.

2. Press the ON/OFF button (Fig. 1/Item 5).

8. Jump starting for the vehicle

The 12 V jump starting function provides welcome help with starting difficulties due to too little battery capacity.

Warning! Only the jump start cable is allowed to be connected during jump starting. Any power supply to a connected device, e.g. via the USB port, must be disconnected first.

- Consult the vehicle's operating manual for information about jump starting. Non-observance can lead to damage to the vehicle.
- Switch off all power consumers on the vehicle (headlights, radio, ...). Never try to start a vehicle without a connected starter battery.
- Make sure that the connector on the jump start cable is securely connected to the device socket. If the connection is loose during jump starting, the connector could melt as a result of the high current.
- The poles on the vehicle battery must be clean and the clamps of the jump start cable must be securely attached to the battery poles.
- **Warning!** Do not connect together the clamps of the jump start cable when the "Boost" button is pressed or while jump starting is in progress – this will lead to short-circuiting with sparking, to risk of explosion and to the destruction of the equipment..

Check that at least 3 LED of the battery capacity indicator are lit. The equipment temperature must be within the range of + 5 °C - + 40°C and the ambient temperature during jump starting within the range of - 15°C - + 40°C. Use only the supplied jump start cable (Fig. 2c).

1. Fig. 5: Pull open the cover on the jump start cable connection (Fig. 1 / Item 8), push the cover underneath it to the side and plug the jump start cable into the equipment.
2. Fig. 5a: Connect the red cable to the positive pole on the car's battery and the black cable to the negative pole on the car's battery. Make sure that the clamps are secure. In addition,

make sure that the jump start power bank is tucked away securely in the engine bay and will not be able to fall as a result of vibrations during the jump start operation. The jump start power bank must not be allowed to come within the range of moving parts. The following points 3. – 6. describe the status signals of the jump start cable. Please follow the instructions.

3. Fig. 5a: **The "Correct" LED on the jump start cable lights up green.** All the existing connections are OK and the vehicle can be started within 30 seconds.
4. Fig. 5b: **The "Correct" LED on the jump start cable flashes green.** All the existing connections are OK, but the car battery charge status is very low. Press the "Boost" button on the jump start cable and wait until the "Correct" LED lights up green continuously. Start the vehicle within 30 seconds. Be particularly careful because pressing the "Boost" button has the effect of overriding the safety devices integrated in the jump start power bank
5. Fig. 5c: **The red LED on the jump start cable lights up and an acoustic warning signal sounds.** The clamps of the jump start cable are wrongly connected to the car battery, i.e. with reverse polarity. Remove the clamps and connect them to the car battery again but with the correct polarity and in accordance with the previous instructions.
6. Fig. 5d: **No LED lights up on the jump start cable, nor is there an acoustic warning signal.** Check all the connections, especially that the clamps are connected to the car battery with the correct polarity. If all the connections are OK, the cause is probably a defective car battery. Press the "Boost" button on the jump start cable and wait until the "Correct" LED lights up green continuously. Start the vehicle within 30 seconds. Be particularly careful, because pressing the "Boost" button has the effect of overriding the safety devices integrated in the jump start power bank. Replace the defective car battery as soon as possible.
7. As soon as the engine is running, remove the jump start cable from the equipment and then remove the red clamp from the car battery first, followed by the black clamp.
8. Let the engine run. The generator will charge up the built-in car battery.

At very low temperatures a number of jump start attempts may be required before the car starts up. Allow one minute waiting time between each attempt. Remove the equipment within 30 seconds after a successful jump start as far as possible.

The number of times that you can attempt to start the engine (max. 4 within 10 minutes) varies according to the ambient temperature, the condition of the battery you want to start and the charge level of the jump start power bank battery.

If too many attempts to start are carried out within 10 minutes, the "Correct" LED will flash green / red in alternation and further attempts to start will be blocked. The jump start function will become available again after a 10-minute waiting period provided the battery has enough capacity and the integrated safety device is compliant.

9. Cleaning, maintenance and ordering of spare parts

Danger!

Always pull out the power plug before starting any cleaning work.

Remove all the connected cables from the jump start power bank.

9.1 Cleaning

- Keep all safety devices, air vents and the motor housing free of dirt and dust as far as possible. Wipe the equipment with a clean cloth or blow it with compressed air at low pressure.
- We recommend that you clean the device immediately each time you have finished using it.
- Clean the equipment regularly with a damp cloth. Do not use cleaning agents or solvents; these could attack the plastic parts of the equipment. Ensure that no water can seep into the device. The ingress of water into an electric tool increases the risk of an electric shock.

9.2 Maintenance

There are no parts inside the equipment which require additional maintenance.

9.3 Ordering replacement parts:

Please quote the following data when ordering replacement parts:

- Type of machine
- Article number of the machine
- Identification number of the machine
- Replacement part number of the part required

For our latest prices and information please go to www.Einhell-Service.com

10. Repair

Should the tool experience problems beyond those mentioned above, let only an authorised professional or a customer service shop perform an inspection.

11. Disposal and recycling

The equipment is supplied in packaging to prevent it from being damaged in transit. The raw materials in this packaging can be reused or recycled. The equipment and its accessories are made of various types of material, such as metal and plastic. Never place defective equipment in your household refuse. The equipment should be taken to a suitable collection center for proper disposal. If you do not know the whereabouts of such a collection point, you should ask in your local council offices.

12. Storage

Store the equipment and its accessories in a dark and dry place at above freezing temperature. The ideal storage temperature is between +5 and 40°C.

Observe the enclosed safety information with detailed information about storage. Since the battery reacts if the temperature is too high (above +40°C) or too low (below 0°C), do not keep the battery permanently in a vehicle. For transporting in a vehicle, place the equipment in a suitable location where it cannot move in response to an abrupt change in speed and/or direction. Keep the equipment in its original packaging.

13. Troubleshooting guide

| Fault | Possible cause | Remedy |
|--------------------------------------|--|--|
| The equipment cannot be switched on: | - Battery voltage too low | - Charge battery |
| Jump starting does not work | - Battery voltage too low - Connections on the vehicle connected with reverse polarity - Temperature outside the temperature range | - Charge battery - Check the polarity and connect correctly - Try jump starting within the temperature range |
| All LED flash | - The overload cutout has responded - Equipment too cold/hot - Ambient temperature too low/high | - Switch off the equipment, check for possible overloading - Observe equipment temperature of + 5°C - + 40°C. - Observe ambient temperature range of - 15°C - + 40°C |

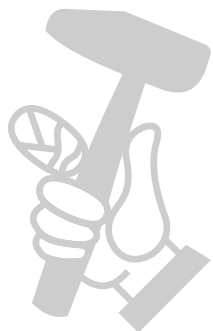



For EU countries only

Never place any electric power tools in your household refuse.

To comply with European Directive 2012/19/EC concerning old electric and electronic equipment and its implementation in national laws, old electric power tools have to be separated from other waste and disposed of in an environment-friendly fashion, e.g. by taking to a recycling depot.

Recycling alternative to the return request:

As an alternative to returning the equipment to the manufacturer, the owner of the electrical equipment must make sure that the equipment is properly disposed of if he no longer wants to keep the equipment. The old equipment can be returned to a suitable collection point that will dispose of the equipment in accordance with the national recycling and waste disposal regulations. This does not apply to any accessories or aids without electrical components supplied with the old equipment.

This consignment contains lithium-ion batteries.

In accordance with special provision 188 this consignment is not subject to the ADR regulations. Handle with care. Danger of ignition in case of damage to the consignment package. If the consignment package is damaged: Check and if necessary repackage.

For further information contact: 0049 9951 95920-66. Outside Germany charges will apply instead for a regular call to a landline number in Germany.

The reprinting or reproduction by any other means, in whole or in part, of documentation and papers accompanying products is permitted only with the express consent of the Einhell Germany AG.

Subject to technical changes



Service information

We have competent service partners in all countries named on the guarantee certificate whose contact details can also be found on the guarantee certificate. These partners will help you with all service requests such as repairs, spare and wearing part orders or the purchase of consumables.

Please note that the following parts of this product are subject to normal or natural wear and that the following parts are therefore also required for use as consumables.

| Category | Example |
|---------------|---------|
| Wear parts* | Battery |
| Consumables* | |
| Missing parts | |

* Not necessarily included in the scope of delivery!

In the effect of defects or faults, please register the problem on the internet at www.Einhell-Service.com. Please ensure that you provide a precise description of the problem and answer the following questions in all cases:

- Did the equipment work at all or was it defective from the beginning?
- Did you notice anything (symptom or defect) prior to the failure?
- What malfunction does the equipment have in your opinion (main symptom)? Describe this malfunction.

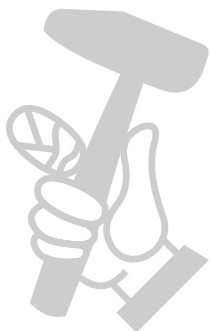

Warranty certificate

Dear Customer,

All of our products undergo strict quality checks to ensure that they reach you in perfect condition. In the unlikely event that your device develops a fault, please contact our service department at the address shown on this guarantee card. You can also contact us by telephone using the service number shown.

Please note the following terms under which guarantee claims can be made:

1. These guarantee terms apply to consumers only, i.e. natural persons intending to use this product neither for their commercial activities nor for any other self-employed activities. These warranty terms regulate additional warranty services, which the manufacturer mentioned below promises to buyers of its new products in addition to their statutory rights of guarantee. Your statutory guarantee claims are not affected by this guarantee. Our guarantee is free of charge to you.
2. The warranty services cover only defects due to material or manufacturing faults on a product which you have bought from the manufacturer mentioned below and are limited to either the rectification of said defects on the product or the replacement of the product, whichever we prefer.
Please note that our devices are not designed for use in commercial, trade or professional applications. A guarantee contract will not be created if the device has been used by commercial, trade or industrial business or has been exposed to similar stresses during the guarantee period.
3. The following are not covered by our guarantee:
 - Damage to the device caused by a failure to follow the assembly instructions or due to incorrect installation, a failure to follow the operating instructions (for example connecting it to an incorrect mains voltage or current type) or a failure to follow the maintenance and safety instructions or by exposing the device to abnormal environmental conditions or by lack of care and maintenance.
 - Damage to the device caused by abuse or incorrect use (for example overloading the device or the use of unapproved tools or accessories), ingress of foreign bodies into the device (such as sand, stones or dust, transport damage), the use of force or damage caused by external forces (for example by dropping it).
 - Damage to the device or parts of the device caused by normal or natural wear or tear or by normal use of the device.
4. The guarantee is valid for a period of 24 months starting from the purchase date of the device. Guarantee claims should be submitted before the end of the guarantee period within two weeks of the defect being noticed. No guarantee claims will be accepted after the end of the guarantee period. The original guarantee period remains applicable to the device even if repairs are carried out or parts are replaced. In such cases, the work performed or parts fitted will not result in an extension of the guarantee period, and no new guarantee will become active for the work performed or parts fitted. This also applies if an on-site service is used.
5. To make a claim under the guarantee, please register the defective device at: www.Einhell-Service.com. Please keep your bill of purchase or other proof of purchase for the new device. Devices that are returned without proof of purchase or without a rating plate shall not be covered by the guarantee, because appropriate identification will not be possible. If the defect is covered by our guarantee, then the item in question will either be repaired immediately and returned to you or we will send you a new replacement.

Of course, we are also happy offer a chargeable repair service for any defects which are not covered by the scope of this guarantee or for units which are no longer covered. To take advantage of this service, please send the device to our service address.

Also refer to the restrictions of this warranty concerning wear parts, consumables and missing parts as set out in the service information in these operating instructions.

