

- D** Originalbetriebsanleitung
Elektro-Kettensäge
- GB** Original operating instructions
Electric chainsaw
- F** Instructions d'origine
Tronçonneuse électrique
- I** Istruzioni per l'uso originali
Motosaga elettrica
- DK/** Original betjeningsvejledning
N EI-dreven kædesav
- S** Original-bruksanvisning
Elektrisk kedjesåg
- NL** Originele handleiding
Elektrische kettingzaag
- E** Manual de instrucciones original
Motosierra eléctrica
- P** Manual de instruções original
Electroserra
- FIN** Alkuperäiskäyttöohje
Sähkökäyttöinen ketjusaha

**Art.-Nr.: 45.017.40****I.-Nr.: 11014**

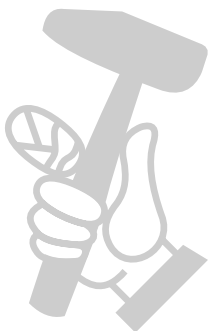

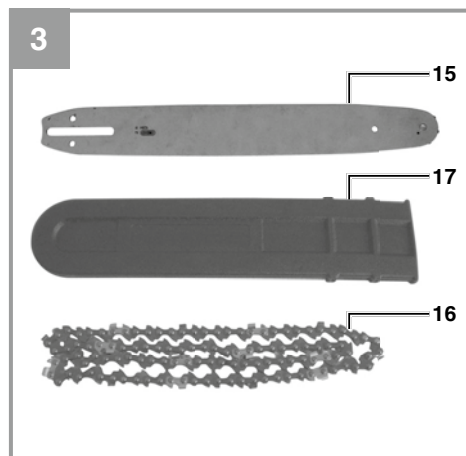

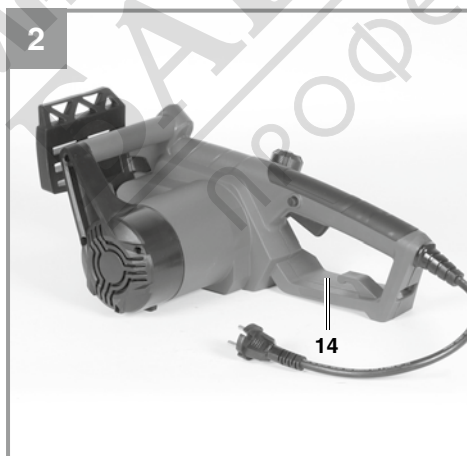
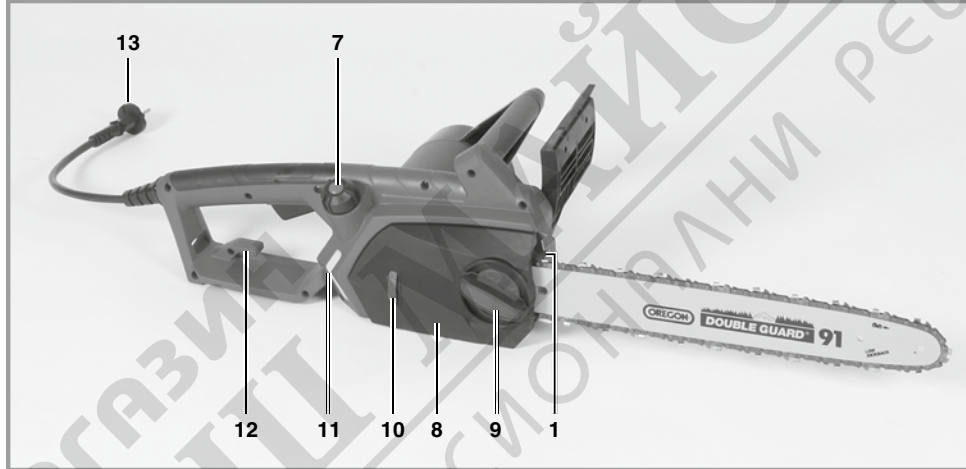
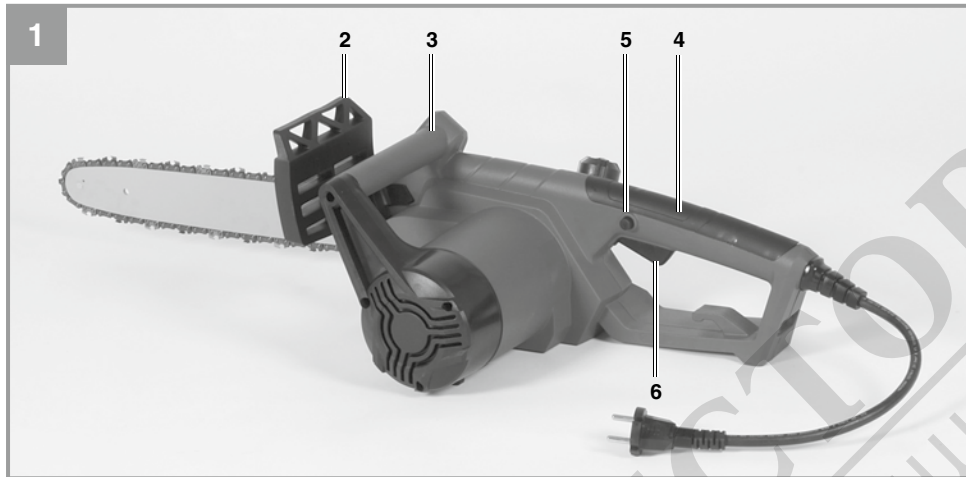
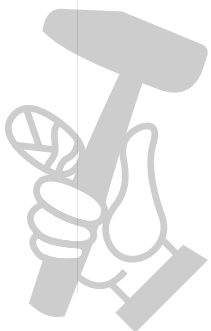
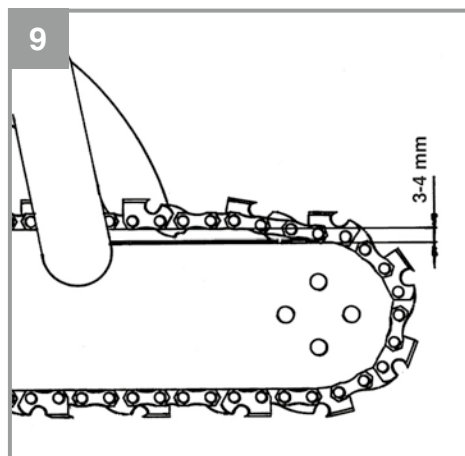
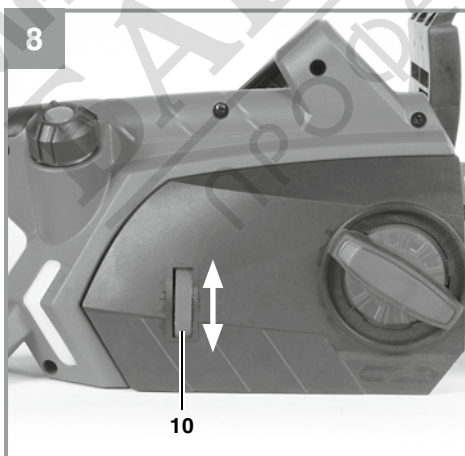
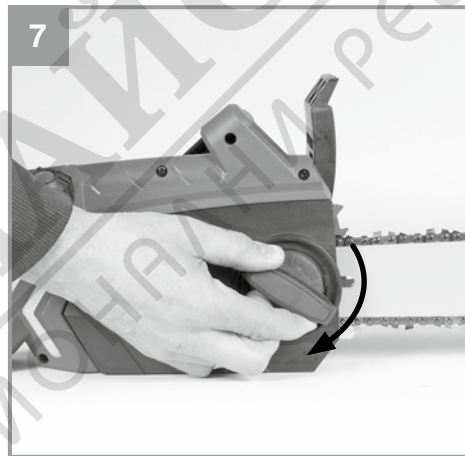
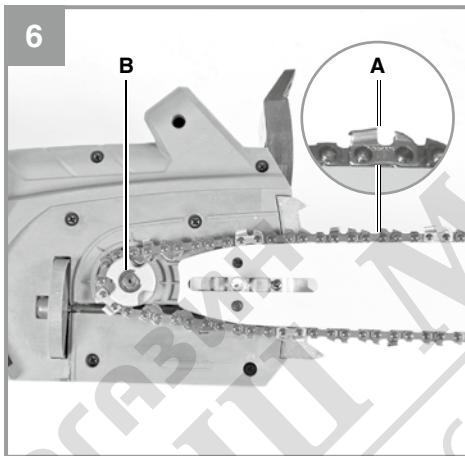
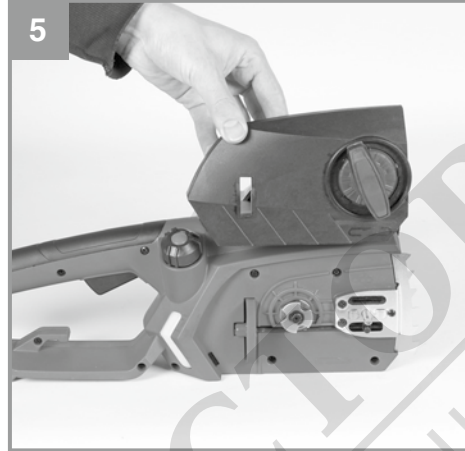
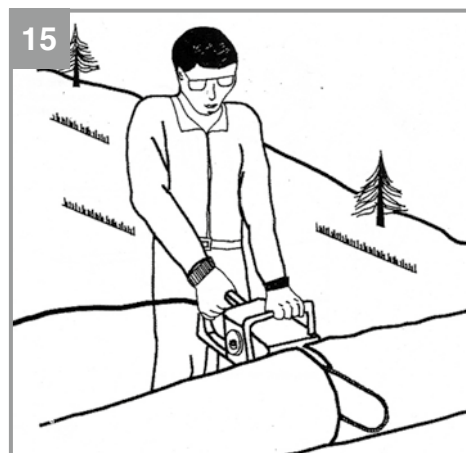
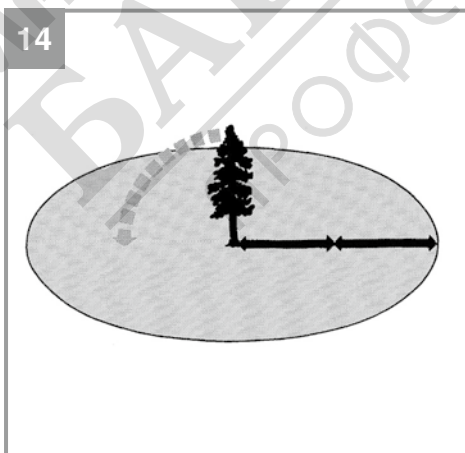
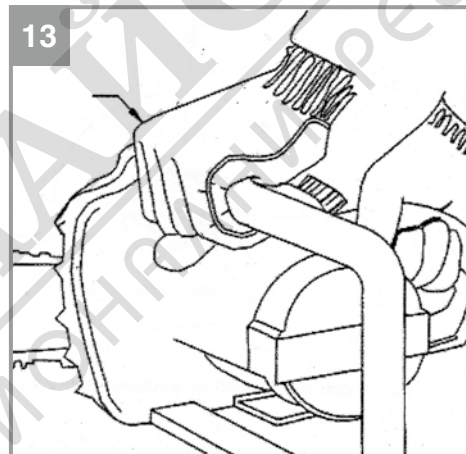
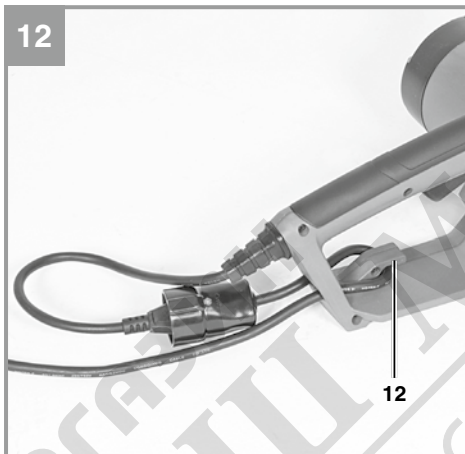
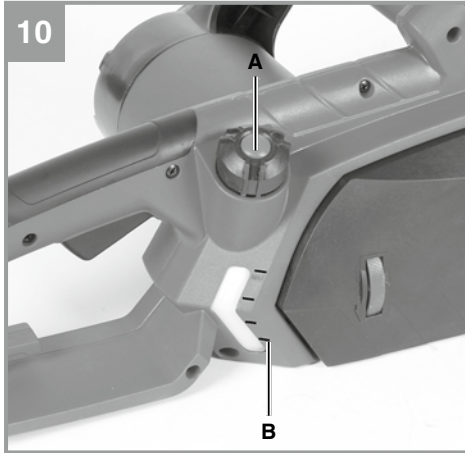

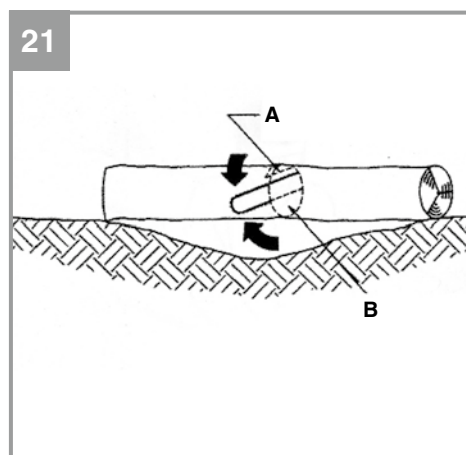
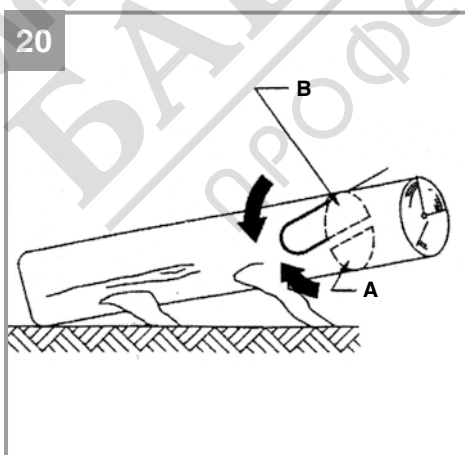
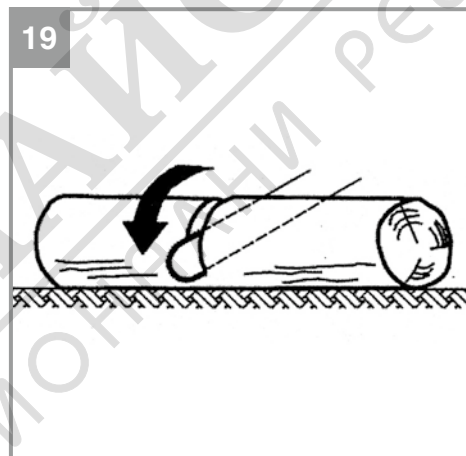
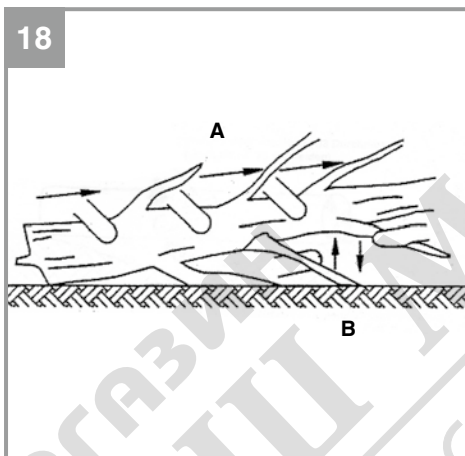
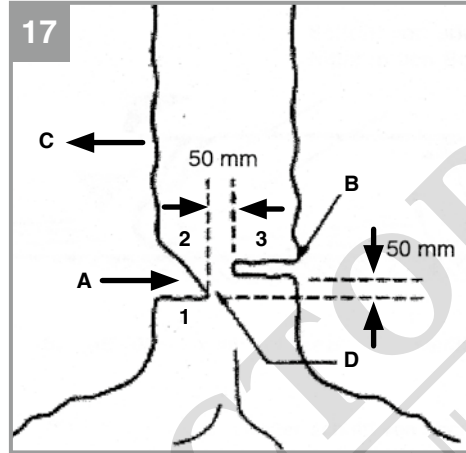
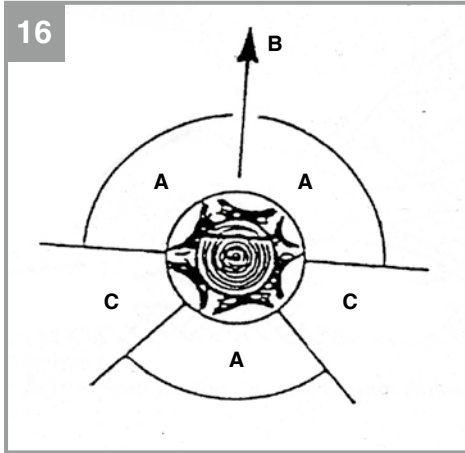

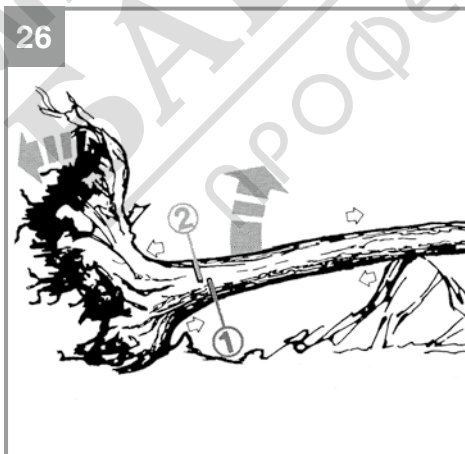
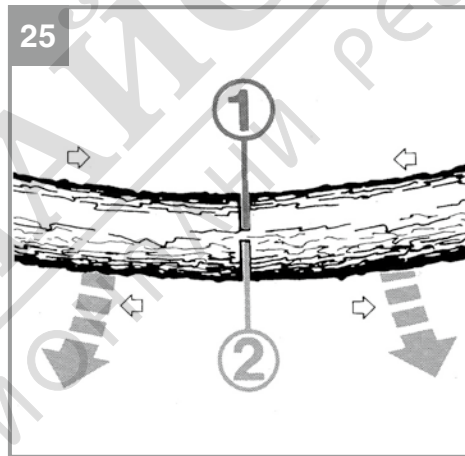
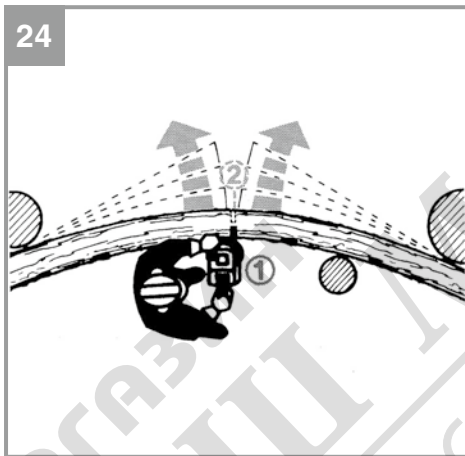
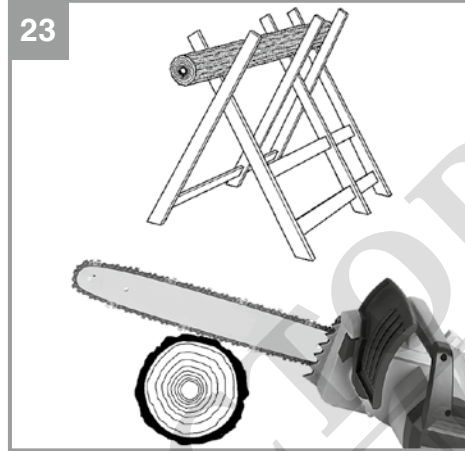

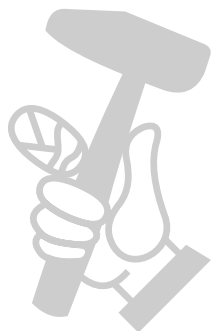
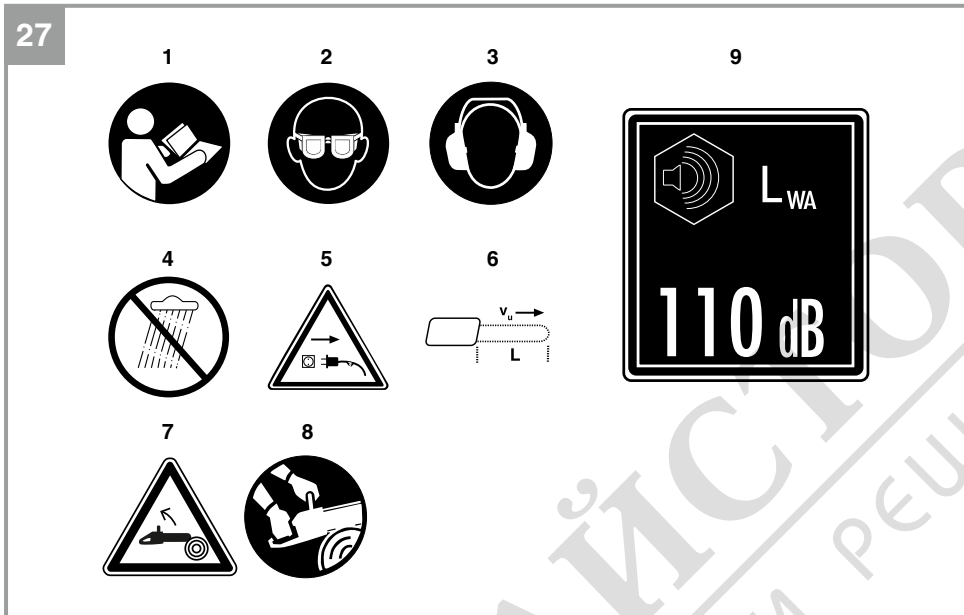
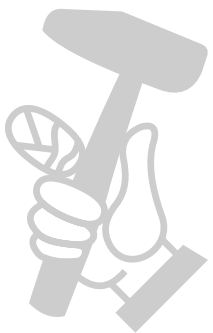

Table of contents

1. Safety regulations
2. Layout and items supplied
3. Proper use
4. Technical data
5. Before starting the equipment
6. Operation
7. Working with the chainsaw
8. Replacing the power cable
9. Cleaning, maintenance and ordering of spare parts
10. Notes on environmental protection / disposal
11. Storage
12. Troubleshooting



Danger!

When using the equipment, a few safety precautions must be observed to avoid injuries and damage. Please read the complete operating instructions and safety regulations with due care. Keep this manual in a safe place, so that the information is available at all times. If you give the equipment to any other person, hand over these operating instructions and safety regulations as well. We cannot accept any liability for damage or accidents which arise due to a failure to follow these instructions and the safety instructions.

1. Safety regulations

The corresponding safety information can be found in the enclosed booklet.

Warning!

Read all the safety information, instructions, illustrations and technical data provided on or with this power tool. Failure to adhere to the following instructions may result in electric shock, fire and/or serious injury.

Keep all the safety information and instructions in a safe place for future use.

Explanation of the symbols on the machine (Fig. 27):

1. Read the operating instructions.
2. Wear safety goggles.
3. Wear ear protectors.
4. Never expose the device to rain.
5. If the cable is damaged or cut, disconnect the power plug from the mains immediately.
6. Maximum cutting length / chain speed
 v_c : 15 m/s
7. Kick-back might result in fatal injuries from cuts.
8. Always hold the chainsaw firmly with both hands.
9. Guaranteed sound power level

2. Layout and items supplied**2.1 Layout (Fig. 1-3)**

1. Claw stop
2. Front hand guard
3. Front handle
4. Rear handle
5. Safety lock-off
6. ON/OFF switch
7. Oil tank cover

8. Chain wheel cover
9. Fixing screw for the chain wheel cover
10. Chain tensioning screw
11. Chain oil fill level indicator
12. Cable strain-relief clamp
13. Power cable
14. Rear hand guard
15. Cutter rail
16. Saw chain
17. Cutter guard

2.2 Items supplied

Please check that the article is complete as specified in the scope of delivery. If parts are missing, please contact our service center or the sales outlet where you made your purchase at the latest within 5 working days after purchasing the product and upon presentation of a valid bill of purchase. Also, refer to the warranty table in the service information at the end of the operating instructions.

- Open the packaging and take out the equipment with care.
- Remove the packaging material and any packaging and/or transportation braces (if available).
- Check to see if all items are supplied.
- Inspect the equipment and accessories for transport damage.
- If possible, please keep the packaging until the end of the guarantee period.

Danger!

The equipment and packaging material are not toys. Do not let children play with plastic bags, foils or small parts. There is a danger of swallowing or suffocating!

- Original operating instructions
- Safety instructions

3. Proper use

The chainsaw is intended for felling trees and for cutting trunks, branches, wooden beams, boards etc. and can be used for cross cuts and longitudinal cuts. It is not suitable for cutting any materials other than wood.

The equipment is to be used only for its prescribed purpose. Any other use is deemed to be a case of misuse. The user / operator and not the manufacturer will be liable for any damage or inju-

ries of any kind caused as a result of this.

Please note that our equipment has not been designed for use in commercial, trade or industrial applications. Our warranty will be voided if the machine is used in commercial, trade or industrial businesses or for equivalent purposes.

4. Technical data

Mains voltage: 220-240 V ~ 50/60 Hz
 Power rating: 2200 W
 Idling speed: 7800 rpm
 Cutter rail length: 406 mm
 Cutting length, max.: 375 mm
 Cutting speed at rated rpm: 15 m/s
 Oil tank capacity: 150 ml
 Weight with cutter rail and chain: 5,6 kg
 Protection class: II / 

Danger!

Sound and vibration

Sound and vibration values were measured in accordance with EN 62841.

L_{pA} sound pressure level 93,8 dB(A)
 K_{pA} uncertainty 3 dB
 L_{WA} sound power level 107 dB(A)
 K_{WA} uncertainty 3 dB
 L_{WA} sound power level guaranteed 110 dB(A)

Wear ear-muffs.

The impact of noise can cause damage to hearing.

Total vibration values (vector sum of three directions) determined in accordance with EN 62841-1 and EN 62841-4-1.

Front Handle under load

Vibration emission value $a_h = 3.46 \text{ m/s}^2$
 K uncertainty = 1.5 m/s^2

Rear Handle under load

Vibration emission value $a_h = 5.89 \text{ m/s}^2$
 K uncertainty = 1.5 m/s^2

- The quoted total vibration value and the quoted noise emission value were measured in accordance with standardized test procedures and can be used to compare one electric tool with another.

- The quoted total vibration value and the quoted noise emission value can also be used to make an initial assessment of exposure.

Warning:

- The vibration and noise emission levels during actual use may vary from the values quoted, depending on the way in which the electric tool is used and, in particular, on the type of workpiece being processed.
- Try to keep the exposure to vibrations and noise as low as possible. Exposure to vibrations can be reduced by wearing gloves when using the tool, for example, and by limiting the amount of operating time. All stages of the operating cycle must be considered (for example, times in which the electric tools are switched off and times in which the tool is switched on but operates without load).

Keep the noise emissions and vibrations to a minimum.

- Only use appliances which are in perfect working order.
- Service and clean the appliance regularly.
- Adapt your working style to suit the appliance.
- Do not overload the appliance.
- Have the appliance serviced whenever necessary.
- Switch the appliance off when it is not in use.
- Wear protective gloves.

5. Before starting the equipment

Before you connect the equipment to the mains supply make sure that the data on the rating plate are identical to the mains data.

Warning!

Always pull the power plug before making adjustments to the equipment.

Caution: Do not connect the chainsaw to the power supply until it has been fully assembled and the chain tension has been adjusted. Always wear protective gloves when working on the chainsaw to protect yourself against injury.

5.1 Assembly of the cutter rail and the saw chain

- Carefully unpack all parts and check that they are complete (Fig. 2-3).
- Undo the fixing screw of the chain wheel cover (Fig. 4).

- Take off the chain wheel (Fig. 5).
- Lay the chain as shown in the groove which runs around the cutter rail (Fig. 6/Item A).
- Insert the cutter rail and chain as shown in the mounting in the chainsaw (Fig. 6). At the same time guide the chain around the chain wheel (Fig. 6/ Item B).
- Attach the chain wheel cover and secure it with the fixing screw (Fig. 7). Caution: Do not fully tighten the fixing screw until after adjusting the chain tension (refer to point 5.2).

5.2 Tensioning the saw chain

Warning! Always disconnect the mains plug before performing any checks or adjustments. Always wear protective gloves when working on the chainsaw to protect yourself against injury.

- Undo the fixing screw of the chain wheel cover a few turns (Fig. 4).
- Adjust the chain tension with the chain tensioning screw (Fig. 8). Turning the screw clockwise increases the tension, turning it counter-clockwise decreases the chain tension. The saw chain is correctly tensioned if it can be lifted around 3-4 mm in the middle of the cutter rail (Fig. 9).
- Tighten the fixing screw of the chain wheel cover.

Danger! All of the chain links must lie properly in the guide groove of the cutter rail.

Notes on tensioning the chain:

The saw chain must be properly tensioned to ensure safe operation. You can tell that the chain tension is perfect if the saw chain can be lifted by around 3-4 mm in the middle of the cutter rail. As the saw chain heats up during cutting and thus changes in length, please check the chain tension every 10 minutes and adjust it again as required. This applies in particular to new saw chains. When you have finished working slacken the chain again, as the chain will shorten when it cools down. This will prevent the chain from being damaged.

5.3 Saw chain lubrication

Warning! Always disconnect the mains plug before performing any checks or adjustments. Always wear protective gloves when working on the chainsaw to protect yourself against injury.

Notice! Never operate the chain if it is not lubricated with saw chain oil. Use of the chainsaw without saw chain oil or if the oil level is below the "min" mark (Fig. 10/ Item B) will damage the

chainsaw.

Notice! Be aware of the temperature conditions: different lubricants with completely different viscosities are required at different ambient temperatures. At lower temperatures you will need low viscosity oils in order to achieve a sufficient lubricating film. However, if the same low viscosity oil is used during the summer it will become even thinner due to the ambient temperatures alone, and as a result the lubricating film could break down, causing the chain to overheat and become damaged. In addition, the chain oil would burn and produce unnecessary pollutants.

Filling the oil tank:

- Place the chainsaw on a flat surface.
- Clean the area around the oil tank cover (Fig. 10/Item A) and then clean the oil tank cover.
- Fill the tank with saw chain oil. In the process, make sure that no dirt enters the tank, as this could cause the oil nozzle to become blocked.
- Close the oil tank cover.

6. Operation

6.1 Connecting to the mains supply

- Connect the power cable to a suitable extension cable. Make sure that the extension cable is designed for the power rating of the chainsaw.
- Secure the extension cable as shown in Fig. 12 to protect it against pulling forces and accidental disconnection.
- Connect the extension cable to a professionally installed safety mains outlet with ground contact.

We recommend using a cable with a bright and highly visible color, e.g. red or yellow. This will reduce the risk of accidentally damaging it with the chainsaw.

6.2 Switching on/off

Switching on

- Hold the chainsaw by the handles with both hands as shown in Fig. 13 (thumbs under the handles).
- Press and hold the safety lock-off (Fig. 1/Item 5).
- Switch on the chainsaw at the ON/OFF

switch. You can then release the safety lock-off.

Switching off

Release the ON/OFF switch (Fig. 1/Item 6).

The integrated brake will bring the running chainsaw to a standstill within a very short space of time. Always disconnect the mains plug when you stop working, even if it is only for a short time.

Warning! Always carry the saw by the front handle. If the saw is plugged in and you carry it by the rear handle (which is where the switches are located), then there is a risk that you could accidentally press the safety lock-off and the ON/OFF switch at the same time, and the chainsaw could inadvertently start up.

6.3 Safety devices

Motor brake

The motor brakes the saw chain as soon as the ON/OFF switch (Fig. 1/Item 6) is released or the power supply is interrupted. This significantly reduces the risk of injury that would otherwise be present if the chain continued to run after being switched off or disconnected.

Chain brake

The chain brake is a safety mechanism which is triggered via the front hand guard (Fig. 1/Item 2). If kickback causes the chainsaw to suddenly jerk back then the chain brake trips and stops the saw chain in less than 0.1 seconds. You must check the operation of the chain brake on a regular basis. To do this, fold the hand guard (Fig. 1/Item 2) forward and briefly switch the chainsaw on. The saw chain must not start up.

Pull back the front hand guard (Fig. 1/Item 2) until it engages to release the chain brake.

Danger! Never use the saw if the safety equipment is not working properly. Never try to repair safety related protection systems yourself – always have any work done by our service department or by a similarly qualified workshop.

Hand guard

The front hand guard (which also acts as the chain brake at the same time) (Fig. 1/Item 2) and the rear hand guard (Fig. 2/Item 14) protect against finger injuries resulting from contact with the saw chain if the chain breaks because it is overloaded.

7. Working with the chainsaw

7.1 Preparations

To ensure that you can work safely, check the following points before every use:

Condition of the chain saw

Inspect the chainsaw before the start of work for damage to the housing, the power cable, the saw chain and the cutter rail. Never use a chainsaw which is obviously damaged.

Oil container

Fill level of the oil container. Even while working, keep checking that sufficient oil is in the system. To avoid damaging the chainsaw, never run the saw if there is no oil in the system or if the oil drops below the "min" mark (Fig. 10/Item B). On average, a single filling will last around 15 minutes depending on the number of pauses in cutting and the loads involved.

Saw chain

Tension of the saw chain, condition of the cutting elements. The sharper the chainsaw, the easier and more controllable it is to operate the chainsaw. The same also applies to the chain tension. Again, while working also check the chain tension every 10 minutes in order to increase your safety. New saw chains in particular often tend to expand more.

Chain brake

Check the operation of the chain brake as described in the chapter "Safety devices" and then release it.

Safety clothing

Always wear appropriate tight-fitting safety clothing like special trousers which protect against cuts, protective gloves and safety shoes.

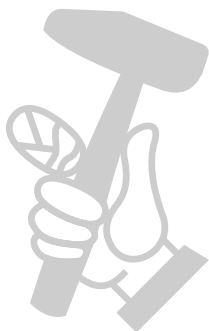

Hearing protection and protective goggles.

When felling trees or performing forest work, always wear a protective helmet with integral face and hearing protection. This will offer protection against falling branches and any branches if they spring back.

7.2 Description of the correct procedures for basic use of the chainsaw**Felling a tree (Figs. 14-17)**

If two or more persons are working at the same time on felling and cutting back then the minimum distance between the tree being felled and the tree being cut back should be at least twice the height of the tree being felled (Fig. 14). When felling trees, care must be taken to ensure that no other persons are endangered, no power supply lines are hit and no material damage is caused to equipment or property. In the event that a tree comes into contact with a power supply line, the responsible power supply company should be informed immediately.

When working with the saw on a slope, the operator of the chainsaw must be standing at a higher point on the slope than the tree being felled, as the tree will roll or slip downhill once it has been felled (Fig. 15).

Before felling the tree you must first plan and if necessary clear an escape route. This escape route must lead away diagonally in the opposite direction to the expected fall direction – this can be seen in Fig. 16 (A= danger zone, B= direction of fall, C= escape zone).

Before felling the tree you must take into account the natural inclination of the tree, the location of larger branches and the wind direction, as this will help you to correctly determine the direction in which the tree will fall.

Dirt, stones, loose bark, nails, staples and wire must be removed from the tree.

Making the felling notch (Fig. 17)

Cut a notch (A) at right angles to the fall direction to a depth of 1/3 of the tree diameter as shown in Fig. 17. First make the lower horizontal felling notch (1). This prevents the saw chain or the guide rail from becoming trapped when the second felling notch is made.

Making the felling cut (Fig. 17)

The felling cut should be positioned at least 50 mm above the horizontal felling notch. Make the felling cut (B) parallel to the horizontal felling notch. The felling cut should be cut to a depth which leaves a thin strip (felling hinge strip) (D) which can act as a hinge. This strip prevents the tree from rotating and falling in the wrong direction. Do not cut through the strip. When the felling cut gets close to the strip the tree should start to fall. If it becomes clear that the tree may well fall in a different direction to the desired fall direction (C) or it starts to lean back and traps the saw chain, interrupt the felling cut and insert wedges made of wood, plastic or aluminum to open out the cut and control the lean of the tree until it leans in the required direction.

When the tree starts to fall, remove the chainsaw from the cut, switch it off, place it on the ground and exit the danger zone via the planned escape route. Watch out for falling branches and take care not to trip.

Removing branches

Here we are talking about removing branches from the felled tree. When removing branches, leave any downward facing branches which are supporting the tree until the trunk of the tree has been cut up. Smaller branches should be removed as shown in Fig. 18 (A= cutting direction when removing branches, B= keep away from the ground! Supporting branches should be left until the trunk is cut up) in a single cut from the bottom to the top. Any branches which are under tension should be cut from the bottom to the top to prevent the saw from becoming trapped.

Cutting the tree trunk into lengths

Here we are looking at the process of cutting the felled tree into sections. Make sure you have a sure footing and distribute your body weight evenly onto both feet. If possible the trunk should be underlaid and supported with branches, beams or wedges. For easy cutting follow the simple instructions below.

If the full length of the tree trunk is evenly supported as shown in Fig. 19 then proceed by cutting from the top down. Take care not to cut into the ground in the process.

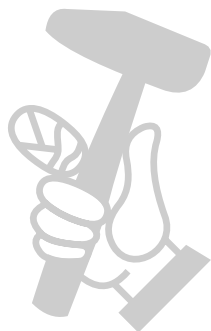

If the weight of the tree trunk is resting on one end as shown in Fig. 20, first cut through 1/3 of the trunk diameter from the underside (A) in order to prevent it from splintering. Make the second cut from the top (2/3 of the diameter) to the height of the first cut (B) (this prevents the chainsaw from being trapped).

If the weight of the tree trunk is resting on both ends as shown in Fig. 21, first cut through 1/3 of the trunk diameter from the top (A) in order to prevent it from splintering. Make the second cut from underneath (2/3 of the diameter) to the height of the first cut (B) (this prevents the chainsaw from being trapped).

When working with the saw on a slope, always position yourself at a higher point on the slope above the tree as shown in Fig. 15. In order to retain full control at the moment when the cut goes through, reduce pressure towards the end of the cut without releasing your firm grip on the handles of the chainsaw. Take care to ensure that the chainsaw does not touch the ground. After completing the cut, wait for the chain saw to come to a standstill before removing the chainsaw. Always switch off the motor of the chainsaw before moving from tree to tree.

7.3 Kickback

The term “kickback” describes what happens when the running chainsaw suddenly kicks upward and backward. Usually, this is caused by contact between the tip of the cutter rail and the workpiece or the saw chain becoming trapped. In the event of kickback, large forces occur suddenly and violently. As a result, the chainsaw usually reacts uncontrollably. This can often result in very serious injuries to the worker or persons in the vicinity. The risk of kickback is particularly great when performing cross cuts, angled cuts and longitudinal cuts, as it is not possible to use the claw stop on these cuts. You should therefore avoid these cuts as far as possible and take particular care when they are unavoidable.

The risk of kickback is at its greatest when the saw is positioned for a cut in the region of the tip of the cutter rail, as the leverage effect is greatest there (Fig. 22). It is therefore safest to position the saw flat and as close as possible to the claw stop before making the cut (Fig. 23).

Warning!

- Make sure that the chain tension is always correctly adjusted.
- Only use a chainsaw if it is in perfect working order.
- Only work with a saw chain that has been properly sharpened in accordance with the instructions.
- Never operate the saw above shoulder height.
- Never cut with the upper edge or the tip of the sword.
- Always hold the chainsaw firmly with both hands.
- Whenever possible, use the claw stop as a leverage point.

Cutting wood which is under tension

Special care is required when cutting wood which is under tension. Wood which is under tension from which it is released by cutting may in some cases react completely unpredictably and uncontrollably. In the worst case this could result in extremely severe or even fatal injuries (Fig. 24-26).

This type of work must only be performed by persons who have been specially trained.

8. Replacing the power cable

Danger!

If the power cable for this equipment is damaged, it must be replaced by the manufacturer or its after-sales service or similarly trained personnel to avoid danger.

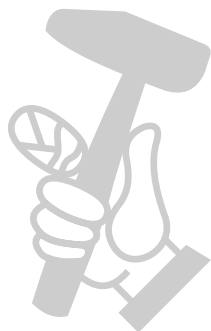

9. Cleaning, maintenance and ordering of spare parts

Danger!

- Always disconnect the mains plug before cleaning the chainsaw.
- Never immerse the unit in water or other liquids in order to clean it.
- Store the chainsaw in a safe and dry place out of the reach of children.

9.1 Cleaning

- Regularly clean the clamping mechanism by blowing it out with compressed air or cleaning it with a brush. Do not use tools for cleaning.
- Keep the handles free of grease so that you can maintain a firm grip.
- Clean the device as required with a damp cloth and, if necessary, mild washing up liquid.
- If the chainsaw is not to be used for an extended period of time then you should remove the chain oil from the tank. Briefly immerse the saw chain and the cutter rail in an oil bath and then wrap them in oil paper.

9.2 Carbon brushes

In case of excessive sparking, have the carbon brushes checked only by a qualified electrician.

Danger! The carbon brushes should not be replaced by anyone but a qualified electrician.

9.3 Maintenance

Replacing the saw chain and cutter rail

The cutter rail needs to be replaced if

- the guide groove of the cutter rail is worn;
- the nose sprocket in the cutter rail is damaged or worn.

Proceed as described in the section "Assembly of the cutter rail and the saw chain".

Checking the automatic chain lubrication

You should check the operation of the automatic chain lubrication system on a regular basis in order to guard against overheating and the associated damage to the cutter rail and the saw chain. To do this, point the tip of the cutter rail towards a smooth surface (board, section of a cut tree) and allow the chainsaw to run.

If an increasing oil trace becomes evident during this process then the automatic chain lubrication system is working properly. If no clear oil trace is

evident then please refer to the corresponding instructions in "Troubleshooting". If the information contained there still fails to remedy the situation then please contact our service department or another similarly qualified workshop.

Danger! Do not actually touch the surface with the tip of the cutter rail when performing this test. Keep a safe distance (approx. 20 cm).

Sharpening the saw chain

Effective working with the chainsaw is only possible if the saw chain is in good condition and sharp. This also reduces the risk of kickback. The saw chain can be re-sharpened by any dealer. Do not attempt to sharpen the saw chain yourself unless you have the necessary special tools and experience.

9.4 Ordering replacement parts:

Please quote the following data when ordering replacement parts:

- Type of machine
- Article number of the machine
- Identification number of the machine
- Replacement part number of the part required

For our latest prices and information please go to www.Einhell-Service.com

10. Notes on environmental protection / disposal

The equipment is supplied in packaging to prevent it from being damaged in transit. The raw materials in this packaging can be reused or recycled. The equipment and its accessories are made of various types of material, such as metal and plastic. Never place defective equipment in your household refuse. The equipment should be taken to a suitable collection center for proper disposal. If you do not know the whereabouts of such a collection point, you should ask in your local council offices.

11. Storage

Store the equipment and accessories out of children's reach in a dark and dry place at above freezing temperature. The ideal storage temperature is between 5 and 30 °C. Store the electric tool in its original packaging.

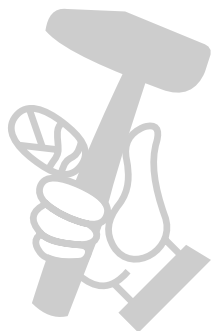

МАГАЗИН
БАШ МАЙСТОРА®
ПРОФЕСИОНАЛНИ РЕШЕНИЯ

12. Troubleshooting

Danger!

Before troubleshooting, switch off the tool and disconnect the mains plug.

The table below contains a list of fault symptoms and explains what you can do to remedy the problem if your tool fails to work properly. If the problem still persists after working through the list then please contact your nearest service workshop.

Cause	Fault	Remedy
Chainsaw does not work at all	<ul style="list-style-type: none"> - Quick stop brake has been triggered - No power supply - Defective mains outlet - Power extension cable damaged - Defective fuse 	<ul style="list-style-type: none"> - Pull the hand protection back to the normal position. - Check the power supply. - Try an alternative source of electrical power, replace if necessary. - Check the cable and replace as required. - Replace the fuse.
Chainsaw operates intermittently	<ul style="list-style-type: none"> - Power cable damaged - Loose connection (external) - Loose connection (internal) - ON/OFF switch defective 	<ul style="list-style-type: none"> - Consult a specialist workshop. - Consult a specialist workshop. - Consult a specialist workshop. - Consult a specialist workshop.
Saw chain dry	<ul style="list-style-type: none"> - No oil in the tank - Oil tank cap breather blocked - Oil outlet blocked 	<ul style="list-style-type: none"> - Fill up with oil. - Clean the oil tank cap. - Clear the oil outlet.
Chain brake does not work	<ul style="list-style-type: none"> - Problem with the switch mechanism in the front hand guard 	<ul style="list-style-type: none"> - Consult a specialist workshop.
Chain/guide rail hot	<ul style="list-style-type: none"> - No oil in the tank - Oil tank cap breather blocked - Oil outlet blocked - Blunt chain 	<ul style="list-style-type: none"> - Fill up with oil. - Clean the oil tank cap. - Clear the oil outlet - Re-sharpen or replace the chain.
Chainsaw juddering, vibrating or not sawing properly	<ul style="list-style-type: none"> - Chain tension too loose - Blunt chain - Worn chain - Saw teeth pointing in the wrong direction 	<ul style="list-style-type: none"> - Adjust the chain tension. - Re-sharpen or replace the chain. - Replace the chain. - Reinstall the saw chain with the teeth facing in the correct direction.



For EU countries only

Never place any electric power tools in your household refuse.

To comply with European Directive 2012/19/EC concerning old electric and electronic equipment and its implementation in national laws, old electric power tools have to be separated from other waste and disposed of in an environment-friendly fashion, e.g. by taking to a recycling depot.

Recycling alternative to the return request:

As an alternative to returning the equipment to the manufacturer, the owner of the electrical equipment must make sure that the equipment is properly disposed of if he no longer wants to keep the equipment. The old equipment can be returned to a suitable collection point that will dispose of the equipment in accordance with the national recycling and waste disposal regulations. This does not apply to any accessories or aids without electrical components supplied with the old equipment.

Please note that batteries and lamps (e.g. light bulbs) must be removed from the tool before it is disposed of.

The reprinting or reproduction by any other means, in whole or in part, of documentation and papers accompanying products is permitted only with the express consent of the Einhell Germany AG.

Subject to technical changes

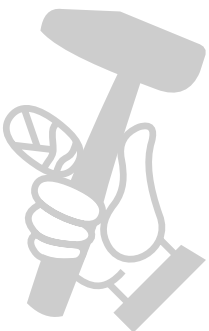

Service information

We have competent service partners in all countries named on the guarantee certificate whose contact details can also be found on the guarantee certificate. These partners will help you with all service requests such as repairs, spare and wearing part orders or the purchase of consumables.

Please note that the following parts of this product are subject to normal or natural wear and that the following parts are therefore also required for use as consumables.

Category	Example
Wear parts*	Cutter bar, carbon brushes
Consumables*	Saw chain
Missing parts	

* Not necessarily included in the scope of delivery!

In the effect of defects or faults, please register the problem on the internet at www.Einhell-Service.com. Please ensure that you provide a precise description of the problem and answer the following questions in all cases:

- Did the equipment work at all or was it defective from the beginning?
- Did you notice anything (symptom or defect) prior to the failure?
- What malfunction does the equipment have in your opinion (main symptom)? Describe this malfunction.



Warranty certificate

Dear Customer,

All of our products undergo strict quality checks to ensure that they reach you in perfect condition. In the unlikely event that this equipment develops a fault, please contact our service department at the address shown on this guarantee card. You can also contact us by telephone using the service number shown. Please note the following terms under which guarantee claims can be made:

1. These guarantee terms apply solely to consumers, i.e. natural persons, who do not want to use this product in connection with either their commercial or other self-employed activities. These guarantee terms regulate additional guarantee services which the undermentioned manufacturer promises to buyers of its new products in addition to their statutory rights of guarantee. Your statutory rights of guarantee are not affected by this guarantee. Our guarantee is free of charge to you.
2. The guarantee services cover only defects due to material or manufacturing faults on the new product which you have bought in the European Union from the undermentioned manufacturer and are limited to either the rectification of said defects or the replacement of the product, whichever we prefer. Please note that only equipment under the brand name "Professional" has been designed for use in commercial, trade or professional applications. For all other products the guarantee is invalidated if the equipment is used within the guarantee period in commercial, trade or industrial applications or for other equivalent activities.
3. Our guarantee does not cover:
 - Damage to the equipment caused by failure to comply with the installation/assembly instructions or by unprofessional installation; damage caused by failure to comply with the operating instructions (e.g. connection to the wrong mains voltage or current type); damage caused by failure to comply with the maintenance and safety regulations; damage caused by exposing the equipment to abnormal environmental conditions; damage resulting from poor care and maintenance.
 - Damage to the equipment caused by misuse or incorrect applications (e.g. overloading the equipment or using non-approved attachments or accessories); damage caused by foreign bodies (e.g. sand, stones, dust, ...) getting inside the equipment. Damage in transit; damage caused by force or external influences (e.g. by dropping the equipment).
 - Damage to the equipment or parts of the equipment which is owed to use-related, normal or otherwise natural wear. For example, batteries and battery packs are manufactured with a cycle limit for design-related reasons. Wear is negatively influenced in particular by load demands and charging speeds as well as exposure to heat, cold, vibration and impact.
4. The guarantee is valid for a period of 2 years starting from the purchase date of the equipment. Guarantee claims must be submitted before the end of the guarantee period and within two weeks of the defect being noticed. No guarantee claims will be accepted after the end of the guarantee period. The original guarantee period remains applicable to the equipment even if repairs are carried out or parts are replaced. In such cases, the work performed or parts fitted will not result in an extension of the guarantee period, and no new guarantee will become active for the work performed or for any replacement parts fitted. This also applies if on-site service is used.
5. To assert your guarantee claim, register the defective equipment at: www.Einhell-Service.com. You will need to provide proof of purchase of the new item of equipment. Equipment returned without such proof or without a rating plate are excluded from the guarantee services because of the lack of traceability. If the defect is covered by our guarantee, then either the item in question will be repaired immediately and returned to you or we will send you a new replacement.
6. If you have taken the equipment with you to a different EU country than where you bought it, we will arrange for a local service partner to provide the guarantee services. If you take the equipment outside the EU, the guarantee will not apply.

Of course, we are also happy to offer a chargeable repair service for any defects which are not covered or no longer covered by the scope of this guarantee. To take advantage of this service, please send the equipment to our service address. We draw attention to the restrictions of this guarantee concerning wear parts, consumables and missing parts as presented in the service information included in this operating manual.

Warrantor/ Service:

Einhell UK Ltd, Unit 10, 1st Floor, Champion's Business Park, Arrowe Brook Road, Upton, Wirral, CH49 0UQ