

D Originalbetriebsanleitung
Einhand-Akku-Kettensäge
WARNUNG: DIESE KETTENSÄGE DARF NUR VON AUSGEBILDETEN BAUMPFLLEGEARBEITSKRÄFTEN EINGESETZT WERDEN. VERWENDUNG OHNE SCHULUNG KANN ZU SCHWEREN VERLETZUNGEN FÜHREN.

GB Original operating instructions
One-handed cordless chainsaw
WARNING: THIS CHAIN SAW IS ALLOWED TO BE USED ONLY BY TRAINED TREE MAINTENANCE WORKERS. USE WITHOUT TRAINING COULD LEAD TO SERIOUS INJURIES.

F Instructions d'origine
Tronçonneuse sans fil une main
AVERTISSEMENT : CETTE TRONÇONNEUSE DOIT ÊTRE UNIQUEMENT UTILISÉE PAR UN PERSONNEL D'ENTRETIEN DES ARBRES DUMENT QUALIFIÉ. TOUTE UTILISATION DE LA TRONÇONNEUSE SANS FORMATION PEUT ENTRAÎNER DES BLESSURES GRAVES.

I Istruzioni per l'uso originali
Elettrosega monomano a batteria
AVVERTIMENTO: QUESTA SEGA A CATENA DEVE ESSERE USATA SOLO DA ESPERTI DI ARBORICOLTURA ADEGUATAMENTE ISTRUITI. L'UTILIZZO DA PARTE DI PERSONE NON ISTRUITE IN MERITO PUÒ CAUSARE LESIONI GRAVI.

DK/ Original betjeningsvejledning
N Enhåndet akkudrevet kædesav
ADVARSEL: DENNE KÆDESAV MÅ KUN BRUGES AF PERSONER, DER ER UDDANNEDE TIL AT SAVE I TRÆER. BRUG UDEN INSTRUKTION KAN FØRE TIL ALVORLIGE KVÆSTELSER.

S Original-bruksanvisning
Batteridrivnen enhandsmotorsåg
WARNING! DENNA MOTORSÅG FÅR ENDAST ANVÄNDAS AV UTBILDADE ARBORISTER. ANVÄNDNING UTAN UTBILDNING KAN LEDA TILL ALLVARLIGA PERSONSKADOR.

CZ Originální návod k obsluze
Jednoruční akumulátorová řetězová pila
VAROVÁNÍ: TUTO ŘETĚZOVOU PILU SMÍ POUŽÍVAT POUZE OSOBY PROŠKOLENÉ V PÉČI O STROMY. POUŽÍVÁNÍ BEZ PROŠKOLENÍ MŮŽE VÉST K TĚŽKÝM PORANĚNÍM.

SK Originálny návod na obsluhu
Jednoručná akumulátorová reťazová pila
VÝSTRAHA: TÚTO REŤAZOVÚ PÍLU SMÚ POUŽÍVAŤ LEN VYŠKOLENÍ PRACOVNÍCI ZABEZPEČUJÚCI STAROSTLIVOSŤ O STROMY. POUŽÍVANIE BEZ ZAŠKOLENIA MÔŽE VIEŠŤ K ŤAŽKÝM ZRANENIAM.

NL Originele handleiding
Eenhandige accu kettingzaag
WAARSCHUWING: DEZE KETTINGZAAG MAG ALLEEN WORDEN INGEZET DOOR VOOR HET VERZORGEN VAN BOMEN OPGELEIDE ARBEIDSKRACHTEN. GEBRUIK ZONDER SCHOLING KAN ERNSTIGE VERWONDINGEN TOT GEVOLG HEBBEN.

E Manual de instrucciones original
Motosierra monomanual inalámbrica
AVISO: ESTA MOTOSIERRA SOLO PODRÁ SER EMPLEADA POR PERSONAL FORMADO DESTINADO AL CUIDADO DE LOS ÁRBOLES. RECIBIR UNA FORMACIÓN ANTES DE UTILIZARLO PARA EVITAR SUFRIR LESIONES.

FIN Alkuperäiskäyttöohje
Akkukäyttöinen yksikäsi-ketjusaha
VAROITUS: VAIN KOULUTETUT PUUSTONHOITAJAT SAAVAT KÄYTTÄÄ TÄTÄ KETJUSAHAA. KÄYTTÄMINEN ILMAN VASTAAVAA KOULUTUSTA VOI AIHEUTTAA VAKAVIA VAMMOJA.

SLO Originalna navodila za uporabo
Enoročna akumulatorska verižna žaga
OPOZORILO: TO VERIŽNO ŽAGO LAHKO UPORABLJAJO SAMO DELAVCI, IZOBRAŽENI ZA NEGO DREVES. UPORABA BREZ USPOSABLJANJA LAHKO PRIVEDE DO HUDIH POŠKODB.

13



Art.-Nr.: 46.000.20

I.-Nr.: 21011

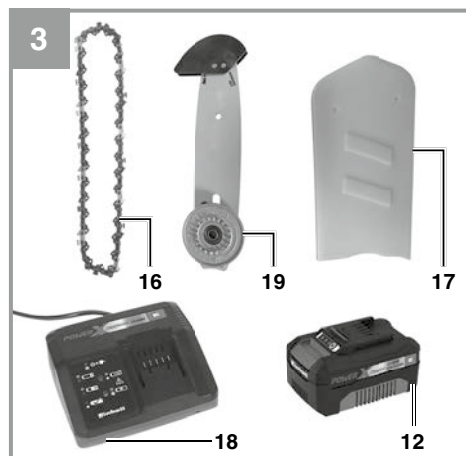
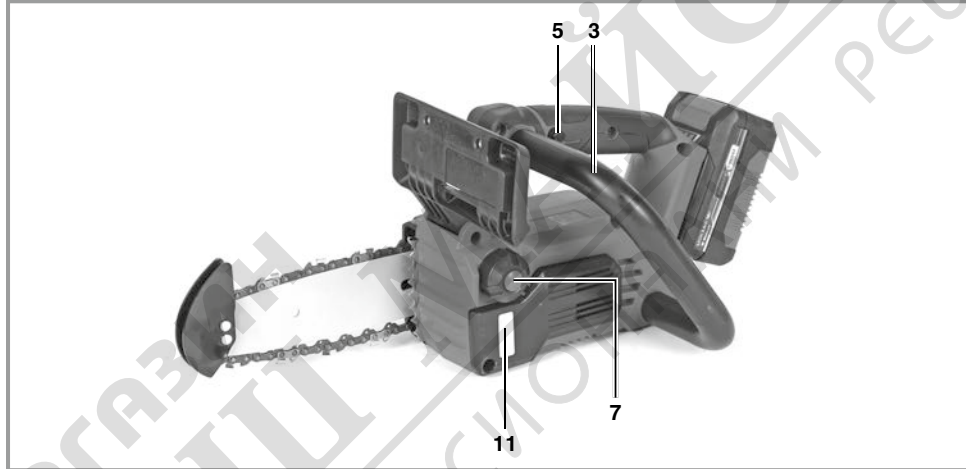
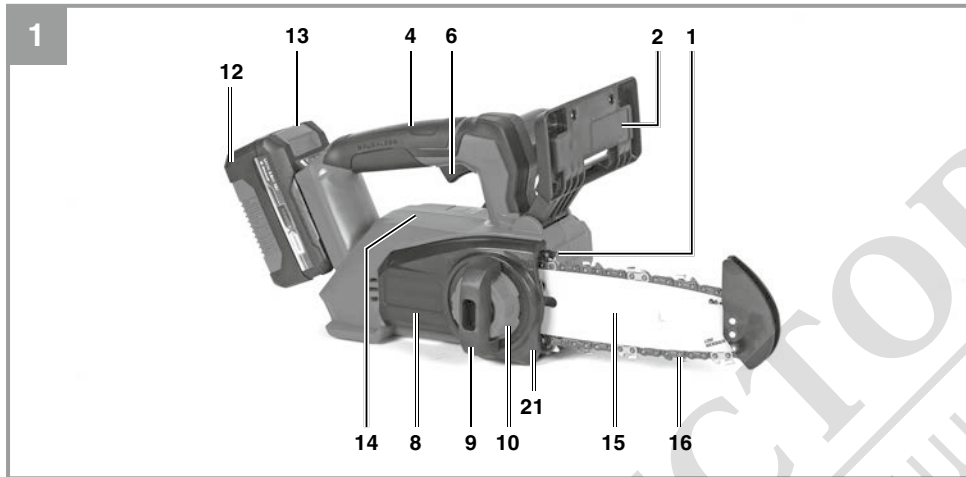

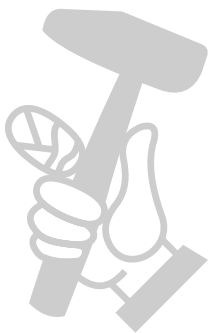
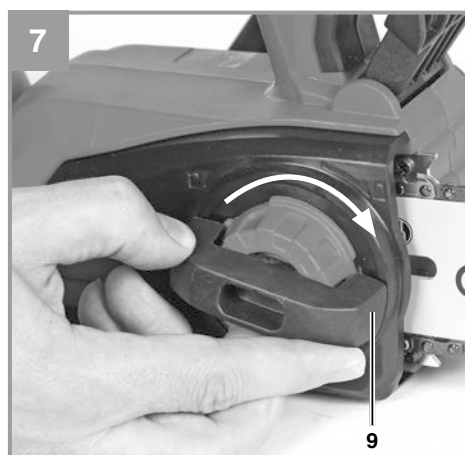
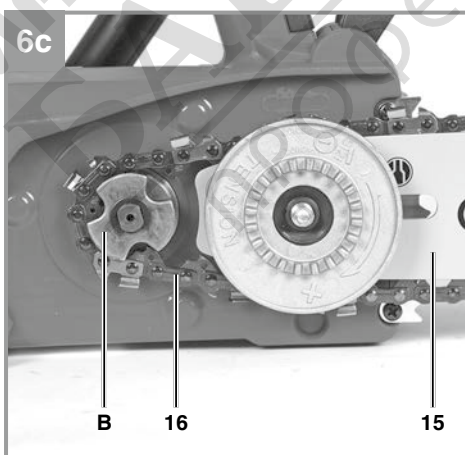
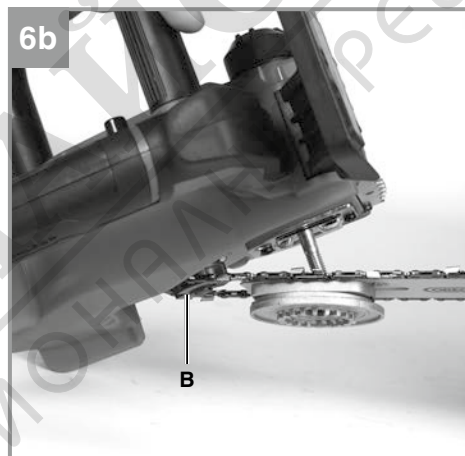
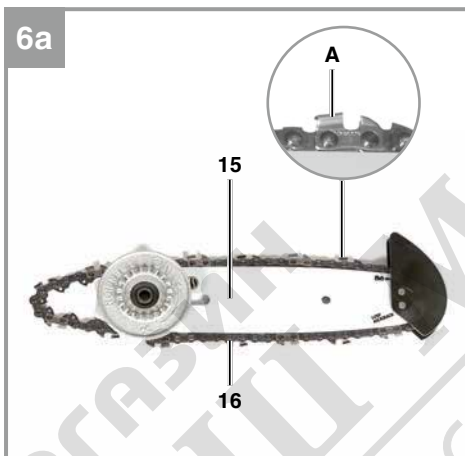
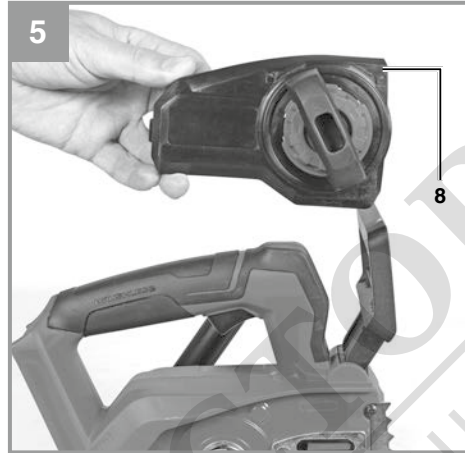
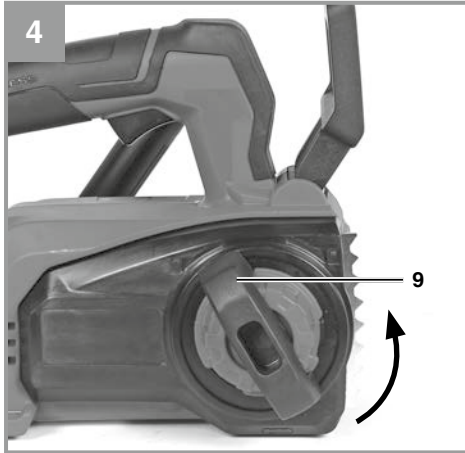

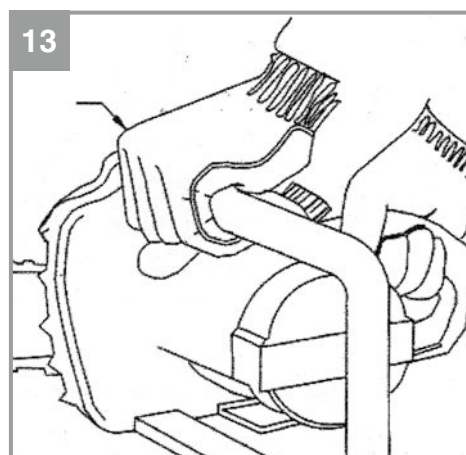
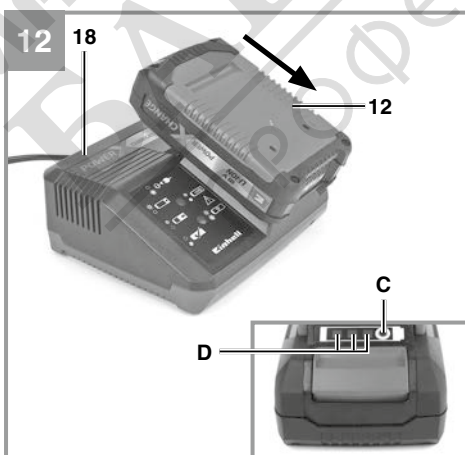
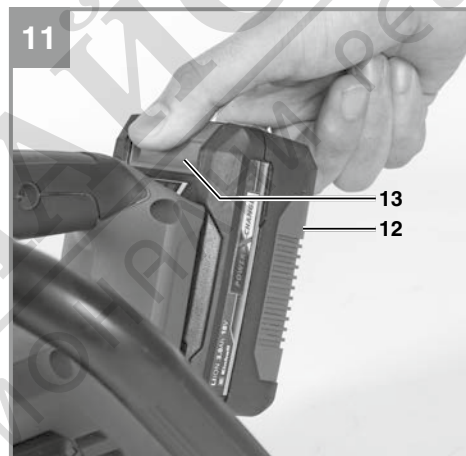
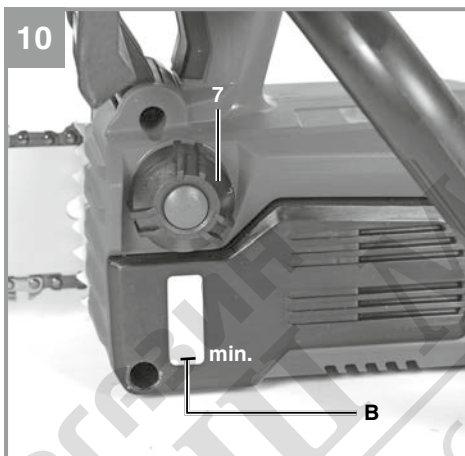
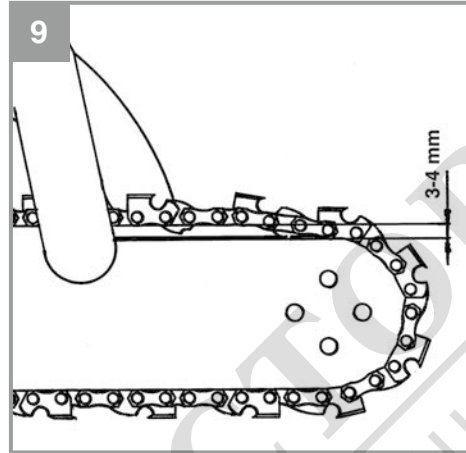
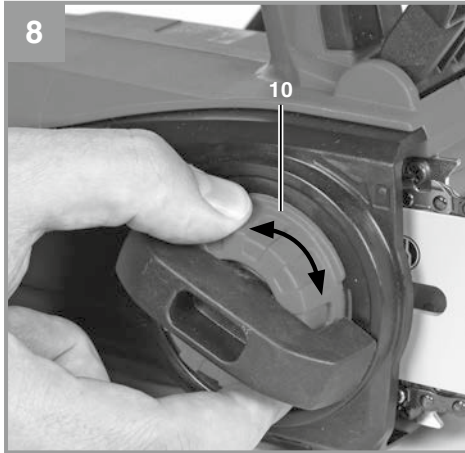

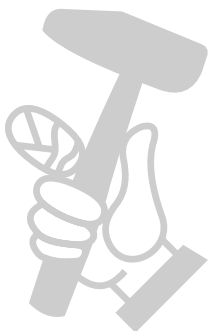
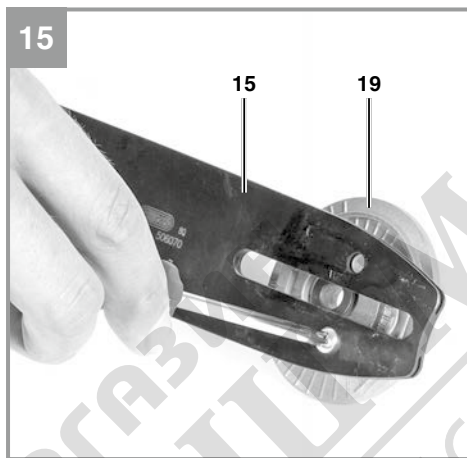
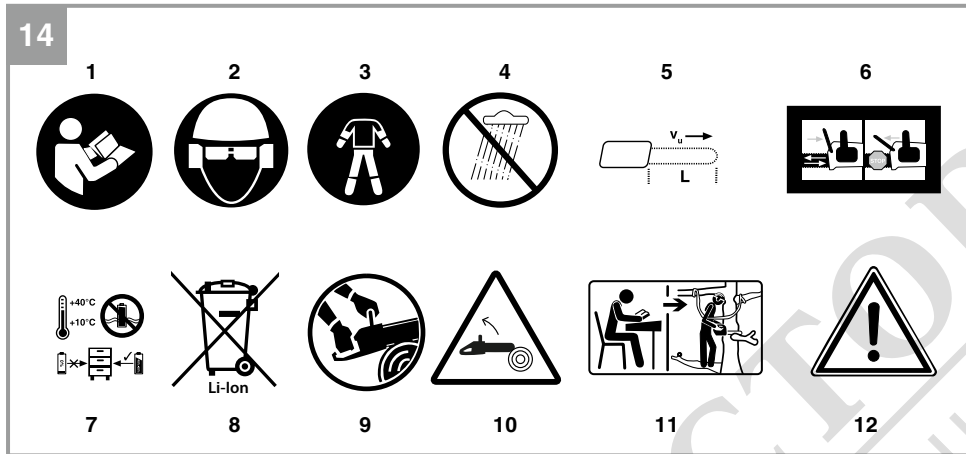

Danger!

When using the equipment, a few safety precautions must be observed to avoid injuries and damage. Please read the complete operating instructions and safety regulations with due care. Keep this manual in a safe place, so that the information is available at all times. If you give the equipment to any other person, hand over these operating instructions and safety regulations as well. We cannot accept any liability for damage or accidents which arise due to a failure to follow these instructions and the safety instructions.

Explanation of the symbols on the equipment (Fig. 14):

1. Read the operating instructions.
2. On all jobs performed with the saw, you must always wear safety goggles to guard your eyes from flying chips/materials/objects and a sound-proof helmet, ear plugs or the like to protect your hearing. Always wear a safety helmet, because there is a risk of objects falling on you from above.
3. The user must wear tight-fitting clothing and protective gear to prevent cuts to the hands, lower arms, legs and feet.
4. Do not expose the device to rain.
5. Maximum cutting length / chain speed
6. Unlock the chain brake before putting into operation!
7. Store the battery only in dry rooms with an ambient temperature of +10°C to +20°C. Place only charged batteries in storage (charged at least 40%).
8. The batteries must be removed from the tool before it is disposed of. How to dispose of batteries: Batteries are not allowed in household waste.
9. Always hold the cordless chainsaw firmly with both hands.
10. Kick-back might result in fatal injuries from cuts.
11. This particular type of power saw is allowed to be used only for tree care by persons who are specially trained.
12. Warning! Danger!

1. Safety regulations

The corresponding safety information can be found in the enclosed booklet.

Warning!

Read all the safety information, instructions, illustrations and technical data provided on or with this power tool. Failure to adhere to the following instructions may result in electric shock, fire and/or serious injury.

Keep all the safety information and instructions in a safe place for future use.

2. Layout and items supplied**2.1 Layout (Fig. 1-3)**

1. Claw stop
2. Front hand guard (chain brake)
3. Front handle
4. Rear handle
5. Safety lock-off
6. On/Off switch
7. Oil tank cap
8. Chain wheel cover
9. Fixing screw for the chain wheel cover
10. Chain tensioning screw
11. Chain oil fill level indicator
12. Battery (in the case of Art. No.: 4600020 it is not included in delivery)
13. Pushlock button
14. Rear hand guard
15. Cutter rail
16. Saw chain
17. Cutter rail guard
18. Charger (in the case of Art. No.: 4600020 it is not included in delivery)
19. Adapter plate
20. Attachment device for sling
21. Chain catch

Safety functions

- 16** The specially developed safety features of the LOW-KICKBACK SAW CHAIN will help you reduce and absorb the force created by a kickback.
- 2** The front hand guard (chain brake) protects the left hand of the operator if it slips off the front handle while the saw is running. The CHAIN BRAKE is a safety function that reduces injuries caused by kickback by stopping a running saw chain in milliseconds. It is activated by the front hand guard (chain brake).

- 6 The ON/OFF SWITCH stops the motor as soon as it is switched off.
- 5 The SAFETY LOCK-OFF prevents the motor being turned on accidentally. The ON/OFF SWITCH can only be pressed if the safety lock-off is also pressed.
- 21 The CHAIN CATCH reduces the risk of injuries if the saw chain breaks or slips while the motor is running. The chain catch is designed to catch a chain that is wrapping around itself.

Note: Familiarize yourself with the saw and its parts.

2.2 Items supplied

Please check that the article is complete as specified in the scope of delivery. If parts are missing, please contact our service center or the sales outlet where you made your purchase at the latest within 5 working days after purchasing the product and upon presentation of a valid bill of purchase. Also, refer to the warranty table in the service information at the end of the operating instructions.

- Open the packaging and take out the equipment with care.
- Remove the packaging material and any packaging and/or transportation braces (if available).
- Check to see if all items are supplied.
- Inspect the equipment and accessories for transport damage.
- If possible, please keep the packaging until the end of the guarantee period.

Danger!

The equipment and packaging material are not toys. Do not let children play with plastic bags, foils or small parts. There is a danger of swallowing or suffocating!

- Original operating instructions
- Safety instructions

3. Proper use

Danger! This chainsaw is a special type of chainsaw intended specifically for tree care. During use, the rear handle should be held in the right hand and the front handle should be held in the left hand. It should only be operated by fully trained users to remove branches and to cut off the tops of standing trees. Persons using the chain-

saw must have read and understood the safety requirements contained in the operating instructions, and they must wear appropriate personal protective equipment (PPE).

The chainsaw must only be operated by persons who are fully trained for this type of chainsaw. The user must be trained in all manual chainsaw work skills. This chainsaw is not intended for use in other types of applications.

The equipment is to be used only for its prescribed purpose. Any other use is deemed to be a case of misuse. The user / operator and not the manufacturer will be liable for any damage or injuries of any kind caused as a result of this.

Please note that our equipment has not been designed for use in commercial, trade or industrial applications. Our warranty will be voided if the machine is used in commercial, trade or industrial businesses or for equivalent purposes.

4. Technical data

Motor power supply: 18 V DC
 Idle speed n_0 : 3800 rpm
 Battery charger output voltage:
 Battery charger output current:
 Charging unit supply voltage:
 Battery type: Li-Ion
 Number of battery cells:
 Battery capacitance:
 Cutter rail length:20 cm
 Max. cutting length: 14 cm
 Cutting speed at rated rpm:7.0 m/s
 Oil tank capacity:75 ml (7.5 cm³)
 Weight approx. 3 kg
 Chain type Oregon Chain: 90PX033X
 Cutter rail type .. 4500194 (Oregon 084LNEA041
 + tip guard)

The cutter rail with article number 4500194 (Einhell) is a modified Oregon model with a tip guard. It is only available as a replacement cutter rail under article number 4500194.

Net weight without chain and guide rail2 kg

Please use only batteries and chargers from the Power-X-Change series, e.g. 1.5Ah and 5.2Ah batteries and the 3A Power-X charger.

Danger!

Sound and vibration

Sound and vibration values were measured in accordance with EN 62841-1 and EN ISO 11681-2.

L_{pA} sound pressure level	84.4 dB(A)
K_{pA} uncertainty	3 dB
L_{WA} sound power level	91.9 dB(A)
K_{WA} uncertainty	3.88 dB
L_{WA} sound power level guaranteed	96 dB(A)

Wear ear-muffs.

The impact of noise can cause damage to hearing.

Total vibration values (vector sum of three directions) were determined in accordance with EN 62841-1 and EN ISO 11681-2.

Handle under load

Vibration emission value front handle

$$a_h = 2.85 \text{ m/s}^2$$

Vibration emission value rear handle

$$a_h = 2.18 \text{ m/s}^2$$

$$K \text{ uncertainty} = 1.5 \text{ m/s}^2$$

The stated vibration emission levels and stated noise emission values were measured in accordance with a set of standardized criteria and can be used to compare one power tool with another.

The stated vibration emission levels and stated noise emission values can also be used to make an initial assessment of exposure.

Warning:

The vibration and noise emission levels may vary from the level specified during actual use, depending on the way in which the power tool is used, especially the type of workpiece it is used for.

Keep the noise emissions and vibrations to a minimum.

- Only use appliances which are in perfect working order.
- Service and clean the appliance regularly.
- Adapt your working style to suit the appliance.
- Do not overload the appliance.

- Have the appliance serviced whenever necessary.
- Switch the appliance off when it is not in use.
- Wear protective gloves.

5. Before starting the equipment

Warning!

Always remove the battery pack before making adjustments to the equipment.

Danger! Do not fit the battery until the chainsaw has been fully assembled and the chain tension has been set. Always wear protective gloves when working on the chainsaw to protect yourself against injury.

5.1 Fitting the cutter rail and saw chain

- Carefully unpack all parts and check that they are complete (Fig. 2-3).
- Undo the fastening screw of the chain wheel cover (9) (Fig. 4).
- Take off the chain wheel cover (8) (Fig. 5).
- Lay the chain (16) as shown in the groove which runs around the cutter rail (15) (Fig. 6a/ Item A).
- Insert the cutter rail and chain as shown into the mounting of the cordless chainsaw. As you do so, guide the chain around the chain wheel (Fig. 6b and 6c/ Item B).
- Attach the chain wheel cover and secure it with the fastening screw (9) (Fig. 7). Important! Do not fully tighten the fastening screw until after you have adjusted the chain tension (see section 5.2).

5.2 Tensioning the saw chain

Warning! Always disconnect the mains plug before performing any checks or adjustments. Always wear protective gloves when working on the chainsaw to protect yourself against injury.

- Undo the fastening screw of the chain wheel cover (9) a few turns (Fig. 4).
- Adjust the chain tension with the chain tensioning screw (Fig. 8/ Item 10). Turning the screw clockwise increases the tension, turning it counter-clockwise decreases the chain tension. The saw chain is correctly tensioned if it can be lifted around 3-4 mm in the middle of the cutter rail (Fig. 9).
- Tighten the fastening screw of the chain wheel cover (9) (Fig. 7).

Danger! All of the chain links must lie proper-

ly in the guide groove of the cutter rail.

Notes on tensioning the chain:

The saw chain must be properly tensioned to ensure safe operation. You can tell that the chain tension is perfect if the saw chain can be lifted by around 3-4 mm in the middle of the cutter rail. As the saw chain heats up during cutting and thus changes in length, please check the chain tension every 10 minutes and adjust it again as required. This applies in particular to new saw chains. When you have finished working slacken the chain again, as the chain will shorten when it cools down. This will prevent the chain from being damaged.

5.3 Saw chain lubrication

Warning! Always pull out the battery before performing any checks or adjustments. Always wear protective gloves when working on the chainsaw to protect yourself against injury.

Notice! Never operate the chain if it is not lubricated with saw chain oil. Use of the chainsaw without saw chain oil or if the oil level is below the "min" mark (Fig. 10/ Item B) will damage the chainsaw.

Notice! Be aware of the temperature conditions: different lubricants with completely different viscosities are required at different ambient temperatures. At lower temperatures you will need low viscosity oils in order to achieve a sufficient lubricating film. However, if the same low viscosity oil is used during the summer it will become even thinner due to the ambient temperatures alone, and as a result the lubricating film could break down, causing the chain to overheat and become damaged. In addition, the chain oil would burn and produce unnecessary pollutants.

Filling the oil tank:

- Keep away from ignition sources.
- Place the chainsaw on a flat surface.
- Clean the area around the oil tank cover (Fig. 10/Item 7) and then clean the oil tank cover.
- Fill the tank with saw chain oil. In the process, make sure that no dirt enters the tank, as this could cause the oil nozzle to become blocked.
- Close the oil tank cover.

5.4 Charging the Li battery pack (Fig. 11-12)

The battery is protected from exhaustive discharge. An integrated protective circuit automatically switches off the equipment when the battery is flat.

Warning! Do not actuate the On/Off switch any more if the protective circuit has tripped. This may damage the battery.

1. Remove the battery pack from the handle, pressing the pushlock button (13) downwards to do so.
2. Check that your mains voltage is the same as that marked on the rating plate of the battery charger. Insert the power plug of the charger (18) into the socket outlet. The green LED will then begin to flash.
3. Push the battery pack onto the battery charger.

In section 12 (Charger indicator) you will find a table with an explanation of the LED indicator on the charger.

If the battery pack fails to charge, check for the following:

- voltage at the power socket
- whether there is good contact at the charging contacts of the charging unit

If the battery pack still fails to charge, send

- the charger and charging adapter
 - and the battery pack
- to our customer service center.

To ensure that items are properly packaged and delivered when you send them to us, please contact our customer service or the point of sale at which the equipment was purchased.

When shipping or disposing of batteries and cordless tools, always ensure that they are packed individually in plastic bags to prevent short circuits and fires.

To ensure that the battery pack provides long service, you should take care to recharge it promptly. You must recharge the battery pack when you notice that the performance of the device drops. Never allow the battery pack to become fully discharged. This will cause it to develop a defect.

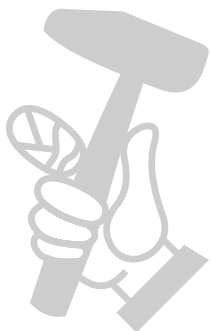

5.5 Battery capacity indicator (Fig. 12)

Press the button for the battery capacity indicator (C). The battery capacity indicator (D9 shows the charge status of the battery using 3 LEDs.

All 3 LEDs are lit:

The battery is fully charged.

2 or 1 LED(s) are lit:

The battery has an adequate remaining charge.

1 LED flashes:

The battery is empty, recharge the battery.

All LEDs blink:

The battery temperature is too low. Remove the battery from the equipment, keep it at room temperature for one day. If the fault reoccurs, this means that the rechargeable battery has undergone exhaustive discharge and is defective. Remove the battery from the equipment. Never use or charge a defective battery.

6. Operation

6.1 Switching on/off

Switching on

- Plug in the battery on the equipment.
- Hold the chainsaw by the handles with both hands as shown in Fig. 13 (thumbs under the handles).
- Press and hold the safety lock-off (Fig. 1/Item 5).
- Switch on the chainsaw at the ON/OFF switch (Fig. 1/Item 6). You can then release the safety lock-off.

Switching off

Release the ON/OFF switch (Fig. 1/Item 6).

The integrated brake will bring the running chainsaw to a standstill within a very short space of time. Always disconnect the mains plug when you stop working, even if it is only for a short time.

Warning! Always carry the saw by the front handle. If the saw is plugged in and you carry it by the rear handle (which is where the switches are located), then there is a risk that you could accidentally press the safety lock-off and the ON/OFF switch at the same time, and the chainsaw could inadvertently start up.

6.2 Safety devices

Motor brake

The motor brakes the saw chain as soon as the ON/OFF switch (Fig. 1/Item 6) is released or the power supply is interrupted. This significantly reduces the risk of injury that would otherwise be present if the chain continued to run after being switched off or disconnected.

Chain brake

The chain brake is a safety mechanism which is triggered via the front hand guard (Fig. 1/Item 2). If kickback causes the chainsaw to suddenly jerk back then the chain brake trips and stops the saw chain in less than 0.1 seconds. You must check the operation of the chain brake on a regular basis. To do this, fold the hand guard (Fig. 1/Item 2) forward and briefly switch the chainsaw on. The saw chain must not start up. Pull back the front hand guard (Fig. 1/Item 2) until it engages to release the chain brake.

Danger! Never use the saw if the safety equipment is not working properly. Never try to repair safety related protection systems yourself – always have any work done by our service department or by a similarly qualified workshop.

Hand guard

The front hand guard (which also acts as the chain brake at the same time) (Fig. 1/Item 2) and the rear hand guard (Fig. 1/Item 14) protect against finger injuries resulting from contact with the saw chain if the chain breaks because it is overloaded.

7. Working with the chainsaw

7.1 Preparations

To ensure that you can work safely, check the following points before every use:

Condition of the chain saw

Inspect the chainsaw before the start of work for damage to the housing, the power cable, the saw chain and the cutter rail. Never use a chainsaw which is obviously damaged.

Oil container

Fill level of the oil container. Even while working, keep checking that sufficient oil is in the system. To avoid damaging the chainsaw, never run the saw if there is no oil in the system or if the oil

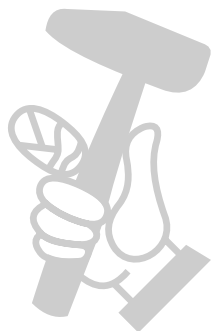

drops below the “min” mark (Fig. 10/Item B). On average, a single filling will last around 15 minutes depending on the number of pauses in cutting and the loads involved.

Saw chain

Tension of the saw chain, condition of the cutting elements. The sharper the chainsaw, the easier and more controllable it is to operate the chainsaw. The same also applies to the chain tension. Again, while working also check the chain tension every 10 minutes in order to increase your safety. New saw chains in particular often tend to expand more.

Chain brake

Check the operation of the chain brake as described in the chapter “Safety devices” and then release it.

8. Cleaning, maintenance and ordering of spare parts

Danger!

- Remove the battery each time before cleaning.
- Never immerse the unit in water or other liquids in order to clean it.

8.1 Cleaning

- Regularly clean the clamping mechanism by blowing it out with compressed air or cleaning it with a brush. Do not use tools for cleaning.
- Keep the handles free of grease so that you can maintain a firm grip.
- Clean the device as required with a damp cloth and, if necessary, mild washing up liquid.
- If the chainsaw is not to be used for an extended period of time then you should remove the chain oil from the tank. Briefly immerse the saw chain and the cutter rail in an oil bath and then wrap them in oil paper.

8.2 Maintenance

Replacing the saw chain and cutter rail

The cutter rail needs to be replaced if

- the guide groove of the cutter rail is worn;
- the nose sprocket in the cutter rail is damaged or worn.

Remove the adapter plate (Item 19) from the cutter rail as shown in Fig. 15. Now fit the adapter

plate to the new cutter rail. Proceed as described in the section “Assembly of the cutter rail and the saw chain”.

Checking the automatic chain lubrication

You should check the operation of the automatic chain lubrication system on a regular basis in order to guard against overheating and the associated damage to the cutter rail and the saw chain. To do this, point the tip of the cutter rail towards a smooth surface (board, section of a cut tree) and allow the chainsaw to run.

If an increasing oil trace becomes evident during this process then the automatic chain lubrication system is working properly. If no clear oil trace is evident then please refer to the corresponding instructions in “Troubleshooting”. If the information contained there still fails to remedy the situation then please contact our service department or another similarly qualified workshop.

Danger! Do not actually touch the surface with the tip of the cutter rail when performing this test. Keep a safe distance (approx. 20 cm).

Sharpening the saw chain

Effective working with the chainsaw is only possible if the saw chain is in good condition and sharp. This also reduces the risk of kickback. The saw chain can be re-sharpened by any dealer. Do not attempt to sharpen the saw chain yourself unless you have the necessary special tools and experience.

8.3 Transport

Engage the chain brake.

To avoid injury, always carry the device with the cutter rail guard fitted. Follow the generally applicable regulations on securing loads.

8.4 Ordering replacement parts:

Please quote the following data when ordering replacement parts:

- Type of machine
- Article number of the machine
- Identification number of the machine
- Replacement part number of the part required

For our latest prices and information please go to www.Einhell-Service.com

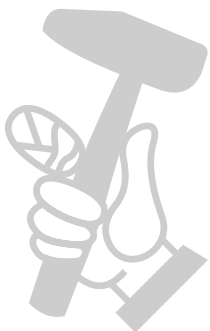

9. Notes on environmental protection / disposal

The equipment is supplied in packaging to prevent it from being damaged in transit. The raw materials in this packaging can be reused or recycled. The equipment and its accessories are made of various types of material, such as metal and plastic. Never place defective equipment in your household refuse. The equipment should be taken to a suitable collection center for proper disposal. If you do not know the whereabouts of such a collection point, you should ask in your local council offices.

10. Storage

Store the equipment and its accessories out of children's reach in a dark and dry place at above freezing temperature. The ideal storage temperature is between +10°C and +20°C. Store the machine in its original packaging. Store the machine with the cutter rail guard fitted, maintained and in a clean state.



For EU countries only

Never place any electric power tools in your household refuse.

To comply with European Directive 2012/19/EC concerning old electric and electronic equipment and its implementation in national laws, old electric power tools have to be separated from other waste and disposed of in an environment-friendly fashion, e.g. by taking to a recycling depot.

Recycling alternative to the return request:
As an alternative to returning the equipment to the manufacturer, the owner of the electrical equipment must make sure that the equipment is properly disposed of if he no longer wants to keep the equipment. The old equipment can be returned to a suitable collection point that will dispose of the equipment in accordance with the national recycling and waste disposal regulations. This does not apply to any accessories or aids without electrical components supplied with the old equipment.

The reprinting or reproduction by any other means, in whole or in part, of documentation and papers accompanying products is permitted only with the express consent of the Einhell Germany AG.

Subject to technical changes

This consignment contains lithium-ion batteries. In accordance with special provision 188 this consignment is not subject to the ADR regulations. Handle with care. Danger of ignition in case of damage to the consignment package. If the consignment package is damaged: Check and if necessary repackage. For further information contact: 0049 9951 95920-66. Outside Germany charges will apply instead for a regular call to a landline number in Germany.

11. Troubleshooting

Danger!

Before troubleshooting, switch off the equipment and pull out the battery.

The table below contains a list of fault symptoms and explains what you can do to remedy the problem if your tool fails to work properly. If the problem still persists after working through the list then please contact your nearest service workshop.

Cause	Fault	Remedy
Chainsaw does not work at all	<ul style="list-style-type: none"> - Quick stop brake has been triggered - No power supply 	<ul style="list-style-type: none"> - Pull the hand protection back to the normal position. - Check the power supply.
Chainsaw operates intermittently	<ul style="list-style-type: none"> - Loose connection (external) - Loose connection (internal) - ON/OFF switch defective 	<ul style="list-style-type: none"> - Consult a specialist workshop. - Consult a specialist workshop. - Consult a specialist workshop.
Saw chain dry	<ul style="list-style-type: none"> - No oil in the tank - Oil tank cap breather blocked - Oil outlet blocked 	<ul style="list-style-type: none"> - Fill up with oil. - Clean the oil tank cap. - Clear the oil outlet.
Chain brake does not work	<ul style="list-style-type: none"> - Problem with the switch mechanism in the front hand guard 	<ul style="list-style-type: none"> - Consult a specialist workshop.
Chain/guide rail hot	<ul style="list-style-type: none"> - No oil in the tank - Oil tank cap breather blocked - Oil outlet blocked - Blunt chain 	<ul style="list-style-type: none"> - Fill up with oil. - Clean the oil tank cap. - Clear the oil outlet - Re-sharpen or replace the chain.
Chainsaw juddering, vibrating or not sawing properly	<ul style="list-style-type: none"> - Chain tension too loose - Blunt chain - Worn chain - Saw teeth pointing in the wrong direction 	<ul style="list-style-type: none"> - Adjust the chain tension. - Re-sharpen or replace the chain. - Replace the chain. - Reinstall the saw chain with the teeth facing in the correct direction.

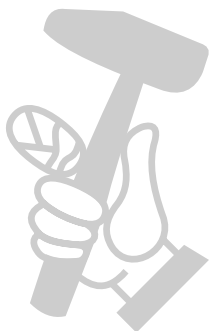

12. Charger indicator

Indicator status		Explanations and actions
Red LED	Green LED	
Off	Flashing	<p>Ready for use The charger is connected to the mains and is ready for use; there is no battery pack in the charger</p>
On	Off	<p>Charging The charger is charging the battery pack in quick charge mode. The charging times are shown directly on the charger. Important! The actual charging times may vary slightly from the stated charging times depending on the existing battery charge.</p>
Off	On	<p>The battery is charged and ready for use. (READY TO GO) The unit then changes over to gentle charging mode until the battery is fully charged. To do this, leave the rechargeable battery on the charger for approx. 15 minutes longer. Action: Take the battery pack out of the charger. Disconnect the charger from the mains supply.</p>
Flashing	Off	<p>Adapted charging The charger is in gentle charging mode. For safety reasons the charging is performed less quickly and takes more time. The reasons can be: - The rechargeable battery has not been used for a very long time. - The battery temperature is outside the ideal range. Action: Wait for the charging to be completed; you can still continue to charge the battery pack.</p>
Flashing	Flashing	<p>Fault Charging is no longer possible. The battery pack is defective. Action: Never charge a defective battery pack. Take the battery pack out of the charger.</p>
On	On	<p>Temperature fault The battery pack is too hot (e.g. due to direct sunshine) or too cold (below 0° C). Action: Remove the battery pack and keep it at room temperature (approx. 20° C) for one day .</p>

Service information

We have competent service partners in all countries named on the guarantee certificate whose contact details can also be found on the guarantee certificate. These partners will help you with all service requests such as repairs, spare and wearing part orders or the purchase of consumables.

Please note that the following parts of this product are subject to normal or natural wear and that the following parts are therefore also required for use as consumables.

Category	Example
Wear parts*	Cutter bar, Battery
Consumables*	Saw chain
Missing parts	

* Not necessarily included in the scope of delivery!

In the effect of defects or faults, please register the problem on the internet at www.Einhell-Service.com. Please ensure that you provide a precise description of the problem and answer the following questions in all cases:

- Did the equipment work at all or was it defective from the beginning?
- Did you notice anything (symptom or defect) prior to the failure?
- What malfunction does the equipment have in your opinion (main symptom)? Describe this malfunction.

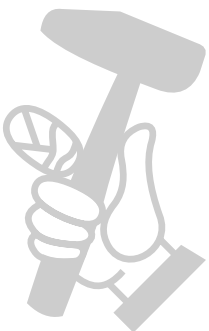

Warranty certificate

Dear Customer,

All of our products undergo strict quality checks to ensure that they reach you in perfect condition. In the unlikely event that your device develops a fault, please contact our service department at the address shown on this guarantee card. You can also contact us by telephone using the service number shown. Please note the following terms under which guarantee claims can be made:

1. These guarantee terms apply to consumers only, i.e. natural persons intending to use this product neither for their commercial activities nor for any other self-employed activities. These warranty terms regulate additional warranty services, which the manufacturer mentioned below promises to buyers of its new products in addition to their statutory rights of guarantee. Your statutory guarantee claims are not affected by this guarantee. Our guarantee is free of charge to you.
2. The warranty services cover only defects due to material or manufacturing faults on a product which you have bought from the manufacturer mentioned below and are limited to either the rectification of said defects on the product or the replacement of the product, whichever we prefer.
Please note that our devices are not designed for use in commercial, trade or professional applications. A guarantee contract will not be created if the device has been used by commercial, trade or industrial business or has been exposed to similar stresses during the guarantee period.
3. The following are not covered by our guarantee:
 - Damage to the device caused by a failure to follow the assembly instructions or due to incorrect installation, a failure to follow the operating instructions (for example connecting it to an incorrect mains voltage or current type) or a failure to follow the maintenance and safety instructions or by exposing the device to abnormal environmental conditions or by lack of care and maintenance.
 - Damage to the device caused by abuse or incorrect use (for example overloading the device or the use of unapproved tools or accessories), ingress of foreign bodies into the device (such as sand, stones or dust, transport damage), the use of force or damage caused by external forces (for example by dropping it).
 - Damage to the device or parts of the device caused by normal or natural wear or tear or by normal use of the device.
4. The guarantee is valid for a period of 24 months starting from the purchase date of the device. Guarantee claims should be submitted before the end of the guarantee period within two weeks of the defect being noticed. No guarantee claims will be accepted after the end of the guarantee period. The original guarantee period remains applicable to the device even if repairs are carried out or parts are replaced. In such cases, the work performed or parts fitted will not result in an extension of the guarantee period, and no new guarantee will become active for the work performed or parts fitted. This also applies if an on-site service is used.
5. To make a claim under the guarantee, please register the defective device at: www.Einhell-Service.com. Please keep your bill of purchase or other proof of purchase for the new device. Devices that are returned without proof of purchase or without a rating plate shall not be covered by the guarantee, because appropriate identification will not be possible. If the defect is covered by our guarantee, then the item in question will either be repaired immediately and returned to you or we will send you a new replacement.

Of course, we are also happy offer a chargeable repair service for any defects which are not covered by the scope of this guarantee or for units which are no longer covered. To take advantage of this service, please send the device to our service address.

Also refer to the restrictions of this warranty concerning wear parts, consumables and missing parts as set out in the service information in these operating instructions.

