



GE-PP 5555 RB-A

- D** Originalbetriebsanleitung
Tauchdruckpumpe
- GB** Original operating instructions
Submersible pressure pump
- F** Instructions d'origine
Pompe refoulante submersible
- I** Istruzioni per l'uso originali
Pompa premente ad immersione
- DK/** Original betjeningsvejledning
N Dyktrykpumpe
- S** Original-bruksanvisning
Dränkbar tryckpump
- CZ** Originální návod k obsluze
Ponorné tlakové čerpadlo
- SK** Originálny návod na obsluhu
Ponorné tlakové čerpadlo
- NL** Originele handleiding
Dompeldruk pomp
- E** Manual de instrucciones original
Bomba sumergible a presión
- FIN** Alkuperäiskäyttöohje
Uppopainepumppu
- H** Eredeti használati utasítás
Bemerülő nyomásszivattyú



Art.-Nr.: 41.704.25

I.-Nr.: 11019



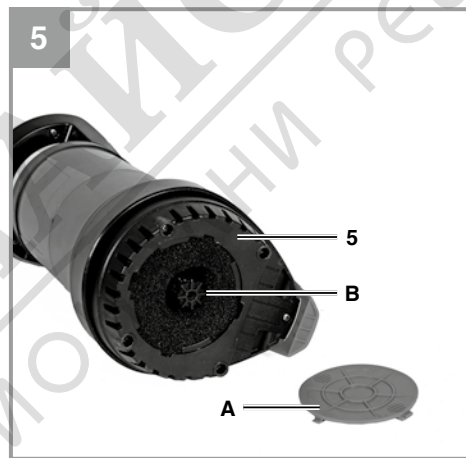
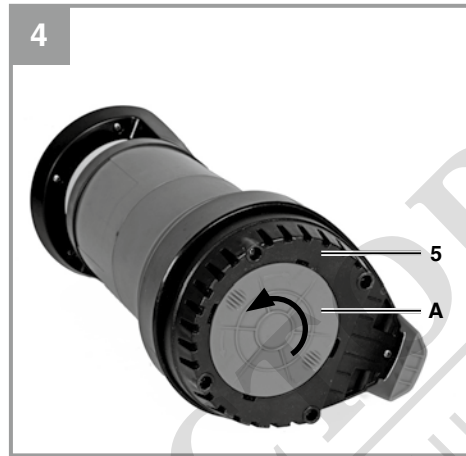
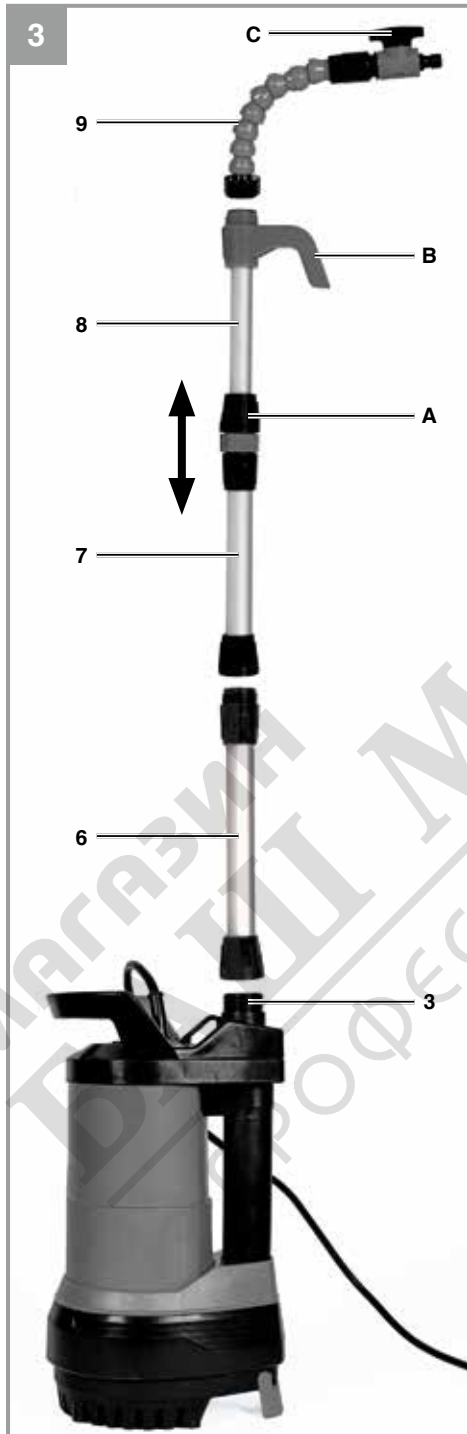



Danger! - Read the operating instructions to reduce the risk of injury

МАГАЗИН МАЙСТОРА®
БАШ ПРОФЕСИОНАЛНИ РЕШЕНИЯ

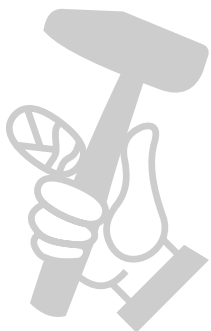

This equipment can be used by children of 8 years and older and by people with limited physical, sensory or mental capacities or those with no experience and knowledge if they are supervised or have received instruction in how to use the equipment safely and understand the dangers which result from such use. Children are not allowed to play with the equipment. Unless supervised, children are not allowed to clean the equipment and carry out user-level maintenance work.

Danger!

When using the equipment, a few safety precautions must be observed to avoid injuries and damage. Please read the complete operating instructions and safety regulations with due care. Keep this manual in a safe place, so that the information is available at all times. If you give the equipment to any other person, hand over these operating instructions and safety regulations as well. We cannot accept any liability for damage or accidents which arise due to a failure to follow these instructions and the safety instructions.

1. Safety regulations**Danger!****Read all safety regulations and instructions.**

Any errors made in following the safety regulations and instructions may result in an electric shock, fire and/or serious injury.

Keep all safety regulations and instructions in a safe place for future use.

Danger!

The pump must be powered via an earth-leakage circuit breaker (RCD) with a rated fault current of no more than 30 mA (according to VDE 0100 Part 702 and 738).

The equipment is not designed for use in swimming pools and paddling pools of any kind or other bodies of water in which people or animals may be present during operation. It is prohibited to operate the equipment if a person or animal is in the danger area. Ask your electrician!

Danger!

- Before you put the equipment into operation, arrange for a specialist to check that the earthing, protective multiple earthing or residual-current operated circuit-breaker circuit comply with the safety regulations of the power supply company and work correctly.
- The electrical plug-in connections must be protected from wet conditions.
- If there is a risk of flooding, place the plug-in connections in an area which is safe from flooding.
- Strictly avoid pumping aggressive liquids and abrasive substances.
- Protect the equipment from frost.
- Protect the equipment from dry running.

- Take suitable measures to keep the equipment out of the reach of children.

2. Layout and items supplied**2.1 Layout (Figs. 1 and 2)**

1. Handle
2. Suspension eye
3. Hose connection
4. Integrated cable rewind
5. Intake cage
6. Extension pipe long
7. Extension pipe short
8. Telescopic pipe with attachment hook
9. Swiveling connection with stopcock

2.2 Items supplied

Please check that the article is complete as specified in the scope of delivery. If parts are missing, please contact our service center or the sales outlet where you made your purchase at the latest within 5 working days after purchasing the product and upon presentation of a valid bill of purchase. Also, refer to the warranty table in the service information at the end of the operating instructions.

- Open the packaging and take out the equipment with care.
- Remove the packaging material and any packaging and/or transportation braces (if available).
- Check to see if all items are supplied.
- Inspect the equipment and accessories for transport damage.
- If possible, please keep the packaging until the end of the guarantee period.

Danger!

The equipment and packaging material are not toys. Do not let children play with plastic bags, foils or small parts. There is a danger of swallowing or suffocating!

- Submersible pressure pump
- Pipe set
- Original operating instructions

3. Proper use

The equipment you have purchased is designed to pump water with a maximum temperature of 35 °C. This equipment must never be used for other liquids, especially not for engine fuels, cleaning agents and other chemically-based products!

The equipment can be used wherever you want to move water, e.g. in the house, in the garden, and for many other applications. It must not be used to operate swimming pools!

If you want to use the equipment in bodies of water with a natural, muddy bottom, place the equipment in a slightly elevated position, e.g. on bricks.

The equipment is not designed for continuous operation, e.g. as a circulating pump in a pond. In this case the equipment's anticipated life will be greatly shortened because the equipment was not designed for continuous loading.

The equipment is to be used only for its prescribed purpose. Any other use is deemed to be a case of misuse. The user / operator and not the manufacturer will be liable for any damage or injuries of any kind caused as a result of this.

Please note that our equipment has not been designed for use in commercial, trade or industrial applications. Our warranty will be voided if the machine is used in commercial, trade or industrial businesses or for equivalent purposes.

The water may be contaminated by escaping lubricating oil/lubricant.

4. Technical data

Mains connection	230-240 V ~ 50 Hz
Power consumption	550 W
Pumping rate max.	5500 l/h
Delivery head max.	20 m
Delivery pressure max.	0.20 MPa (2.0 bar)
Immersion depth max.	7 m
Water temperature max.	35 °C
Hose connection	approx. 33.3 mm (1") AG
Foreign body size max.:	Clean water
Suction height min. approx.	5 mm
Minimum water level upon starting	50 mm
Cut-in pressure at	approx. 0.12 Mpa (1.2 bar)
Protection type:	IPX8

Using the pump with the pipe set

Pumping rate max.	2300 l/h
Delivery head max.	20 m
Delivery pressure	max. 0.20 MPa (2.0 bar)

5. Before starting the equipment

Before you connect the equipment to the mains supply make sure that the data on the rating plate are identical to the mains data.

5.1 Installation

The equipment can be installed either:

- Stationary with a rigid pipe line or
- Stationary with a flexible hose line

Notice!

Before you use the pump, clarify any possible special conditions which need to be fulfilled for the installation!

For example, additional safety measures may be needed if damage to property could result from a power failure, soiling or a defective gasket.

Examples of such safety measures:

Pumps running in parallel on a separately protected power circuit, moisture sensors for switching off the pumps, and similar safety arrangements.

Be sure to consult a professional plumber if you have any doubt.

The maximum pumping rate is possible only with the largest possible line diameter; if smaller hoses or pipes are connected, the pumping rate will be reduced.

Venting:

Water might escape from the vent opening during operation.

Please note!

When installing, never hang the equipment by the discharge line or by the power cable. The equipment must be hung up by the provided carry handle or suspension eyelet, or it must rest on the bottom of the shaft. To ensure that the equipment works properly, the bottom of the shaft always must be free of sludge and other accumulations of dirt. If the water level is too low, the sludge in the shaft can quickly dry out and hinder the equipment from starting. It is necessary therefore to check the equipment regularly (carry out trial start-ups).

The pump shaft should be large enough.

5.2 Using the pump in the rain barrel

Fit the supplied pipe set as described and make sure that the seals between the individual components are correctly seated (Fig. 3):

1. Connect the telescopic pipe (8) to the short extension pipe (7).
2. Screw the complete telescopic pipe to the longer extension pipe (6) and to the swiveling connection (9).

Proceed as follows to use the pump in the rain barrel:

- Connect the pipe set to the pump.
- Use the attachment hook (Fig. 3 / Item B) to hang the pump in the rain barrel. To vary the height, undo the clamp lever of the telescopic pipe (Fig. 3 / Item A) and tighten it again when the desired position is reached. You should set the length of the telescopic pipe such that the pump does not touch the bottom. This will keep dirt away from the pump.
- The height of the attachment hook can be adjusted to between 63 and 108 mm depending on whether the extension pipe is used or not.
- If necessary, use a hose to extend the telescopic pipe.
- To withdraw water, open the stopcock (Fig. 3 / Item C).

5.3 Mains connection**Danger!**

The equipment you have purchased comes with an earthing-pin plug. The equipment is designed for connection to a socket outlet with earthing

contact for 230-240 V ~ 50 Hz. Make sure that the socket-outlet is sufficiently fused (at least 6 A) and in good working order. Insert the power plug in the socket-outlet and the equipment is ready for operation.

6. Operation

You can put the equipment into operation after you have thoroughly read the installation and operating instructions. Pay attention to the following points:

- Make sure that the equipment is set up securely.
- Check that the discharge line is fitted correctly.
- Make sure that the electrical connection is 230-240 V ~ 50 Hz.
- Check that the electrical socket-outlet is in good working order.
- Make sure that no moisture or water can ever reach the power connection.
- Make sure that the equipment does not run dry.
- To switch off the equipment, pull the power plug out of the socket outlet.

Note!

1. Lower the pump into the well or shaft or hang it in the rain barrel using a securing cable.
2. Connect the mains plug to the socket.

The pump will start immediately after the connection cable is plugged in.

6.1 Automatic mode:

The pump builds up pressure (e.g. a water tap is closed) and then switches off automatically. The integrated non-return valve ensures that the pressure is maintained in the hose until water is drawn off again. When the pressure drops below 1.2 bar, the pump will switch on again automatically.

6.2 Dry-run safeguard:

The pump will make up to 3 priming attempts if:

- the pump is started by inserting the mains plug into the power socket
- or
- medium ceases to be available during operation.

If the availability of medium ceases, the pump will go automatically into dry-run safeguard mode

and switch off. The pump has to be disconnected and reconnected at the power socket in order to become ready for operation again.

7. Replacing the power cable

Danger!

If the power cable for this equipment is damaged, it must be replaced by the manufacturer or its after-sales service or similarly trained personnel to avoid danger.

8. Cleaning, maintenance and ordering of spare parts

Danger!

- Unplug the power plug prior to any maintenance work.
- For mobile applications, the equipment should be cleaned with clear water after every usage.
- Use a water jet to remove any lint or fibrous particles that may have become trapped in the housing.
- Remove sludge from the shaft bottom and clean the shaft walls every 3 months.

8.1 Cleaning the filter (Figs. 4 and 5)

In order to protect the equipment and the impeller from severe soiling, an additional filter has been installed in the bottom intake cage. Please proceed as follows when cleaning the filter:

1. Open the filter cover (A) in the intake cage (5).
2. Remove the filter (B) and wash it out under running water.
3. Assemble in reverse order.

8.2 Maintenance

There are no parts inside the equipment which require additional maintenance.

8.3 Ordering replacement parts:

Please quote the following data when ordering replacement parts:

- Type of machine
- Article number of the machine
- Identification number of the machine
- Replacement part number of the part required

For our latest prices and information please go to www.Einhell-Service.com

9. Disposal and recycling

The equipment is supplied in packaging to prevent it from being damaged in transit. The raw materials in this packaging can be reused or recycled. The equipment and its accessories are made of various types of material, such as metal and plastic. Never place defective equipment in your household refuse. The equipment should be taken to a suitable collection center for proper disposal. If you do not know the whereabouts of such a collection point, you should ask in your local council offices.

10. Storage

Store the equipment and accessories in a dark and dry place at above freezing temperature. The ideal storage temperature is between 5 and 30 °C. Store the electric tool in its original packaging.

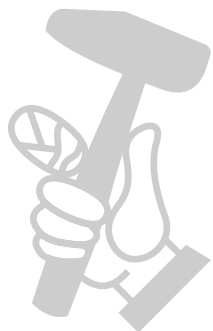

11. Troubleshooting guide

Faults	Cause	Remedy
The equipment does not start	- Power supply not connected	- Check power supply
The equipment does not pump	- Intake sieve clogged - Discharge hose kinked	- Clean intake sieve with water jet - Unkink the hose
Insufficient pumping rate	- Intake sieve clogged - Performance reduced due to heavily contaminated and abrasive water impurities	- Clean intake sieve - Clean equipment and replace wear parts
The equipment switches off after briefly running	- Motor circuit-breaker switches the equipment off due to excessive water contamination - Water temperature too high; motor circuit-breaker switches the equipment off	- Unplug power plug and clean equipment and shaft - Ensure that maximum permissible water temperature (35 °C) is not exceeded

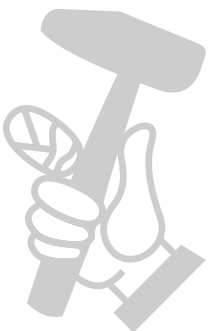

Disposal

Power tools, rechargeable batteries, accessories and packaging should be sorted for environmental-friendly recycling.

Do not dispose of power tools and batteries/rechargeable batteries into household waste!

Only for EU countries:

According to the Directive 2012/19/EU on waste electrical and electronic equipment and its transposition into national law, power tools that are no longer usable, and, according to the Directive 2006/66/EC, defective or drained batteries must be collected separately and disposed of in an environmentally correct manner.

If disposed incorrectly, waste electrical and electronic equipment may have harmful effects on the environment and human health, due to the potential presence of hazardous substances.

Only for United Kingdom:

According to The Waste Electrical and Electronic Equipment Regulations 2013 (SI 2013/3113) (as amended) and the Waste Batteries and Accumulators Regulations 2009 (SI 2009/890) (as amended), products that are no longer usable must be collected separately and disposed of in an environmentally friendly manner.

The reprinting or reproduction by any other means, in whole or in part, of documentation and papers accompanying products is permitted only with the express consent of the Einhell Germany AG.

Subject to technical changes

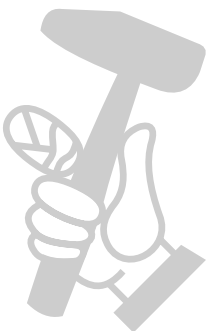

Service information

We have competent service partners in all countries named on the guarantee certificate whose contact details can also be found on the guarantee certificate. These partners will help you with all service requests such as repairs, spare and wearing part orders or the purchase of consumables.

Please note that the following parts of this product are subject to normal or natural wear and that the following parts are therefore also required for use as consumables.

Category	Example
Wear parts*	Impeller
Consumables*	
Missing parts	

* Not necessarily included in the scope of delivery!

In the effect of defects or faults, please register the problem on the internet at www.Einhell-Service.com. Please ensure that you provide a precise description of the problem and answer the following questions in all cases:

- Did the equipment work at all or was it defective from the beginning?
- Did you notice anything (symptom or defect) prior to the failure?
- What malfunction does the equipment have in your opinion (main symptom)? Describe this malfunction.



Warranty certificate

Dear Customer,

All of our products undergo strict quality checks to ensure that they reach you in perfect condition. In the unlikely event that this equipment develops a fault, please contact our service department at the address shown on this guarantee card. You can also contact us by telephone using the service number shown. Please note the following terms under which guarantee claims can be made:

1. These guarantee terms apply solely to consumers, i.e. natural persons, who do not want to use this product in connection with either their commercial or other self-employed activities. These guarantee terms regulate additional guarantee services which the undermentioned manufacturer promises to buyers of its new products in addition to their statutory rights of guarantee. Your statutory rights of guarantee are not affected by this guarantee. Our guarantee is free of charge to you.
2. The guarantee services cover only defects due to material or manufacturing faults on the new product which you have bought in the European Union from the undermentioned manufacturer and are limited to either the rectification of said defects or the replacement of the product, whichever we prefer. Please note that only equipment under the brand name "Professional" has been designed for use in commercial, trade or professional applications. For all other products the guarantee is invalidated if the equipment is used within the guarantee period in commercial, trade or industrial applications or for other equivalent activities.
3. Our guarantee does not cover:
 - Damage to the equipment caused by failure to comply with the installation/assembly instructions or by unprofessional installation; damage caused by failure to comply with the operating instructions (e.g. connection to the wrong mains voltage or current type); damage caused by failure to comply with the maintenance and safety regulations; damage caused by exposing the equipment to abnormal environmental conditions; damage resulting from poor care and maintenance.
 - Damage to the equipment caused by misuse or incorrect applications (e.g. overloading the equipment or using non-approved attachments or accessories); damage caused by foreign bodies (e.g. sand, stones, dust, ...) getting inside the equipment. Damage in transit; damage caused by force or external influences (e.g. by dropping the equipment).
 - Damage to the equipment or parts of the equipment which is owed to use-related, normal or otherwise natural wear. For example, batteries and battery packs are manufactured with a cycle limit for design-related reasons. Wear is negatively influenced in particular by load demands and charging speeds as well as exposure to heat, cold, vibration and impact.
4. The guarantee is valid for a period of 2 years starting from the purchase date of the equipment. Guarantee claims must be submitted before the end of the guarantee period and within two weeks of the defect being noticed. No guarantee claims will be accepted after the end of the guarantee period. The original guarantee period remains applicable to the equipment even if repairs are carried out or parts are replaced. In such cases, the work performed or parts fitted will not result in an extension of the guarantee period, and no new guarantee will become active for the work performed or for any replacement parts fitted. This also applies if on-site service is used.
5. To assert your guarantee claim, register the defective equipment at: www.Einhell-Service.com. You will need to provide proof of purchase of the new item of equipment. Equipment returned without such proof or without a rating plate are excluded from the guarantee services because of the lack of traceability. If the defect is covered by our guarantee, then either the item in question will be repaired immediately and returned to you or we will send you a new replacement.
6. If you have taken the equipment with you to a different EU country than where you bought it, we will arrange for a local service partner to provide the guarantee services. If you take the equipment outside the EU, the guarantee will not apply.

Of course, we are also happy to offer a chargeable repair service for any defects which are not covered or no longer covered by the scope of this guarantee. To take advantage of this service, please send the equipment to our service address. We draw attention to the restrictions of this guarantee concerning wear parts, consumables and missing parts as presented in the service information included in this operating manual.

Warrantor/ Service:

Einhell UK Ltd, Unit 10, 1st Floor, Champion's Business Park, Arrowe Brook Road, Upton, Wirral, CH49 0UQ