

<b>D</b>	<b>Originalbetriebsanleitung</b> Zug-, Kapp- und Gehrungssäge	<b>SLO</b>	<b>Originalna navodila za uporabo</b> Dvoročna žaga, čelilna žaga in zajeralna žaga
<b>GB</b>	<b>Original operating instructions</b> Drag, crosscut and miter saw	<b>H</b>	<b>Eredeti használati utasítás</b> Vonó-, fejező- és sarkaló fűrész
<b>F</b>	<b>Instructions d'origine</b> Scie à onglet radiale	<b>RO</b>	<b>Instrucțiuni de utilizare originale</b> Ferăstrău joagăr, de rețezat și îmbinat la colț
<b>I</b>	<b>Istruzioni per l'uso originali</b> Sega a trazione per troncature e tagli obliqui	<b>GR</b>	<b>Πρωτότυπες Οδηγίες χρήσης</b> Φαλτσοπρίονο και πριόνι κάθετης κοπής
<b>DK/</b> <b>N</b>	<b>Original betjeningsvejledning</b> Skør-, kap- og geringssav	<b>P</b>	<b>Manual de instruções original</b> Serra de tração, corte transversal e meia-esquadria
<b>S</b>	<b>Original-bruksanvisning</b> Drag-, kap- och geringssåg	<b>HR/</b> <b>BIH</b>	<b>Originalne upute za uporabu</b> Ručna kružna pila za prorezivanje i koso rezanje
<b>CZ</b>	<b>Originální návod k obsluze</b> Kapovací a pokosová pila s pojezdem	<b>RS</b>	<b>Originalna uputstva za upotrebu</b> Ručna kružna testera za prerezivanje i koso rezanje
<b>SK</b>	<b>Originálny návod na obsluhu</b> Tesárska, kapovacia a pokosová píla	<b>PL</b>	<b>Instrukcja oryginalną</b> Piła ukośna
<b>NL</b>	<b>Originele handleiding</b> Trek-, afkort- en verstekzaag	<b>TR</b>	<b>Orijinal Kullanma Talimatı</b> Gönye kesme
<b>E</b>	<b>Manual de instrucciones original</b> Sierra de tracción, oscilante y para cortar ingletes	<b>EE</b>	<b>Originaalkasutusjuhend</b> Nurga- ja järkamissaag
<b>FIN</b>	<b>Alkuperäiskäyttöohje</b> Veto-, katkaisu- ja jiirisaha		

13



Art.-Nr.: 43.003.80

I.-Nr.: 21022

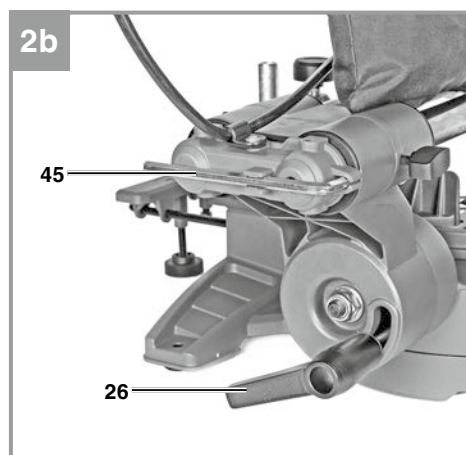
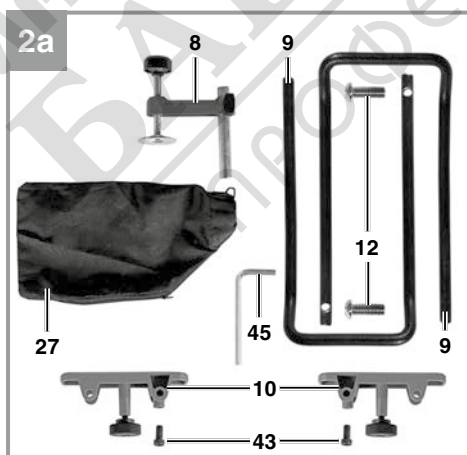
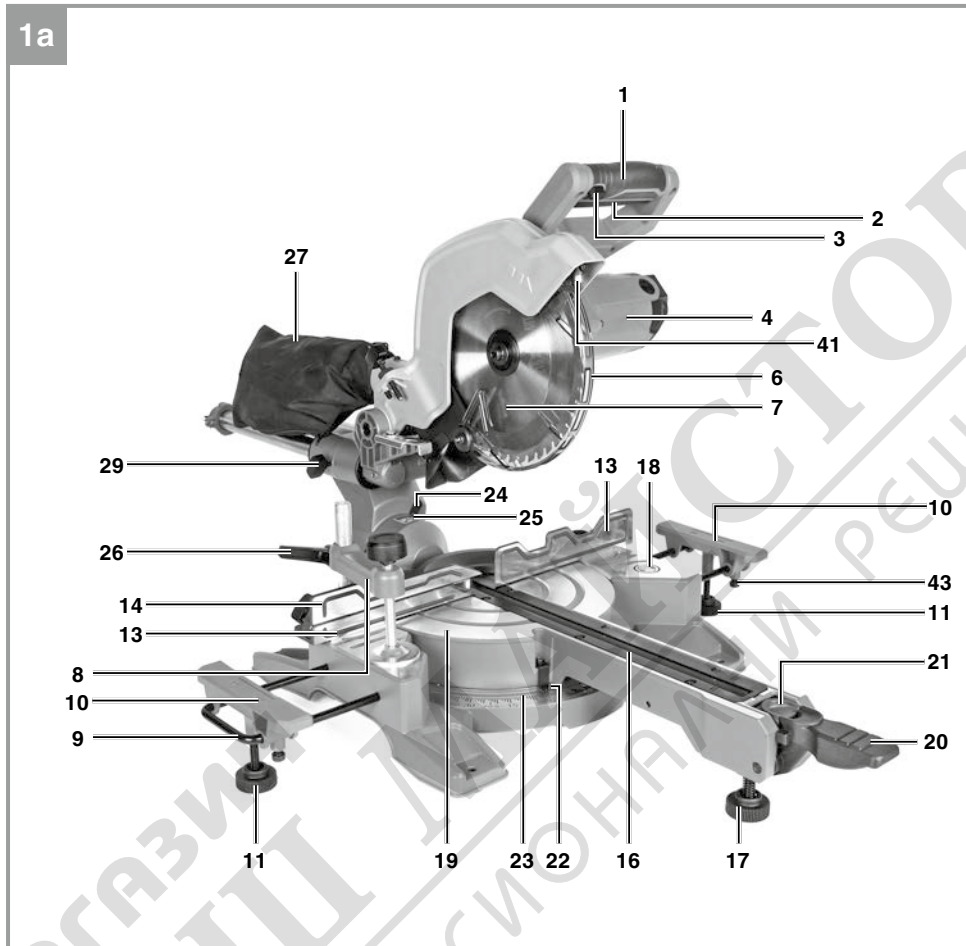

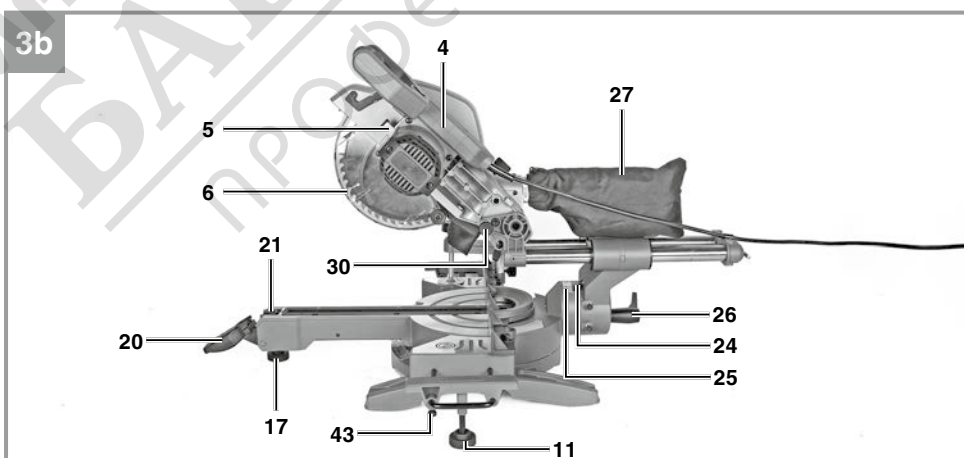
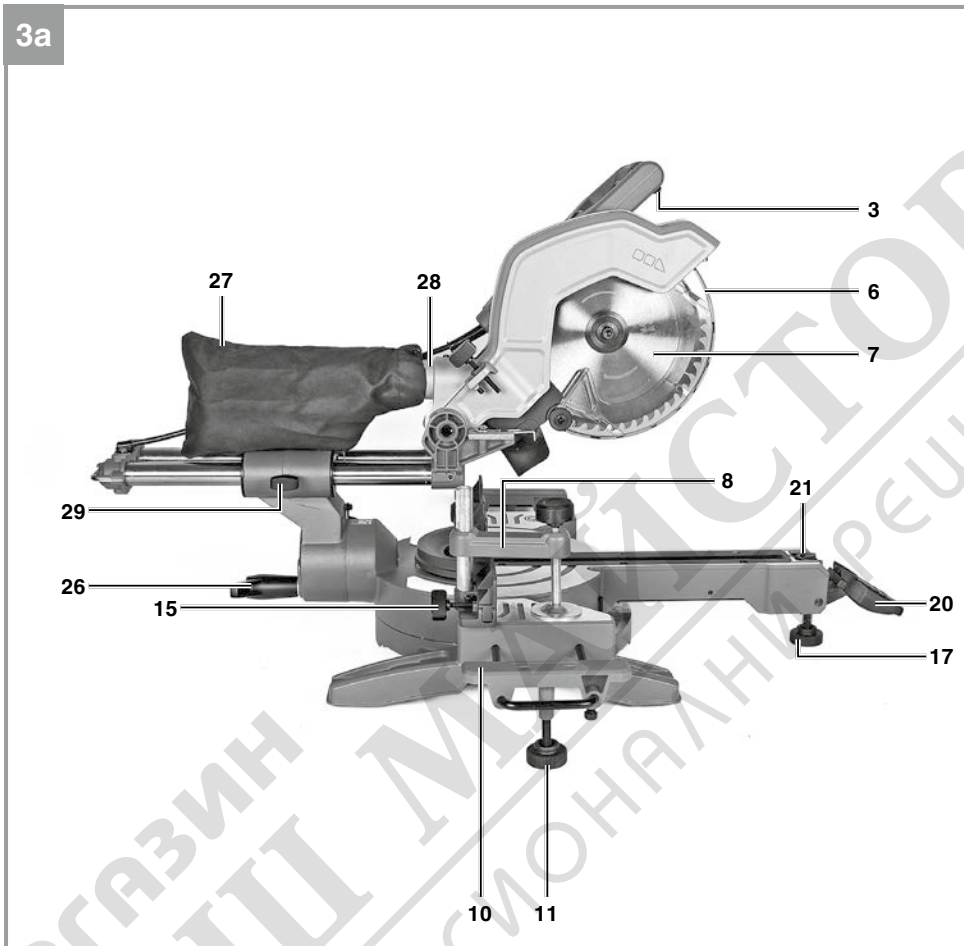

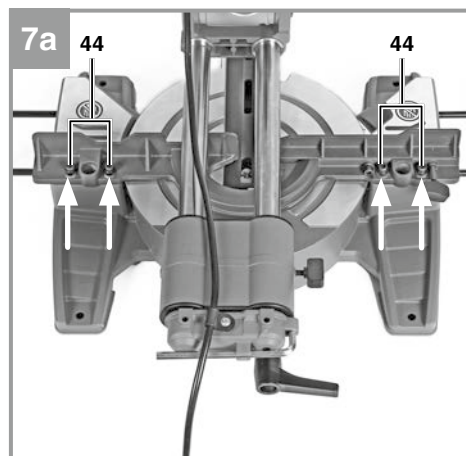
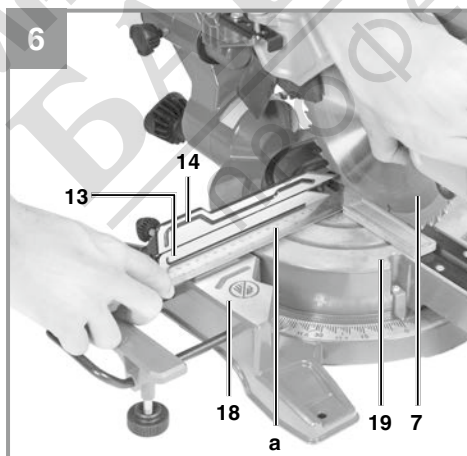
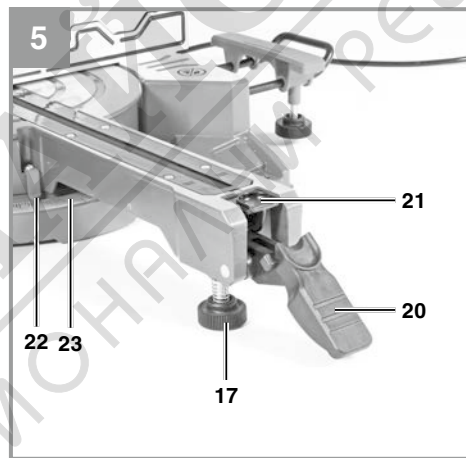
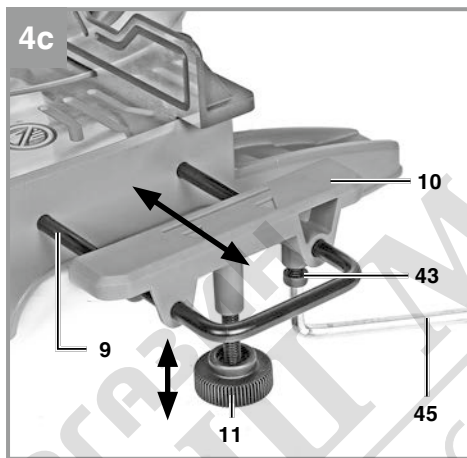
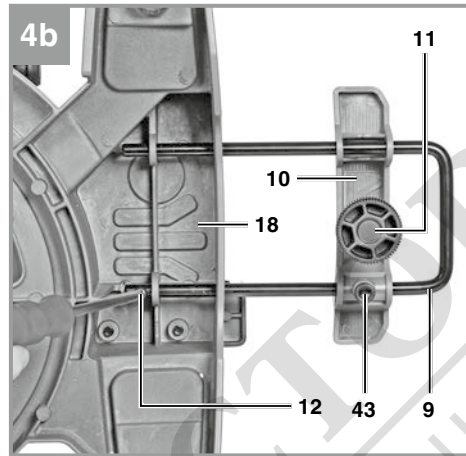
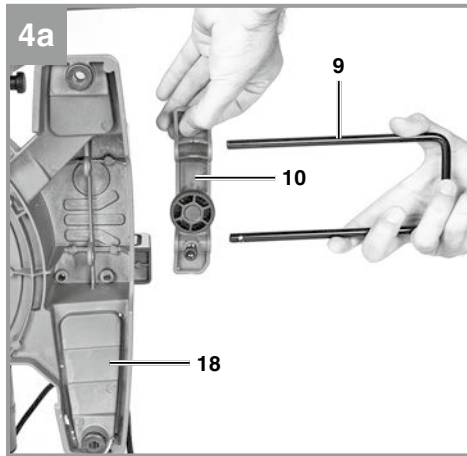

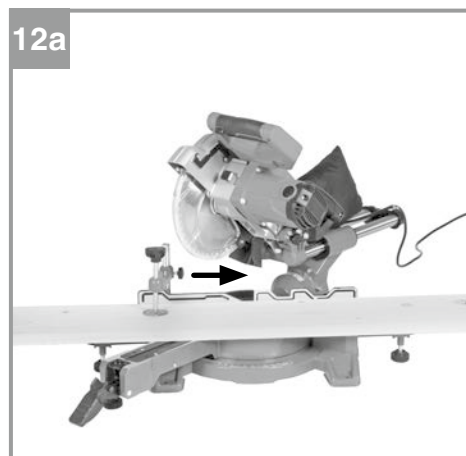
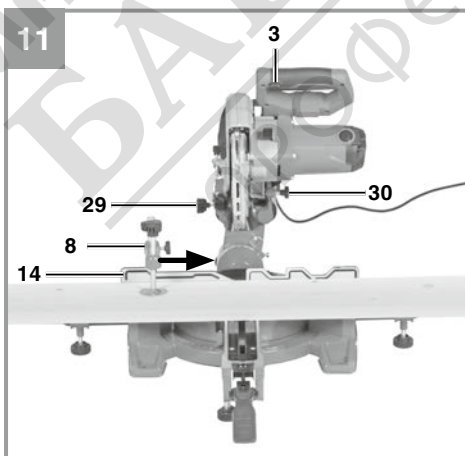
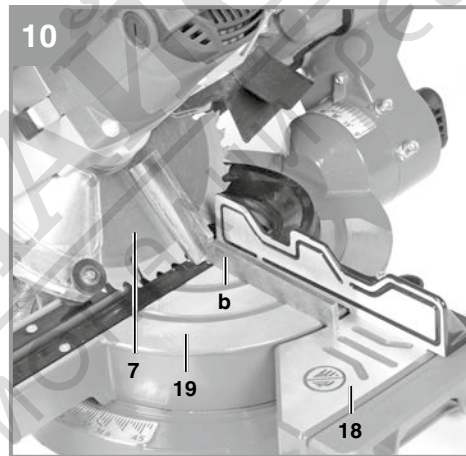
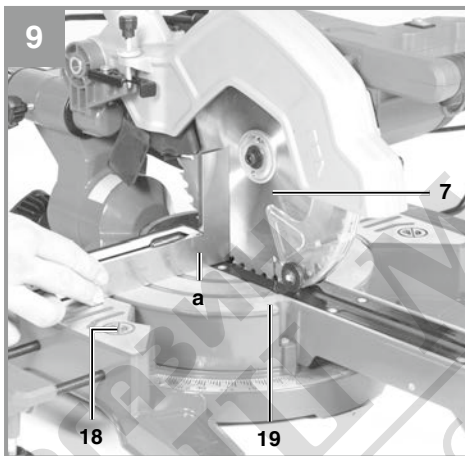
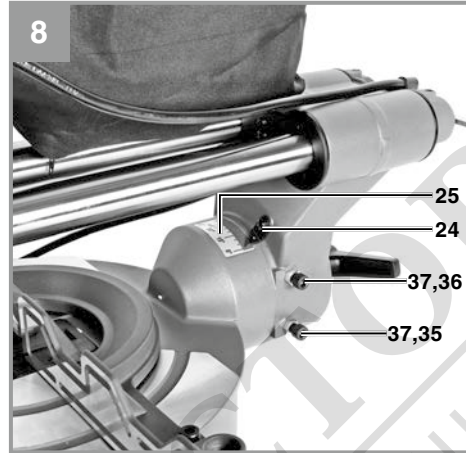
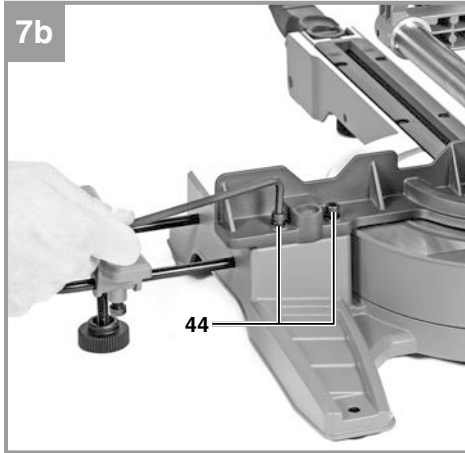

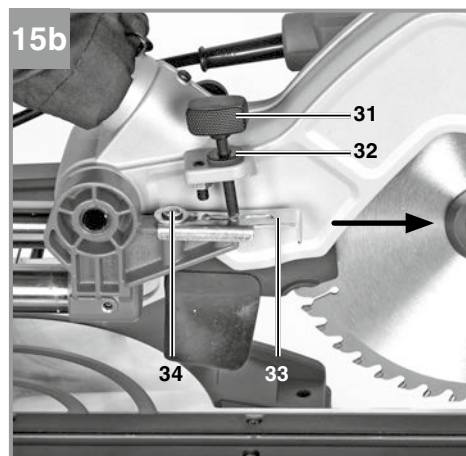
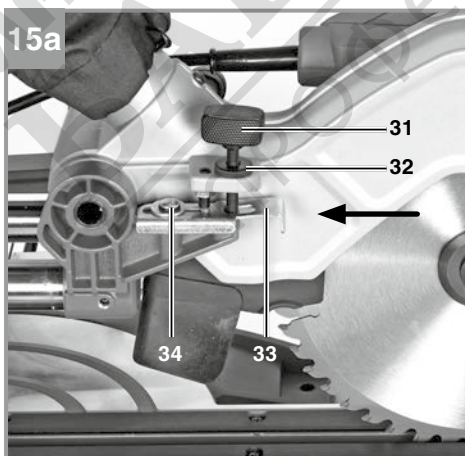
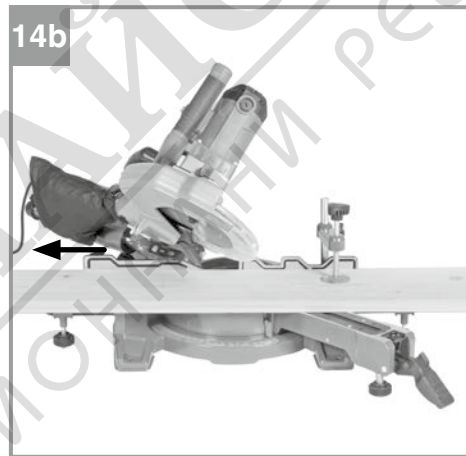
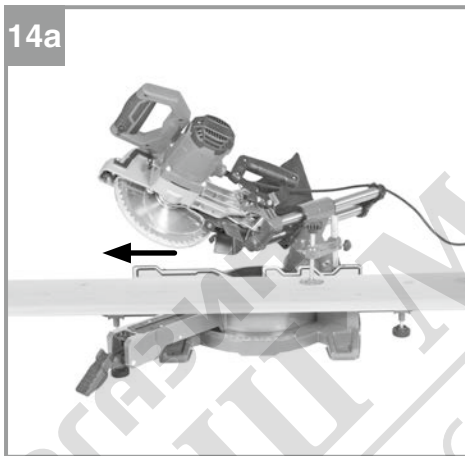
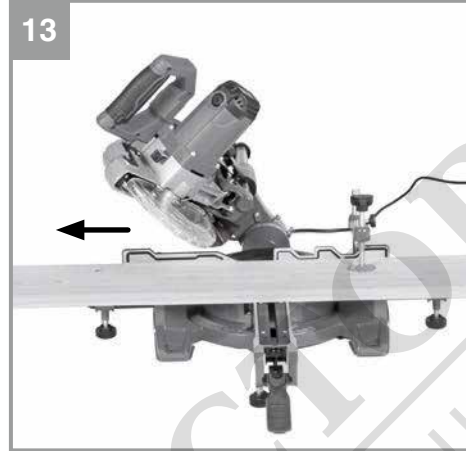
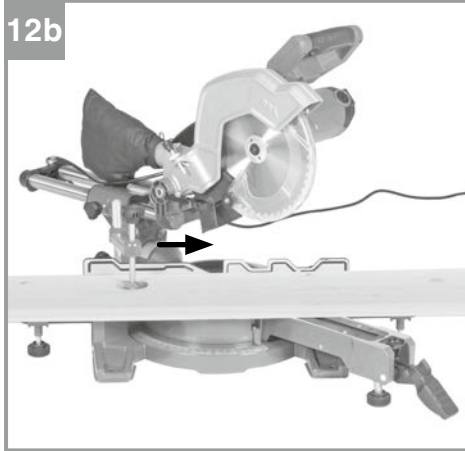

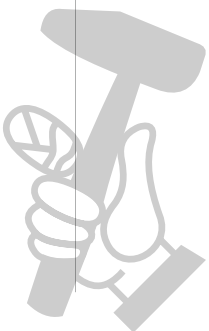
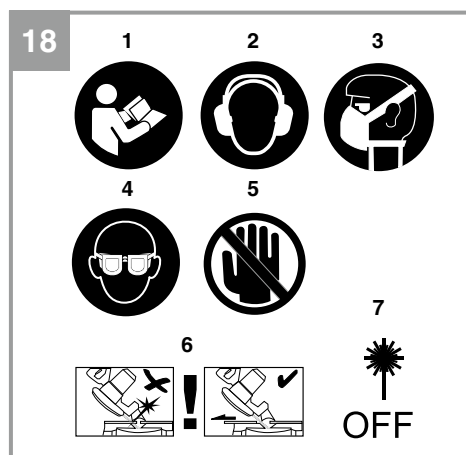
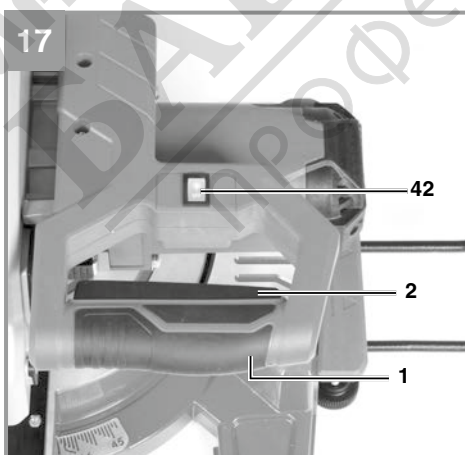
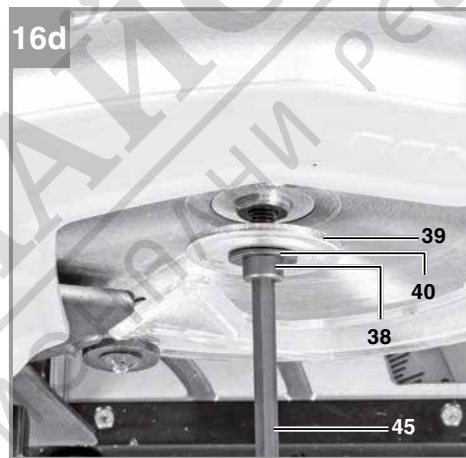
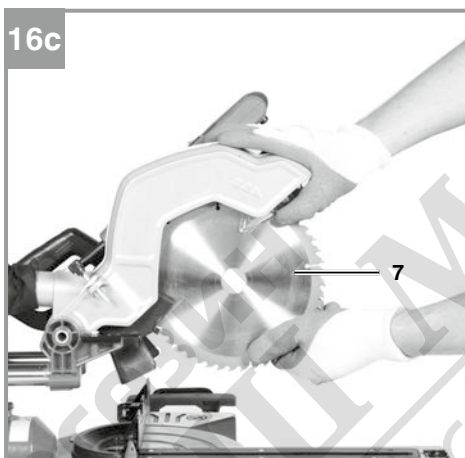
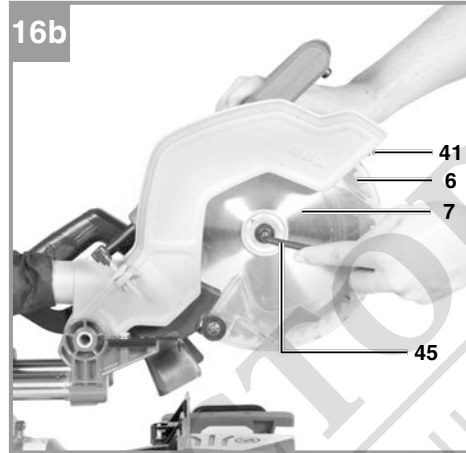
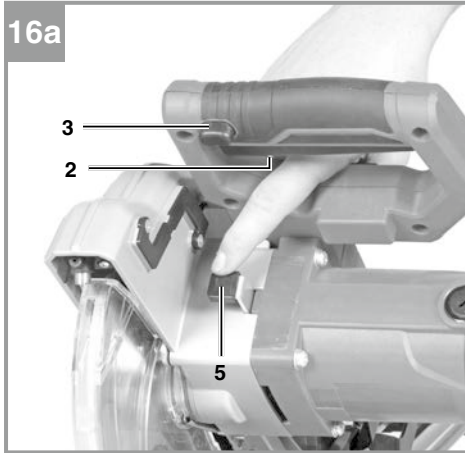

**Danger!**

When using the equipment, a few safety precautions must be observed to avoid injuries and damage. Please read the complete operating instructions and safety regulations with due care. Keep this manual in a safe place, so that the information is available at all times. If you give the equipment to any other person, hand over these operating instructions and safety regulations as well. We cannot accept any liability for damage or accidents which arise due to a failure to follow these instructions and the safety instructions.

**Explanation of the symbols used (see Fig. 18)**

1. **Danger!** - Read the operating instructions to reduce the risk of injury
2. **Caution! Wear ear-muffs.** The impact of noise can cause damage to hearing.
3. **Caution! Wear a breathing mask.** Dust which is injurious to health can be generated when working on wood and other materials. Never use the device to work on any materials containing asbestos!
4. **Caution! Wear safety goggles.** Sparks generated during working or splinters, chips and dust emitted by the device can cause loss of sight.
5. **Caution! Risk of injury! Do not** reach into the running saw blade.
6. **Warning!** To make miter cuts (with the saw head inclined or the turntable set at an angle), the adjustable stop rail must be fixed at an outer position.  
To make 90° crosscuts, the adjustable stop rail must be fixed at the inner position.
7. **On/Off switch for laser**

**1. Safety regulations**

The corresponding safety information can be found in the enclosed booklet.

**Warning!**

**Read all the safety information, instructions, illustrations and technical data provided on or with this power tool.** Failure to adhere to the following instructions may result in electric shock, fire and/or serious injury.

**Keep all the safety information and instructions in a safe place for future use.**

**Special information about the laser**

**⚠ Caution! Laser radiation**  
**Do not look into the beam**  
**Laser class 2**



- Never look directly into the laser path.
- Never direct the laser beam at reflecting surfaces or persons or animals. Even a low output laser beam can inflict injury on the eye.
- **Caution:** It is vital to follow the work procedures described in these instructions. Using the equipment in any other way may result in hazardous exposure to laser radiation.
- Never open the laser module.
- It is prohibited to carry out any modifications to the laser to increase its power.
- The manufacturer cannot accept any liability for damage due to non-observance of the safety information.

**2. Layout and items supplied****2.1 Layout (Fig. 1-3)**

1. Handle
2. On/Off switch
3. Release button
4. Machine head
5. Saw shaft lock
6. Adjustable blade guard
7. Saw blade
8. Clamping device
9. Guide for workpiece support
10. Workpiece support
11. Locking grip for workpiece support
12. Screw for workpiece support
13. Fixed stop rail
14. Movable stop rail
15. Locking grip for movable stop rail
16. Table insert
17. Adjustable foot
18. Fixed saw table
19. Turntable
20. Locking lever
21. Release button

22. Pointer (turntable)
23. Scale (turntable)
24. Pointer (miter)
25. Scale (miter)
26. Locking grip
27. Sawdust bag
28. Discharge opening
29. Locking screw for drag guide
30. Retaining pin
31. Knurled screw for cutting depth limiter
32. Lock nut for cutting depth limiter
33. Stop plate for cutting depth limiter
34. Screw for cutting depth limiter
35. Adjustment screw for angle stop 90°
36. Adjustment screw for angle stop 45°
37. Lock nut for angle stop
38. Flange bolt
39. Outer flange
40. Washer
41. Laser
42. On/Off switch for laser
43. Socket head screw for workpiece support
44. Adjustment screw for stop rail
45. Hexagon key 6mm

## 2.2 Items supplied

Please check that the article is complete as specified in the scope of delivery. If parts are missing, please contact our service center or the sales outlet where you made your purchase at the latest within 5 working days after purchasing the product and upon presentation of a valid bill of purchase. Also, refer to the warranty table in the service information at the end of the operating instructions.

- Open the packaging and take out the equipment with care.
- Remove the packaging material and any packaging and/or transportation braces (if available).
- Check to see if all items are supplied.
- Inspect the equipment and accessories for transport damage.
- If possible, please keep the packaging until the end of the guarantee period.

### Danger!

**The equipment and packaging material are not toys. Do not let children play with plastic bags, foils or small parts. There is a danger of swallowing or suffocating!**

- Drag, crosscut and miter saw
- Clamping device
- Guide for workpiece support (2x)

- Workpiece support (2x)
- Screw for workpiece support (2x)
- Sawdust bag
- Socket head screw for workpiece support (2x)
- 6mm hex key
- Original operating instructions
- Safety information

## 3. Proper use

The drag, crosscut and miter saw is designed for cross-cutting wood and wood-type materials which are appropriate for the machine's size. The saw is **not** designed for cutting firewood.

The equipment is to be used only for its prescribed purpose. Any other use is deemed to be a case of misuse. The user / operator and **not** the manufacturer will be liable for any damage or injuries of any kind caused as a result of this.

Please note that our equipment has **not** been designed for use in commercial, trade or industrial applications. Our warranty will be voided if the machine is used in commercial, trade or industrial businesses or for equivalent purposes.

The equipment is to be operated only with suitable saw blades. It is prohibited to use any type of cutting-off wheel.

To use the equipment properly you must also observe the safety information, the assembly instructions and the operating instructions to be found in this manual.

All persons who use and service the equipment have to be acquainted with these operating instructions and must be informed about the equipment's potential hazards. It is also imperative to observe the accident prevention regulations in force in your area. The same applies for the general rules of health and safety at work.

The manufacturer will **not** be liable for any changes made to the equipment nor for any damage resulting from such changes. Even when the equipment is used as prescribed it is still impossible to eliminate certain residual risk factors.

The following hazards may arise in connection with the machine's construction and design:

- Contact with the saw blade in the uncovered saw zone.
- Reaching into the running saw blade (cut inju-

- ries).
- Kick-back of workpieces and parts of workpieces.
- Saw blade fracturing.
- Catapulting of faulty carbide tips from the saw blade.
- Damage to hearing if essential ear-muffs are **not** used.
- Harmful emissions of wood dust when used in closed rooms.

#### 4. Technical data

AC motor: .....220-240 V ~ 50Hz  
 Power: .....1500 W S1 / 1600 W S6 25%  
 Idle speed  $n_0$ : .....5200 min<sup>-1</sup>  
 Carbide saw blade: ..... $\varnothing$  216 x  $\varnothing$  30 x 2.4 mm  
 Maximum tooth pitch ..... 2.8 mm  
 Number of teeth: ..... 48  
 Swiveling range: ..... -47° / 0° / +47°  
 Miter cut to the left: .....0° to 45°  
 Saw width at 90°: .....305 x 65 mm  
 Saw width at 45°: .....215 x 65 mm  
 Saw width at 2 x 45°  
 (double miter cut, left): .....215 x 35 mm  
 Weight: ..... approx. 13 kg  
 Laser class: ..... 2  
 Wavelength of laser: ..... 650 nm  
 Laser output: .....  $\leq$  1 mW  
 Protection class: ..... II/III

Minimum workpiece size: Only ever cut workpieces which are big enough to clamp securely with the clamping device – minimum length 160 mm.

Operating mode S6 25%: Continuous operation with idling (cycle time 10 minutes). To ensure that the motor does **not** become excessively hot, it may only be operated for 25% of the cycle at the specified rating and must then be allowed to idle for 75% of the cycle.

#### **Danger!** **Noise**

The noise emission values were measured in accordance with EN 62841.

$L_{pA}$  sound pressure level ..... 95.8 dB(A)  
 $K_{pA}$  uncertainty ..... 3 dB(A)  
 $L_{WA}$  sound power level ..... 108.8 dB(A)  
 $K_{WA}$  uncertainty ..... 3 dB(A)

#### **Wear ear-muffs.**

The impact of noise can cause damage to hearing.

The stated noise emission values were measured in accordance with a set of standardized criteria and can be used to compare one power tool with another.

The stated noise emission values can also be used to make an initial assessment of exposure.

#### **Warning:**

The noise emission levels may vary from the level specified during actual use, depending on the way in which the power tool is used, especially the type of workpiece it is used for.

#### **Keep the noise emissions and vibrations to a minimum.**

- Only use appliances which are in perfect working order.
- Service and clean the appliance regularly.
- Adapt your working style to suit the appliance.
- Do **not** overload the appliance.
- Have the appliance serviced whenever necessary.
- Switch the appliance off when it is **not** in use.

#### **Caution!**

##### **Residual risks**

**Even if you use this electric power tool in accordance with instructions, certain residual risks cannot be ruled out. The following hazards may arise in connection with the equipment's construction and layout:**

1. Lung damage if no suitable protective dust mask is used.
2. Damage to hearing if no suitable ear protection is used.
3. Health damage caused by hand-arm vibrations if the equipment is used over a prolonged period or is **not** properly guided and maintained.

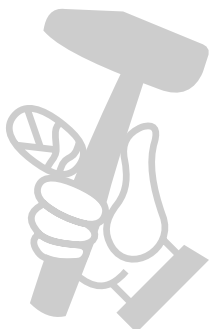

## 5. Before starting the equipment

Before you connect the equipment to the mains supply make sure that the data on the rating plate are identical to the mains data.

### Warning!

**Always pull the power plug before making adjustments to the equipment.**

### 5.1 General information

- The equipment must be set up where it can stand securely, i.e. it should be bolted to a workbench, a universal base frame or similar.
- All covers and safety devices have to be properly fitted before the equipment is switched on.
- It must be possible for the blade to run freely.
- When working with wood that has been processed before, watch out for foreign bodies such as nails or screws, etc.
- Before you actuate the On/Off switch, make sure that the saw blade is correctly fitted and that the equipment's moving parts run smoothly.

### 5.2 Assembling the saw (Fig. 1-5)

- Thread the workpiece supports (10) onto the guides (9) (Fig. 4). Then fit the guides onto the fixed saw table (18) and fasten them with the screw (12). Use a crosstip screwdriver to do this.
- The workpiece support (10) can be moved on the guide (9) to adjust it to the length of the workpiece you want to saw. Place the workpiece support (10) in the required position and fasten it by tightening the socket head screw (43) with the hex key (45).
- **Important!** The hex key (45) can be kept at the back of the machine (see Fig. 2b).
- To prevent the saw from tilting when you work on long or large workpieces, you can adjust the workpiece support (10) to suit the underlying surface. To do so, screw down the locking grip (11) until it touches the supporting surface.
- To fit the sawdust bag (27) to the discharge opening (28) on the crosscut saw, spread the metal ring apart on the opening. When the metal ring is back in its original shape, the sawdust bag is held securely in position.
- The clamping device (8) can be fitted on the left or right of the fixed saw table (18).
- A crosstip screwdriver is **not** supplied with the product.

### 5.3 Adjusting the saw (Fig. 1-3)

- To adjust the turntable (19), the locking lever (20) must be in the top position. Only then is it possible to adjust the turntable while holding the release button (21) pressed down. (see Fig. 5)
- Turn the turntable (19) and scale pointer (22) to the desired angular setting on the scale (23).
- The saw has locking positions at angles of -45°, -30°, -22.5°, -15°, 0°, 15°, 22.5°, 30° and 45°, at which the turntable (19) audibly clicks into position. Once the turntable is engaged, the setting must be additionally secured by pressing the locking lever (20) down.
- If different angle settings are required, the turntable (19) may be secured in position using only the locking lever (20).
- To release the saw from its position at the bottom, pull the retaining pin (30) out of the motor mounting while pressing down lightly on the machine head (4).
- Swing up the machine head (4).
- When the locking grip (26) is undone, you can tilt the machine head (4) to the left by up to 45°. After the desired angular setting has been set on the scale pointer (24) on the scale (25), secure the machine head (4) again with the locking grip (26).
- To ensure that the saw is standing securely, adjust the adjustable foot (17) by turning it so that the saw stands in a horizontal and firm position.
- The machine head (4) can be moved backwards and forwards using the drag function. To prevent the drag function, the guide rails can be fixed in a specific position with the locking screw (29).

### 5.4 Precision adjustment of the stop rail (Fig. 6, 7)

- Lower the machine head (4) and fasten in place with the retaining pin (30).
- Fasten the turntable (19) in 0° position.
- Place the 90° stop angle (a) between the blade (7) and the stop rail (13).
- Slacken the four adjustment screws (44) using a hex key, set the stop rail (13) to 90° in relation to the saw blade (7) and retighten the adjustment screws (44).
- The angle stop (a) and hex key (5 mm) are **not** included in the scope of this delivery.

### 5.5 Precision adjustment of the angle stop for crosscut 90° (Fig. 8, 9)

- Lower the machine head (4) and fasten in place with the retaining pin (30).
- Fasten the turntable (19) in 0° position.
- Undo the locking grip (26) and tilt the machine head (4) all the way to the right to 0° using the handle (1).
- Place the 90° angular stop (a) between the blade (7) and the turntable (19).
- Slacken the lock nut (37) and adjust the adjustment screw (35) until the angle between the blade (7) and the turntable (19) equals 90°.
- Retighten the lock nut (37) to secure this setting.
- Finally, check the position of the pointer (24). If necessary, release the pointer with a crosstip screwdriver, move to the 0° position of the angle scale (25) and retighten the pointer.
- The angle stop (a) and crosstip screwdriver are **not** included in the scope of this delivery.

### 5.6 Precision adjustment of the angle stop for miter cut 45° (Fig. 8, 10)

- Lower the machine head (4) and fasten in place with the retaining pin (30).
- Fasten the turntable (19) in 0° position.
- Undo the locking grip (26) and tilt the machine head (4) all the way to the left to 45° using the handle (1).
- Place the 45° stop angle (b) between the blade (7) and the turntable (19).
- Slacken the lock nut (37) and adjust the adjustment screw (36) until the angle between the blade (7) and the turntable (19) equals exactly 45°.
- Retighten the lock nut to secure this setting.
- No angle stop (b) included.

## 6. Operation

**Warning!** To make 90° crosscuts, the adjustable stop rail (14) must be fixed at the inner position:

- Undo the locking grip (15) for the adjustable stop rail and push the adjustable stop rail inwards.
- The adjustable stop rail (14) must be fixed far enough in front of the innermost position that the distance between the stop rail (14) and the saw blade (7) amounts to a maximum of 5mm.
- Before making a cut, check that the stop rail

and the saw blade cannot collide.

- Tighten the locking grip (15) again.

**Warning!** To make 0°-45° miter cuts (with the machine head (4) inclined or the turntable set at an angle), the adjustable stop rail (14) must be fixed at an outer position.

- Undo the locking grip (15) for the adjustable stop rail and push the adjustable stop rail outwards.
- The adjustable stop rail (14) must be fixed far enough in front of the innermost position that the distance between the stop rail (14) and the saw blade (7) amounts to a maximum of 5mm.
- Before making a cut, check that the stop rail and the saw blade cannot collide.
- Tighten the locking grip (15) again.

### 6.1 Cross cut 90° and turntable 0° (Fig. 1-3, 11)

For cutting widths up to approx. 100 mm it is possible to fix the saw's drag function with the locking screw for drag guide (29) in rear position. If the cutting width exceeds 100 mm you must ensure that the locking screw for drag guide (29) is slackened and that the machine head (4) can be moved.

- Move the machine head (4) to its upper position.
- Use the handle (1) to push back the machine head (4) and fix it in this position if required (dependent on the cutting width).
- Place the piece of wood to be cut at the stop rail (13) and on the turntable (19).
- Lock the material with the clamping device (8) on the fixed saw table (18) to prevent the material from moving during the cutting operation.
- Press the release button (3) to release the On/Off switch (2).
- Press the On/Off switch (2) to start the motor.
- With the drag guide fixed in place: Use the handle (1) to move the machine head (4) steadily and with light pressure downwards until the saw blade (7) has completely cut through the workpiece.
- With the drag guide **not** fixed in place: Pull the machine head (4) all the way to the front and then use the handle (1) to move it downwards steadily and with light pressure. Now push the machine head (4) slowly and steadily to the very back until the saw blade (7) has completely cut through the workpiece.

- When the cutting operation is completed, move the machine head (4) back to its upper (home) position and release the On/Off button (2).

**Important!** The integral resetting springs will automatically lift the machine head. Do **not** simply let go of the handle (1) after cutting, but allow the machine head (4) to rise slowly, applying slight counter pressure as it does so.

### 6.2 Cross cut 90° and turntable 0° - 45° (Fig. 1-3, 12)

The crosscut saw can be used to make crosscuts of 0°- 45° to the left and 0° - 45° to the right in relation to the stop rail.

- Swing up the machine head (4).
- Move the locking lever (20) to its top position to enable the turntable to be adjusted.
- While holding the release button (21) pressed down, turn the turntable (19) and scale pointer (22) to the desired angular setting on the scale (23).
- To lock the turntable (19), press the locking lever (20) down.
- Cut as described in section 6.1.

### 6.3 Miter cut 0°- 45° and turntable 0° (Fig. 1-3, 13)

The crosscut saw can be used to make miter cuts of 0- 45° in relation to the work face.

- Move the machine head (4) to its upper position.
- Fasten the turntable (19) in 0° position.
- Release the locking grip (26) and tilt the machine head (4) to the left until it coincides with the required angular setting on the scale pointer (24) on the scale (25). Then secure the locking grip (26) again.
- Cut as described in section 6.1.

### 6.4 Miter cut 0°- 45° and turntable 0°- 45° (Fig. 1-3, 14)

The crosscut saw can be used to make miter cuts to the left of 0°-45° in relation to the work surface, with simultaneous setting of the turntable from 0°-45° to the left or 0°-45° to the right in relation to the stop rail (double miter cut).

- Move the machine head (4) to its upper position.
- Move the locking lever (20) to its top position to enable the turntable to be adjusted.
- While holding the release button (21) pressed down, turn the turntable (19) and scale pointer (22) to the desired angular setting on the scale (23).

- To lock the turntable (19), press the locking lever (20) down.
- Release the locking grip (26) and tilt the machine head (4) to the left until it coincides with the required angular setting on the scale pointer (24) on the scale (25). Then secure the locking grip (26) again.
- Cut as described in section 6.1.

### 6.5 Limiting the cutting depth (Fig. 15)

- The cutting depth limiter can be activated with the help of the screw (34).
- To do so, slacken the screw (34) using a crosstip screwdriver, so that the stop plate can be moved. Then move the stop plate (33) as far as possible towards the saw blade and retighten the screw (34) afterwards.
- The cutting depth can be infinitely adjusted using the knurled screw (31). To do so, slacken the lock nut (32) and set the required cutting depth by turning the knurled screw (31) in or out. Then retighten the lock nut (32) on the screw (31).
- Check the setting by completing a test cut.
- A crosstip screwdriver is **not** supplied with the product.

### 6.6 Sawdust bag (Fig. 2)

The saw is equipped with a sawdust bag (27) for sawdust and chips.

The sawdust bag (27) can be emptied by means of a zipper at the bottom.

### 6.7 Replacing the saw blade (Fig. 1, 16)

- Before changing the saw blade: Pull out the power plug!
- Wear work gloves to prevent injury when changing the saw blade.
- Swing the machine head upwards (4).
- Press the saw shaft lock (5) with one hand while positioning the hexagon key (45) on the flange bolt (38) with the other hand. The saw shaft lock (5) engages after no more than one rotation.
- Now, using a little more force, slacken the flange screw (38) in the clockwise direction.
- Turn the flange screw (38) right out and remove the washer (40) and the outer flange (39).
- Take the blade (7) off the inner flange and pull out downwards. To do so, move the saw blade guard (6) up to enable access to the saw blade.
- Carefully clean the flange screw (38), washer (40), outer flange (39) and inner flange.

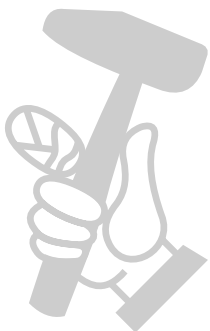

- Fit and fasten the new saw blade (7) in reverse order.
- **Important!** The cutting angle of the teeth, in other words the direction of rotation of the saw blade (7) must coincide with the direction of the arrow on the housing.
- Check to make sure that all safety devices are properly mounted and in good working condition before you begin working with the saw again.
- **Warning!** Every time that you change the saw blade, check that the saw blade guard (6) opens and closes again in accordance with requirements. Also check that the saw blade (7) spins freely in the saw blade guard (6).
- **Warning!** Every time that you change the saw blade, check to see that it spins freely in the table insert (16) in both perpendicular and 45° angle settings.
- **Warning!** You should replace the table insert (16) immediately whenever it is worn or damaged. To do so, undo the Philips screws in the table insert (16) and take the table insert out of the fixed saw table (18). To fit the new table insert (16), proceed in reverse order.
- **Warning!** The work to change and align the saw blade (7) must be carried out correctly.

#### 6.8 Transport (Fig. 1-3)

- Press down the locking lever (20) to lock the turntable (19).
- Using the scale (25), make sure that the angle for miter cuts is 90°. In addition, the machine head (4) must be secured with the locking grip (26).
- Press the machine head (4) downwards and secure with the retaining pin (30). The saw is now locked in its bottom position.
- Fix the saw's drag function with the locking screw for drag guide (29) in rear position.
- Carry the equipment by the fixed saw table (18).
- To set up the equipment again, proceed as described in section 5.3.

#### 6.9 Operating the laser (Fig. 1, 17)

**Switching on:** Move the On/Off switch (42) to the "☀" position to switch on the laser (41). A laser line is projected onto the material you wish to process, providing an exact guide for the cut.

**Switching off:** Move the On/Off switch (42) to the "OFF" position.

## 7. Replacing the power cable

### Danger!

If the power cable for this equipment is damaged, it must be replaced by the manufacturer or its after-sales service or similarly trained personnel to avoid danger.

## 8. Cleaning, maintenance and ordering of spare parts

### Danger!

Always pull out the mains power plug before starting any cleaning work.

#### 8.1 Cleaning

- Keep all safety devices, air vents and the motor housing free of dirt and dust as far as possible. Wipe the equipment with a clean cloth or blow it with compressed air at low pressure.
- We recommend that you clean the device immediately each time you have finished using it.
- Clean the equipment regularly with a moist cloth and some soft soap. Do **not** use cleaning agents or solvents; these could attack the plastic parts of the equipment. Ensure that no water can seep into the device. The ingress of water into an electric tool increases the risk of an electric shock.

#### 8.2 Carbon brushes

In case of excessive sparking, have the carbon brushes checked only by a qualified electrician. **Danger!** The carbon brushes should **not** be replaced by anyone but a qualified electrician.

#### 8.3 Maintenance

- There are no parts inside the equipment which require additional maintenance.
- Lubricate all moving parts at regular intervals.

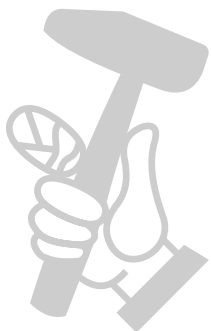

#### 8.4 Ordering spare parts and accessories

Please provide the following information when ordering spare parts:

- Type of unit
- Article number of the unit
- ID number of the unit
- Spare part number of the required spare part

For our latest prices and information please go to [www.Einhell-Service.com](http://www.Einhell-Service.com)



Tip! For good results we recommend high-quality accessories from **kwb** !  
[www.kwb.eu](http://www.kwb.eu)  
[welcome@kwb.eu](mailto:welcome@kwb.eu)

#### 9. Disposal and recycling

The equipment is supplied in packaging to prevent it from being damaged in transit. The raw materials in this packaging can be reused or recycled. The equipment and its accessories are made of various types of material, such as metal and plastic. Never place defective equipment in your household refuse. The equipment should be taken to a suitable collection center for proper disposal. If you do **not** know the whereabouts of such a collection point, you should ask in your local council offices.

#### 10. Storage

Store the equipment and accessories in a dark and dry place at above freezing temperature. The ideal storage temperature is between 5 and 30 °C. Store the electric tool in its original packaging.

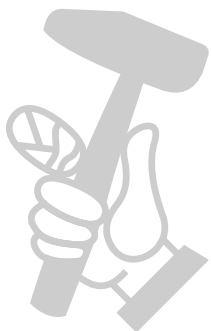



For EU countries only

Never place any electric power tools in your household refuse.

To comply with European Directive 2012/19/EC concerning old electric and electronic equipment and its implementation in national laws, old electric power tools have to be separated from other waste and disposed of in an environment-friendly fashion, e.g. by taking to a recycling depot.

Recycling alternative to the return request:

As an alternative to returning the equipment to the manufacturer, the owner of the electrical equipment must make sure that the equipment is properly disposed of if he no longer wants to keep the equipment. The old equipment can be returned to a suitable collection point that will dispose of the equipment in accordance with the national recycling and waste disposal regulations. This does **not** apply to any accessories or aids without electrical components supplied with the old equipment.

Please note that batteries and lamps (e.g. light bulbs) must be removed from the tool before it is disposed of.

The reprinting or reproduction by any other means, in whole or in part, of documentation and papers accompanying products is permitted only with the express consent of the Einhell Germany AG.

Subject to technical changes

- The product meets the requirements of EN 61000-3-11 and is subject to special connection conditions. This means that use of the product at any freely selectable connection point is **not** allowed.
- Given unfavorable conditions in the power supply the product can cause the voltage to fluctuate temporarily.
- The product is intended solely for use at connection points that
  - a) do **not** exceed a maximum permitted supply impedance „Z“, or
  - b) have a continuous current-carrying capacity of the mains of at least 100 A per phase.
- As the user, you are required to ensure, in consultation with your electric power company if necessary, that the connection point at which you wish to operate the product meets one of the two requirements, a) or b), named above.

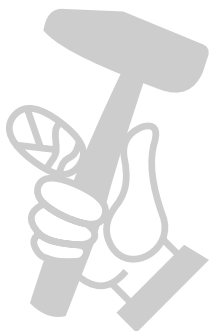

## Service information

We have competent service partners in all countries named on the guarantee certificate whose contact details can also be found on the guarantee certificate. These partners will help you with all service requests such as repairs, spare and wearing part orders or the purchase of consumables.

Please note that the following parts of this product are subject to normal or natural wear and that the following parts are therefore also required for use as consumables.

Category	Example
Wear parts*	Carbon brushes
Consumables*	Saw blade
Missing parts	

\* Not necessarily included in the scope of delivery!

In the effect of defects or faults, please register the problem on the internet at [www.Einhell-Service.com](http://www.Einhell-Service.com). Please ensure that you provide a precise description of the problem and answer the following questions in all cases:

- Did the equipment work at all or was it defective from the beginning?
- Did you notice anything (symptom or defect) prior to the failure?
- What malfunction does the equipment have in your opinion (main symptom)? Describe this malfunction.

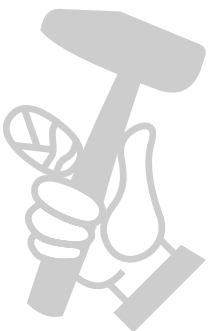

## Warranty certificate

Dear Customer,

All of our products undergo strict quality checks to ensure that they reach you in perfect condition. In the unlikely event that your device develops a fault, please contact our service department at the address shown on this guarantee card. You can also contact us by telephone using the service number shown. Please note the following terms under which guarantee claims can be made:

1. These guarantee terms apply to consumers only, i.e. natural persons intending to use this product neither for their commercial activities nor for any other self-employed activities. These warranty terms regulate additional warranty services, which the manufacturer mentioned below promises to buyers of its new products in addition to their statutory rights of guarantee. Your statutory guarantee claims are not affected by this guarantee. Our guarantee is free of charge to you.
2. The warranty services cover only defects due to material or manufacturing faults on a product which you have bought from the manufacturer mentioned below and are limited to either the rectification of said defects on the product or the replacement of the product, whichever we prefer.  
Please note that our devices are not designed for use in commercial, trade or professional applications. A guarantee contract will not be created if the device has been used by commercial, trade or industrial business or has been exposed to similar stresses during the guarantee period.
3. The following are not covered by our guarantee:
  - Damage to the device caused by a failure to follow the assembly instructions or due to incorrect installation, a failure to follow the operating instructions (for example connecting it to an incorrect mains voltage or current type) or a failure to follow the maintenance and safety instructions or by exposing the device to abnormal environmental conditions or by lack of care and maintenance.
  - Damage to the device caused by abuse or incorrect use (for example overloading the device or the use of unapproved tools or accessories), ingress of foreign bodies into the device (such as sand, stones or dust, transport damage), the use of force or damage caused by external forces (for example by dropping it).
  - Damage to the device or parts of the device caused by normal or natural wear or tear or by normal use of the device.
4. The guarantee is valid for a period of 24 months starting from the purchase date of the device. Guarantee claims should be submitted before the end of the guarantee period within two weeks of the defect being noticed. No guarantee claims will be accepted after the end of the guarantee period. The original guarantee period remains applicable to the device even if repairs are carried out or parts are replaced. In such cases, the work performed or parts fitted will not result in an extension of the guarantee period, and no new guarantee will become active for the work performed or parts fitted. This also applies if an on-site service is used.
5. To make a claim under the guarantee, please register the defective device at: [www.Einhell-Service.com](http://www.Einhell-Service.com). Please keep your bill of purchase or other proof of purchase for the new device. Devices that are returned without proof of purchase or without a rating plate shall not be covered by the guarantee, because appropriate identification will not be possible. If the defect is covered by our guarantee, then the item in question will either be repaired immediately and returned to you or we will send you a new replacement.

Of course, we are also happy offer a chargeable repair service for any defects which are not covered by the scope of this guarantee or for units which are no longer covered. To take advantage of this service, please send the device to our service address.

Also refer to the restrictions of this warranty concerning wear parts, consumables and missing parts as set out in the service information in these operating instructions.

