

Einhell

TE-AC 430/90/10

D	Originalbetriebsanleitung Kompressor	E	Manual de instrucciones original Compressor
GB	Original operating instructions Compressor	FIN	Alkuperäiskäyttöohje Kompressor
F	Instructions d'origine Compresseur	SLO	Originalna navodila za uporabo Kompressor
I	Istruzioni per l'uso originali Compressore	H	Eredeti használati utasítás Kompresszor
DK/ N	Original betjeningsvejledning Kompressor	RO	Instrucțiuni de utilizare originale Compressor
S	Original-bruksanvisning Kompressor	GR	Πρωτότυπες Οδηγίες χρήσης Συμπιεστής
CZ	Originální návod k obsluze Kompressor		
SK	Originálny návod na obsluhu Kompressor		
NL	Originele handleiding Compressor		



Art.-Nr.: 40.108.00

I.-Nr.: 11018

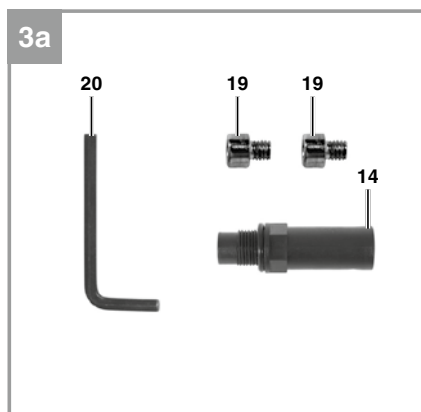
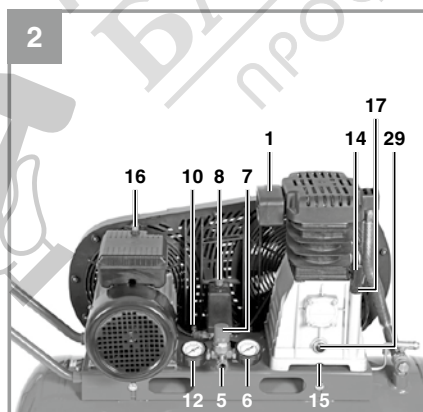
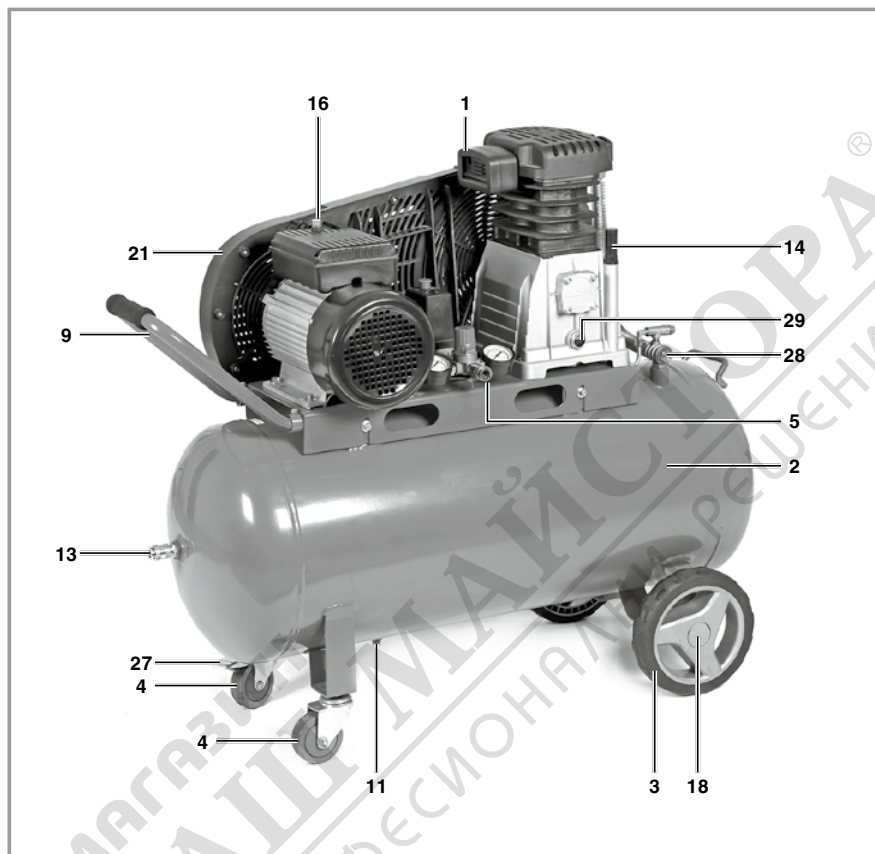

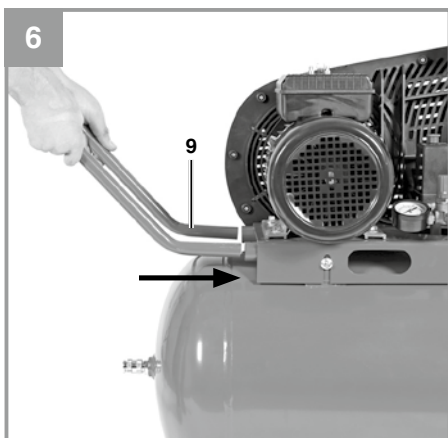
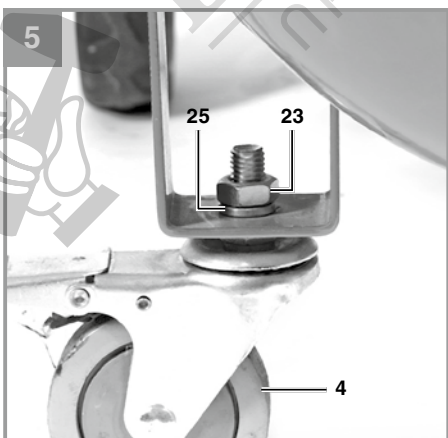
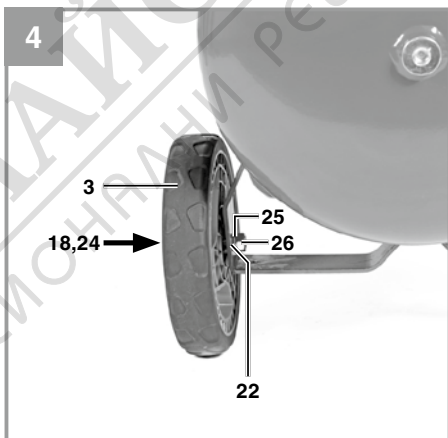
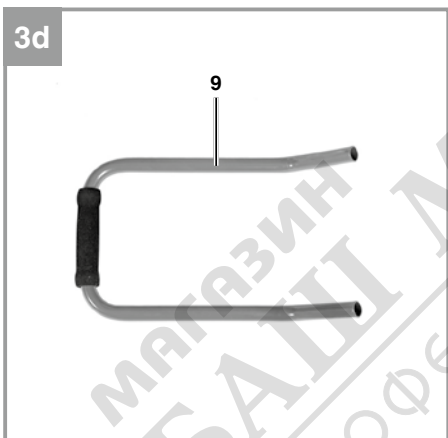
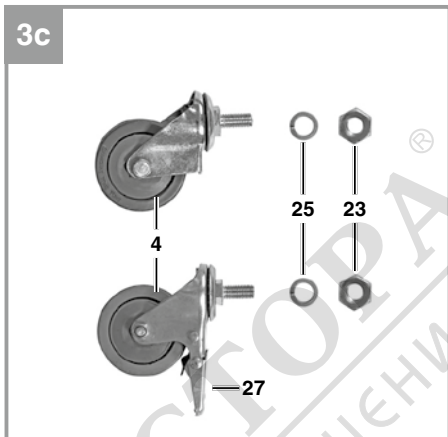
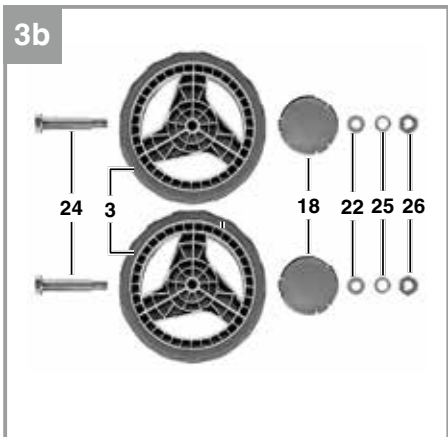

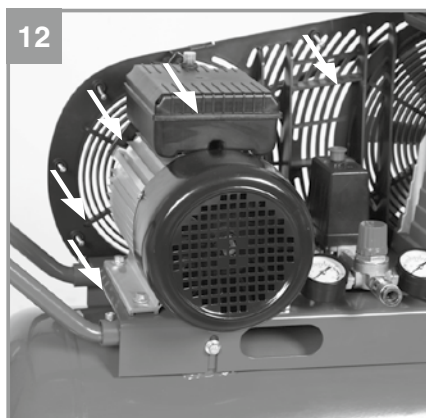
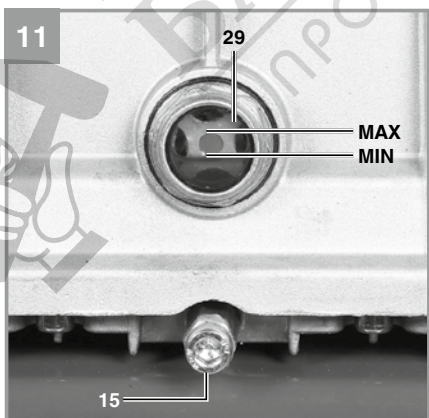
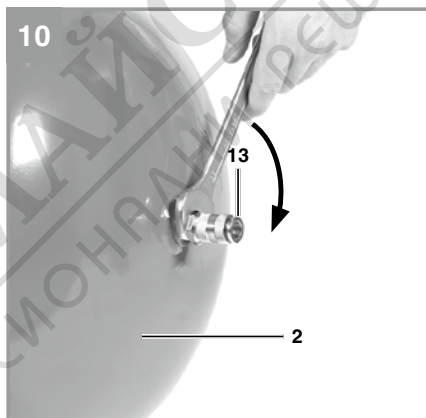
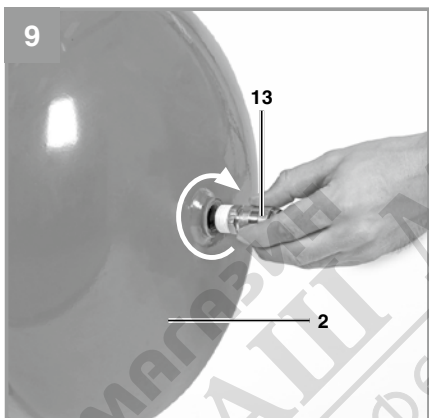
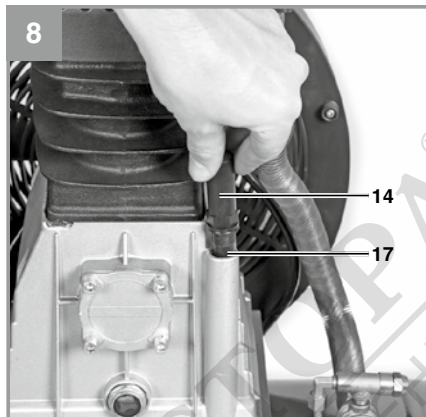
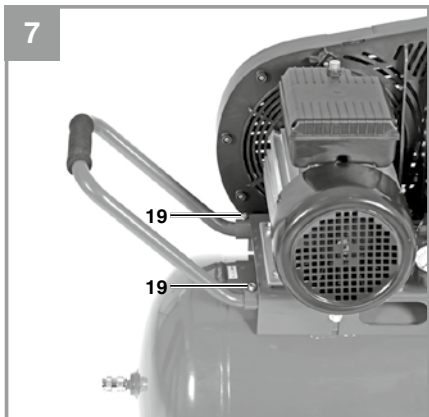

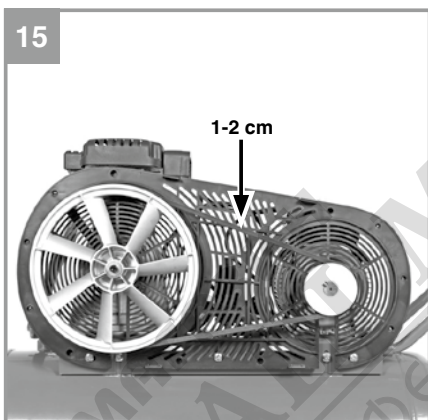
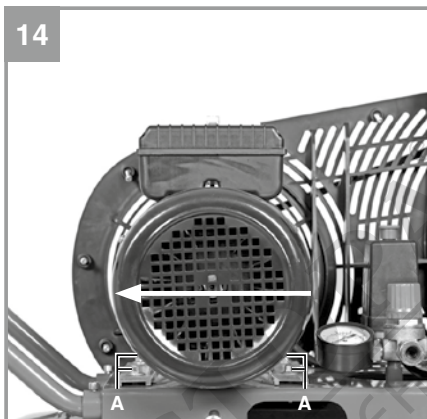
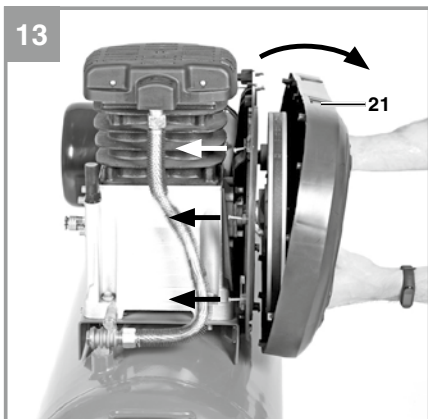



Warning - Read the operating instructions to reduce the risk of injury



Warning! Wear ear-muffs. The impact of noise can cause damage to hearing.



Warning of electrical voltage!



Warning of hot parts!



Warning! The unit will start up automatically without warning if the pressure drops below cut-in pressure!



Notice! Before using for the first time, check the oil level and replace the oil sealing plug!

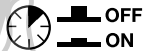

Overload switch

Danger!

When using the equipment, a few safety precautions must be observed to avoid injuries and damage. Please read the complete operating instructions and safety regulations with due care. Keep this manual in a safe place, so that the information is available at all times. If you give the equipment to any other person, hand over these operating instructions and safety regulations as well. We cannot accept any liability for damage or accidents which arise due to a failure to follow these instructions and the safety instructions.

1. Safety regulations

The corresponding safety information can be found in the enclosed booklet.

Danger!**Read all safety regulations and instructions.**

Any errors made in following the safety regulations and instructions may result in an electric shock, fire and/or serious injury.

Keep all safety regulations and instructions in a safe place for future use.

This appliance is not intended for use by persons (including children) with reduced physical, sensory or mental capabilities, or lack of experience and knowledge, unless they have been given supervision or instruction concerning use of the appliance by a person responsible for their safety. Children should be supervised to ensure that they do not play with the appliance.

2. Layout and items supplied**2.1 Layout (Fig. 1-4)**

1. Intake air filter
2. Pressure tank
3. Wheel
4. Guide roller
5. Quick-lock coupling (regulated compressed air)
6. Pressure gauge (for reading the set pressure)
7. Pressure regulator
8. On/Off switch
9. Transport handle
10. Safety valve
11. Drainage screw for condensation water
12. Pressure gauge (for reading the vessel pressure)

13. Quick-lock coupling (unregulated compressed air)
14. Oil sealing plug
15. Oil drainage screw
16. Overload switch
17. Oil filler opening
18. Wheel cap
19. Screw (internal hexagon) for fitting the handle
20. Hexagon key
21. Safety guard for V-belt
22. Washer
23. Nut for fitting the castors
24. Axle screw
25. Spring washer
26. Nut for fitting the axle
27. Castor brake
28. Non-return valve
29. Oil level window

2.2 Items supplied

Please check that the article is complete as specified in the scope of delivery. If parts are missing, please contact our service center or the nearest branch of the DIY store where you made your purchase at the latest within 5 work days after purchasing the article and upon presentation of a valid bill of purchase. Also, refer to the warranty table in the warranty provisions at the end of the operating instructions.

- Open the packaging and take out the equipment with care.
- Remove the packaging material and any packaging and/or transportation braces (if available).
- Check to see if all items are supplied.
- Inspect the equipment and accessories for transport damage.
- If possible, please keep the packaging until the end of the guarantee period.

Danger!

The equipment and packaging material are not toys. Do not let children play with plastic bags, foils or small parts. There is a danger of swallowing or suffocating!

- Wheel (2x)
- Guide roller (2x)
- Transport handle
- Oil sealing plug
- Wheel cap (2x)
- Screw (hexagon) for fitting the handle (2x)
- Hexagon key
- Washer (2x)
- Nut for fitting the castors (2x)

- Spring washer (4x)
- Nut for fitting the axle (2x)
- Hexagon screw (2x)
- Original operating instructions
- Safety information

3. Proper use

The compressor is designed for generating compressed air for tools operated by compressed air.

The equipment is to be used only for its prescribed purpose. Any other use is deemed to be a case of misuse. The user / operator and not the manufacturer will be liable for any damage or injuries of any kind caused as a result of this.

Please note that our equipment has not been designed for use in commercial, trade or industrial applications. Our warranty will be voided if the machine is used in commercial, trade or industrial businesses or for equivalent purposes.

4. Technical data

Mains connection:.....	220-240 V ~ 50 Hz
Motor rating:.....	3000 W
Speed (motor) min ⁻¹ :	2850
Speed (pump) min ⁻¹ :	1020
Operating pressure bar:	max. 10
Pressure vessel capacity (in liters):.....	90
Theoretical suction rate l/min	430
Output (compressed air) at 7 bar: ..	200 liters/min
Output (compressed air) at 4 bar: ...	210 liters/min
Sound power level L _{WA} in dB:.....	97
K _{WA} uncertainty:.....	0.49 dB
Sound pressure level L _{pA} in dB:.....	73
K _{pA} uncertainty:	0.49 dB
Protection type:.....	IP20
Weight of the unit in kg:	approx. 68 kg
Oil quantity:.....	approx. 0.85 liters

Noise

The noise emission values were measured in accordance with EN ISO 3744.

Wear ear-muffs.

The impact of noise can cause damage to hearing.

5. Before starting the equipment

Before you connect the equipment to the mains supply make sure that the data on the rating plate are identical to the mains data.

Warning!

Always pull the power plug before making adjustments to the equipment.

- Examine the machine for signs of transit damage. Report any damage immediately to the company which delivered the compressor.
- The compressor should be set up near the working consumer.
- Avoid long air lines and long supply lines (extensions).
- Make sure the intake air is dry and dust-free.
- Do not set up the compressor in damp or wet rooms.
- The compressor may only be used in suitable rooms (with good ventilation and an ambient temperature from +5°C to +40°C). There must be no dust, acids, vapors, explosive gases or inflammable gases in the room.
- The compressor is designed to be used in dry rooms. It is prohibited to use the compressor in areas where work is conducted with sprayed water.
- The oil level in the compressor pump has to be checked before putting the equipment into operation.
- The equipment must be set up where it can stand securely.
- Use flexible hoses in order to prevent transmitting unacceptable loads to the pipeline system at the connection between the compressor system and the pipeline system.
- It is essential to use separators, traps and drains which process the liquids produced by the compressor before the compressor system is put into operation.
- Supply hoses at pressures above 7 bar should be equipped with a safety cable (e.g. a wire rope).

6. Assembly and starting

Notice!

You must fully assemble the appliance before using it for the first time.

6.1 Fitting the wheels (3)

Fit the supplied wheels as shown in Fig. 4.

6.2 Fitting the castors (4)

Fit the supplied castors (4) as shown in Fig. 5.

6.3 Fitting the transport handle (9)

Screw the transport handle (9) to the compressor as shown in Figures 6 to 7.

6.4 Replacing the oil sealing plug (14)

Remove the transportation cover from the oil filler opening with a screwdriver and insert the supplied oil sealing plug (14) into the oil filler opening (Fig. 8).

6.5 Fitting the quick-lock coupling for tank pressure (13)

Screw the quick-lock coupling for unregulated tank pressure (13) to the pressure vessel (2) as shown in Figures 9 to 10.

6.6 Power supply

- The motor is fitted with an overload switch (Fig. 2/Item 16). If the compressor overloads, the overload switch switches off the equipment automatically to protect the compressor from overheating. If the overload switch triggers, switch off the compressor using the ON/OFF switch (8) and wait until the compressor cools down. Then press the overload switch (16) and restart the compressor.
- Long supply cables, extensions, cable reels etc. cause a drop in voltage and can impede motor start-up.
- In the case of low temperatures below +5°C, motor start-up is jeopardized as a result of stiffness.

6.7 On/Off switch (8)

To switch on the compressor, pull out the knob (8).

To switch off the compressor, press the knob (8) back in. (Figure 2)

6.8 Adjusting the pressure: (Fig. 1,2)

- You can adjust the pressure on the pressure gauge (6) using the pressure regulator (7).
- The set pressure can be taken from the quick-lock coupling (5).

6.9 Setting the pressure switch

The pressure switch is set at the factory.

Switch-on pressure 8 bar

Switch-off pressure 10 bar

7. Replacing the power cable

If the power cable for this equipment is damaged, it must be replaced by the manufacturer or its after-sales service or similarly trained personnel to avoid danger.

8. Cleaning, maintenance and ordering of spare parts

Warning!

Pull the power plug before doing any cleaning and maintenance work on the appliance.

Warning!

Wait until the compressor has completely cooled down. Risk of burns!

Warning!

Always depressurize the tank before carrying out any cleaning and maintenance work.

Warning!

After use, always switch off the equipment immediately and pull out the power plug.

8.1 Cleaning

- Keep the safety devices free of dirt and dust as far as possible. Wipe the equipment with a clean cloth or blow it with compressed air at low pressure.
- We recommend that you clean the appliance immediately after you use it.
- Clean the appliance regularly with a damp cloth and some soft soap. Do not use cleaning agents or solvents; these may be aggressive to the plastic parts in the appliance. Ensure that no water can get into the interior of the appliance.

- You must disconnect the hose and any spraying tools from the compressor before cleaning. Do not clean the compressor with water, solvents or the like.

8.2 Condensation water (Fig. 1)

Notice! To ensure a long service life of the pressure vessel (2), drain off the condensed water by opening the drain valve (11) each time after using. Check the pressure vessel for signs of rust and damage each time before using. Do not use the compressor with a damaged or rusty pressure vessel. If you discover any damage, please contact the customer service workshop.

Notice!

The condensation water from the pressure vessel will contain residual oil. Dispose of the condensation water in an environmentally compatible manner at the appropriate collection point.

8.3 Safety valve (10)

The safety valve has been set for the highest permitted pressure of the pressure vessel. It is prohibited to adjust the safety valve or remove its seal.

8.4 Check the oil level at regular intervals

Place the compressor on a level and straight surface. The oil level must be between the two marks MAX and MIN on the oil level window (Fig. 11).

Changing the oil: Recommended hydraulic oil: SAE 15W/40 or an alternative of the same quality. It should be refilled for the first time after 100 hours of operation. Thereafter the oil should be drained and refilled after every 500 hours in service.

8.5 Changing the oil

Switch off the engine and pull the mains plug out of the socket. After releasing any air pressure you can unscrew the oil drainage screw (15) from the compressor pump. To prevent the oil from running out in an uncontrolled manner, hold a small metal chute under the opening and collect the oil in a vessel. If the oil does not drain out completely, we recommend tilting the compressor slightly.

Dispose of the old oil at a drop-off point for old oil.

When the oil has drained out, re-fit the oil drainage screw (15). Fill new oil through the oil filler opening (17) until it comes up to the required level.

Then replace the oil sealing plug (14).

8.6 Cleaning the intake filter (1)

The intake filter prevents dust and dirt being drawn in. It is essential to clean this filter after at least every 300 hours in operation. A clogged intake filter will decrease the compressor's performance dramatically. Undo the screws on the air filter so that the halves of the air filter housing can be opened. Use compressed air at low pressure (approx. 3 bar) to blow out all the parts of the filter and then assemble the filter in reverse order. When cleaning, take adequate precautions against dust (e.g. use a suitable face mask).

8.7 Retensioning the V-belt (Figs. 12-15)

- Pull out the power plug and remove the safety guard for the V-belt.
- Slacken the four motor fixing screws (A).
- Shift the motor until the V-belt is tensioned to the point where it can still be depressed by approx. 1-2 cm at the longest free position.
- Retighten the motor fixing screws (A) and refit the safety guard for the V-belt.

8.8 Storage Warning!

Pull the mains plug out of the socket and ventilate the appliance and all connected pneumatic tools. Switch off the compressor and make sure that it is secured in such a way that it cannot be started up again by any unauthorized person.

Warning!

Store the compressor only in a dry location which is not accessible to unauthorized persons. Always store upright, never tilted!

Store the equipment and accessories in a dark and dry place at above freezing temperature. The ideal storage temperature is between 5 and 30 °C. Store the electric tool in its original packaging.

8.9 Transport

- Use the handle for transporting the compressor and use it to move the compressor about.
- Transport the equipment only by carrying it by the transport handle.
- Protect the equipment against unexpected knocks and vibrations.

8.10 Ordering replacement parts:

Please quote the following data when ordering replacement parts:

- Type of machine
- Article number of the machine
- Identification number of the machine
- Replacement part number of the part required

For our latest prices and information please go to www.Einhell-Service.com

The reprinting or reproduction by any other means, in whole or in part, of documentation and papers accompanying products is permitted only with the express consent of the Einhell Germany AG.

Subject to technical changes

9. Disposal and recycling

The equipment is supplied in packaging to prevent it from being damaged in transit. The raw materials in this packaging can be reused or recycled. The equipment and its accessories are made of various types of material, such as metal and plastic. Never place defective equipment in your household refuse. The equipment should be taken to a suitable collection center for proper disposal. If you do not know the whereabouts of such a collection point, you should ask in your local council offices.



For EU countries only

Never place any electric power tools in your household refuse.

To comply with European Directive 2012/19/EC concerning old electric and electronic equipment and its implementation in national laws, old electric power tools have to be separated from other waste and disposed of in an environment-friendly fashion, e.g. by taking to a recycling depot.

Recycling alternative to the return request:

As an alternative to returning the equipment to the manufacturer, the owner of the electrical equipment must make sure that the equipment is properly disposed of if he no longer wants to keep the equipment. The old equipment can be returned to a suitable collection point that will dispose of the equipment in accordance with the national recycling and waste disposal regulations. This does not apply to any accessories or aids without electrical components supplied with the old equipment.

- The product meets the requirements of EN 61000-3-11 and is subject to special connection conditions. This means that use of the product at any freely selectable connection point is not allowed.
- Given unfavorable conditions in the power supply the product can cause the voltage to fluctuate temporarily.
- The product is intended solely for use at connection points that
 - a) do not exceed a maximum permitted mains system impedance of $Z_{\text{sys}} = 0.098 + 0.062j$, or
 - b) have a continuous current-carrying capacity of the mains of at least 100 A per phase.
- As the user, you are required to ensure, in consultation with your electric power company if necessary, that the connection point at which you wish to operate the product meets one of the two requirements, a) or b), named above.

10. Possible causes of failure

Problem	Cause	Solution
The compressor does not start.	<ol style="list-style-type: none"> 1. No supply voltage. 2. Insufficient supply voltage. 3. Outside temperature is too low. 4. Motor is overheated. 	<ol style="list-style-type: none"> 1. Check the supply voltage, the power plug and the socket-outlet. 2. Make sure that the extension cable is not too long. Use an extension cable with large enough wires. 3. Never operate with an outside temperature of below +5° C. 4. Allow the motor to cool down. If necessary, remedy the cause of the overheating.
The compressor starts but there is no pressure.	<ol style="list-style-type: none"> 1. The non-return valve leaks. 2. The seals are damaged. 3. The drain plug for condensation water (11) leaks. 	<ol style="list-style-type: none"> 1. Have a service center replace the non-return valve. 2. Check the seals and have any damaged seals replaced by a service center. 3. Tighten the screw by hand. Check the seal on the screw and replace if necessary.
The compressor starts, pressure is shown on the pressure gauge, but the tools do not start.	<ol style="list-style-type: none"> 1. The hose connections have a leak. 2. A quick-lock coupling has a leak. 3. Insufficient pressure set on the pressure regulator. 	<ol style="list-style-type: none"> 1. Check the compressed air hose and tools and replace if necessary. 2. Check the quick-lock coupling and replace if necessary. 3. Increase the set pressure with the pressure regulator.



Service information

We have competent service partners in all countries named on the guarantee certificate whose contact details can also be found on the guarantee certificate. These partners will help you with all service requests such as repairs, spare and wearing part orders or the purchase of consumables.

Please note that the following parts of this product are subject to normal or natural wear and that the following parts are therefore also required for use as consumables.

Category	Example
Wear parts*	V-belt, air filter
Consumables*	
Missing parts	

* Not necessarily included in the scope of delivery!

In the effect of defects or faults, please register the problem on the internet at www.Einhell-Service.com. Please ensure that you provide a precise description of the problem and answer the following questions in all cases:

- Did the equipment work at all or was it defective from the beginning?
- Did you notice anything (symptom or defect) prior to the failure?
- What malfunction does the equipment have in your opinion (main symptom)? Describe this malfunction.



Warranty certificate

Dear Customer,

All of our products undergo strict quality checks to ensure that they reach you in perfect condition. In the unlikely event that your device develops a fault, please contact our service department at the address shown on this guarantee card. You can also contact us by telephone using the service number shown.

Please note the following terms under which guarantee claims can be made:

1. These guarantee terms apply to consumers only, i.e. natural persons intending to use this product neither for their commercial activities nor for any other self-employed activities. These warranty terms regulate additional warranty services, which the manufacturer mentioned below promises to buyers of its new products in addition to their statutory rights of guarantee. Your statutory guarantee claims are not affected by this guarantee. Our guarantee is free of charge to you.
2. The warranty services cover only defects due to material or manufacturing faults on a product which you have bought from the manufacturer mentioned below and are limited to either the rectification of said defects on the product or the replacement of the product, whichever we prefer.
Please note that our devices are not designed for use in commercial, trade or professional applications. A guarantee contract will not be created if the device has been used by commercial, trade or industrial business or has been exposed to similar stresses during the guarantee period.
3. The following are not covered by our guarantee:
 - Damage to the device caused by a failure to follow the assembly instructions or due to incorrect installation, a failure to follow the operating instructions (for example connecting it to an incorrect mains voltage or current type) or a failure to follow the maintenance and safety instructions or by exposing the device to abnormal environmental conditions or by lack of care and maintenance.
 - Damage to the device caused by abuse or incorrect use (for example overloading the device or the use of unapproved tools or accessories), ingress of foreign bodies into the device (such as sand, stones or dust, transport damage), the use of force or damage caused by external forces (for example by dropping it).
 - Damage to the device or parts of the device caused by normal or natural wear or tear or by normal use of the device.
4. The guarantee is valid for a period of 24 months starting from the purchase date of the device. Guarantee claims should be submitted before the end of the guarantee period within two weeks of the defect being noticed. No guarantee claims will be accepted after the end of the guarantee period. The original guarantee period remains applicable to the device even if repairs are carried out or parts are replaced. In such cases, the work performed or parts fitted will not result in an extension of the guarantee period, and no new guarantee will become active for the work performed or parts fitted. This also applies if an on-site service is used.
5. To make a claim under the guarantee, please register the defective device at: www.Einhell-Service.com. Please keep your bill of purchase or other proof of purchase for the new device. Devices that are returned without proof of purchase or without a rating plate shall not be covered by the guarantee, because appropriate identification will not be possible. If the defect is covered by our guarantee, then the item in question will either be repaired immediately and returned to you or we will send you a new replacement.

Of course, we are also happy offer a chargeable repair service for any defects which are not covered by the scope of this guarantee or for units which are no longer covered. To take advantage of this service, please send the device to our service address.

Also refer to the restrictions of this warranty concerning wear parts, consumables and missing parts as set out in the service information in these operating instructions.