

Einhell

PRESSITO

D	Originalbetriebsanleitung Hybrid-Kompressor	H	Eredeti használati utasítás Hibrid-kompresszor
GB	Original operating instructions Hybrid compressor	RO	Instrucțiuni de utilizare originale Compressor hibrid
F	Instructions d'origine Compresseur hybride	GR	Πρωτότυπες Οδηγίες χρήσης Υβριδικός συμπιεστής
I	Istruzioni per l'uso originali Compressore ibrido	P	Manual de instrucções original Compressor híbrido
DK/ N	Original betjeningsvejledning Hybrid-kompressor	HR/ BIH	Originalne upute za uporabu Hibridni kompresor
S	Original-bruksanvisning Hybrid-kompressor	RS	Originalna uputstva za upotrebu Hibridni kompresor
CZ	Originální návod k obsluze Hybridní kompresor	TR	Orjinal Kullanma Talimatı Hibrit kompresör
SK	Originálny návod na obsluhu Hybridný kompresor	PL	Instrukcja oryginalną Kompresor akumulatorowo- sieciorowy
NL	Originele handleiding Hybride compressor	RUS	Оригинальное руководство по эксплуатации Гибридный компрессор
E	Manual de instrucciones original Compressor híbrido		
FIN	Alkuperäiskäyttöohje Hybridikompressor		
SLO	Originalna navodila za uporabo Hibridni kompresor		

13  

Art.-Nr.: 40.204.60

I.-Nr.: 11017

1a

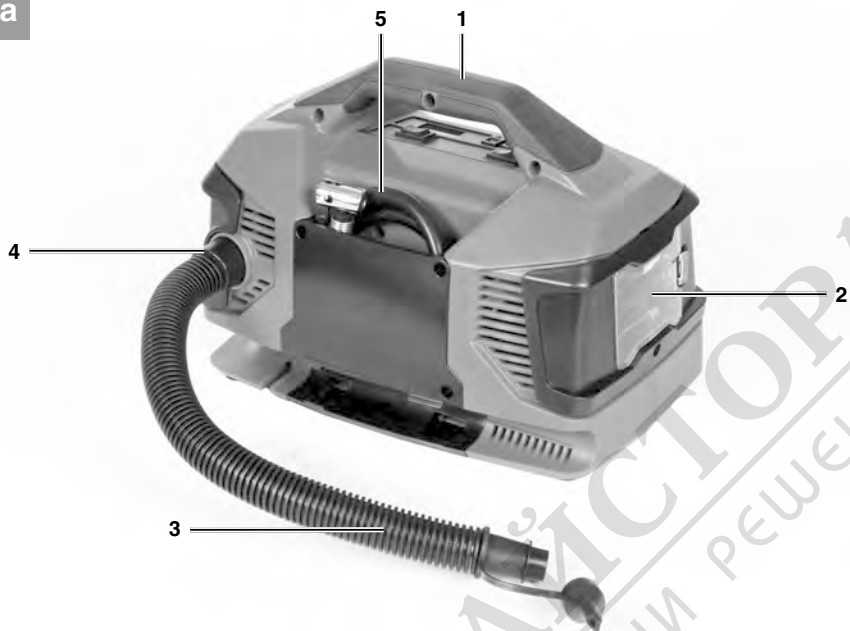

1b

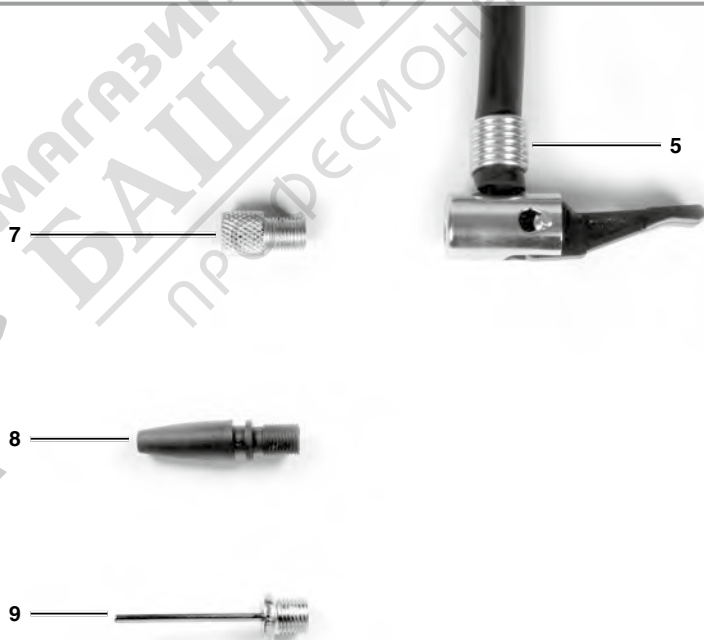

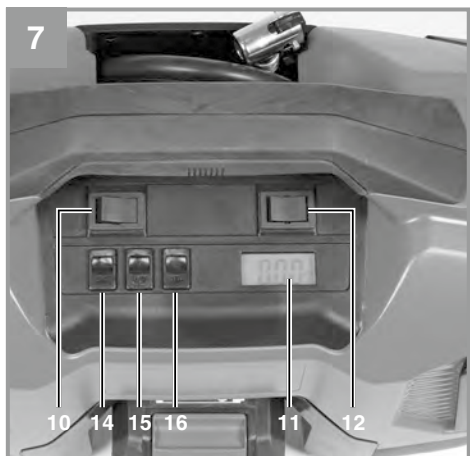
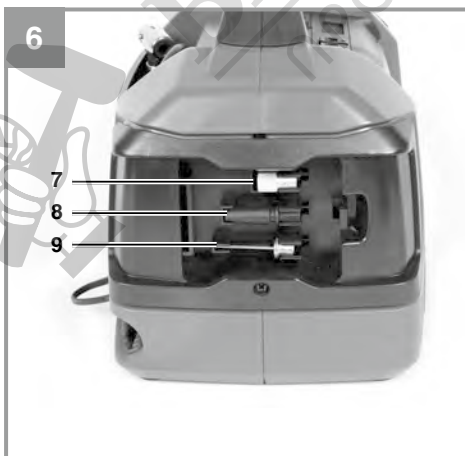
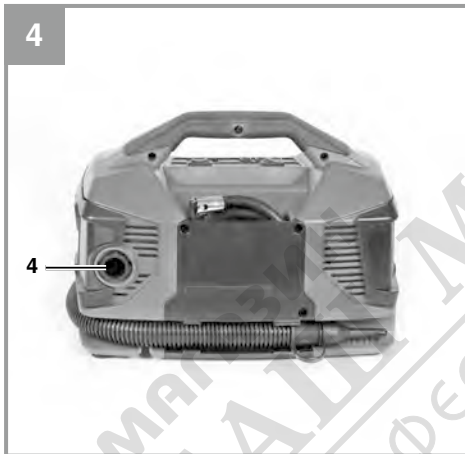
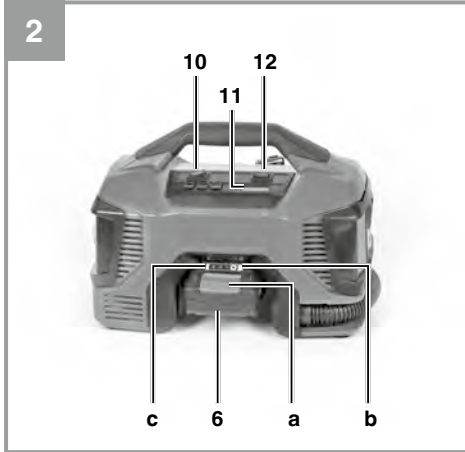

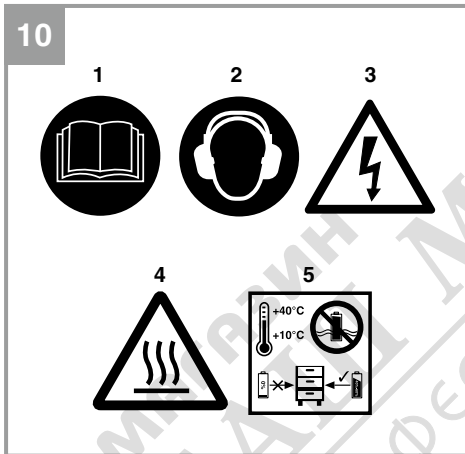
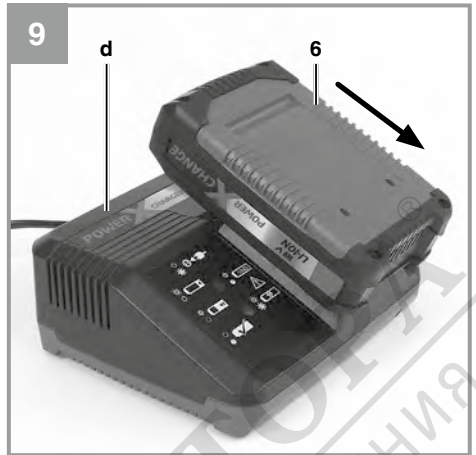
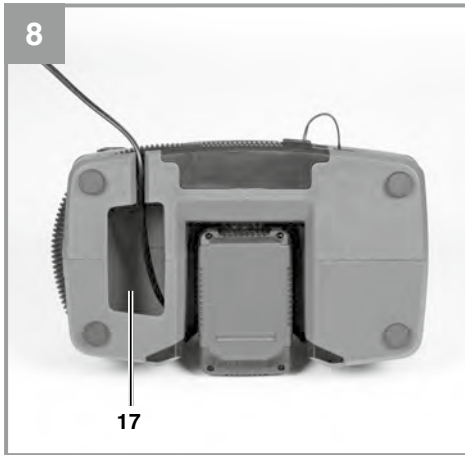

Danger!

When using the equipment, a few safety precautions must be observed to avoid injuries and damage. Please read the complete operating instructions and safety regulations with due care. Keep this manual in a safe place, so that the information is available at all times. If you give the equipment to any other person, hand over these operating instructions and safety regulations as well. We cannot accept any liability for damage or accidents which arise due to a failure to follow these instructions and the safety instructions.

Explanation of the symbols used (see Fig. 10)

1. **Danger!** - Read the operating instructions to reduce the risk of injury.
2. **Caution! Wear ear-muffs.** The impact of noise can cause damage to hearing.
3. **Beware of electrical voltage!**
4. **Beware of hot parts!**
5. Store the batteries only in dry rooms with an ambient temperature of +10°C to +40°C. Place only fully charged batteries in storage (charged at least 40%).

1. Safety regulations

The corresponding safety information can be found in the enclosed booklet.

Danger!**Read all safety regulations and instructions.**

Any errors made in following the safety regulations and instructions may result in an electric shock, fire and/or serious injury.

Keep all safety regulations and instructions in a safe place for future use.**2. Layout and items supplied****2.1 Layout (Fig. 1-8)**

- 1 Handle
- 2 Accessory storage compartment
- 3 Air hose
- 4 Air hose connection (blowing)
- 5 Compressed air hose with valve adapter
- 6 Battery pack (not supplied)
- 7 Bicycle adapter
- 8 Conical adapter
- 9 Adapter for ball valves
- 10 Selector switch for mains-powered mode/
battery-powered mode
- 11 Display

- 12 Selector switch for compressed air mode/
OFF/low-pressure blower mode
- 13 Air hose connection (suction)
- 14 "Reduce pressure" button
- 15 "Unit overpressure" button
- 16 "Increase pressure" button
- 17 Storage compartment for the power cable

2.2 Items supplied

Please check that the article is complete as specified in the scope of delivery. If parts are missing, please contact our service center or the sales outlet where you made your purchase at the latest within 5 working days after purchasing the product and upon presentation of a valid bill of purchase. Also, refer to the warranty table in the service information at the end of the operating instructions.

- Open the packaging and take out the equipment with care.
- Remove the packaging material and any packaging and/or transportation braces (if available).
- Check to see if all items are supplied.
- Inspect the equipment and accessories for transport damage.
- If possible, please keep the packaging until the end of the guarantee period.

Danger!

The equipment and packaging material are not toys. Do not let children play with plastic bags, foils or small parts. There is a danger of swallowing or suffocating!

- Air hose
- Bicycle adapter
- Conical adapter
- Adapter for ball valves
- Original operating instructions
- Safety instructions

3. Proper use

This device is intended for inflating car, motorcycle and bicycle tires as well as sports balls, water balls, air mattresses and other similar items.

In addition the device is also intended for suctioning volumes of air from objects with low pressure, such as water balls, air mattresses and other similar items.

This device is not suitable for tires with very large volumes, such as truck or tractor tires for example.

The equipment can be operated from the mains power supply using the power cable or alternatively in battery-powered mode using a suitable rechargeable battery.

The equipment does not have a charging functionality for the rechargeable battery.

The equipment is to be used only for its prescribed purpose. Any other use is deemed to be a case of misuse. The user / operator and not the manufacturer will be liable for any damage or injuries of any kind caused as a result of this.

Please note that our equipment has not been designed for use in commercial, trade or industrial applications. Our warranty will be voided if the machine is used in commercial, trade or industrial businesses or for equivalent purposes.

4. Technical data

Weight without battery approx. 2.2 kg
 Protection type IP X0
 Protection class II / 
 Length of compressed air hose approx. 71 cm
 Length of air hose approx. 31 cm

Data for mains-powered mode

Rated operating voltage and frequency
 (mains-powered) 220-240V ~ 50 Hz
 Rating (compressor compressed air) 90 W
 Max. operating pressure
 (compressor compressed air) 11 bar
 Theoretical suction rate
 (compressor compressed air) 21 liters/min
 Output for compressed air at 4 bar 10 l/min
 Output for compressed air at 7 bar 8 l/min
 Rating (low-pressure blower) 90 W
 Max. volumetric flow for suctioning
 (low-pressure blower): 380 l/min
 Max. volumetric flow for inflating
 (low-pressure blower): 400 l/min
 Compressor idling speed 3450 min⁻¹
 Blower idling speed 15000 min⁻¹

Data for operation with a rechargeable battery

Power supply (rechargeable battery) 18 V d.c.
 Max. operating pressure
 (compressor compressed air) 11 bar
 Theoretical suction rate
 (compressor compressed air) 21 liters/min
 Output for compressed air at 4 bar 9 l/min
 Output for compressed air at 7 bar 6 l/min
 Max. volumetric flow for suctioning
 (low-pressure blower): 370 l/min
 Max. volumetric flow for inflating
 (low-pressure blower): 390 l/min
 Compressor idling speed 3450 min⁻¹
 Blower idling speed 15000 min⁻¹

Danger!

Sound and vibration

The noise emission values were measured in accordance with EN ISO 3744.

L_{pA} sound pressure level 71.5 dB(A)
 K_{pA} uncertainty 3 dB
 L_{WA} sound power level 82.5 dB(A)
 K_{WA} uncertainty 3 dB

Wear ear-muffs.

The impact of noise can cause damage to hearing.

Keep the noise emissions and vibrations to a minimum.

- Only use appliances which are in perfect working order.
- Service and clean the appliance regularly.
- Adapt your working style to suit the appliance.
- Do not overload the appliance.
- Have the appliance serviced whenever necessary.
- Switch the appliance off when it is not in use.

Caution!

Residual risks

Even if you use this electric power tool in accordance with instructions, certain residual risks cannot be ruled out. The following hazards may arise in connection with the equipment's construction and layout:

- Damage to hearing if no suitable ear protection is used.

Danger!

The electric power tool generates an electro-magnetic field during operation. Under certain circumstances this field may actively or passively impede medical implants. To reduce the risk of serious or fatal injuries, we recommend persons with medical implants to consult their doctor and the manufacturer of the medical implant prior to using the equipment.

5. Before using the equipment

Before you connect the equipment to the power supply make sure that the data on the rating plate are identical to the supply voltage (if operating from the mains power supply).

Before you connect the equipment to the power supply make sure that the data on the rating plate are identical to the data for the rechargeable battery (if using a rechargeable battery for operation).

- Check the equipment for damage which may have occurred in transit. Report any damage immediately to the transport company which was used to deliver the compressor.
- Make sure that the intake air is dry and dust-free.
- Do not install the compressor in a damp or wet room.
- The compressor may only be used in suitable rooms (with good ventilation and an ambient temperature from +5 °C to 40 °C). There must be no dust, acids, vapors, explosive gases or inflammable gases in the room.
- The compressor is designed to be used in dry rooms. It is prohibited to use the compressor in areas where work is conducted with sprayed water.
- Operate the equipment only on a firm, level surface.

Warning! When using the equipment to inflate objects, check the information and safety instructions provided by the manufacturer.

5.1 Charging the LI battery pack (Fig. 2, 9)

1. Remove the battery pack (6) from the handle, pressing the pushlock button (a) downwards to do so.
2. Check that your mains voltage is the same as that marked on the rating plate of the battery

charger. Insert the power plug of the charger (d) into the socket outlet. The green LED will then begin to flash.

3. Push the battery pack (6) onto the battery charger (d).

In section 10 (Charger indicator) you will find a table with an explanation of the LED indicator on the charger.

If the battery pack fails to charge, check for the following:

- voltage at the power socket
- whether there is good contact at the charging contacts of the charging unit.

If the battery pack still fails to charge, send

- the charger and charging adapter
 - and the battery pack
- to our customer service center.

To ensure that items are properly packaged and delivered when you send them to us, please contact our customer service or the point of sale at which the equipment was purchased.

When shipping or disposing of batteries and cordless tools, always ensure that they are packed individually in plastic bags to prevent short circuits and fires.

To ensure that the battery pack provides long service, you should take care to recharge it promptly. You must recharge the battery pack when you notice that the performance of the device drops. Never allow the battery pack to become fully discharged. This will cause it to develop a defect.

5.2 Battery capacity indicator (Fig. 2)

Press the button for the battery capacity indicator (b). The battery capacity indicator (c) will indicate the charge status of the battery by means of 3 LEDs.

All 3 LEDs are lit:

The battery is fully charged.

2 or 1 LED(s) are lit:

The battery has an adequate remaining charge.

1 LED blinks:

The battery is empty, recharge the battery.

All LEDs blink:

The battery temperature is too low. Remove the battery from the equipment, keep it at room temperature for one day. If the fault reoccurs, this means that the rechargeable battery has undergone exhaustive discharge and is defective. Remove the battery from the equipment. Never use or charge a defective battery.

6. Operation**6.1 Changing between mains/battery operation and compressor compressed air/low-pressure blower operation (Fig. 7)**

To change over between mains-powered and battery-powered operation, press the selector switch (10):

- DC/switch to the right:
- The equipment will be supplied with power from the rechargeable battery.
- AC/switch to the left:
- The equipment will be supplied with power from the power cable.
- To change over between compressed air and low-pressure operation, press the selector switch (12):
- Switch to the left: Compressed air operation
- Switch in the middle: OFF
- Switch to the right: Low-pressure operation

6.2 Compressor compressed air operation (Fig. 1a, 1b, 2, 7)

- To inflate objects with compressed air, use the compressed air hose (5).
- Connect the adapter of the compressed air hose to the object you wish to inflate.
- Depending on what you are inflating, also use the adapters (7, 8, 9) or other adapters available from retail stores.
- The pressure at the compressed air hose will be displayed in the display (11).
The unit of the displayed pressure can be selected with the button (15). The pressure can be displayed in units of [bar], [PSI] or [kPa].
- The button (14) allows the desired pressure to be reduced.
- The button (16) allows the desired pressure to be increased.
- Switch on the equipment by moving the selector switch (12) to the compressed air operation position (see 6.1.).
- The compressor will then pump until the pre-set pressure on the display is reached, then it

will switch off.

- Warning! Observe the information supplied by the tire manufacturer and the vehicle manufacturer relating to the recommended tire pressure.
- Warning! This equipment is not calibrated! For a calibrated measurement value, check the actual tire pressure using a calibrated meter after you have inflated the tires yourself, e.g. at a petrol station.
- Just before it is switched off, the pressure which is shown in the display can be 0.05 – 0.2 bar higher than the preselected pressure, because of overpressure in the air hose.
- Allow the compressor to cool down for about 5 minutes after every 5 minutes of operation in order to prevent overheating.

6.3 Low-pressure blower operation (Fig. 1a, 3, 4)**6.3.1 Suctioning air (Fig. 3, 7)**

- To suction out objects with a large volume until they are empty (e.g. deflating an air mattress, etc.), connect the air hose (3) to the extractor connection (13).
- Connect the air hose to the object you wish to deflate.
- Switch on the equipment by moving the selector switch (12) to the low-pressure operation position (see 6.1.).
- Switch off the equipment once the object has been sufficiently deflated.

6.3.2 Inflating (Fig. 4, 7)

Warning! When using the equipment to inflate objects, check the information and safety instructions provided by the manufacturer.

- To inflate objects with a large volume (e.g. inflating an air mattress, etc.), connect the air hose (3) to the inflating connection (4).
- Connect the air hose to the object you wish to inflate.
- Switch on the equipment by moving the selector switch (12) to the low-pressure operation position (see 6.1.).
- Switch off the equipment once the object has been sufficiently inflated.

7. Replacing the power cable

Danger!

If the power cable for this equipment is damaged, it must be replaced by the manufacturer or its after-sales service or similarly trained personnel to avoid danger.

8. Cleaning, maintenance and ordering of spare parts

Danger!

Always take the battery out of the equipment and pull out the power plug before starting any cleaning work.

8.1 Cleaning

- Keep all safety devices, air vents and the motor housing free of dirt and dust as far as possible. Wipe the equipment with a clean cloth or blow it with compressed air at low pressure.
- We recommend that you clean the device immediately each time you have finished using it.
- Clean the equipment regularly with a moist cloth and some soft soap. Do not use cleaning agents or solvents; these could attack the plastic parts of the equipment. Ensure that no water can seep into the device. The ingress of water into an electric tool increases the risk of an electric shock.

8.2 Maintenance

There are no parts inside the equipment which require additional maintenance.

8.3 Ordering spare parts and accessories

Please provide the following information when ordering spare parts:

- Type of unit
- Article number of the unit
- ID number of the unit
- Spare part number of the required spare part

For our latest prices and information please go to www.Einhell-Service.com

9. Disposal and recycling

The equipment is supplied in packaging to prevent it from being damaged in transit. The raw materials in this packaging can be reused or recycled. The equipment and its accessories are made of various types of material, such as metal and plastic. Never place defective equipment in your household refuse. The equipment should be taken to a suitable collection center for proper disposal. If you do not know the whereabouts of such a collection point, you should ask in your local council offices.

10. Storage

Store the equipment and accessories in a dark and dry place at above freezing temperature. The ideal storage temperature is between 5 and 30 °C. Store the electric tool in its original packaging.



Tip! For good results we recommend high-quality accessories from  !
www.kwb.eu
welcome@kwb.eu

11. Charger indicator

Indicator status		Explanations and actions
Red LED	Green LED	
Off	Flashing	<p>Ready for use The charger is connected to the mains and is ready for use; there is no battery pack in the charger</p>
On	Off	<p>Charging The charger is charging the battery pack in quick charge mode. The charging times are shown directly on the charger. Important! The actual charging times may vary slightly from the stated charging times depending on the existing battery charge.</p>
Off	On	<p>The battery is charged and ready for use. The unit then changes over to gentle charging mode until the battery is fully charged. To do this, leave the rechargeable battery on the charger for approx. 15 minutes longer. Action: Take the battery pack out of the charger. Disconnect the charger from the mains supply.</p>
Flashing	Off	<p>Adapted charging The charger is in gentle charging mode. For safety reasons the charging is performed less quickly and takes more time. The reasons can be: - The rechargeable battery has not been used for a very long time. - The battery temperature is outside the ideal range. Action: Wait for the charging to be completed; you can still continue to charge the battery pack.</p>
Flashing	Flashing	<p>Fault Charging is no longer possible. The battery pack is defective. Action: Never charge a defective battery pack. Take the battery pack out of the charger.</p>
On	On	<p>Temperature fault The battery pack is too hot (e.g. due to direct sunshine) or too cold (below 0° C). Action: Remove the battery pack and keep it at room temperature (approx. 20° C) for one day .</p>



For EU countries only

Never place any electric power tools in your household refuse.

To comply with European Directive 2012/19/EC concerning old electric and electronic equipment and its implementation in national laws, old electric power tools have to be separated from other waste and disposed of in an environment-friendly fashion, e.g. by taking to a recycling depot.

Recycling alternative to the return request:

As an alternative to returning the equipment to the manufacturer, the owner of the electrical equipment must make sure that the equipment is properly disposed of if he no longer wants to keep the equipment. The old equipment can be returned to a suitable collection point that will dispose of the equipment in accordance with the national recycling and waste disposal regulations. This does not apply to any accessories or aids without electrical components supplied with the old equipment.

The reprinting or reproduction by any other means, in whole or in part, of documentation and papers accompanying products is permitted only with the express consent of the Einhell Germany AG.

Subject to technical changes



Service information

We have competent service partners in all countries named on the guarantee certificate whose contact details can also be found on the guarantee certificate. These partners will help you with all service requests such as repairs, spare and wearing part orders or the purchase of consumables.

Please note that the following parts of this product are subject to normal or natural wear and that the following parts are therefore also required for use as consumables.

Category	Example
Wear parts*	Battery
Consumables*	
Missing parts	

* Not necessarily included in the scope of delivery!

In the effect of defects or faults, please register the problem on the internet at www.Einhell-Service.com. Please ensure that you provide a precise description of the problem and answer the following questions in all cases:

- Did the equipment work at all or was it defective from the beginning?
- Did you notice anything (symptom or defect) prior to the failure?
- What malfunction does the equipment have in your opinion (main symptom)? Describe this malfunction.



Warranty certificate

Dear Customer,

All of our products undergo strict quality checks to ensure that they reach you in perfect condition. In the unlikely event that your device develops a fault, please contact our service department at the address shown on this guarantee card. You can also contact us by telephone using the service number shown. Please note the following terms under which guarantee claims can be made:

1. These guarantee terms apply to consumers only, i.e. natural persons intending to use this product neither for their commercial activities nor for any other self-employed activities. These warranty terms regulate additional warranty services, which the manufacturer mentioned below promises to buyers of its new products in addition to their statutory rights of guarantee. Your statutory guarantee claims are not affected by this guarantee. Our guarantee is free of charge to you.
2. The warranty services cover only defects due to material or manufacturing faults on a product which you have bought from the manufacturer mentioned below and are limited to either the rectification of said defects on the product or the replacement of the product, whichever we prefer.
Please note that our devices are not designed for use in commercial, trade or professional applications. A guarantee contract will not be created if the device has been used by commercial, trade or industrial business or has been exposed to similar stresses during the guarantee period.
3. The following are not covered by our guarantee:
 - Damage to the device caused by a failure to follow the assembly instructions or due to incorrect installation, a failure to follow the operating instructions (for example connecting it to an incorrect mains voltage or current type) or a failure to follow the maintenance and safety instructions or by exposing the device to abnormal environmental conditions or by lack of care and maintenance.
 - Damage to the device caused by abuse or incorrect use (for example overloading the device or the use of unapproved tools or accessories), ingress of foreign bodies into the device (such as sand, stones or dust, transport damage), the use of force or damage caused by external forces (for example by dropping it).
 - Damage to the device or parts of the device caused by normal or natural wear or tear or by normal use of the device.
4. The guarantee is valid for a period of 24 months starting from the purchase date of the device. Guarantee claims should be submitted before the end of the guarantee period within two weeks of the defect being noticed. No guarantee claims will be accepted after the end of the guarantee period. The original guarantee period remains applicable to the device even if repairs are carried out or parts are replaced. In such cases, the work performed or parts fitted will not result in an extension of the guarantee period, and no new guarantee will become active for the work performed or parts fitted. This also applies if an on-site service is used.
5. To make a claim under the guarantee, please register the defective device at: www.Einhell-Service.com. Please keep your bill of purchase or other proof of purchase for the new device. Devices that are returned without proof of purchase or without a rating plate shall not be covered by the guarantee, because appropriate identification will not be possible. If the defect is covered by our guarantee, then the item in question will either be repaired immediately and returned to you or we will send you a new replacement.

Of course, we are also happy offer a chargeable repair service for any defects which are not covered by the scope of this guarantee or for units which are no longer covered. To take advantage of this service, please send the device to our service address.

Also refer to the restrictions of this warranty concerning wear parts, consumables and missing parts as set out in the service information in these operating instructions.