

Einhell

TC-PG 35/E5

D	Originalbetriebsanleitung Stromerzeuger	NL	Originele handleiding Elektriciteitsgenerator
GB	Original operating instructions Power Generator	E	Manual de instrucciones original Grupo Electrogenero
F	Instructions d'origine Générateur de courant	FIN	Alkuperäiskäyttöohje Generaattori
I	Istruzioni per l'uso originali Generatore di corrente	RUS	Оригинальное руководство по эксплуатации электрический генератор
DK/ N	Original betjeningsvejledning Generator	SLO	Originalna navodila za uporabo Električni generator
S	Original-bruksanvisning Strömgenerator	H	Eredeti használati utasítás Áramfejlesztő
CZ	Originální návod k obsluze Generátor	RO	Instrucțiuni de utilizare originale Generator de curent
SK	Originálny návod na obsluhu Elektrický generátor	GR	Πρωτότυπες Οδηγίες χρήσης Γεννήτρια



Art.-Nr.: 41.525.51

I.-Nr.: 11019

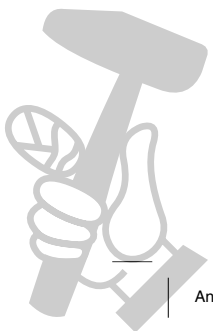
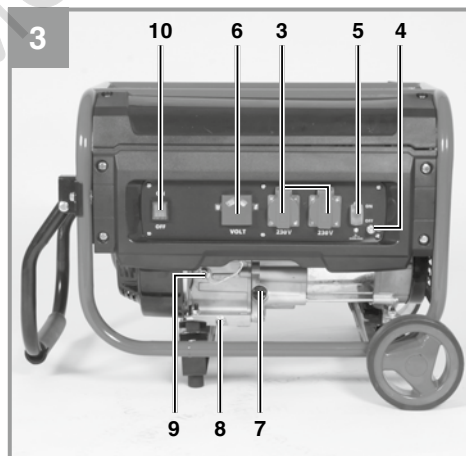
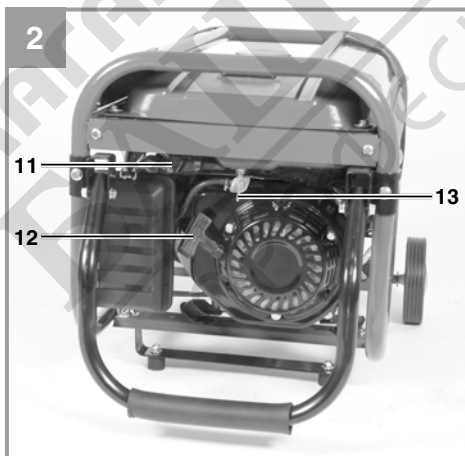

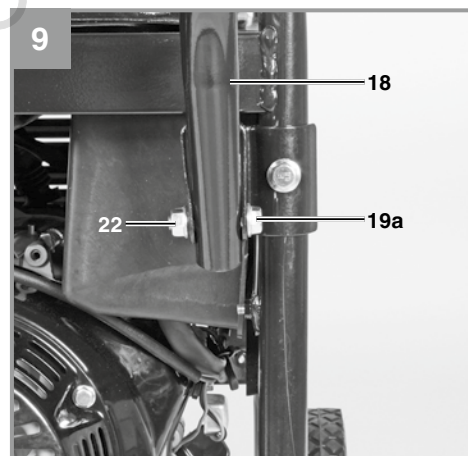
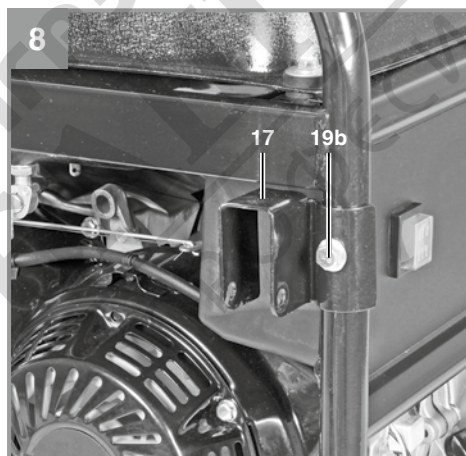
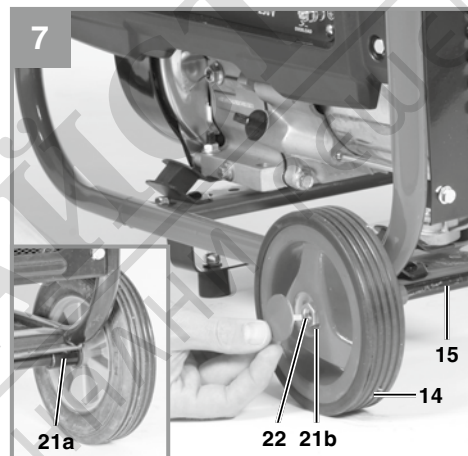
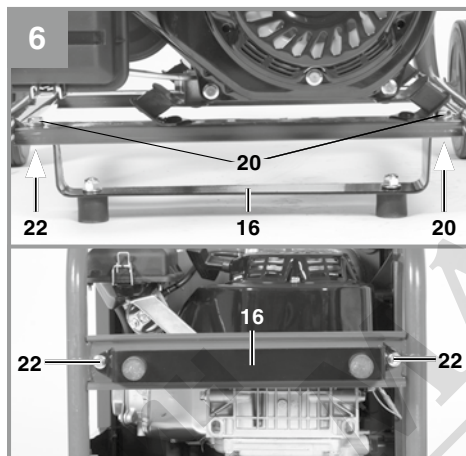
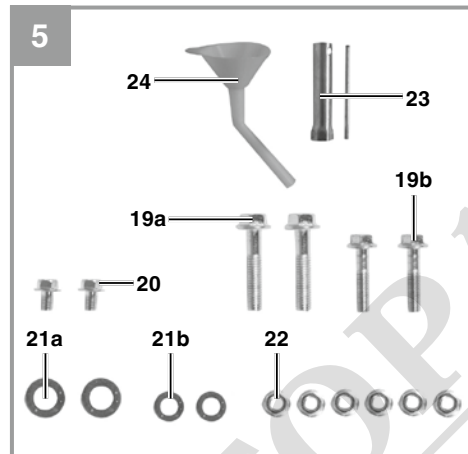
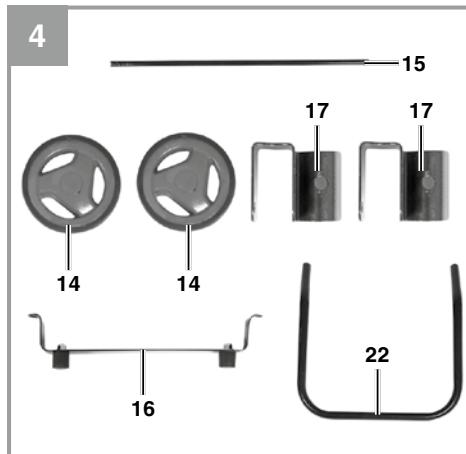

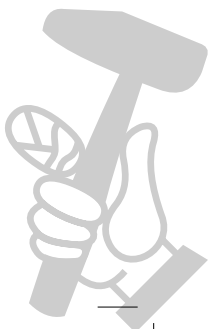
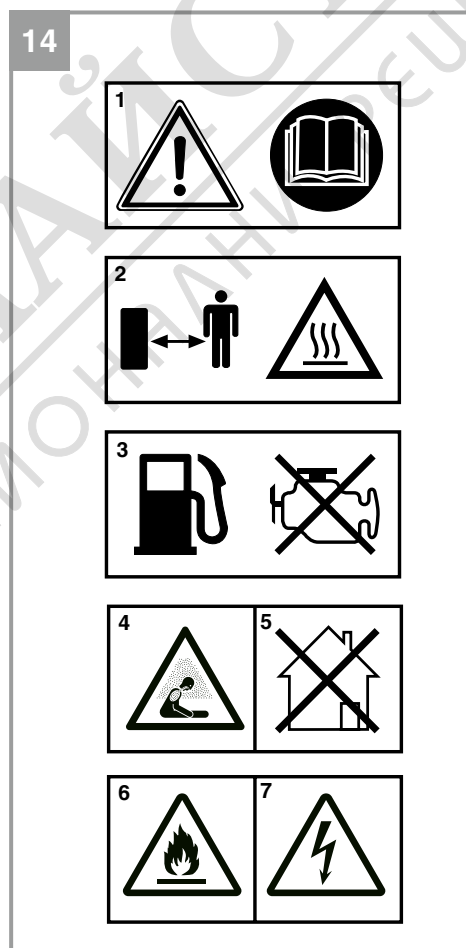
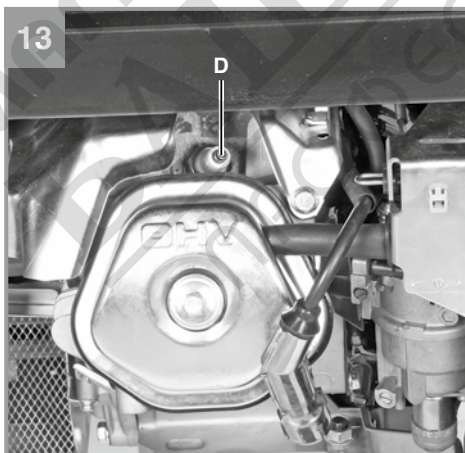
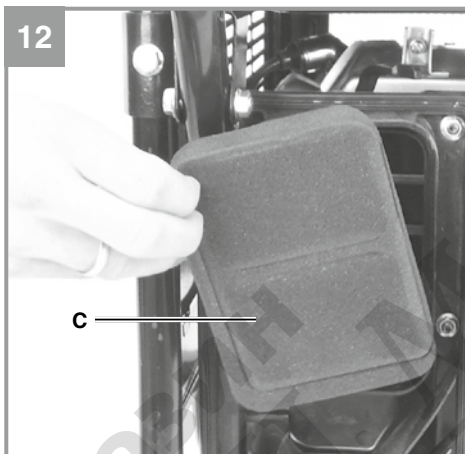
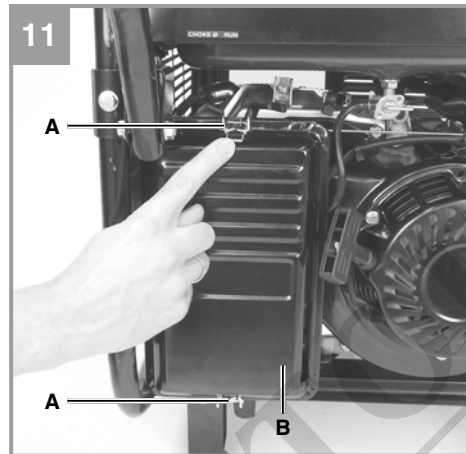
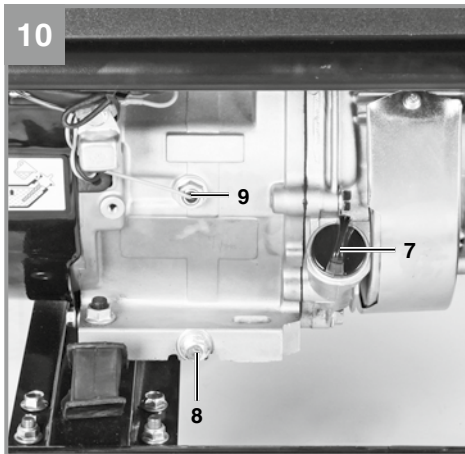

Danger!

When using the equipment, a few safety precautions must be observed to avoid injuries and damage. Please read the complete operating instructions and safety regulations with due care. Keep this manual in a safe place, so that the information is available at all times. If you give the equipment to any other person, hand over these operating instructions and safety regulations as well. We cannot accept any liability for damage or accidents which arise due to a failure to follow these instructions and the safety instructions.

Explanation of the warning signs on the machine (Fig. 14)

1. Danger! Read the operating instructions.
2. Warning! Hot parts. Keep your distance.
3. Danger! Switch off the engine before refueling.
4. Danger! The exhaust gases from the generator are toxic. Risk of suffocation.
5. Danger! Never operate in non-ventilated rooms.
6. Beware of inflammable materials.
7. Beware of electrical voltage.

1. Safety regulations**Danger!****Read all safety regulations and instructions.**

Any errors made in following the safety regulations and instructions may result in an electric shock, fire and/or serious injury.

Keep all safety regulations and instructions in a safe place for future use.

- No changes may be made to the generator.
- Only original parts may be used for maintenance and accessories.
- Important: Danger of poisoning, do not inhale emissions.
- Children are to be kept away from the generator.
- Important: Risk of burns. Do not touch the exhaust system or drive unit.
- Wear suitable ear protection when in the vicinity of the equipment.
- Important: Petrol and petrol fumes are highly combustible or explosive.
- Never operate the generator in non-ventilated rooms or in easily inflammable adjacency. When operating the generator in rooms with good ventilation, the exhaust gases must be channeled directly outdoors through an

exhaust hose. Important: Toxic exhaust gases can escape despite the exhaust hose. Due to the fire hazard, never direct the exhaust hose towards inflammable materials.

- Risk of explosion: Never operate the generator in rooms with combustible materials.
- The speed preset by the manufacturer is not allowed to be changed. The generator or connected equipment may be damaged.
- Secure the generator against shifting and toppling during transport.
- Place the generator at least 1m away from buildings and the equipment connected to it.
- Place the generator in a secure, level position. Do not turn, tip or change the generator's position while it is working.
- Always switch off the engine when transporting and refueling the generator.
- Make sure that when you refuel the generator no fuel is spilt on the engine or exhaust pipe.
- Never operate the generator in rain or snow.
- Never touch the generator with wet hands.
- Guard against electric danger. When working outdoors, use only extension cables that are approved for outdoor use and which are marked accordingly (H07RN..).
- If you use extension cables or mobile distribution networks, the resistance value must not exceed 1.5 Ω . As a reference value, cables with a cross-section of 1.5 mm² should not be any longer than 60 m in length, and cables with a cross-section of 2.5 mm² should not be any longer than 100 m.
- No changes may be made to the settings of the motor or generator.
- Repairs and adjustment work may only be carried out by authorized trained personnel. Do not refuel or empty the tank near open lights, fire or sparks. Do not smoke!
- Do not touch any mechanically driven or hot parts. Do not remove the safety guards.
- Do not expose the tools to damp or dust. Permissible ambient temperature – 10 to + 40 °C, max. altitude above sea level 1000 m, relative humidity: 90 % (non-condensing)
- The generator is driven by a combustion engine, which produces heat in the area of the exhaust (on the opposite side of the sockets) and the exhaust outlet. You should therefore keep clear of these surfaces because of risk of skin burns.
- Fuel is combustible and highly flammable. Do not fill up while in operation.
- Some parts of the reciprocating internal combustion engine are hot and can cause burns.

The warnings on the generating set must be observed.

- If it is installed in ventilated rooms, the additional requirements relating to protection against fire and explosions must be observed.
- Before use, the generating set and its electrical equipment (including cables and plug connections) need to be checked to ensure that they are not faulty.
- The generating set must never be connected to any other source of electricity such as the electricity supply from a power supply company. In special cases where a back-up connection to existing electrical systems is intended, this may only be carried out by a qualified electrician who takes account of the differences between the operated equipment used by the public power grid and that used for the operation of the generating set. It is a requirement of this part of ISO 8528 that the differences must be specified in the instructions.
- Given the high mechanical loads, only hard-wearing rubber-insulated cables (in accordance with IEC 60245-4) or equivalent equipment should be used.
- Warning! Observe the regulations on electrical safety applicable to the area in which the generating sets are used.
- Warning! Observe the requirements to be met and precautions to be taken if restoring power to a system using generating sets in dependency on the safety measures for the system and the applicable directives and guidelines.
- Generating sets should only be used up to their nominal power rating under the rated ambient conditions. If the generating set is used under conditions which do not meet the reference conditions required by ISO 8528-8 and if this impairs the cooling of the engine or the generator, e.g. as a result of operation in restricted areas, the output must be reduced. Information should be provided to inform the user about the reduction in output required as a consequence of higher temperatures, installation height and air humidity in comparison to the reference conditions.
- The values quoted in the technical data for sound power level (LWA) and sound pressure level (LWM) are emission values and not necessarily reliable workplace values. As there is a correlation between emission and immission levels, the values are not a reliable basis for deciding on any additional precautions which may be needed. Factors influencing

the actual user immission level include the properties of the work area, other sound sources etc., the number of machines and other processes in the vicinity, as well as the time span in which the operator is subjected to the noise. Also, the permitted immission level can vary from country to country. Nevertheless, with this information the user is able to make a better assessment of the dangers and risks involved.

- Never use a faulty or damaged electrical equipment (this also applies to extension cables and plug connections).
- Electric supply cables and connected equipment must be in perfect condition.
- The generator is to be operated only with equipment whose voltage specifications conform with the generator's output voltage.
- Never connect the generator to the power supply (socket-outlet).
- Keep the cable length to the consumer as short as possible.
- Dispose of soiled maintenance material and operating materials at the appropriate collection point.
- Recycle packaging material, metal and plastics.

2. Layout and items supplied

2.1 Layout (Fig. 1-5)

- 1 Tank indicator
- 2 Tank cover
- 3 2 x 230 V~ socket-outlets
- 4 Earth connection
- 5 Safety tripping element 230 V
- 6 Voltmeter
- 7 Oil filler screw
- 8 Oil drainage screw
- 9 Oil shortage cut-out
- 10 On/Off switch
- 11 Choke lever
- 12 Reversing starter
- 13 Petrol cock
- 14 Wheels
- 15 Axle
- 16 Foot
- 17 Push bar holder
- 18 Push bar
- 19a Screws size M8x40
- 19b Screws size M8x25
- 20 Screws size M8x16
- 21a Washers for wheels (inside)

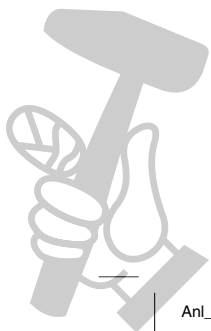

- 21b Washers for wheels (outside)
- 22 Nuts size M8
- 23 Spark plug wrench
- 24 Oil filler funnel

2.2 Items supplied

Please check that the article is complete as specified in the scope of delivery. If parts are missing, please contact our service center or the sales outlet where you made your purchase at the latest within 5 working days after purchasing the product and upon presentation of a valid bill of purchase. Also, refer to the warranty table in the service information at the end of the operating instructions.

- Open the packaging and take out the equipment with care.
- Remove the packaging material and any packaging and/or transportation braces (if available).
- Check to see if all items are supplied.
- Inspect the equipment and accessories for transport damage.
- If possible, please keep the packaging until the end of the guarantee period.

Danger!

The equipment and packaging material are not toys. Do not let children play with plastic bags, foils or small parts. There is a danger of swallowing or suffocating!

- Original operating instructions

3. Proper use

The device is designed for applications operated with a 230 V alternating current source. Be sure to observe the restrictions in the safety instructions.

The generator is intended to provide electric tools and light sources with electricity.

When using the device with household appliances, please check their suitability in accordance with the relevant manufacturer's instructions. In case of doubt, ask an authorized dealer of the respective appliance.

The equipment is to be used only for its prescribed purpose. Any other use is deemed to be a case of misuse. The user / operator and not the manufacturer will be liable for any damage or injuries of any kind caused as a result of this.

Please note that our equipment has not been designed for use in commercial, trade or industrial applications. Our warranty will be voided if the machine is used in commercial, trade or industrial businesses or for equivalent purposes.

4. Technical data

Generator	Synchronous
Protection type:	IP 23M
Continuous rated power P_{rated} (S1):	2600 W/230 V~
Maximum power P_{max} (S2 5 min):	2800 W/230 V~
Maximum power P_{max} (2 min):	3100 W/230 V~
Rated voltage U_{rated} :	2 x 230 V~
Rated current I_{rated} :	11.3 A (230V~)
Frequency F_{rated} :	50 Hz
Drive engine design:	4-stroke, air-cooled
Displacement:	208 cm ³
Max. power:	4.1 kW / 5.6 hp
Fuel:	normal unleaded petrol (E10)
Tank capacity:	15 l
Engine oil:	ca. 0.6 l
Consumption at 2/3 load:	approx. 1.5 l/h
Weight:	42 kg
Sound pressure level L_{pA} :	74.1 dB(A)
Sound power level L_{WA} : K uncertainty	96 dB (A)/2.07 dB(A)
Power factor $\cos \varphi$:	1
Power class:	G1
Max. temperature:	40°C
Max. altitude (above mean sea level):	1000 m
Spark plug:	LGF7RTC

Operating mode S1 (continuous operation)

The machine can be continuously operated with the quoted power output.

Operating mode S2 (temporary operation)

The machine may be temporarily operated with the quoted power output. Afterwards the machine must be stopped for a while to prevent it from overheating.

5. Before starting the equipment

5.1 Assembly

- Assemble the foot, wheels and push bar as shown in Figures 6-9.
- Assemble all parts before filling in fuel and oil in order to prevent the fluids from leaking out.
- To mount the wheels, first slide the axle through the mountings on the bottom of the generator and fit the wheels as shown on Figure 7.

5.2 Electrical safety:

- Electric supply cables and connected equipment must be in perfect condition.
- The generator is to be operated only with equipment whose voltage specifications conform with the generator's output voltage.
- Never connect the generator to the power supply (socket-outlet).
- Keep the cable length to the consumer as short as possible.

5.3 Environmental protection

- Dispose of soiled maintenance material and operating materials at the appropriate collection point.
- Recycle packaging material, metal and plastics.

5.4 Connecting to earth

The housing is allowed to be connected to earth in order to discharge static electricity. To do this, connect one end of a cable to the earth connection on the generator (Fig. 4) and the other end to an external earth (for example an earthing rod).

6. Operation

Important! You must fill up with engine oil and fuel before you can start the engine.

- Check the fuel level and top it up if necessary
- Make sure that the generator has sufficient ventilation
- Make sure that the ignition cable is secured to the spark plug
- Inspect the immediate vicinity of the generator
- Disconnect any electrical equipment which may already be connected to the generator

6.1 Starting the engine

- Open the petrol cock (13) by turning it down
- Move the ON/OFF switch (10) to position „ON“ with the key.
- Move the choke lever (11) to position IØI.
- Start the engine with the reversing starter (12) by pulling the handle forcefully. If the engine does not start, pull the handle again.
- Push the choke lever (11) back again after the engine has started.

Important!

When starting with the reserve starter, the motor may recoil suddenly as it starts up, resulting in hand injuries. Wear protective gloves when starting the equipment.

6.2 Connecting consumers to the generator

- Connect the equipment you want to use to the 230 V~sockets (3).

Important: These sockets may be loaded continuously (S1) with 2600W and temporarily (S2) for a maximum of 5 minutes with 2800 W or for a maximum of 2 minutes (with a cold motor) with 3100W.

- The generator is suitable for 230 V~ AC appliances only.
- Do not connect the generator to the household mains system as this may result in damage to the generator itself or to other electrical appliances in your home.

Note: Some electrical appliances (power jigsaws, drills, etc.) may have a higher level of power consumption when used in difficult conditions.

Some electrical appliances (for example televisions, computers, etc.) must not be powered by a generator.

If in doubt, consult the manufacturer of your appliance.

6.3 Overload cut-out 2 x 230 V socket-outlets

Important! The generator is fitted with an overload cut-out.

This shuts down the sockets (3). You can restart the sockets (3) by pressing the overload cut-out (5).

Important! If this happens, reduce the electric power you are taking from the generator or remove any defective connected appliances.

Important! Defective overload cut-outs must be replaced only by overload cut-outs of identical

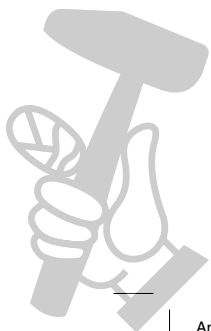

design and with the same performance data. If repairs are necessary, please contact your customer service center.

6.4 Switching off the engine

- Before you switch off the generator, allow it to run briefly with no consumers so that it can „cool down”
- Move the ON/OFF switch (10) to position „OFF” with the key.
- Close the petrol cock

7. Cleaning, maintenance, storage and ordering of spare parts

Switch off the motor and pull the spark plug boot from the spark plug before doing any cleaning and maintenance work on the equipment.

Notice! Switch off the machine immediately and contact your service station:

- In the event of unusual vibrations or noise
- If the engine appears to be overloaded or misfires

7.1 Cleaning

- Keep all safety devices, air vents and the motor housing free of dirt and dust as far as possible. Wipe the equipment with a clean cloth or blow it with compressed air at low pressure.
- We recommend that you clean the device immediately each time you have finished using it.
- Clean the equipment regularly with a moist cloth and some soft soap. Do not use cleaning agents or solvents; these could attack the plastic parts of the equipment. Ensure that no water can seep into the device.

7.2 Air filter

In this connection, please also read the service information.

- Clean the air filter at regular intervals, and replace it if necessary.
- Open both clips (Fig. 11/A) and remove the air filter cover (Fig. 11/B).
- Remove the filter elements (Fig. 12/C)
- Do not use abrasive cleaning agents or petrol to clean the elements.
- Clean the elements by tapping them on a flat surface. In cases of stubborn dirt first clean with soapy water, then rinse with clear water

and air-dry.

- Assemble in reverse order

7.3. Spark plug

Check the spark plug for dirt and grime after 20 hours of operation and if necessary clean with a copper wire brush. Thereafter service the spark plug after every 50 hours of operation.

- Pull off the spark plug boot with a twist.
- Remove the spark plug (Fig. 13/D) with the supplied spark plug wrench.
- Assemble in reverse order

7.4 Changing the oil and checking the oil level (before using the machine)

The motor oil is best changed when the motor is at working temperature.

- Place the generator on a slightly inclined surface so that the oil drain plug is at the lower end.
- Open the oil filler plug.
- Open the oil drain plug and let the hot engine oil drain out into a drip tray.
- After the old oil has drained out, close the oil drain plug and place the generator on a level surface again
- Fill in engine oil up to the top mark on the oil dip stick.
- Important: Do not screw the dipstick in to check the oil level, simply insert it up to the thread.
- Dispose of the waste oil properly.

7.5 Automatic oil cut-out

The automatic oil cut-out responds if there is too little oil in the engine. In this case it will not be possible to start the engine or it will cut out automatically after a short period of time. It cannot be started again until the engine oil has been topped up (see point 7.4).

7.6 Maintenance

- There are no parts inside the equipment which require additional maintenance.

7.7 Storage

- Leave the machine to cool (approx. 5 minutes).
- Clean the exterior housing of the machine.
- Store the machine in a cold, dry place where it is out of the reach of ignition sources and inflammable substances.

7.8 Ordering replacement parts:

Please quote the following data when ordering replacement parts:

- Type of machine
- Article number of the machine
- Identification number of the machine
- Replacement part number of the part required

For our latest prices and information please go to www.isc-gmbh.info

8. Disposal and recycling

The equipment is supplied in packaging to prevent it from being damaged in transit. The raw materials in this packaging can be reused or recycled. The equipment and its accessories are made of various types of material, such as metal and plastic. Never place defective equipment in your household refuse. The equipment should be taken to a suitable collection center for proper disposal. If you do not know the whereabouts of such a collection point, you should ask in your local council offices.

9. Transportation

- Use the handle for transporting the generator and use it to move the generator about.
- Transport the equipment only by carrying it by the transport handle.
- Protect the equipment against unexpected knocks and vibrations.

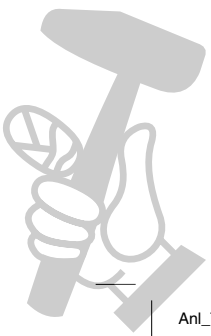

10. Troubleshooting

Fault	Mögliche Ursache	Behebung
Engine does not start	Automatic oil cut-out has not responded	Check oil level, top up engine oil
	Spark plug fouled	Clean or replace spark plug (electrode spacing 0.6 mm)
	No fuel	Refuel / have the petrol cock checked
Generator has too little or no voltage	Controller or capacitor defective	Contact your dealer
	Overcurrent circuit-breaker has triggered	Actuate the circuit-breaker and reduce the consumers
	Air filter dirty	Clean or replace the filter

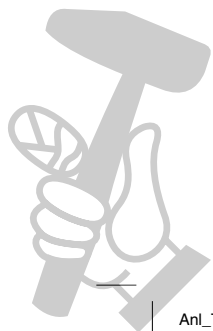



For EU countries only

Never place any electric power tools in your household refuse.

To comply with European Directive 2012/19/EC concerning old electric and electronic equipment and its implementation in national laws, old electric power tools have to be separated from other waste and disposed of in an environment-friendly fashion, e.g. by taking to a recycling depot.

Recycling alternative to the return request:

As an alternative to returning the equipment to the manufacturer, the owner of the electrical equipment must make sure that the equipment is properly disposed of if he no longer wants to keep the equipment. The old equipment can be returned to a suitable collection point that will dispose of the equipment in accordance with the national recycling and waste disposal regulations. This does not apply to any accessories or aids without electrical components supplied with the old equipment.

The reprinting or reproduction by any other means, in whole or in part, of documentation and papers accompanying products is permitted only with the express consent of the iSC GmbH.

Subject to technical changes

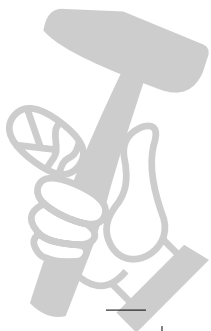

Service information

We have competent service partners in all countries named on the guarantee certificate whose contact details can also be found on the guarantee certificate. These partners will help you with all service requests such as repairs, spare and wearing part orders or the purchase of consumables.

Please note that the following parts of this product are subject to normal or natural wear and that the following parts are therefore also required for use as consumables.

Category	Example
Wear parts*	spark plug, air filter, petrol filter
Consumables*	
Missing parts	

* Not necessarily included in the scope of delivery!

In the event of defects or faults, please register the problem on the internet at www.isc-gmbh.info. Please ensure that you provide a precise description of the problem and answer the following questions in all cases:

- Did the equipment work at all or was it defective from the beginning?
- Did you notice anything (symptom or defect) prior to the failure?
- What malfunction does the equipment have in your opinion (main symptom)?
Describe this malfunction.

МАГАЗИН МАЙСТОРА®
БАШ МАЙСТОРА®
ПРОФЕСИОНАЛНИ РЕШЕНИЯ

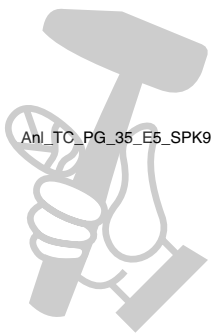

Warranty certificate

Dear Customer,

All of our products undergo strict quality checks to ensure that they reach you in perfect condition. In the unlikely event that your device develops a fault, please contact our service department at the address shown on this guarantee card. You can also contact us by telephone using the service number shown.

Please note the following terms under which guarantee claims can be made:

1. These guarantee terms apply to consumers only, i.e. natural persons intending to use this product neither for their commercial activities nor for any other self-employed activities. These warranty terms regulate additional warranty services, which the manufacturer mentioned below promises to buyers of its new products in addition to their statutory rights of guarantee. Your statutory guarantee claims are not affected by this guarantee. Our guarantee is free of charge to you.
2. The warranty services cover only defects due to material or manufacturing faults on a product which you have bought from the manufacturer mentioned below and are limited to either the rectification of said defects on the product or the replacement of the product, whichever we prefer.
Please note that our devices are not designed for use in commercial, trade or professional applications. A guarantee contract will not be created if the device has been used by commercial, trade or industrial business or has been exposed to similar stresses during the guarantee period.
3. The following are not covered by our guarantee:
 - Damage to the device caused by a failure to follow the assembly instructions or due to incorrect installation, a failure to follow the operating instructions (for example connecting it to an incorrect mains voltage or current type) or a failure to follow the maintenance and safety instructions or by exposing the device to abnormal environmental conditions or by lack of care and maintenance.
 - Damage to the device caused by abuse or incorrect use (for example overloading the device or the use of unapproved tools or accessories), ingress of foreign bodies into the device (such as sand, stones or dust, transport damage), the use of force or damage caused by external forces (for example by dropping it).
 - Damage to the device or parts of the device caused by normal or natural wear or tear or by normal use of the device.
4. The guarantee is valid for a period of 24 months starting from the purchase date of the device. Guarantee claims should be submitted before the end of the guarantee period within two weeks of the defect being noticed. No guarantee claims will be accepted after the end of the guarantee period. The original guarantee period remains applicable to the device even if repairs are carried out or parts are replaced. In such cases, the work performed or parts fitted will not result in an extension of the guarantee period, and no new guarantee will become active for the work performed or parts fitted. This also applies if an on-site service is used.
5. To make a claim under the guarantee, please register the defective device at: www.isc-gmbh.info. Please keep your bill of purchase or other proof of purchase for the new device. Devices that are returned without proof of purchase or without a rating plate shall not be covered by the guarantee, because appropriate identification will not be possible. If the defect is covered by our guarantee, then the item in question will either be repaired immediately and returned to you or we will send you a new replacement.

Of course, we are also happy offer a chargeable repair service for any defects which are not covered by the scope of this guarantee or for units which are no longer covered. To take advantage of this service, please send the device to our service address.

Also refer to the restrictions of this warranty concerning wear parts, consumables and missing parts as set out in the service information in these operating instructions.

