

# Einhell

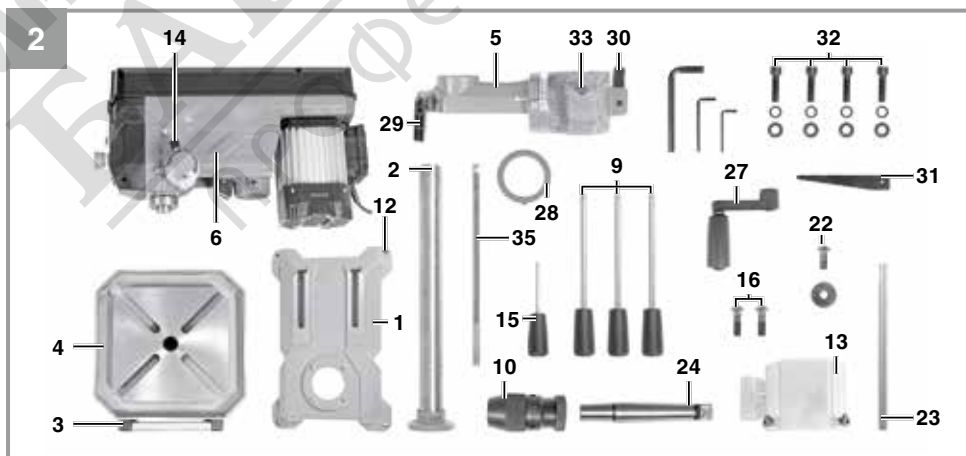
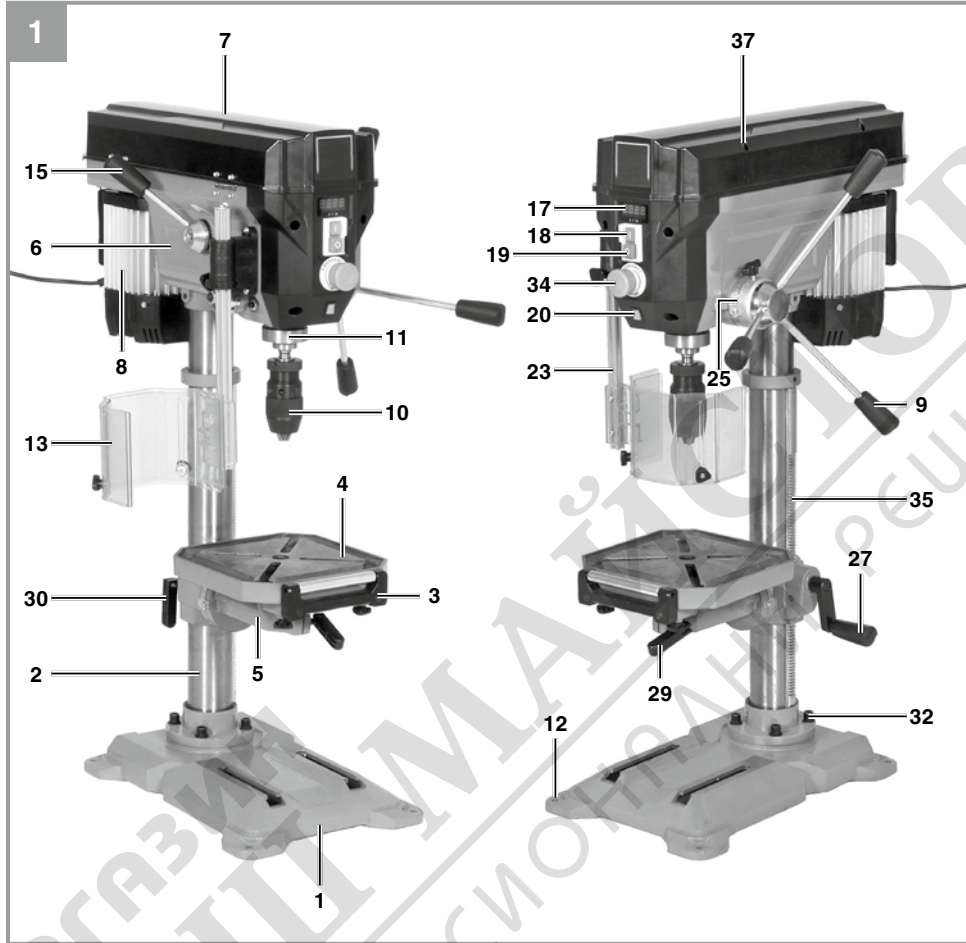
## TE-BD 750 E

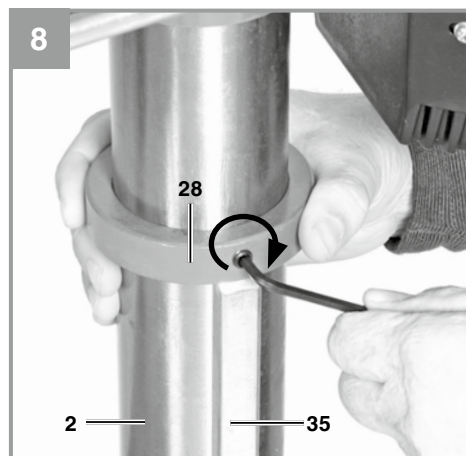
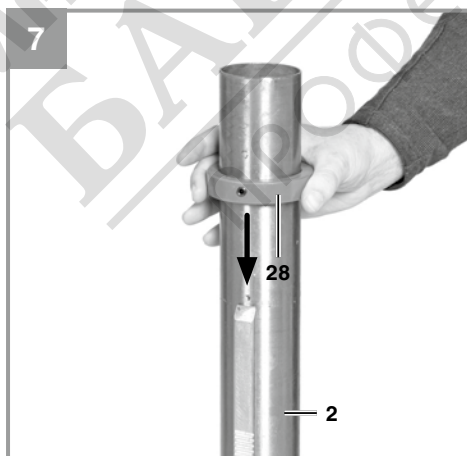
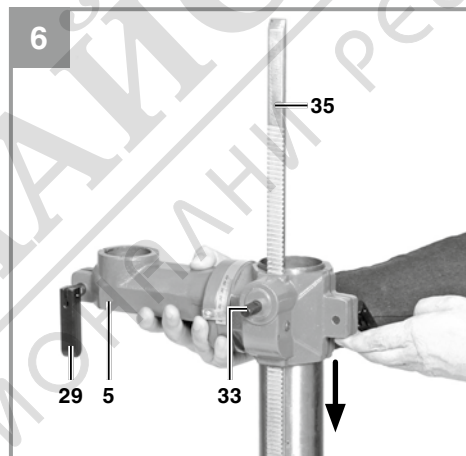
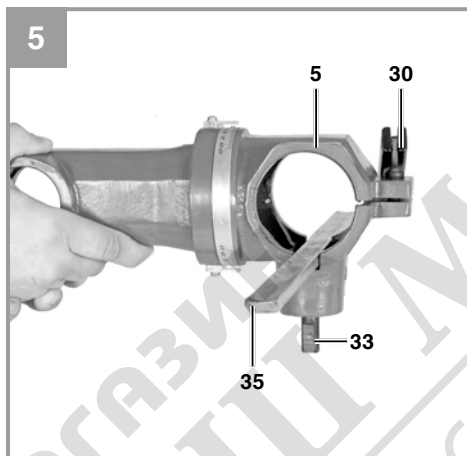
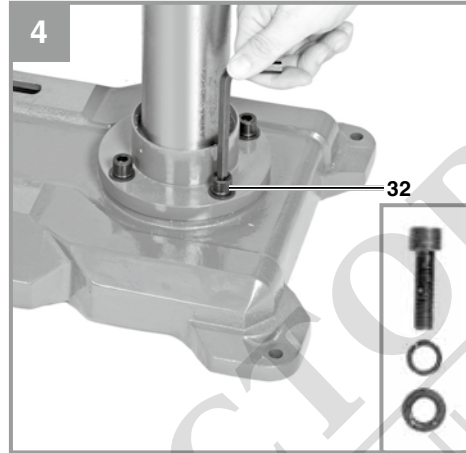
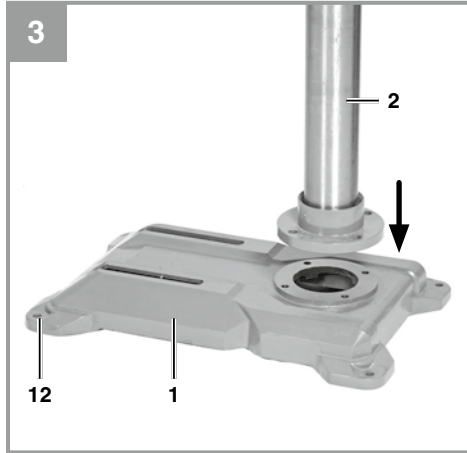
D	Originalbetriebsanleitung Säulenbohrmaschine	E	Manual de instrucciones original Taladro de columna
GB	Original operating instructions Bench Drill	FIN	Alkuperäiskäyttöohje Pylväsporakone
F	Instructions d'origine Perceuse à colonne	RUS	Оригинальное руководство по эксплуатации сверлильный станок
I	Istruzioni per l'uso originali Trapano a colonna	SLO	Originalna navodila za uporabo Stebrni vrtni stroj
S	Original-bruksanvisning Pelarbormaskin	H	Eredeti használati utasítás Oszlopos fúrógép
CZ	Originální návod k obsluze Sloupová vrtačka	GR	Πρωτότυπες Οδηγίες χρήσης Δράπανο κολωνάτο
SK	Originálny návod na obsluhu Stĺpová vrtačka		
NL	Originele handleiding Kolomboormachine		

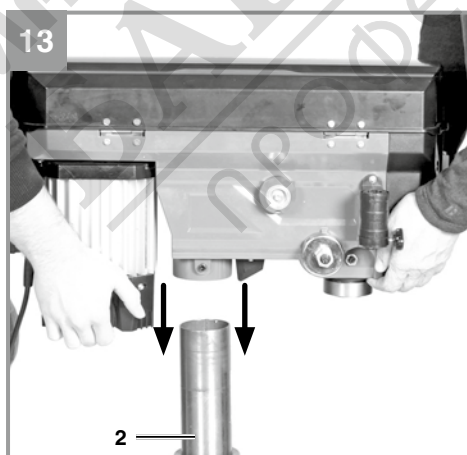
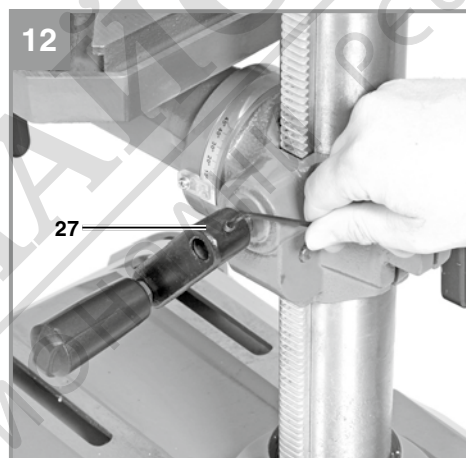
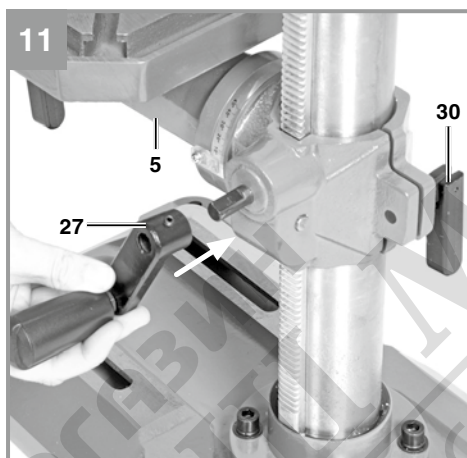
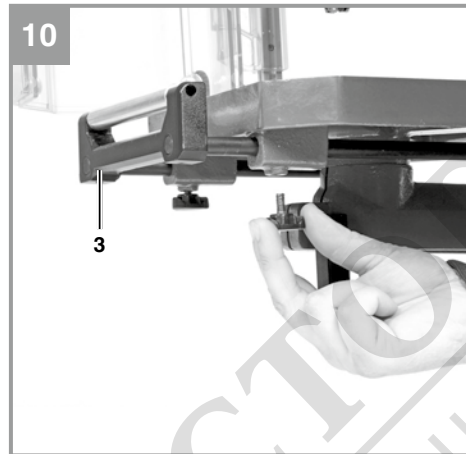
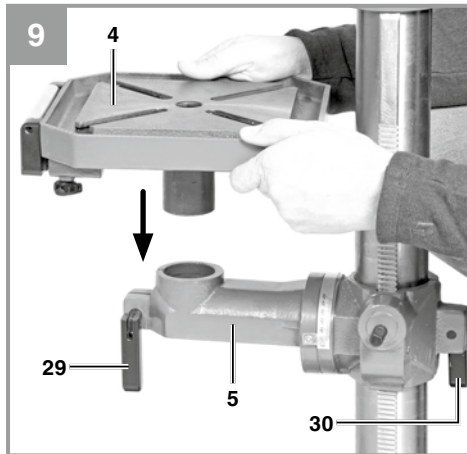


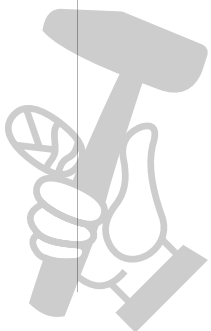
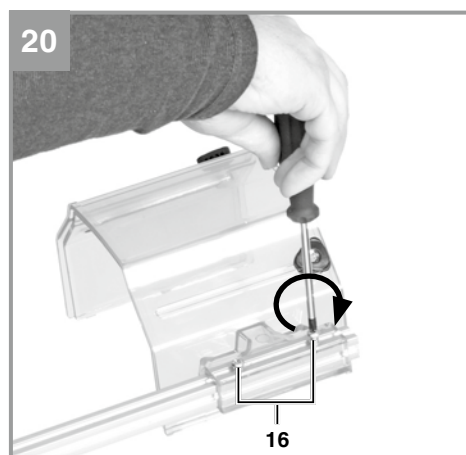
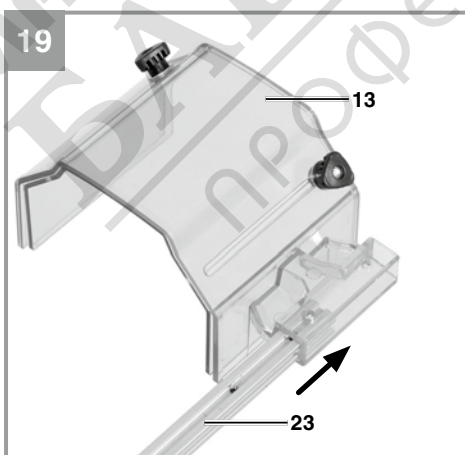
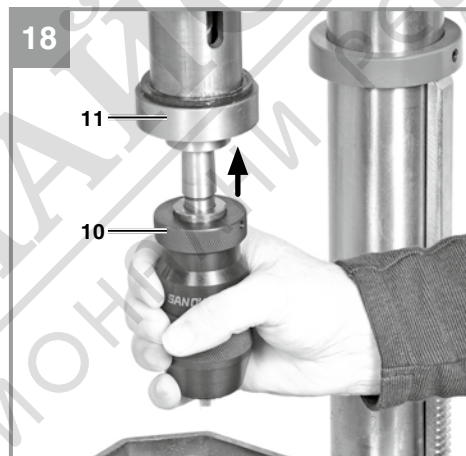
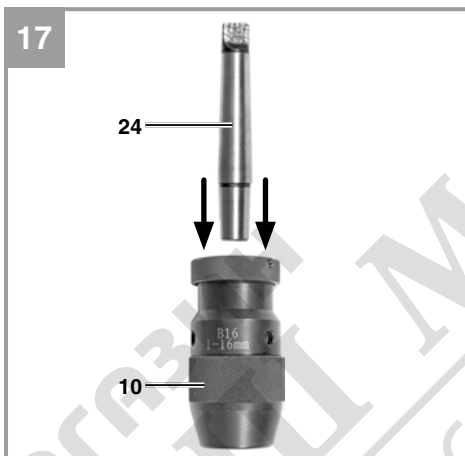
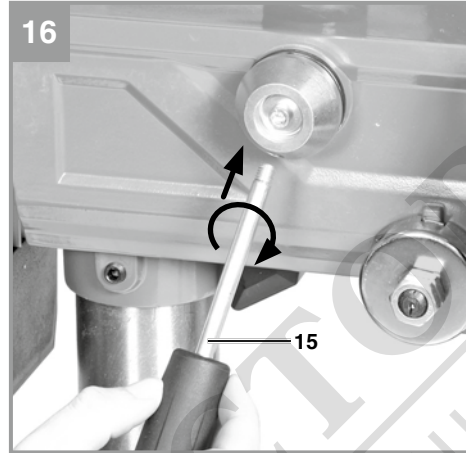
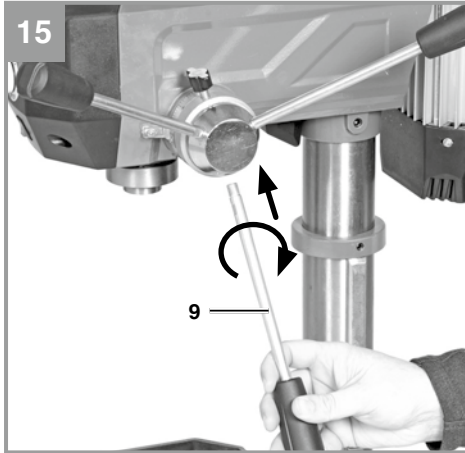
Art.-Nr.: 42.507.15

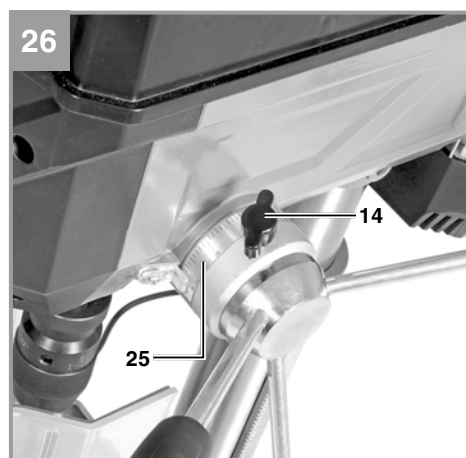
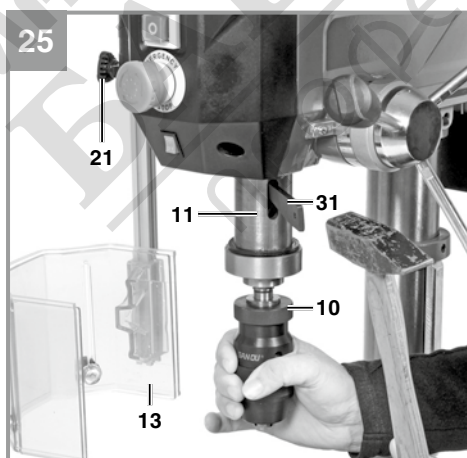
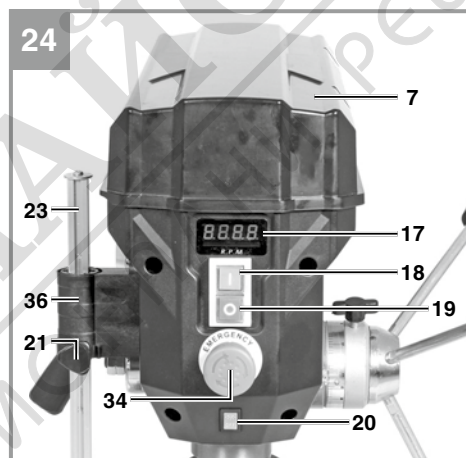
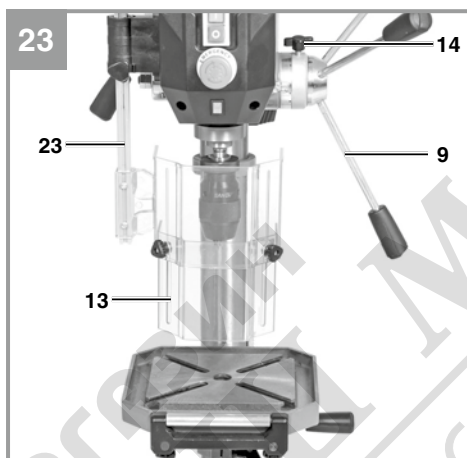
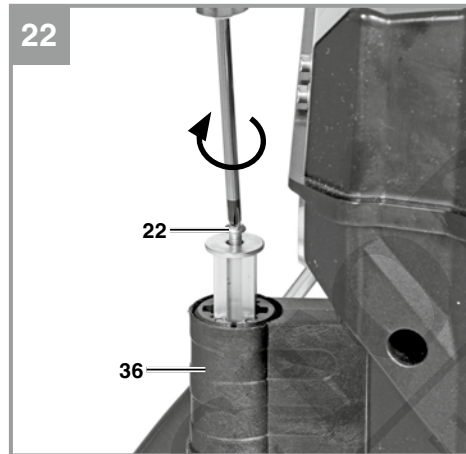
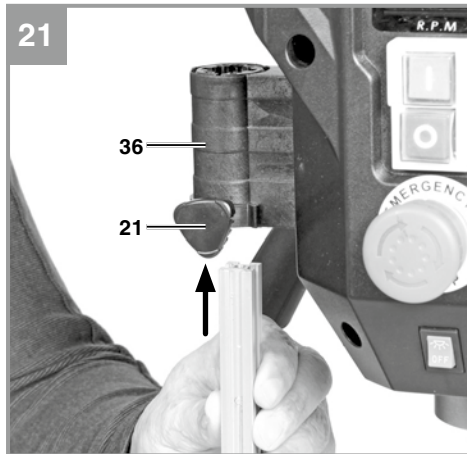
I.-Nr.: 11016

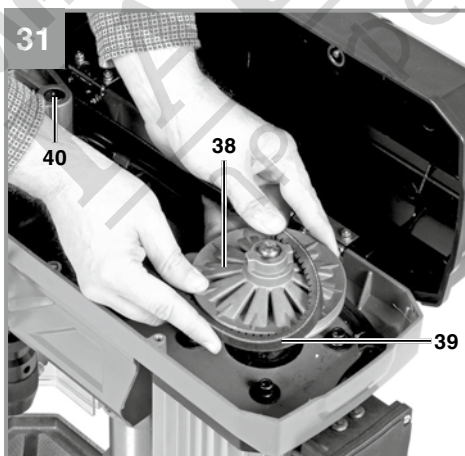
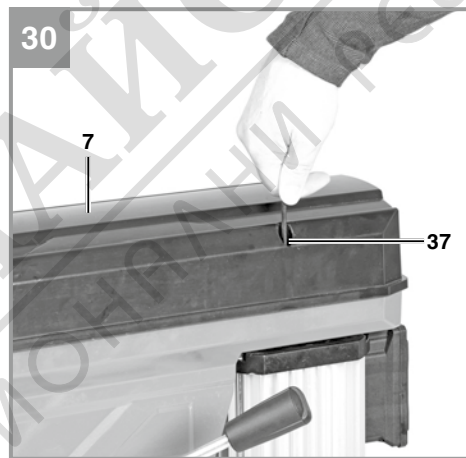
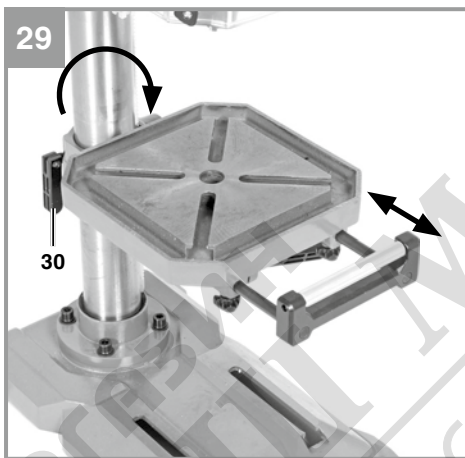
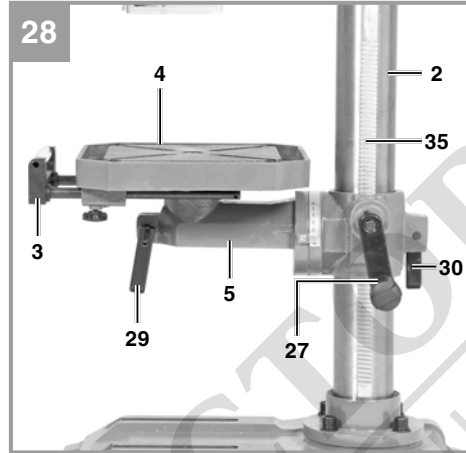
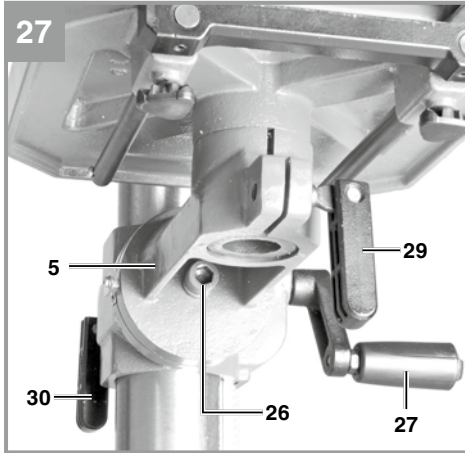






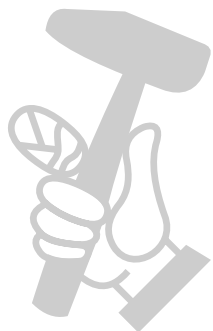






**Table of contents**

1. Safety regulations
2. Layout and items supplied
3. Proper use
4. Technical data
5. Before starting the equipment
6. Operation
7. Replacing the power cable
8. Cleaning, maintenance and ordering of spare parts
9. Disposal and recycling



МАГАЗИН  
БАШ МАЙСТОРА®  
ПРОФЕССИОНАЛНИ РЕШЕНИЯ



**Danger!** - Read the operating instructions to reduce the risk of injury



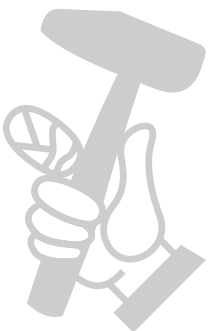
**Caution! Wear ear-muffs.** The impact of noise can cause damage to hearing.



**Caution! Wear a breathing mask.** Dust which is injurious to health can be generated when working on wood and other materials. Never use the device to work on any materials containing asbestos!



**Caution! Wear safety goggles.** Sparks generated during working or splinters, chips and dust emitted by the device can cause loss of sight.



**Danger!**

When using the equipment, a few safety precautions must be observed to avoid injuries and damage. Please read the complete operating instructions and safety regulations with due care. Keep this manual in a safe place, so that the information is available at all times. If you give the equipment to any other person, hand over these operating instructions and safety regulations as well. We cannot accept any liability for damage or accidents which arise due to a failure to follow these instructions and the safety instructions.

**1. Safety regulations**

The corresponding safety information can be found in the enclosed booklet.

**Danger!****Read all safety regulations and instructions.**

Any errors made in following the safety regulations and instructions may result in an electric shock, fire and/or serious injury.

**Keep all safety regulations and instructions in a safe place for future use.****2. Layout and items supplied****2.1 Layout (Fig. 1)**

1. Machine base
2. Pillar
3. Roll base
4. Drill table
5. Drill table clamp shaft
6. Machine head
7. V-belt cover
8. Motor
9. Rotary feed handle
10. Drill chuck
11. Spindle
12. Mounting holes
13. Folding chip guard
14. Depth stop
15. Speed control lever
16. Fastening screws for chip guard
17. Digital display
18. ON switch
19. OFF switch
20. On/ Off switch for LED lamp
21. Height adjustment screw for chip guard
22. Stop screw for chip guard
23. Fastening rail for chip guard
24. Taper mandrel

25. Scale ring
26. Socket head screw
27. Crank
28. Locking ring
29. Clamping screw for drill table
30. Clamping screw for drill table support
31. Drill drift
32. Fastening screws
33. Spindle for height adjustment
34. Emergency Stop switch
35. Gear rack
36. Holder for chip guard
37. Locking screw for V-belt cover
38. Drive pulley
39. V-belt
40. Variable pulley

**2.2 Items supplied**

Please check that the article is complete as specified in the scope of delivery. If parts are missing, please contact our service center or the sales outlet where you made your purchase at the latest within 5 working days after purchasing the product and upon presentation of a valid bill of purchase. Also, refer to the warranty table in the service information at the end of the operating instructions.

- Open the packaging and take out the equipment with care.
- Remove the packaging material and any packaging and/or transportation braces (if available).
- Check to see if all items are supplied.
- Inspect the equipment and accessories for transport damage.
- If possible, please keep the packaging until the end of the guarantee period.

**Danger!**

**The equipment and packaging material are not toys. Do not let children play with plastic bags, foils or small parts. There is a danger of swallowing or suffocating!**

- Original operating instructions
- Safety instructions
- Pillar drill
- Drill chuck
- Folding chip guard

### 3. Proper use

This pillar drill is designed for drilling metal, plastic, wood and similar materials. It is intended for use in the private sector only.

Food and harmful materials may not be processed with the machine. The drill chuck is only designed for use with drill bits and tools with a shaft diameter of 1,5 to 16 mm, and for cylindrical tool shanks. Tools with a tapered shank can also be used. The machine is intended for use by adults only.

The equipment is to be used only for its prescribed purpose. Any other use is deemed to be a case of misuse. The user / operator and not the manufacturer will be liable for any damage or injuries of any kind caused as a result of this.

Please note that our equipment has not been designed for use in commercial, trade or industrial applications. Our warranty will be voided if the machine is used in commercial, trade or industrial businesses or for equivalent purposes.

### 4. Technical data

Nominal input voltage	220-240V ~ 50 Hz
Nominal output	750 W S2 15 min
Motor speed	1400 min <sup>-1</sup>
Output speed (infinitely adjustable)	450-2500 min <sup>-1</sup>
Drill chuck mount	B 16
Spindle taper	MK 2
Scroll chuck	Ø 1-16 mm
Reach	160 mm
Dimensions of drill table	243 x 243 mm
Angle adjustment of	table 45° / 0° / 45°
Drill depth	80 mm
Pillar diameter	65 mm
Height	955 mm
Base area	456 x 304 mm
Weight	43 kg

#### Danger!

#### Sound and vibration

Sound and vibration values were measured in accordance with EN 61029.

L <sub>pA</sub> sound pressure level	81.2 dB(A)
K <sub>pA</sub> uncertainty	2 dB
L <sub>wA</sub> sound power level	90.3 dB(A)
K <sub>wA</sub> uncertainty	2 dB

#### Wear ear-muffs.

The impact of noise can cause damage to hearing.

Total vibration values (vector sum of three directions) determined in accordance with EN 61029.

Vibration emission value  $a_n \leq 2.5 \text{ m/s}^2$   
K uncertainty = 1.5 m/s<sup>2</sup>

#### Warning!

The specified vibration value was established in accordance with a standardized testing method. It may change according to how the electric equipment is used and may exceed the specified value in exceptional circumstances.

The specified vibration value can be used to compare the equipment with other electric power tools.

The specified vibration value can be used for initial assessment of a harmful effect.

#### Keep the noise emissions and vibrations to a minimum.

- Only use appliances which are in perfect working order.
- Service and clean the appliance regularly.
- Adapt your working style to suit the appliance.
- Do not overload the appliance.
- Have the appliance serviced whenever necessary.
- Switch the appliance off when it is not in use.
- Wear protective gloves.

#### Caution!

#### Residual risks

**Even if you use this electric power tool in accordance with instructions, certain residual risks cannot be ruled out. The following hazards may arise in connection with the equipment's construction and layout:**

1. Lung damage if no suitable protective dust mask is used.
2. Damage to hearing if no suitable ear protection is used.
3. Health damage caused by hand-arm vibrations if the equipment is used over a

prolonged period or is not properly guided and maintained.

## 5. Before starting the equipment

### 5.1 Assembling the machine

- Place the base plate (1) in the desired position.
- Fasten the pillar (2) with flange using the supplied screws (32). (Fig. 3-4)
- Insert the gear rack (35) in the center of the guide rail provided for it on the drill table support (5) (Fig. 5). Hold the gear rack (35) in position while sliding the drill table support (5) onto the pillar (2) from above (Fig. 6).
- Now position the locking ring (28) on the pillar (2) so that it rests lightly on the gear rack (35). Then fasten it with the socket head screw (Figs. 7-8)
- Now place the drill table (4) on the drill table support (5) and fasten it with the clamping screw (29). (Fig. 9)
- Following this, fit the crank (27) and fasten tightly with the screw (Figs. 11-12).
- Finally, fit the complete bit head to the pillar (6) to the pillar (2). Align the head so that it is vertical to the base plate (1) and fasten it in on both sides with the fitted socket head screws. (Fig. 14)
- Screw the 3 supplied handles (9) in the handle mounts. (Fig. 15)
- Screw in the speed control lever (15) as shown in Figure 16.
- Secure the roller support (3) with thumb screws (21). (Fig. 10)
- Before you mount the drill chuck with the MK shank, check that both parts are clean. Insert the taper mandrel (24) in the taper of the drill chuck (10) with a powerful jolt (Fig. 17). Then insert the drill chuck in the drill spindle. To do this, place the drill chuck (10) with taper mandrel (24) in the spindle (11) and guide it to the stop point, then turn the chuck until it slips a little further into the spindle (11). Insert the drill chuck (10) with taper mandrel (24) into the spindle (11) with a jolt and check that the chuck is secure. (Fig. 17-18)

**Important:** All bare parts are greased in order to protect them from corrosion. Before mounting the drill chuck (10) onto the spindle (11), both parts must be completely degreased using an environmentally friendly solvent. This ensures optimal

transmission of power.

### 5.2. Installing the machine

Before you use the drill for the first time it must be mounted in a stationary position on a firm surface. Use both mounting holes (12) in the base plate to do this. Ensure that the machine is freely accessible for operation, adjustment and maintenance.

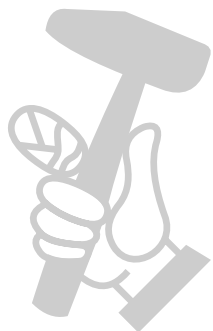
**Important:** The fixing screws may only be tightened to a point where they do not distort or deform the base plate. Excessive tension can lead to fracture.

### 5.3 Folding chip guard (Figs. 19-22)

- To assemble and fit the chip guard (13), slide the fastening rail (23) into the provided opening on the chip guard (13) (Fig. 19).
- Secure the rail to the guard using the screws (16) (Fig. 20).
- Now push the fastening rail (23) into the holder (36) on the machine head (6) (Fig. 21).  
**Note:** The chip guard (13) is equipped with a microswitch. This prevents the machine starting up if the chip guard is open. To ensure that it functions correctly, the chip guard (13) must be fitted in the "closed" position (Fig. 23).
- Now fit the stop washer with the screw No. 22 (Fig. 22).
- The height of the chip guard (13) is infinitely adjustable and can be locked using the thumb screw (21). The chip guard (13) can be flipped to the side to enable bits to be changed.

### 5.4 Prior to starting

Ensure that the voltage of the mains supply complies with the specifications on the rating plate. Connect the machine only to a socket with the properly installed earthing contact. The table drill is equipped with a no-volt trip that is designed to protect the operator from an undesired restart following a drop in voltage. Should this occur, the machine must be manually restarted.



## 6. Operation

### 6.1 General (Fig. 24)

To switch on the machine, push in the green On button "I" (18); the machine starts up. To switch off, press the red Off button "O" (19); the device shuts down.

Ensure that you do not overload the device.

If the sound of the motor drops in pitch during operation, it is being overloaded.

Do not overload the device to the point where the motor comes to a standstill. Always stand in front of the machine during operation.

**Note:** Pressing the Emergency Stop switch (34) enables the machine to be brought to an immediate standstill in an emergency

### 6.2 Inserting the tool (Fig. 1)

Make sure that the power plug is removed from the socket-outlet before changing tools. Only cylindrical tools with the stipulated maximum shaft diameter may be clamped in the scroll chuck (10). Only use a tool that is sharp and free of defects. Do not use tools whose shaft is damaged or which are deformed or flawed in any other way. Use only accessories and attachments that are specified in the operating instructions or have been approved by the manufacturer. If the pillar drill should become jammed, switch off the machine and return the drill to its starting position.

### 6.3 Handling the keyless chuck

Your pillar drill is equipped with a keyless chuck. This enables tools to be changed without the need for an additional chuck key. To do so, insert the tool in the quick-change drill chuck and tighten by hand.

### 6.4 Using tools with tapered shanks (Fig. 25)

The pillar drill comes with a spindle taper. To use tools with tapered shanks (MK2), proceed as follows:

- Move the drill chuck to the lower position.
- Lock the spindle in the lowered position using the bottom scale ring (25) to maximize access to the drill chuck (Fig. 25).
- Eject the tapered shank using the supplied drill drift (31), taking care as you do so to ensure that the tool does not land on the floor.
- Insert the new tool with tapered shank in the spindle taper with a jolt and then check that the tool is correctly seated.

### 6.5 Setting the speed (Fig. 1)

The operating speed of the machine is infinitely adjustable.

#### Important!

- **Speed adjustments are allowed only when the motor is running.**
- **Slowly and steadily move the speed control lever (15) while the machine is in idle mode.**
- **Ensure that the machine can run without interruption (i.e. remove workpieces, drill bits, etc.).**

Use the speed control lever (15) to infinitely adjust the speed. The set speed is shown on the digital display (17) in revolutions per minute.

**Important!** Never let the pillar drill run when the V-belt cover is open. Always pull power plug before opening the cover. Never touch the V-belt when it is rotating.

### 6.6 Drill depth stop point (Fig. 25-26)

The drilling spindle has a swiveling scale ring for setting the drill depth. Only adjust the settings when the equipment is at a standstill.

- Press the drilling spindle (11) downwards until the tip of the drill bit touches the workpiece.
- Slacken the clamping screw (14) and turn the scale ring (25) forwards until it stops.
- Turn the scale ring (25) back to the desired drill depth, then lock this setting into place using the clamping screw (14).

### 6.7 Setting the angle of the drill table (Fig. 27,28)

- Slacken the carriage bolt (26) under the drill table (4).
- Set the drill table (4) to the desired angle.
- Tighten down the carriage bolt (26) in order to lock the drill table (4) into this position.

### 6.8 Setting the height of the drill table (Fig. 1,28,29)

- Slacken the tightening screw (30).
- Set the drill table to the desired position with the help of the hand crank (27).
- Screw the tightening screw (30) back down again.

### 6.9 Drill table and roll base (Fig. 29)

- Slacken the clamping screw (29) to turn the drill table (4).
- Slacken the thumb screws to extend the roll base (3).

### 6.10 Clamping the workpiece (Fig. 29)

As a general rule, use a machine vice or another suitable clamping device to secure a workpiece in position. Never hold the workpiece in place with your hand! When drilling, the workpiece should be able to travel on the drill table (4) for self-centering purposes. Ensure that the workpiece cannot rotate. This is best achieved by placing the workpiece /machine vice on a sturdy block.

**Caution!** Sheet metal parts must be clamped in to prevent them from being torn up. Properly set the height and angle of the drill table for each workpiece. There must be enough distance between the upper edge of the workpiece and the tip of the drill bit.

### 6.11 LED lamp (Figs. 1, 2)

The table drill is equipped with an LED lamp for illuminating the work area. This can be switched ON and OFF by the switch (20).

### 6.12 Working speeds

Ensure that you drill at the proper speed. Drill speed is dependent on the diameter of the drill bit and the material in question.

The table below acts as a guide for selecting the proper speed for various materials.

**Note: The drill speeds specified are merely suggested values.**

Drill bit Ø	Cast iron	Steel	Iron	Aluminium	Bronze
3	2550	1600	2230	9500	8000
4	1900	1200	1680	7200	6000
5	1530	955	1340	5700	4800
6	1270	800	1100	4800	4000
7	1090	680	960	4100	3400
8	960	600	840	3600	3000
9	850	530	740	3200	2650
10	765	480	670	2860	2400
11	700	435	610	2600	2170
12	640	400	560	2400	2000
13	590	370	515	2200	1840
14	545	340	480	2000	1700
16	480	300	420	1800	1500
18	425	265	370	1600	1300
20	380	240	335	1400	1200
22	350	220	305	1300	1100
25	305	190	270	1150	950

### 6.13 Countersinking and center-drilling

With this table drill, you can also countersink and center-drill. Please observe that countersinking should be performed at the lowest speed, while a high speed is required for center-drilling.

### 6.14 Drilling wood

Please note that sawdust must be properly evacuated when working with wood, as it can pose a health hazard. Ensure that you wear a suitable dust mask when performing work that generates dust.

## 7. Replacing the power cable

### Danger!

If the power cable for this equipment is damaged, it must be replaced by the manufacturer or its after-sales service or similarly trained personnel to avoid danger.

## 8. Cleaning, maintenance and ordering of spare parts

### Danger!

Always pull out the mains power plug before starting any cleaning work.

### 8.1 Cleaning

- The table drill is to a large extent maintenance-free. Keep the device clean. Pull out the mains plug before doing any cleaning and maintenance work on the machine. Do not

use any harsh, abrasive cleaning solvents. Ensure that no liquid seeps into the device. Regrease all bare parts when the work is finished. The drill pillar, blank parts of the column, and the drill table especially should be regreased at regular intervals. Use a standard, acid-free lubricating grease to do this.

**Caution:** Do not use your household refuse bin as a receptacle for oil and grease-soaked cleaning rags or grease and oil sludge. Dispose of these toxic materials in an environmentally-friendly fashion. Regularly check and clean the ventilation holes. Store the device in a dry room. Should the device become damaged, do not try to repair it yourself; leave this work to the hands of a qualified electrical technician.

- We recommend that you clean the device immediately each time you have finished using it.
- Clean the equipment regularly with a moist cloth and some soft soap. Do not use cleaning agents or solvents; these could attack the plastic parts of the equipment. Ensure that no water can seep into the device. The ingress of water into an electric tool increases the risk of an electric shock.

## 8.2 Maintenance

There are no parts inside the equipment which require additional maintenance.

### 8.2.1 Changing the V-belt (Figs. 31-32)

The V-belt of the pillar drill is a wear part and should be replaced when worn. Proceed as follows:

- Run the machine in idle mode while slowly setting the speed adjuster lever (15) to the minimum speed.
- Switch the machine off, then pull the power plug.
- Set the speed adjuster lever (15) to the maximum speed setting to slacken the V-belt.
- Undo the screw (37) to open the V-belt cover (7).
- Pry the V-belt (39) off of the drive pulley (38) by pulling up the belt on one side and slowly turning the pulley (38). The drive pulley (38) comprises two disks that are pressed together via a spring. If the V-belt (39) does not exhibit enough play to remove it, gently press the bottom half of the drive pulley (38) down to slacken the V-belt (39).
- Fit one end of the new V-belt (39) to the variable pulley (40). Fit the other end to the drive

pulley (38) by first sliding it into the groove on one side of the pulley (38), then prying the V-belt (39) across the pulley into the groove on the other side.

- Close the V-belt cover and screw down using the screw (37).

## 8.3 Ordering spare parts and accessories

Please provide the following information when ordering spare parts:

- Type of unit
- Article number of the unit
- ID number of the unit
- Spare part number of the required spare part

For our latest prices and information please go to [www.isc-gmbh.info](http://www.isc-gmbh.info)



**Tip! For good results we recommend high-quality accessories from **kwb** !**  
[www.kwb.eu](http://www.kwb.eu)  
[welcome@kwb.eu](mailto:welcome@kwb.eu)

## 9. Disposal and recycling

The equipment is supplied in packaging to prevent it from being damaged in transit. The raw materials in this packaging can be reused or recycled. The equipment and its accessories are made of various types of material, such as metal and plastic. Never place defective equipment in your household refuse. The equipment should be taken to a suitable collection center for proper disposal. If you do not know the whereabouts of such a collection point, you should ask in your local council offices.



For EU countries only

Never place any electric power tools in your household refuse.

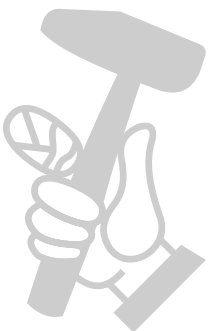
To comply with European Directive 2012/19/EC concerning old electric and electronic equipment and its implementation in national laws, old electric power tools have to be separated from other waste and disposed of in an environment-friendly fashion, e.g. by taking to a recycling depot.

Recycling alternative to the return request:

As an alternative to returning the equipment to the manufacturer, the owner of the electrical equipment must make sure that the equipment is properly disposed of if he no longer wants to keep the equipment. The old equipment can be returned to a suitable collection point that will dispose of the equipment in accordance with the national recycling and waste disposal regulations. This does not apply to any accessories or aids without electrical components supplied with the old equipment.

The reprinting or reproduction by any other means, in whole or in part, of documentation and papers accompanying products is permitted only with the express consent of the iSC GmbH.

Subject to technical changes



## Service information

We have competent service partners in all countries named on the guarantee certificate whose contact details can also be found on the guarantee certificate. These partners will help you with all service requests such as repairs, spare and wearing part orders or the purchase of consumables.

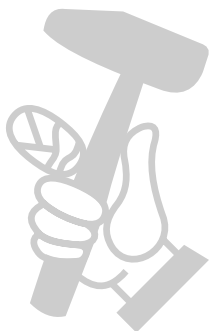
Please note that the following parts of this product are subject to normal or natural wear and that the following parts are therefore also required for use as consumables.

Category	Example
Wear parts*	V-belt
Consumables*	
Missing parts	

\* Not necessarily included in the scope of delivery!

In the effect of defects or faults, please register the problem on the internet at [www.isc-gmbh.info](http://www.isc-gmbh.info). Please ensure that you provide a precise description of the problem and answer the following questions in all cases:

- Did the equipment work at all or was it defective from the beginning?
- Did you notice anything (symptom or defect) prior to the failure?
- What malfunction does the equipment have in your opinion (main symptom)? Describe this malfunction.



## Warranty certificate

Dear Customer,

All of our products undergo strict quality checks to ensure that they reach you in perfect condition. In the unlikely event that your device develops a fault, please contact our service department at the address shown on this guarantee card. You can also contact us by telephone using the service number shown. Please note the following terms under which guarantee claims can be made:

1. These guarantee terms apply to consumers only, i.e. natural persons intending to use this product neither for their commercial activities nor for any other self-employed activities. These warranty terms regulate additional warranty services, which the manufacturer mentioned below promises to buyers of its new products in addition to their statutory rights of guarantee. Your statutory guarantee claims are not affected by this guarantee. Our guarantee is free of charge to you.
2. The warranty services cover only defects due to material or manufacturing faults on a product which you have bought from the manufacturer mentioned below and are limited to either the rectification of said defects on the product or the replacement of the product, whichever we prefer. Please note that our devices are not designed for use in commercial, trade or professional applications. A guarantee contract will not be created if the device has been used by commercial, trade or industrial business or has been exposed to similar stresses during the guarantee period.
3. The following are not covered by our guarantee:
  - Damage to the device caused by a failure to follow the assembly instructions or due to incorrect installation, a failure to follow the operating instructions (for example connecting it to an incorrect mains voltage or current type) or a failure to follow the maintenance and safety instructions or by exposing the device to abnormal environmental conditions or by lack of care and maintenance.
  - Damage to the device caused by abuse or incorrect use (for example overloading the device or the use of unapproved tools or accessories), ingress of foreign bodies into the device (such as sand, stones or dust, transport damage), the use of force or damage caused by external forces (for example by dropping it).
  - Damage to the device or parts of the device caused by normal or natural wear or tear or by normal use of the device.
4. The guarantee is valid for a period of 24 months starting from the purchase date of the device. Guarantee claims should be submitted before the end of the guarantee period within two weeks of the defect being noticed. No guarantee claims will be accepted after the end of the guarantee period. The original guarantee period remains applicable to the device even if repairs are carried out or parts are replaced. In such cases, the work performed or parts fitted will not result in an extension of the guarantee period, and no new guarantee will become active for the work performed or parts fitted. This also applies if an on-site service is used.
5. To make a claim under the guarantee, please register the defective device at: [www.isc-gmbh.info](http://www.isc-gmbh.info). Please keep your bill of purchase or other proof of purchase for the new device. Devices that are returned without proof of purchase or without a rating plate shall not be covered by the guarantee, because appropriate identification will not be possible. If the defect is covered by our guarantee, then the item in question will either be repaired immediately and returned to you or we will send you a new replacement.

Of course, we are also happy offer a chargeable repair service for any defects which are not covered by the scope of this guarantee or for units which are no longer covered. To take advantage of this service, please send the device to our service address.

Also refer to the restrictions of this warranty concerning wear parts, consumables and missing parts as set out in the service information in these operating instructions.

