

- DE** Originalbetriebsanleitung
Bandsäge
- EN** Original operating instructions
Band Saw
- FR** Mode d'emploi d'origine
Scie à ruban
- IT** Istruzioni per l'uso originali
Sega a nastro
- CS** Originální návod k obsluze
Pásová pila
- SK** Originálny návod na obsluhu
Pásová pila
- NL** Originele handleiding
Lintzaagmachine
- ES** Manual de instrucciones original
Sierra de cinta sin fin
- SL** Originalna navodila za uporabo
Tračna žaga
- HU** Eredeti használati utasítás
Szalagfűrész

**Art.-Nr.: 43.080.55****I.-Nr.: 11028**

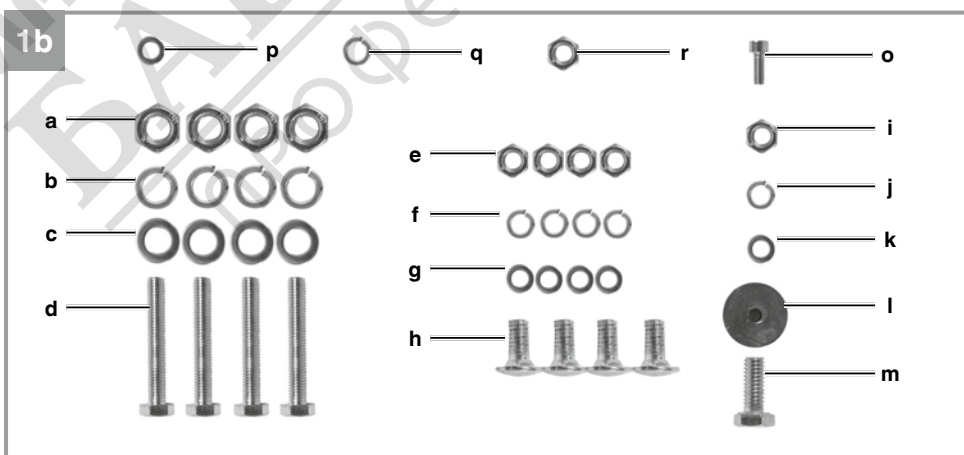

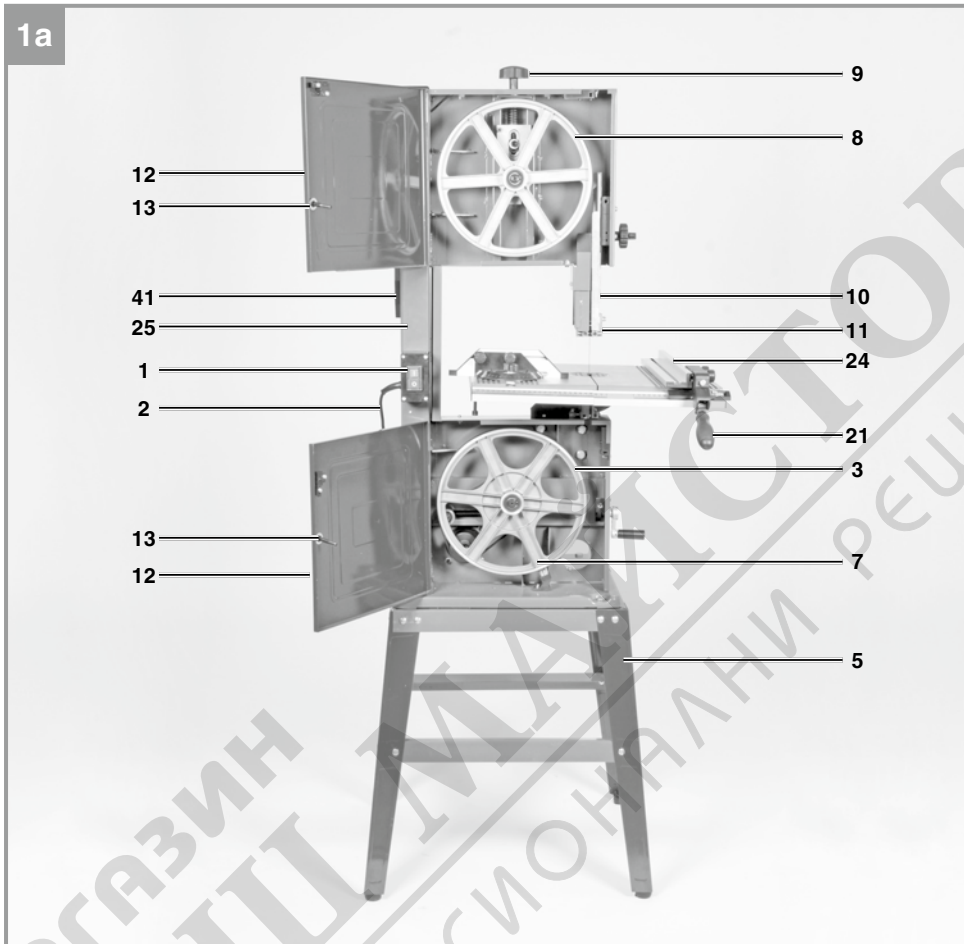

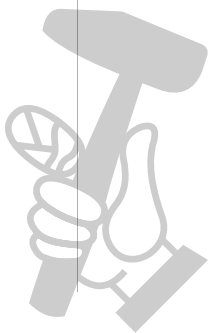
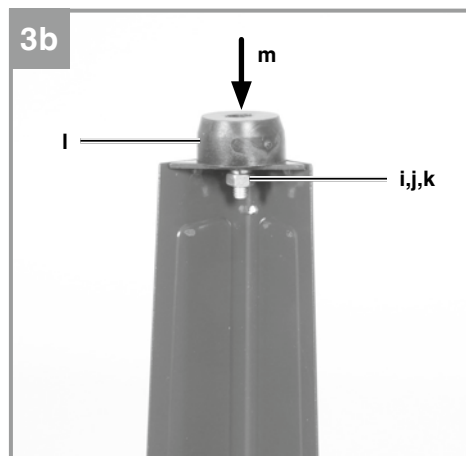
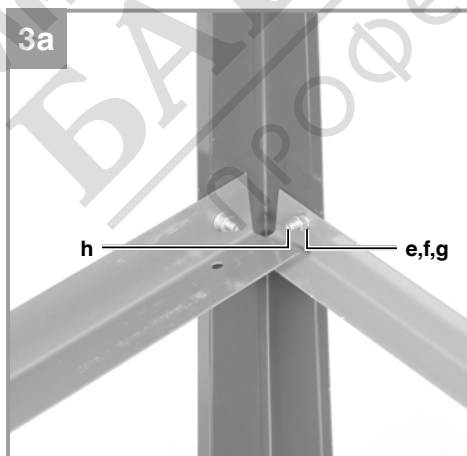
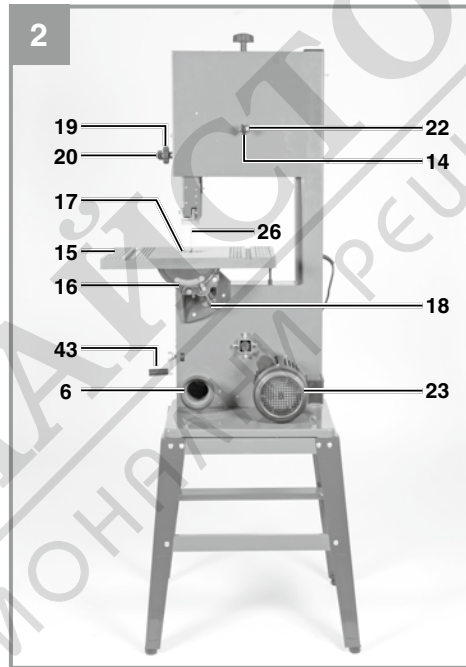
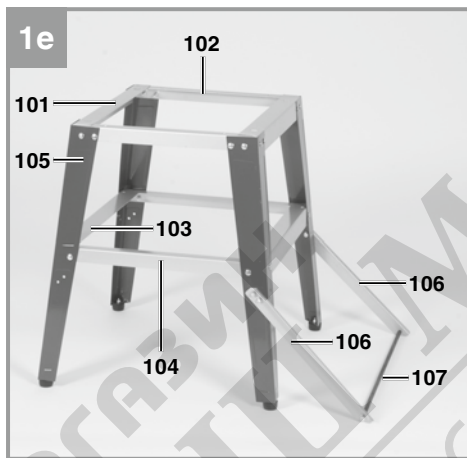
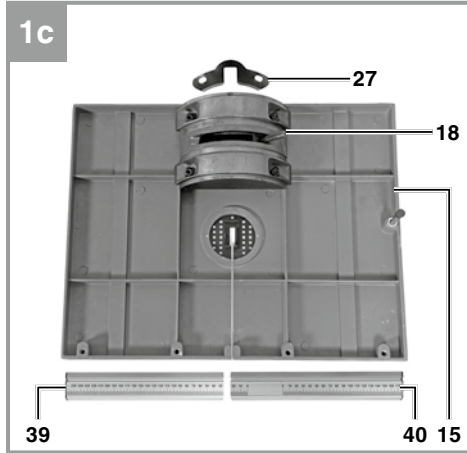
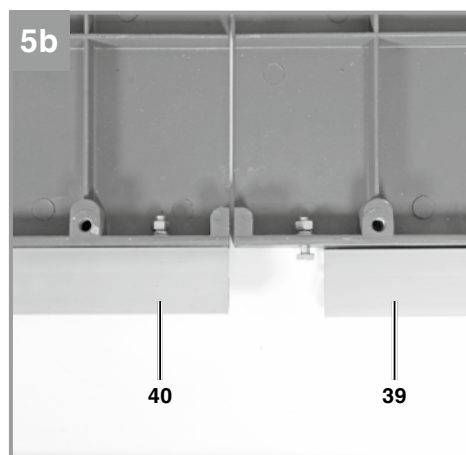
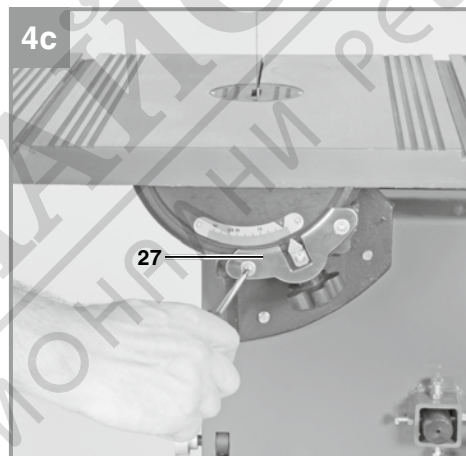
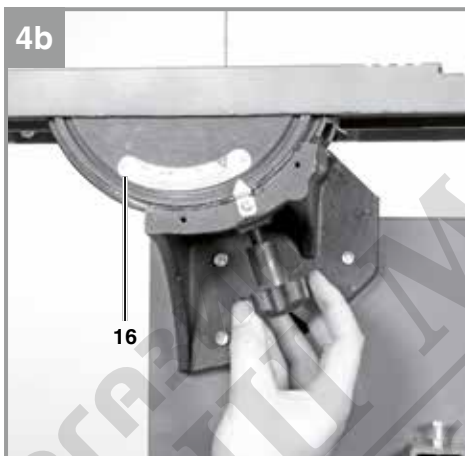
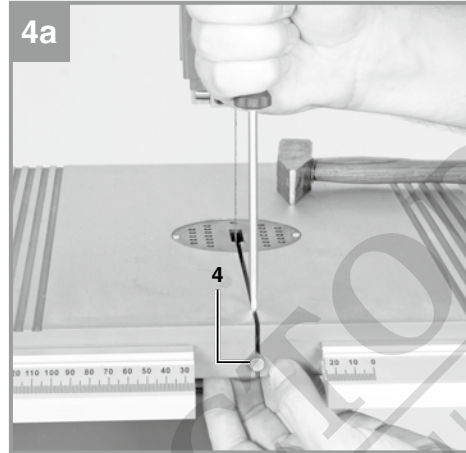

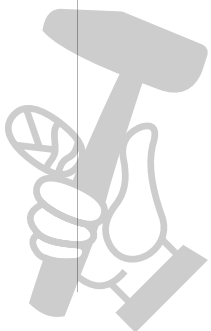
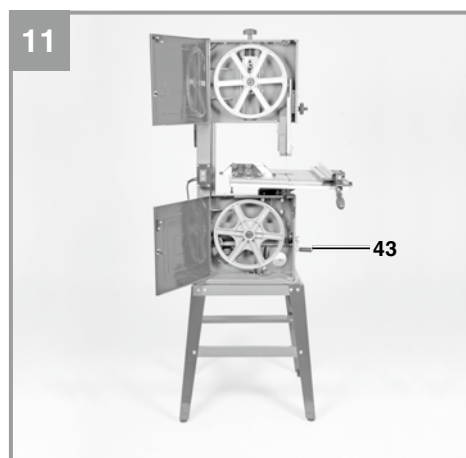
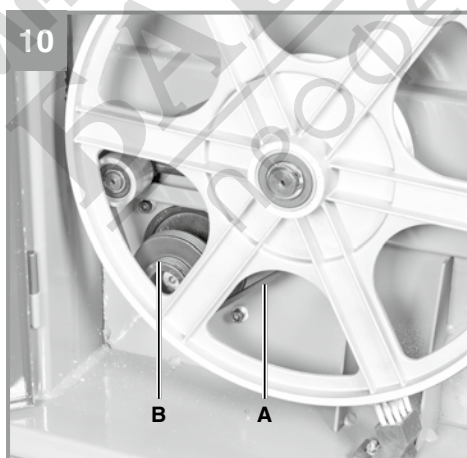
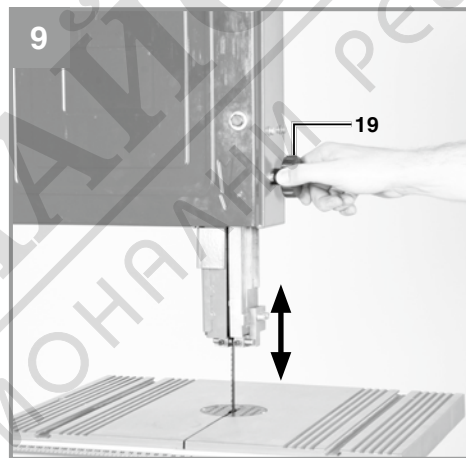
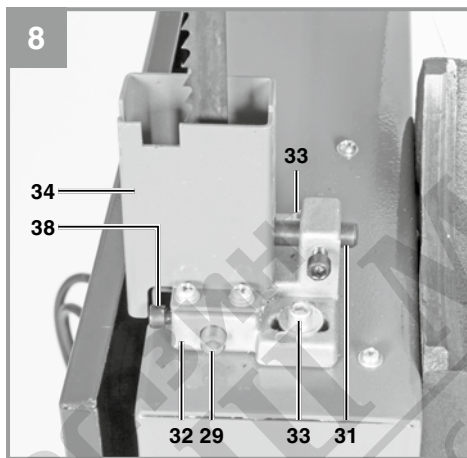
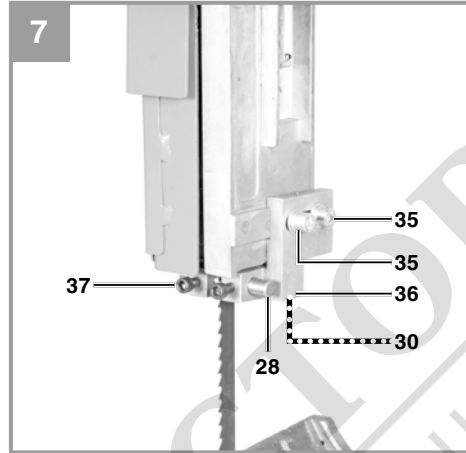
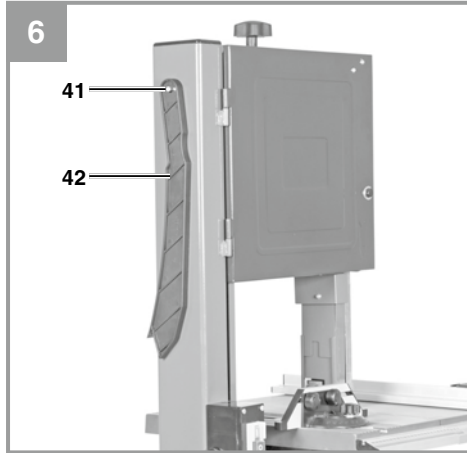

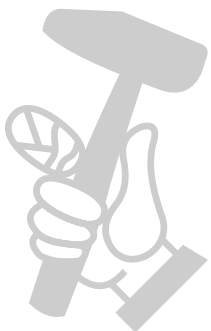
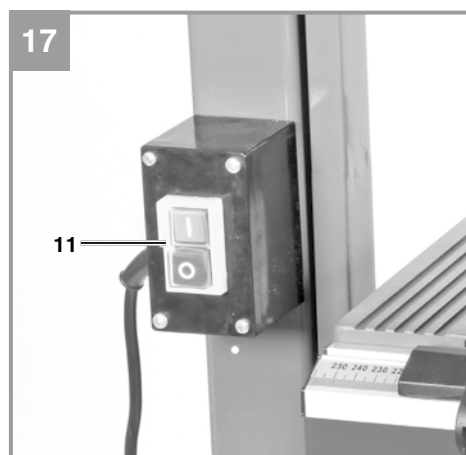
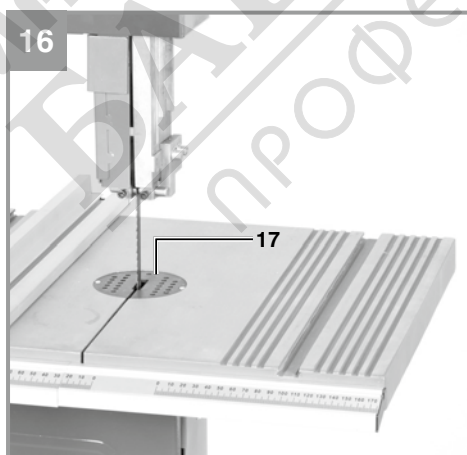
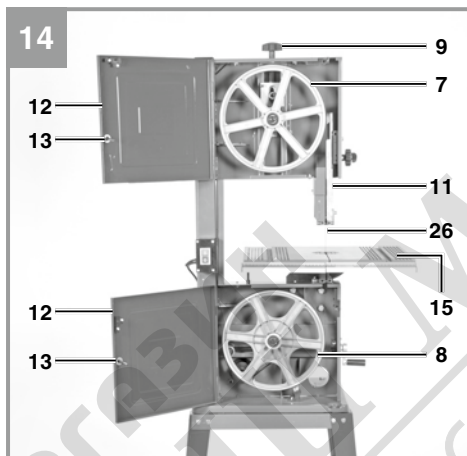
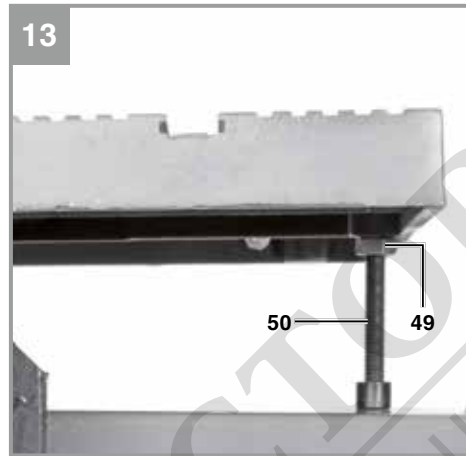
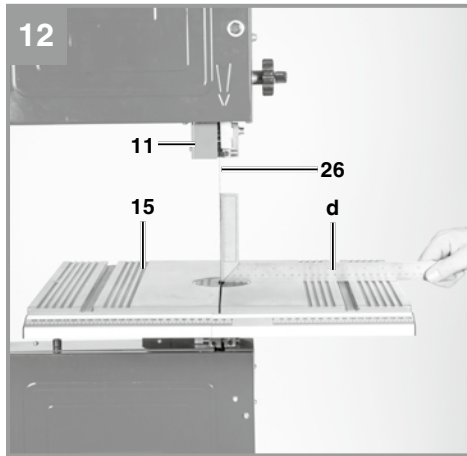

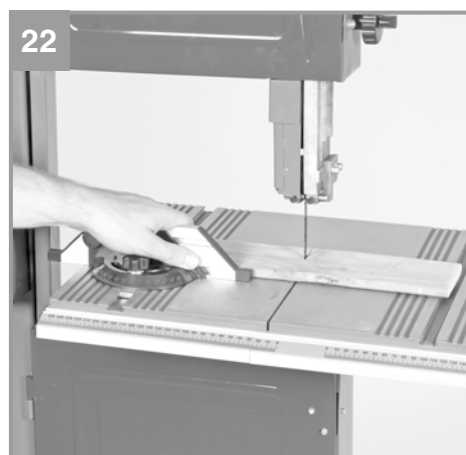
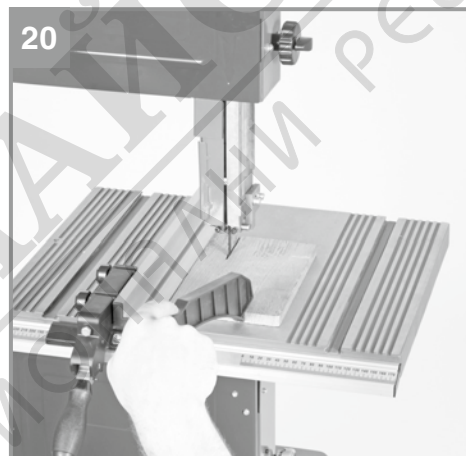
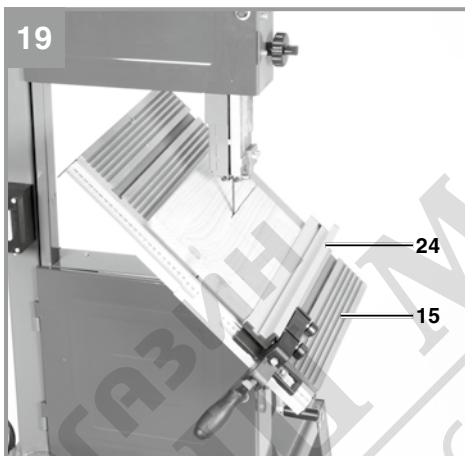
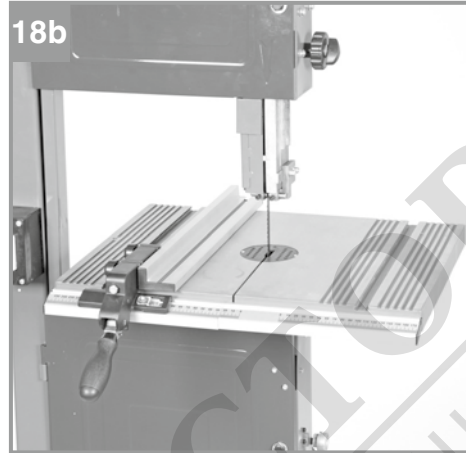
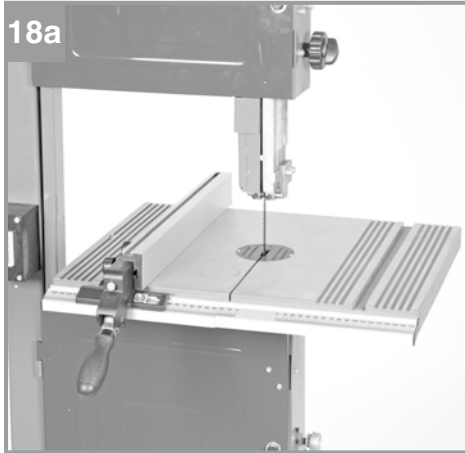



Danger! Read the operating instructions to reduce the risk of injury



Caution! Wear ear-muffs. The impact of noise can cause damage to hearing.



Caution! Wear a **breathing mask**. Dust which is injurious to health can be generated when working on wood and other materials. Never use the device to work on any materials containing asbestos!



Caution! Wear **safety goggles**. Sparks generated during working or splinters, chips and dust emitted by the device can cause loss of sight.



Pull the power plug before beginning any repair or maintenance work!



Saw blade cutting direction



Closing positions on the housing cover

Danger!

When using the equipment, a few safety precautions must be observed to avoid injuries and damage. Please read the complete operating instructions and safety regulations with due care. Keep this manual in a safe place, so that the information is available at all times. If you give the equipment to any other person, hand over these operating instructions and safety regulations as well. We cannot accept any liability for damage or accidents which arise due to a failure to follow these instructions and the safety instructions.

1. Safety regulations

The corresponding safety information can be found in the enclosed booklet.

Danger!**Read all safety regulations and instructions.**

Any errors made in following the safety regulations and instructions may result in an electric shock, fire and/or serious injury.

Keep all safety regulations and instructions in a safe place for future use.**2. Layout and items supplied****2.1 Layout (Fig. 1/2)**

1. ON/OFF switch
2. Power cord
3. Rubber tires
4. Web panel
5. Machine foot
6. Extractor socket
7. Lower blade pulley
8. Upper blade pulley
9. Tightening screw
10. Blade guard
11. Upper blade guide
12. Side cover
13. Hood closure
14. Retaining screw for upper blade pulley
15. Saw table
16. Dial scale for tilt angle
17. Plastic table insert
18. Fixing handles for saw table
19. Setting handle for blade guide
20. Fixing handle for blade guide
21. Clip for parallel stop
22. Setting screw for upper blade pulley
23. Motor
24. Parallel stop

25. Machine frame
26. Blade
27. Mounting plate
28. Guide pin, top
29. Guide pin, bottom
30. Support bearing
31. Support bearing
32. Mount
33. Socket head screw
34. Blade guard
35. Socket head screw
36. Mount
37. Socket head screw
38. Socket head screw
39. Bar with scale, left
40. Bar with scale, right
41. Push stick
42. Push stick holder
43. Tensioning crank
44. Hexagon key set

- 101 Cross strut at top
- 102 Longitudinal strut at top
- 103 Cross strut at bottom
- 104 Longitudinal strut at bottom
- 105 Foot strut
- 106 Supporting foot
- 107 Cross bar

- a. Nut
- b. Spring washer
- c. Washer
- d. Screw
- e. Nut
- f. Spring washer
- g. Washer
- h. Round-head screws
- i. Nut
- j. Spring washer
- k. Washer
- l. Rubber foot
- m. Screw
- o. Socket head screw
- p. Washer
- q. Spring washer
- r. Nut

2.2 Items supplied

Please check that the article is complete as specified in the scope of delivery. If parts are missing, please contact our service center or the sales outlet where you made your purchase at the latest within 5 working days after purchasing the product and upon presentation of a valid bill of purchase. Also, refer to the warranty table in

the service information at the end of the operating instructions.

- Open the packaging and take out the equipment with care.
- Remove the packaging material and any packaging and/or transportation braces (if available).
- Check to see if all items are supplied.
- Inspect the equipment and accessories for transport damage.
- If possible, please keep the packaging until the end of the guarantee period.

Danger!

The equipment and packaging material are not toys. Do not let children play with plastic bags, foils or small parts. There is a danger of swallowing or suffocating!

- Bandsaw (machine frame)
- Saw table
- Mounting plate
- Bar with scale, left
- Bar with scale, right
- Push stick
- Hexagon wrench set
- Cross strut at top (2x)
- Longitudinal strut at top (2x)
- Cross strut at bottom (2x)
- Longitudinal strut at bottom (2x)
- Foot strut (4x)
- Rubber foot (4x)
- Supporting foot (2x)
- Cross bar
- Fastening materials
- Original operating instructions
- Safety information

3. Proper use

The bandsaw is designed to perform longitudinal and cross cuts on timber or wood-type materials. To cut round materials you must use suitable holding devices.

The equipment is to be used only for its prescribed purpose. Any other use is deemed to be a case of misuse. The user / operator and not the manufacturer will be liable for any damage or injuries of any kind caused as a result of this.

The machine is to be operated only with suitable saw blades. To use the machine properly you must also observe the safety regulations, the assembly instructions and the operating instructions to be found in this manual.

All persons who use and service the machine have to be acquainted with this manual and must be informed about the machine's potential hazards.

It is also imperative to observe the accident prevention regulations in force in your area.

The same applies for the general rules of occupational health and safety.

The manufacturer shall not be liable for any changes made to the machine nor for any damage resulting from such changes.

Even when the machine is used as prescribed it is still impossible to eliminate certain residual risk factors. The following hazards may arise in connection with the machine's construction and design:

- Damage to hearing if ear-muffs are not used as necessary.
- Harmful emissions of wood dust when used in closed rooms.
- Contact with the blade in the uncovered cutting zone.
- Injuries (cuts) when changing the blade.
- Injury from catapulted workpieces or parts of workpieces.
- Crushed fingers.
- Kickback.
- Tilting of the workpiece due to inadequate support.
- Touching the blade.
- Catapulting of pieces of timber and workpieces.

Please note that our equipment has not been designed for use in commercial, trade or industrial applications. Our warranty will be voided if the machine is used in commercial, trade or industrial businesses or for equivalent purposes.

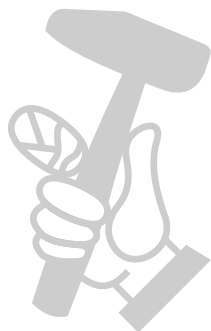

4. Technical data

Voltage:.....	220-240V ~ 50 Hz
Power:.....	750 W
Ideal speed n_0 :	1400 min ⁻¹
Blade length:.....	2320 mm
Blade width:.....	12.7 mm
Max. blade width:.....	12.7 mm
Blade speed 1:.....	800 m/min
Blade speed 2:.....	370 m/min
Cutting height:.....	170 mm / 90°
.....	75 mm / 45°
Throat:	305 mm
Table size:.....	495 x 390 mm
Tilting range of table:.....	0° to 45°
Workpiece size:.....	600 x 600 x 170 mm
Weight:.....	58 kg

Danger!

Sound and vibration

Sound and vibration values were measured in accordance with EN 61029.

L_{pA} sound pressure level	89.1 dB(A)
K_{pA} uncertainty	3 dB(A)
L_{WA} sound power level	98.1 dB(A)
K_{WA} uncertainty	3 dB(A)

Wear ear-muffs.

The impact of noise can cause damage to hearing.

Keep the noise emissions and vibrations to a minimum.

- Only use appliances which are in perfect working order.
- Service and clean the appliance regularly.
- Adapt your working style to suit the appliance.
- Do not overload the appliance.
- Have the appliance serviced whenever necessary.
- Switch the appliance off when it is not in use.

Caution!

Residual risks

Even if you use this electric power tool in accordance with instructions, certain residual risks cannot be ruled out. The following hazards may arise in connection with the equipment's construction and layout:

1. Lung damage if no suitable protective dust mask is used.

2. Damage to hearing if no suitable ear protection is used.

5. Before starting the equipment

Make sure the machine stands securely, i.e. bolt it to a workbench or solid base. There are two holes for this purpose in the machine foot.

- The saw table must be mounted correctly.
- All covers and safety devices have to be properly fitted before the machine is switched on.
- It must be possible for the blade to run freely.
- When working with wood that has been processed before, watch out for foreign bodies such as nails or screws etc.
- Before you actuate the On/Off switch, make sure that the saw blade is correctly fitted and that the machine's moving parts run smoothly.
- Before you connect the machine to the power supply, make sure the data on the rating plate is the same as that for your mains.

6. Assembly

CAUTION!

Pull out the power plug before carrying out any maintenance, resetting or assembly work on the bandsaw!

6.1 Assembling the base frame, fitting the machine to the base frame (Fig. 1a, 1e, 3a-3c)

Caution: Make allowance for the weight of the machine during the assembly work and arrange for another person to help!

- Use the round-head screws (h), spring washers (f), washers (g) and nuts (e) to screw-fit the cross struts (101) and the longitudinal struts (102) to the foot struts (105).
- Two of the foot struts (105) have additional holes for the supporting feet. Fit these foot struts with holes on the same long side of the base frame.
- Use the round-head screws (h), spring washers (f), washers (g) and nuts (e) to screw-fit the cross struts (103) and the longitudinal struts (104) to the foot struts (105).
- Use the screws (m), washers (k), spring washers (j) and nuts (i) to screw-fit the rubber feet (l) to the foot struts (105).
- Then turn the base frame around.
- Note: The distance between holes on the

front side of the base frame is different than on the rear side. Take care to position the machine frame correctly!

- Place the machine frame (25) on the base frame and use the screws (d), washers (c), spring washers (b) and nuts (a) to screw-fit the two components.
- Use the Socket head screws (o), washers (p), spring washers (q) and nuts (r) to screw-fit the supporting feet (106) to the foot struts (105). Then use the Socket head screws (o), washers (p), spring washers (q) and nuts (r) to join the two supporting feet to the cross bar (107).

6.1.2 Fitting the saw table (Fig. 4-5)

- Remove the bolt (4) by opening the groove in the saw table by levering and twisting simultaneously, e.g. with a screwdriver.
- Place the saw table (15) in its mount and secure it with the locking grip (18).
- Screw-fit the mounting plate and, if necessary, set the angle scale pointer precisely (see 6.6)
- Tap in the bolt so that it is flush with the table surface.
- Secure the bars with scale (39, 40) on the saw table. The zero position can be adjusted by shifting sideways.
- To disassemble, proceed in reverse order

6.2 Tensioning the blade (Fig. 1)

- **CAUTION!** Remove the tension from the blade if the bandsaw is not going to be used for some time. Be sure to re-tension the blade before you start the machine.
- Turn the tightening screw (9) for tensioning the blade (26) in a clockwise direction.
- The correct blade tension can be checked by applying pressure to the side of the blade with your finger, somewhere in the middle between the two blade pulleys (7 + 8). You should only be able to bend the blade (26) very slightly (approx. 1-2 mm).
- When the blade is tensioned enough, it will produce a metallic sound when tapped.
- Take the tension off the blade when you do not want to use it for some time; this will help to prevent overstretching.
- **IMPORTANT!** The blade may break if the tension is too high. **BEWARE OF INJURY!** If the tension is too low, the powered blade pulley (7) will spin while the blade does not move.

6.3 Adjusting the blade (Fig. 1a, 2)

- **CAUTION!** The blade tension has to be set correctly before you can adjust the blade.
- Undo the fasteners (13) and open the side cover (12).
- Slowly turn the upper blade pulley (8) clockwise by hand. The blade (26) should run in the middle of the pulley. If it does not, you will have to adjust the tilt of the upper blade pulley (8).
- If the blade (26) tends to run to the back of the blade pulley (8), i.e. towards the machine frame (25), turn the setting screw (22) anti-clockwise while turning the blade pulley (8) by hand until the blade (26) runs in the middle.
- If the blade (26) tends to run to the front edge of the blade pulley (8), turn the setting screw (22) in a clockwise direction.
- After setting the upper blade pulley (8) you need to check the blade (26) position on the lower blade pulley (7). The blade (26) should run in the middle of the blade pulley (7), as above. If it does not, you will have to adjust the tilt of the upper blade pulley (8) again.
- Turn the upper blade pulley several times until the adjustment to the upper blade pulley (8) has an effect on the blade position of the lower blade pulley (7).
- After any adjustments have been carried out, the side covers (12) must be closed again and re-secured with the fasteners (13).

6.4 Setting the blade guide (Fig. 7 - 10)

Whenever you change the blade you must re-set both the support bearings (30 + 31) and the guide pins (28 + 29).

- Undo the fasteners (13) and open the side cover (12).

6.4.1. Upper support bearing (30)

- Undo the screw (33).
- Move the support bearing (30) so that it is no longer touching the blade (26). There should be a maximum gap of 0.5 mm.
- Re-tighten the screw (33).

6.4.2. Adjusting the lower support bearing (31)

- Remove the saw table (15) or tilt it 45°.
- Swing the blade guard (34) away.
- Adjust in the same way that the upper support bearing was adjusted. The blade (26) is only supported by the support bearings (30 + 31) during cutting. When idle the blade should not touch the ball bearing.

6.4.3. Adjusting the upper guide pins (28)

- Undo the Socket head screw (35)
- Move the mount (36) of the guide pins (28) so that there is a gap of approx. 1 mm between the front edge of the guide pins (28) and the gullet of the blade in front.
- Re-tighten the Socket head screw (35).
- CAUTION! The blade will be rendered useless if the teeth touch the guide pins while the blade is running.
- Undo the Socket head screws (37).
- Move the guide pins (28) towards the blade so that there is a gap of approx. 0.5 mm between the guide pins (28) and the blade (26). The blade must not jam.
- Re-tighten the Socket head screws (37).
- Turn the upper blade pulley (8) several times in a clockwise direction.
- Check the setting of the guide pins (28) again and re-adjust if necessary.

6.4.4. Adjusting the lower guide pins (29)

- Dismantle the saw table (15).
- Undo the screw (33).
- Move the mount (32) of the guide pins (29) so that there is a gap of approx. 1 mm between the front edge of the guide pins (29) and the gullet of the blade in front.
- Re-tighten the screw (33).
- CAUTION! The blade will be rendered useless if the teeth touch the guide pins while the blade is running.
- Undo the screws (38).
- Move the guide pins (29) towards the blade so that there is a gap of approx. 0.5 mm between the guide pins (29) and the blade (26). The blade must not jam.
- Re-tighten the Socket head screws (38).
- Turn the lower blade pulley (7) several times in a clockwise direction.
- Check the setting of the guide pins (29) again and re-adjust if necessary.

CAUTION! When the adjustments have been finished, the blade guard (34) must be closed again.

6.5.1 Adjusting the upper blade guide (11) (Fig. 2, 9)

- Undo the fixing handle (20).
- Turn the setting wheel (19) to lower the blade guide (11) as close as possible to the workpiece to be cut. The gap should be approx. 2-3 mm.
- Re-tighten the fixing handle (20).

- Check the setting before each cut and re-adjust if necessary.

6.5.2 Adjusting the blade speed (Fig. 10, 11)

The bandsaw can be operated at two blade speeds.

To change the position proceed as follows:

- Slacken the drive belt (A) by turning the hand wheel (43) in an anticlockwise direction.
 - Move the belt to the desired position on the belt pulley (B) and the lower blade pulley (7).
 - Tension the drive belt (A) again by turning the hand wheel (43) in a clockwise direction.
- Important: Drive belts must not be tensioned too much.

6.6 Adjusting the machine table (15) to 90° (12/13)

- Move the upper blade guide (11) to the top.
- Undo the fixing handles (18).
- Place the angle (d) between the blade (26) and the table (15). The angle (d) is not included in delivery.
- Turn the setting wheel (19) to tilt the saw table (15) until it is at an angle of exactly 90° to the blade (26).
- Re-tighten the fixing handle (18).
- Undo the nut (49).
- Adjust the Socket head screw (50) until there is contact with the machine frame.
- Re-tighten the nut to fasten the Socket head screw.

Important: Never use warped or lacerated blades!

6.7 Changing the blade (Fig. 14)

- Move the blade guide (11) into a position approximately half way between the saw table (15) and the machine housing (25).
- Undo the fasteners (13) and open the side cover (12).
- Remove the bolt (4)
- Turn the tightening screw (9) anti-clockwise to remove the tension from the blade (26).
- Remove the blade (26) from the blade pulleys (7, 8) and take out through the slot in the table (15).
- Fit the new blade (26), aligned centrally on the blade pulleys (7, 8). The teeth of the blade (26) must point downwards in the direction of the table.
- Tension the blade (26) (see 6.2)
- Close the side cover (12) again.
- Refit the bolt (4)

6.8 Changing the rubber tires on the blade pulleys (Fig. 15)

After a certain time the rubber tires (3) on the blade pulleys (7/8) will get worn by the sharp teeth of the blades and must be replaced.

- Open the side cover (12).
- Remove the blade (26) (see 6.7).
- Lift the edge of the tire (3) with a small screwdriver (Z) and remove from the blade pulley (8).
- Repeat for the lower blade pulley (7).
- Fit the new tire (3), replace the blade (26) and close the side cover (12).

6.9 Changing the table insert (Fig. 16)

To prevent increased likelihood of injury the table insert (17) should be changed whenever it is worn or damaged.

- Detach the table (15) (see 6.1).
- Lift out the worn table insert (17).
- Fit the replacement table insert by following the above in reverse.

6.10 Extractor sockets (Fig. 2)

The bandsaw is equipped with extractor sockets (6) for extracting sawdust and chips.

6.11 Push stick holder (Fig. 6)

- When not in use, the push stick must always be kept on the holder.

7. Control elements

7.1 On/Off switch (Fig. 17)

- To turn the machine on, press the green button „1“.
- To turn the machine off again, press the red button „0“.
- Your bandsaw has a switch with undervoltage release. After a power failure you must re-activate the switch.

7.2 Parallel stop (Fig. 18a, 18b)

- Push the clip (21) on the parallel stop (24) upwards.
- Move the parallel stop (24) along the table (15), from either the right or left of the blade (26), and position as required.
- Press down the clamp lever (21) to secure the parallel stop (24). If the clamping force of the clamp lever (21) does not give enough hold, turn the clamp lever (21) several turns in clockwise direction until the parallel stop is

secured tightly enough.

- You must always ensure that the parallel stop (24) is positioned parallel to the blade (26).
- The parallel stop can be set in a high position (Fig. 18a) or low position (Fig. 18b) depending on the height of the workpiece.

7.3 Angular cuts (Fig. 2, 19)

To enable you to perform angular cuts parallel to the blade (26), the table (15) can be tilted forwards between 0° - 45°.

- Undo the fixing handles (18).
- Tilt the saw table (15) forwards until the required angle value is set on the dial scale (16).
- Re-tighten the fixing handles (18).
- Important: When the table (15) is tilted, place the parallel stop (24) to the right of the blade (26) looking in the direction in which you are working, on the side pointing downwards (provided the workpiece is wide enough) in order to stop the workpiece from slipping off.

8. Operation

Caution! After every new adjustment we recommend you to make a trial cut in order to check the new settings.

- For all cutting operations it is important to position the blade guide (11) as close as possible to the workpiece (see 6.5).
- Always guide the workpiece with both hands, holding it flat on the table (15) in order to prevent the blade (26) from jamming.
- Feed the workpiece at a uniform speed that enables the blade to cut through the material without difficulty and without blocking.
- Always use the parallel stop (24) on all cuts for which they are intended.
- Always aim at making a complete cut in one pass rather than in a stop-and-go operation requiring the workpiece to be withdrawn. If you have to withdraw the workpiece, switch off the bandsaw first and wait for the blade (26) to stop before freeing the workpiece.
- The workpiece must always be guided by the longer side during cutting.

8.1 Longitudinal cuts (Fig. 20)

Longitudinal cutting is when you use the saw to cut along the grain of the wood.

- Place the parallel stop (24) to the left of the blade (25), as far as possible, for the width required.

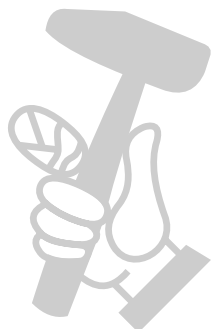

- Lower the blade guide (11) down to the workpiece (see 6.5).
- Switch on the saw.
- Press the edge of the workpiece with your right hand to hold it securely against the parallel stop (24) and flat on the table (15).
- Guide the workpiece along the parallel stop (24) and through the blade (26) at a uniform speed.
- Important: Long workpieces must be secured against falling off at the end of the cut (e.g. with a roller stand etc.)

Important! When handling narrower workpieces, it is essential to use a push stick. The push stick (41) must always be kept close at hand at the hook (42) provided for that purpose on the side of the saw.

8.2 Making angular cuts (Fig. 19)

- Set the saw table to the desired angle (see 7.3).
- Carry out the cut as described in 8.1.

8.3 Freehanded cuts (Fig. 21)

One of the most outstanding features of a bandsaw is the ease with which it allows you to make curved cuts and radii.

- Lower the blade guide (11) to the workpiece (see 6.5).
- Switch on the saw.
- Hold the workpiece securely on the table (15) and guide slowly through the blade (26).
- Freehanded cuts should be made at low feed speed so that you can guide the blade (26) along the required line.
- It often pays to first cut off surplus curves and corners up to about 6 mm from the cutting line.
- In the case of curves which are too tight for the blade to cut correctly, it can help to make a series of close-lying cuts at right angles to the curved line. When you saw the radius the material will simply drop off.

9. Transport

Caution: Make allowance for the weight of the machine when you move it and arrange for at least one other person to help!

To transport the bandsaw, hold the supporting foot (5) with one hand and the frame (25) with the other hand. Important! Never use guards to lift or transport the equipment.

10. Cleaning, maintenance and ordering of spare parts

Danger!

Always pull out the mains power plug before starting any cleaning work.

10.1 Cleaning

- Keep all safety devices, air vents and the motor housing free of dirt and dust as far as possible. Wipe the equipment with a clean cloth or blow it with compressed air at low pressure.
- We recommend that you clean the device immediately each time you have finished using it.
- Clean the equipment regularly with a moist cloth and some soft soap. Do not use cleaning agents or solvents; these could attack the plastic parts of the equipment. Ensure that no water can seep into the device. The ingress of water into an electric tool increases the risk of an electric shock.

10.2 Maintenance

There are no parts inside the equipment which require additional maintenance.

10.3 Ordering replacement parts:

Please quote the following data when ordering replacement parts:

- Type of machine
- Article number of the machine
- Identification number of the machine
- Replacement part number of the part required

For our latest prices and information please go to www.Einhell-Service.com

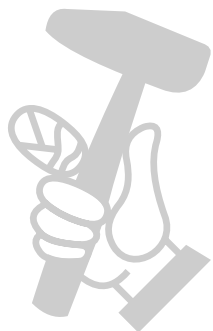

11. Disposal and recycling

The equipment is supplied in packaging to prevent it from being damaged in transit. The raw materials in this packaging can be reused or recycled. The equipment and its accessories are made of various types of material, such as metal and plastic. Never place defective equipment in your household refuse. The equipment should be taken to a suitable collection center for proper disposal. If you do not know the whereabouts of such a collection point, you should ask in your local council offices.

12. Storage

Store the equipment and accessories out of children's reach in a dark and dry place at above freezing temperature. The ideal storage temperature is between 5 and 30 °C. Store the electric tool in its original packaging.

Disposal

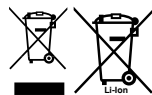

Power tools, rechargeable batteries, accessories and packaging should be sorted for environmental-friendly recycling.

Do not dispose of power tools and batteries/rechargeable batteries into household waste!

Only for EU countries:

According to the Directive 2012/19/EU on waste electrical and electronic equipment and its transposition into national law, power tools that are no longer usable, and, according to the Directive 2006/66/EC, defective or drained batteries must be collected separately and disposed of in an environmentally correct manner.

If disposed incorrectly, waste electrical and electronic equipment may have harmful effects on the environment and human health, due to the potential presence of hazardous substances.

Only for United Kingdom:

According to The Waste Electrical and Electronic Equipment Regulations 2013 (SI 2013/3113) (as amended) and the Waste Batteries and Accumulators Regulations 2009 (SI 2009/890) (as amended), products that are no longer usable must be collected separately and disposed of in an environmentally friendly manner.

The reprinting or reproduction by any other means, in whole or in part, of documentation and papers accompanying products is permitted only with the express consent of the Einhell Germany AG.

Subject to technical changes

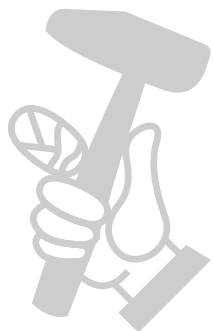

Service information

We have competent service partners in all countries named on the guarantee certificate whose contact details can also be found on the guarantee certificate. These partners will help you with all service requests such as repairs, spare and wearing part orders or the purchase of consumables.

Please note that the following parts of this product are subject to normal or natural wear and that the following parts are therefore also required for use as consumables.

Category	Example
Wear parts*	Guide roller, V-belt
Consumables*	Bandsaw blade
Missing parts	

* Not necessarily included in the scope of delivery!

In the effect of defects or faults, please register the problem on the internet at www.Einhell-Service.com. Please ensure that you provide a precise description of the problem and answer the following questions in all cases:

- Did the equipment work at all or was it defective from the beginning?
- Did you notice anything (symptom or defect) prior to the failure?
- What malfunction does the equipment have in your opinion (main symptom)? Describe this malfunction.

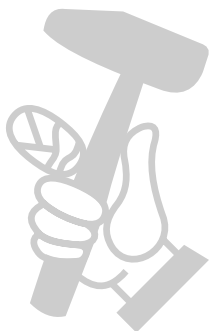

Warranty certificate

Dear Customer,

All of our products undergo strict quality checks to ensure that they reach you in perfect condition. In the unlikely event that this equipment develops a fault, please contact our service department at the address shown on this guarantee card. You can also contact us by telephone using the service number shown. Please note the following terms under which guarantee claims can be made:

1. These guarantee terms apply solely to consumers, i.e. natural persons, who do not want to use this product in connection with either their commercial or other self-employed activities. These guarantee terms regulate additional guarantee services which the undermentioned manufacturer promises to buyers of its new products in addition to their statutory rights of guarantee. Your statutory rights of guarantee are not affected by this guarantee. Our guarantee is free of charge to you.
2. The guarantee services cover only defects due to material or manufacturing faults on the new product which you have bought in the European Union from the undermentioned manufacturer and are limited to either the rectification of said defects or the replacement of the product, whichever we prefer. Please note that only equipment under the brand name "Professional" has been designed for use in commercial, trade or professional applications. For all other products the guarantee is invalidated if the equipment is used within the guarantee period in commercial, trade or industrial applications or for other equivalent activities.
3. Our guarantee does not cover:
 - Damage to the equipment caused by failure to comply with the installation/assembly instructions or by unprofessional installation; damage caused by failure to comply with the operating instructions (e.g. connection to the wrong mains voltage or current type); damage caused by failure to comply with the maintenance and safety regulations; damage caused by exposing the equipment to abnormal environmental conditions; damage resulting from poor care and maintenance.
 - Damage to the equipment caused by misuse or incorrect applications (e.g. overloading the equipment or using non-approved attachments or accessories); damage caused by foreign bodies (e.g. sand, stones, dust, ...) getting inside the equipment. Damage in transit; damage caused by force or external influences (e.g. by dropping the equipment).
 - Damage to the equipment or parts of the equipment which is owed to use-related, normal or otherwise natural wear. For example, batteries and battery packs are manufactured with a cycle limit for design-related reasons. Wear is negatively influenced in particular by load demands and charging speeds as well as exposure to heat, cold, vibration and impact.
4. The guarantee is valid for a period of 2 years starting from the purchase date of the equipment. Guarantee claims must be submitted before the end of the guarantee period and within two weeks of the defect being noticed. No guarantee claims will be accepted after the end of the guarantee period. The original guarantee period remains applicable to the equipment even if repairs are carried out or parts are replaced. In such cases, the work performed or parts fitted will not result in an extension of the guarantee period, and no new guarantee will become active for the work performed or for any replacement parts fitted. This also applies if on-site service is used.
5. To assert your guarantee claim, register the defective equipment at: www.Einhell-Service.com. You will need to provide proof of purchase of the new item of equipment. Equipment returned without such proof or without a rating plate are excluded from the guarantee services because of the lack of traceability. If the defect is covered by our guarantee, then either the item in question will be repaired immediately and returned to you or we will send you a new replacement.
6. If you have taken the equipment with you to a different EU country than where you bought it, we will arrange for a local service partner to provide the guarantee services. If you take the equipment outside the EU, the guarantee will not apply.

Of course, we are also happy to offer a chargeable repair service for any defects which are not covered or no longer covered by the scope of this guarantee. To take advantage of this service, please send the equipment to our service address. We draw attention to the restrictions of this guarantee concerning wear parts, consumables and missing parts as presented in the service information included in this operating manual.

Warrantor/ Service:

Einhell UK Ltd, Unit 10, 1st Floor, Champion's Business Park, Arrowe Brook Road, Upton, Wirral, CH49 0AB