



GP-LB 36/210 Li E-Solo

D	Originalbetriebsanleitung Akku-Laubbläser	SK	Originálny návod na obsluhu Akumulátorový fúkač lístia
GB	Original operating instructions Cordless Leaf Blower	NL	Originele handleiding Accu-bladblazer
F	Instructions d'origine Souffleur de feuilles sans fil	E	Manual de instrucciones original Soplador de hojas de batería
I	Istruzioni per l'uso originali Soffiatore per foglie	FIN	Alkuperäiskäyttöohje Akkukäyttöinen lehtipuhallin
DK/ N	Original betjeningsvejledning Akku-løvblæser	SLO	Originalna navodila za uporabo Akumulatorski puhalik za listje
S	Original-bruksanvisning Batteridrivnen lövbläsare	H	Eredeti használati utasítás Akkus-lombfúvó
CZ	Originální návod k obsluze Akumulátorový foukač listí		



Art.-Nr.: 34.336.20

I.-Nr.: 21021

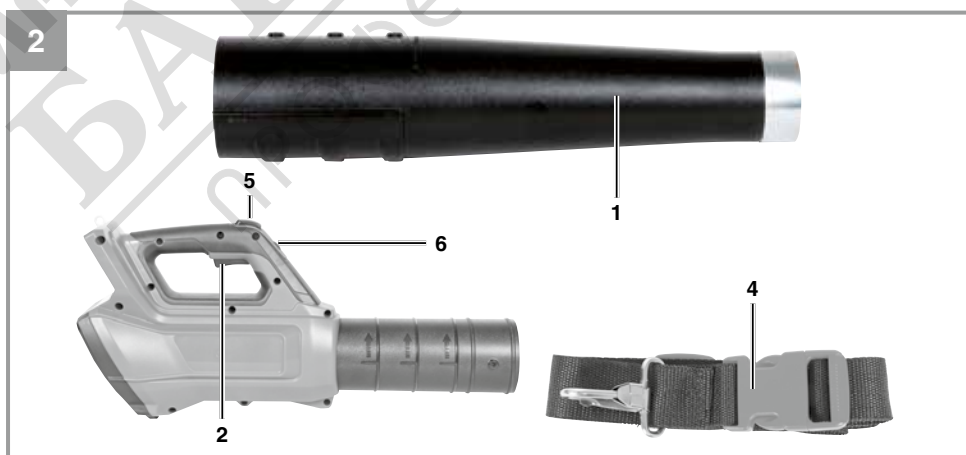

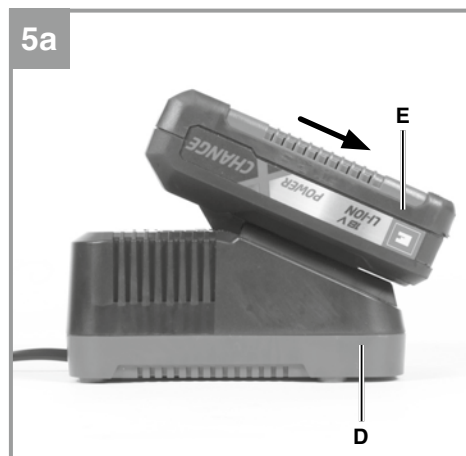
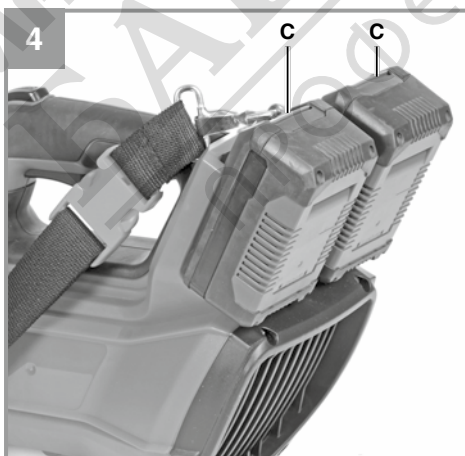
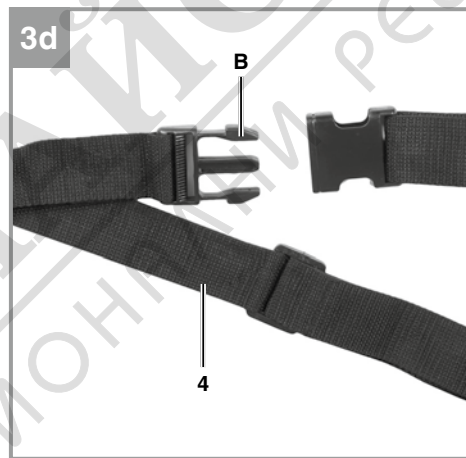
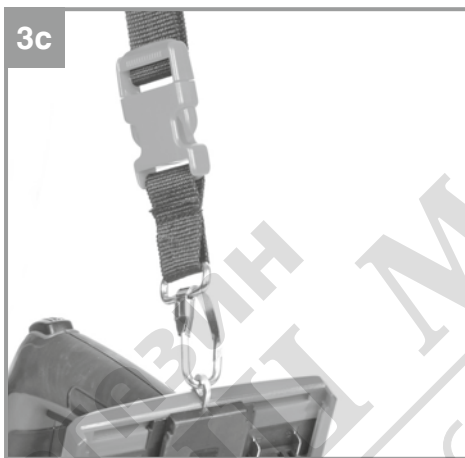
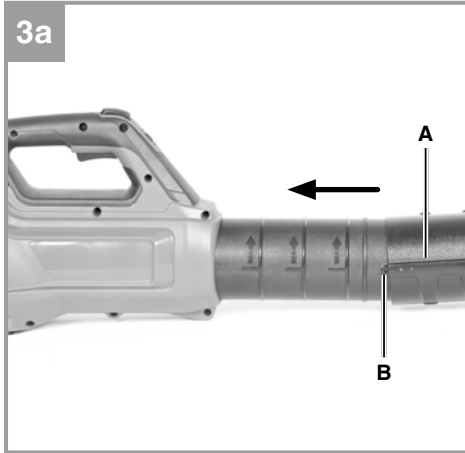

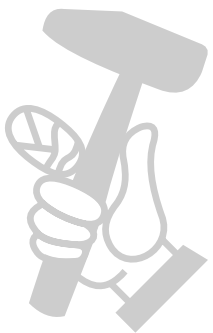
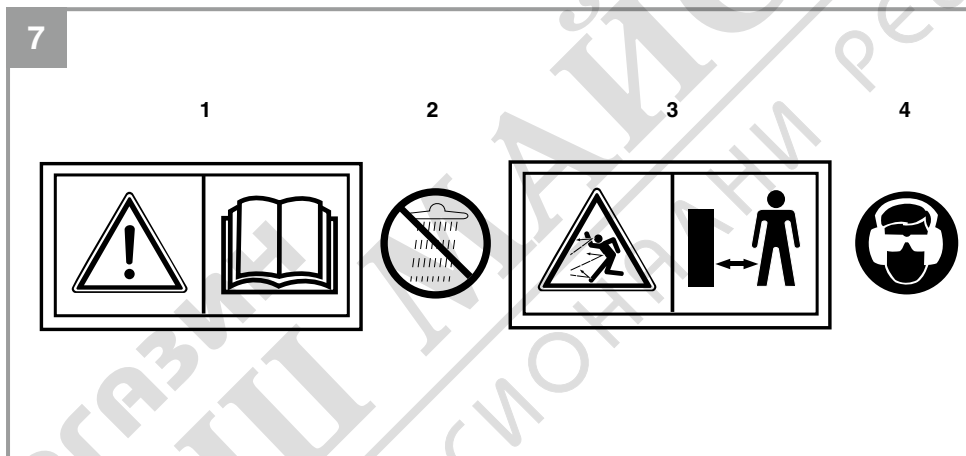
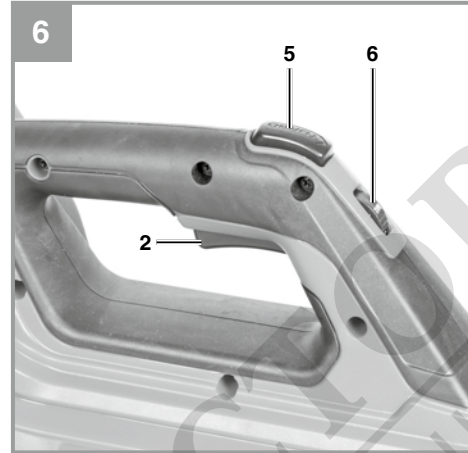
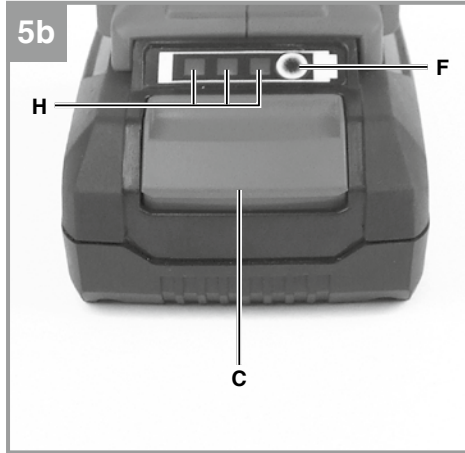

Danger!

When using the equipment, a few safety precautions must be observed to avoid injuries and damage. Please read the complete operating instructions and safety regulations with due care. Keep this manual in a safe place, so that the information is available at all times. If you give the equipment to any other person, hand over these operating instructions and safety regulations as well. We cannot accept any liability for damage or accidents which arise due to a failure to follow these instructions and the safety instructions.

1. Safety regulations

The corresponding safety information can be found in the enclosed booklet.

Danger!**Read all safety regulations and instructions.**

Any errors made in following the safety regulations and instructions may result in an electric shock, fire and/or serious injury.

Keep all safety regulations and instructions in a safe place for future use.

Explanation of the symbols used (see Fig. 7)

1. Read the directions for use before operating the tool.
2. Do not use the tool in rain or snow. Do not expose the tool to wet conditions.
3. Keep all other persons away from the danger zone.
4. Wear goggles and ear muffs.

2. Layout and items supplied**2.1 Layout (Fig. 1/2)**

1. Blower tube
2. On/Off switch
3. Engine unit
4. Harness
5. Turbo switch
6. Speed controller

2.2 Items supplied

Please check that the article is complete as specified in the scope of delivery. If parts are missing, please contact our service center or the nearest branch of the DIY store where you made your purchase at the latest within 5 work days after purchasing the article and upon presentation of a valid bill of purchase. Also, refer to the warranty

table in the warranty provisions at the end of the operating instructions.

- Open the packaging and take out the equipment with care.
- Remove the packaging material and any packaging and/or transportation braces (if available).
- Check to see if all items are supplied.
- Inspect the equipment and accessories for transport damage.
- If possible, please keep the packaging until the end of the guarantee period.

Danger!

The equipment and packaging material are not toys. Do not let children play with plastic bags, foils or small parts. There is a danger of swallowing or suffocating!

- Engine unit
- Blower tube
- Harness
- Original operating instructions
- Safety information

3. Proper use

The cordless leaf blower is designed to handle only foliage and garden refuse such as grass and small branches. Any other use is prohibited. Contact your local governmental agency for information regarding minimum age requirements for the operator.

The equipment is allowed to be used only for its prescribed purpose. Any other use is deemed to be a case of misuse. The user/operator and not the manufacturer will be liable for any damage or injuries of any kind resulting from such misuse.

Please note that our equipment has not been designed for use in commercial, trade or industrial applications. Our warranty will be voided if the equipment is used in commercial, trade or industrial businesses or for equivalent purposes.

4. Technical data

Idling speed n_0	10,000 – 22,300 rpm
Air speed max.	210 kph
Air volume max.	816 m ³ /h
Sound pressure level LpA	84.5 dB (A)
Uncertainty KpA	3 dB (A)
Measured sound power level LWA ..	93.28 dB(A)
KWA uncertainty	0.58 dB(A)
Guaranteed sound power level LWA	94 dB(A)
Vibration ah	1.615 m/s ²
Uncertainty K	1.0 m/s ²
Weight	2.5 kg

The machine may exceed 85 dB (A). The operator will require noise protection measures if this is the case.

The specified vibration value was established in accordance with a standardized testing method. It may change according to how the electric equipment is used and may exceed the specified value in exceptional circumstances.

The specified vibration value can be used for initial assessment of a harmful effect.

Important!

The vibration value changes according to the area of application of the electric equipment and may exceed the specified value in exceptional circumstances.

The equipment, which is supplied without batteries and without a charger, is allowed to be used only with the lithium-ion batteries of the Power-X-Change series!

The lithium-ion batteries of the Power-X-Change series are allowed to be charged only with the Power-X charger.

Keep the noise emissions and vibrations to a minimum.

- Only use appliances which are in perfect working order.
- Service and clean the appliance regularly.
- Adapt your working style to suit the appliance.
- Do not overload the appliance.
- Have the appliance serviced whenever necessary.
- Switch the appliance off when it is not in use.
- Wear protective gloves.

Caution!

Residual risks

Even if you use this electric power tool in accordance with instructions, certain residual risks cannot be ruled out. The following hazards may arise in connection with the equipment's construction and layout:

1. Lung damage if no suitable protective dust mask is used.
2. Damage to hearing if no suitable ear protection is used.

5. Before starting the equipment

Caution!

The equipment is supplied without batteries and without a charger is allowed to be used only with the lithium-ion batteries of the Power-X-Change series!

The lithium-ion batteries of the Power-X-Change series are allowed to be charged only with the Power-X charger.

Warning!

Always remove the battery pack before making adjustments to the blower tube.

5.1 Fitting the blower tube (Fig. 3a/b)

There are three settings for adjusting the length of the blower tube to your requirements. To do so, attach the blower tube to the motor unit. The groove (A) must be pushed into the guide (B) when you do this. When the blower tube has reached one of the three end points on the motor unit, turn it to the right to secure it in position on the motor unit.

Important! The tube must be turned as far as it will go to make sure it is firmly securely in position.

5.2 Fitting the battery pack (Fig. 4)

Press the pushlock button of the battery pack as shown in Fig. 4 and push the battery pack into the mount provided. When the battery pack is positioned as in Fig. 4, make sure that the pushlock button latches in place! To remove the battery pack, proceed in reverse order.

Important!

Use only batteries which are charged to the same level. Never combine full and half-full batteries.

Always charge the two batteries simultaneously. The equipment's operating time depends on the battery with the lower charge level. The two batteries must always be fully charged before use.

5.3 Charging the battery (Fig. 5a)

1. Take the battery pack out of the equipment. Do this by pressing the pushlock button.
2. Check that your mains voltage is the same as that marked on the rating plate of the battery charger. Insert the power plug of the charger (D) into the socket outlet. The green LED will then begin to blink.
3. Insert the battery pack (E) into the charger (D).
4. In section 11. „Charger indicator“ you will find a table with an explanation of the LED indicator on the charger.

The battery pack can become a little warm during the charging. This is normal.

If the battery pack fails to charge, check:

- whether there is voltage at the socket outlet
- whether there is good contact at the charging contacts

If the battery pack still fails to charge, send

- the charging unit
- and the battery pack

to our customer service center.

To ensure that items are properly packaged and delivered when you send them to us, please contact our customer service or the point of sale at which the equipment was purchased.

When shipping or disposing of batteries and cordless tools, always ensure that they are packed individually in plastic bags to prevent short circuits and fires.

To ensure that the battery pack provides long service, you should take care to recharge it promptly. You must recharge the battery pack when you notice that the performance of the device drops. Never allow the battery pack to become fully discharged. This will cause it to develop a defect.

5.4 Battery capacity indicator (Fig. 5b)

Press the button for the battery capacity indicator (F). The battery capacity indicator (H) will indicate the charge status of the battery by means of 3 LEDs.

All 3 LEDs are lit:

The battery is fully charged.

2 or 1 LED(s) are lit:

The battery has an adequate remaining charge.

1 LED blinks:

The battery is empty, recharge the battery.

All LEDs blink:

The battery temperature is too low. Remove the battery from the equipment, keep it at room temperature for one day. If the fault reoccurs, this means that the rechargeable battery has undergone exhaustive discharge and is defective. Remove the battery from the equipment. Never use or charge a defective battery.

Important!

The equipment's operating time depends on the battery with the lower charge level or lower capacity (Ah). Therefore, only use rechargeable batteries which are charged to the same level and have the same capacity (Ah). Never combine full and half-full batteries or batteries with different capacities (Ah). Always charge the two batteries simultaneously before starting to use them.

5.5 Fitting the harness (Fig. 3c/3d)

Fasten the harness to the eyelet on the motor housing. Place the harness over your shoulder and adjust the length to that you can guide the equipment comfortably.

Caution: Carry the harness so that the click fastener is always within reach. In an emergency you can quickly remove the equipment by opening the click fastener (Fig. 3d / Item B).

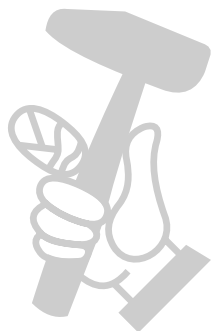

6. Operation

6.1 Switching on the equipment (Fig. 6)

- To switch on, press and hold the On/Off switch (2).
- To switch off, let go of the On/Off switch.
- Channel the air stream forward and walk slowly to blow foliage or garden refuse into a pile or to clear out hard-to-reach places.

6.2. Speed control (Fig. 6)

The equipment is fitted with an electronic speed controller. To use it, turn the speed controller (Fig. 6/Item 6) to the desired position. Use the equipment only with the speed which is actually required and never let it run at a speed which is faster than necessary.

6.3 Turbo mode (Fig. 6)

If you need more blowing power, e.g. to blow away piles of wet foliage, you can press the turbo button (Fig. 6 / Item 5). Pressing the turbo button will raise the speed and therefore the blowing power temporarily.

Important: To reduce noise and prolong battery operating time, never actuate the turbo button longer than necessary.

7. Cleaning, maintenance and ordering of spare parts

Danger!

Always remove the batteries before you carry out any cleaning work.

7.1 Cleaning

- Keep all safety devices, air vents and the motor housing free of dirt and dust as far as possible. Wipe the equipment with a clean cloth or blow it with compressed air at low pressure.
- We recommend that you clean the device immediately each time you have finished using it.
- Clean the equipment regularly with a moist cloth and some soft soap. Do not use cleaning agents or solvents; these could attack the plastic parts of the equipment. Ensure that no water can seep into the device. The ingress of water into an electric tool increases the risk of an electric shock.

7.2 Maintenance

- Should the tool experience problems beyond those mentioned above, let only an authorised professional or a customer service shop perform an inspection.
- There are no other parts inside the equipment which require maintenance.

7.3 Ordering replacement parts:

Please quote the following data when ordering replacement parts:

- Type of machine
- Article number of the machine
- Identification number of the machine
- Replacement part number of the part required

For our latest prices and information please go to www.Einhell-Service.com

8. Faults

The equipment does not work:

Check that the battery is charged and whether the charging unit is working. If the equipment will not work in spite of the voltage supply being OK, please send it to the customer service address below.

9. Disposal and recycling

The equipment is supplied in packaging to prevent it from being damaged in transit. The raw materials in this packaging can be reused or recycled. The equipment and its accessories are made of various types of material, such as metal and plastic. Never place defective equipment in your household refuse. The equipment should be taken to a suitable collection center for proper disposal. If you do not know the whereabouts of such a collection point, you should ask in your local council offices.

10. Storage

Store the equipment and accessories out of children's reach in a dark and dry place at above freezing temperature. The ideal storage temperature is between 5 and 30 °C. Store the electric tool in its original packaging.

11 Charger indicator

Indicator status		Explanations and actions
Red LED	Green LED	
Off	Flashing	<p>Ready for use The charger is connected to the mains and is ready for use; there is no battery pack in the charger</p>
On	Off	<p>Charging The charger is charging the battery pack in quick charge mode. The charging times are shown directly on the charger. Important! The actual charging times may vary slightly from the stated charging times depending on the existing battery charge.</p>
Off	On	<p>The battery is charged and ready for use. The unit then changes over to gentle charging mode until the battery is fully charged. To do this, leave the rechargeable battery on the charger for approx. 15 minutes longer. Action: Take the battery pack out of the charger. Disconnect the charger from the mains supply.</p>
Flashing	Off	<p>Adapted charging The charger is in gentle charging mode. For safety reasons the charging is performed less quickly and takes more time. The reasons can be: - The rechargeable battery has not been used for a very long time. - The battery temperature is outside the ideal range. Action: Wait for the charging to be completed; you can still continue to charge the battery pack.</p>
Flashing	Flashing	<p>Fault Charging is no longer possible. The battery pack is defective. Action: Never charge a defective battery pack. Take the battery pack out of the charger.</p>
On	On	<p>Temperature fault The battery pack is too hot (e.g. due to direct sunshine) or too cold (below 0° C). Action: Remove the battery pack and keep it at room temperature (approx. 20° C) for one day .</p>



For EU countries only

Never place any electric power tools in your household refuse.

To comply with European Directive 2012/19/EC concerning old electric and electronic equipment and its implementation in national laws, old electric power tools have to be separated from other waste and disposed of in an environment-friendly fashion, e.g. by taking to a recycling depot.

Recycling alternative to the return request:

As an alternative to returning the equipment to the manufacturer, the owner of the electrical equipment must make sure that the equipment is properly disposed of if he no longer wants to keep the equipment. The old equipment can be returned to a suitable collection point that will dispose of the equipment in accordance with the national recycling and waste disposal regulations. This does not apply to any accessories or aids without electrical components supplied with the old equipment.

The reprinting or reproduction by any other means, in whole or in part, of documentation and papers accompanying products is permitted only with the express consent of the Einhell Germany AG.

Subject to technical changes

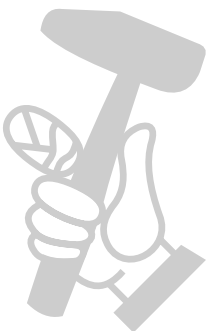

Service information

We have competent service partners in all countries named on the guarantee certificate whose contact details can also be found on the guarantee certificate. These partners will help you with all service requests such as repairs, spare and wearing part orders or the purchase of consumables.

Please note that the following parts of this product are subject to normal or natural wear and that the following parts are therefore also required for use as consumables.

Category	Example
Wear parts*	Battery
Consumables*	
Missing parts	

* Not necessarily included in the scope of delivery!

In the effect of defects or faults, please register the problem on the internet at www.Einhell-Service.com. Please ensure that you provide a precise description of the problem and answer the following questions in all cases:

- Did the equipment work at all or was it defective from the beginning?
- Did you notice anything (symptom or defect) prior to the failure?
- What malfunction does the equipment have in your opinion (main symptom)? Describe this malfunction.

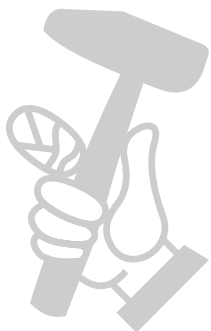

Warranty certificate

Dear Customer,

All of our products undergo strict quality checks to ensure that they reach you in perfect condition. In the unlikely event that your device develops a fault, please contact our service department at the address shown on this guarantee card. You can also contact us by telephone using the service number shown. Please note the following terms under which guarantee claims can be made:

1. These guarantee terms apply to consumers only, i.e. natural persons intending to use this product neither for their commercial activities nor for any other self-employed activities. These warranty terms regulate additional warranty services, which the manufacturer mentioned below promises to buyers of its new products in addition to their statutory rights of guarantee. Your statutory guarantee claims are not affected by this guarantee. Our guarantee is free of charge to you.
2. The warranty services cover only defects due to material or manufacturing faults on a product which you have bought from the manufacturer mentioned below and are limited to either the rectification of said defects on the product or the replacement of the product, whichever we prefer.
Please note that our devices are not designed for use in commercial, trade or professional applications. A guarantee contract will not be created if the device has been used by commercial, trade or industrial business or has been exposed to similar stresses during the guarantee period.
3. The following are not covered by our guarantee:
 - Damage to the device caused by a failure to follow the assembly instructions or due to incorrect installation, a failure to follow the operating instructions (for example connecting it to an incorrect mains voltage or current type) or a failure to follow the maintenance and safety instructions or by exposing the device to abnormal environmental conditions or by lack of care and maintenance.
 - Damage to the device caused by abuse or incorrect use (for example overloading the device or the use of unapproved tools or accessories), ingress of foreign bodies into the device (such as sand, stones or dust, transport damage), the use of force or damage caused by external forces (for example by dropping it).
 - Damage to the device or parts of the device caused by normal or natural wear or tear or by normal use of the device.
4. The guarantee is valid for a period of 24 months starting from the purchase date of the device. Guarantee claims should be submitted before the end of the guarantee period within two weeks of the defect being noticed. No guarantee claims will be accepted after the end of the guarantee period. The original guarantee period remains applicable to the device even if repairs are carried out or parts are replaced. In such cases, the work performed or parts fitted will not result in an extension of the guarantee period, and no new guarantee will become active for the work performed or parts fitted. This also applies if an on-site service is used.
5. To make a claim under the guarantee, please register the defective device at: www.Einhell-Service.com. Please keep your bill of purchase or other proof of purchase for the new device. Devices that are returned without proof of purchase or without a rating plate shall not be covered by the guarantee, because appropriate identification will not be possible. If the defect is covered by our guarantee, then the item in question will either be repaired immediately and returned to you or we will send you a new replacement.

Of course, we are also happy offer a chargeable repair service for any defects which are not covered by the scope of this guarantee or for units which are no longer covered. To take advantage of this service, please send the device to our service address.

Also refer to the restrictions of this warranty concerning wear parts, consumables and missing parts as set out in the service information in these operating instructions.

