



GC-CH 1846 Li GC-CH 1846 Li Kit

D	Originalbetriebsanleitung Akku-Heckenschere	FIN	Alkuperäiskäyttöohje Akkukäyttöiset pensassakset
GB	Original operating instructions Cordless hedge trimmer	SLO	Originalna navodila za uporabo Baterijske škarje za živo mejo
F	Instructions d'origine Taille-haies a accumulateur	H	Eredeti használati utasítás Akku-kerti olló
I	Istruzioni per l'uso originali Cesoie per siepi a batteria	RO	Instrucțiuni de utilizare originale Foarfece pentru gard viu cu acumulator
DK/ N	Original betjeningsvejledning Akku-hækkeklipper	GR	Πρωτότυπες Οδηγίες χρήσης Θαμνοκοπτης μπαταρίας
S	Original-bruksanvisning Batteridrivnen häcksax	P	Manual de instrucções original Corta-sebes sem fio
CZ	Originální návod k obsluze Akumulátorové plotové nůžky	HR/ BIH	Originalne upute za uporabu Akumulatorske škare za živicu
SK	Originálny návod na obsluhu Akumulátorové záhradnícke nožnice	RS	Originalna uputstva za upotrebu Akumulatorske makaze za živicu
NL	Originele handleiding Accuheggschaar	PL	Instrukcją oryginalną Akumulatorowe nożyce
E	Manual de instrucciones original Tijeras recortasetos de pilas recargables	TR	Orijinal Kullanma Talimatı Şarjlı çit makası

13



Art.-Nr.: 34.106.42
Art.-Nr.: 34.106.83 (1x 2,0 Ah)

I.-Nr.: 21041
I.-Nr.: 21041

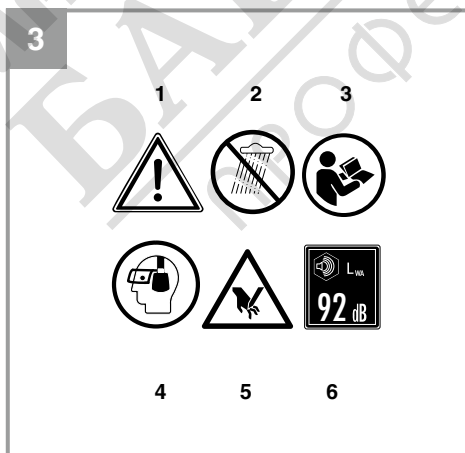
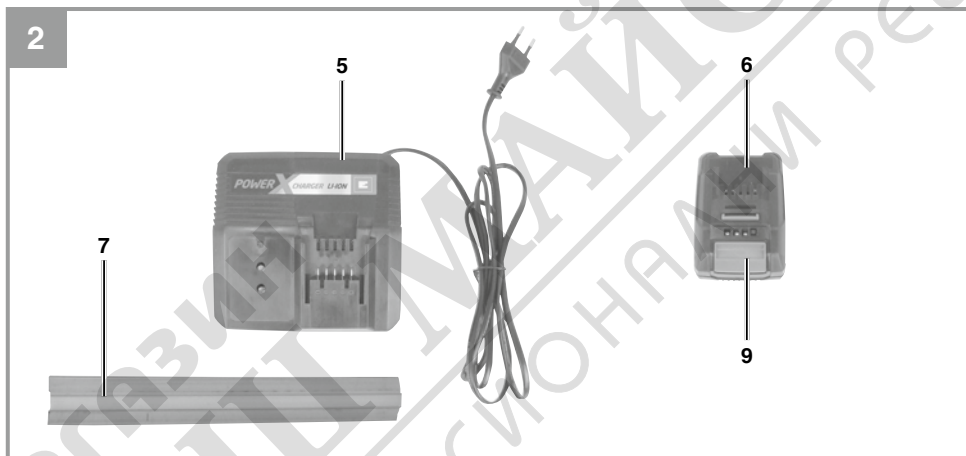
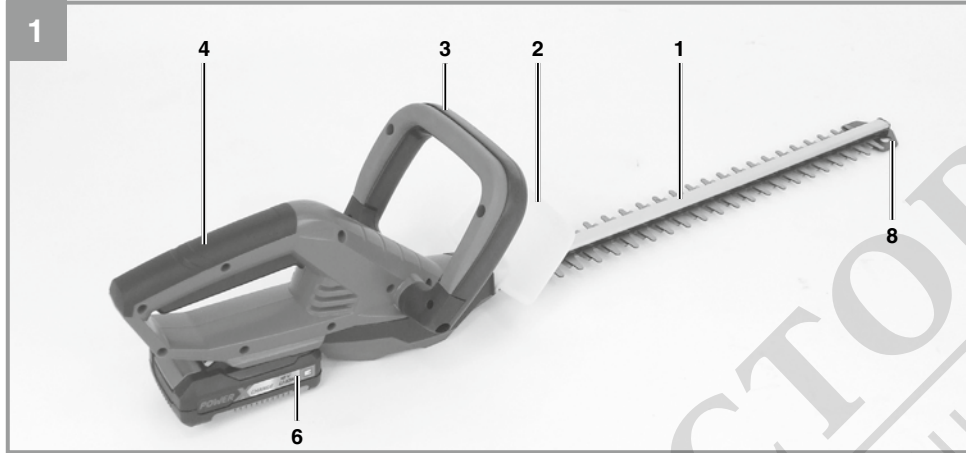

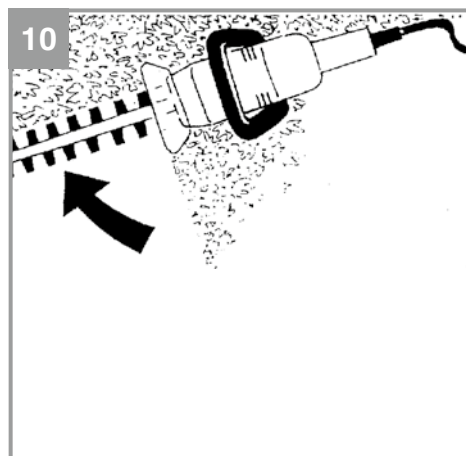
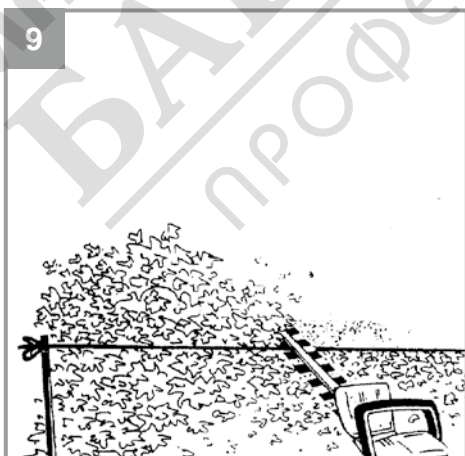
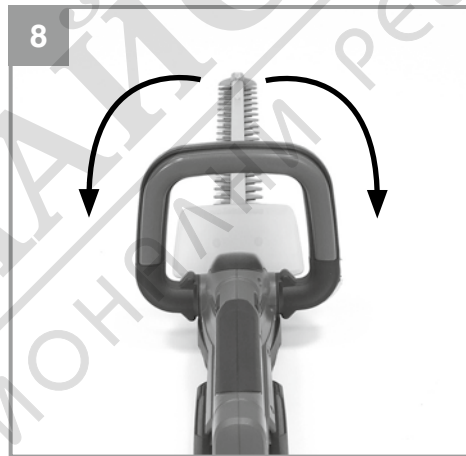
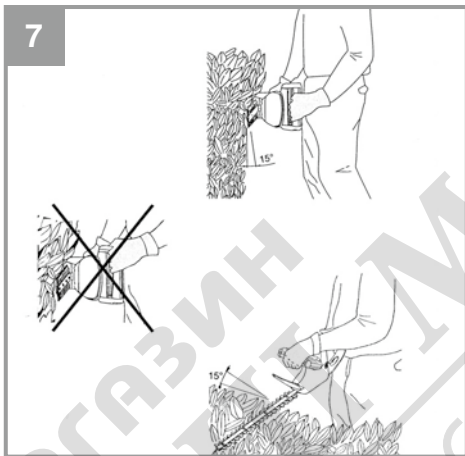
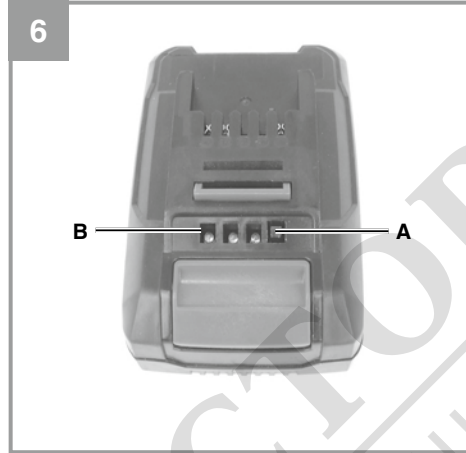
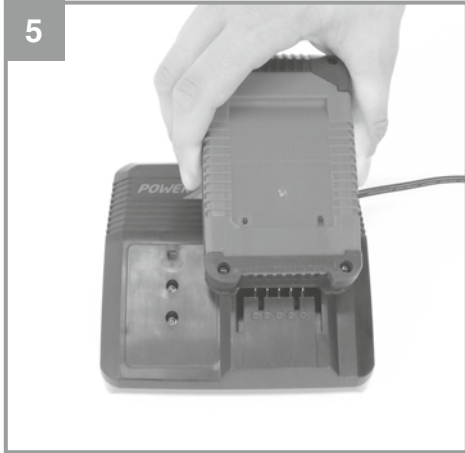

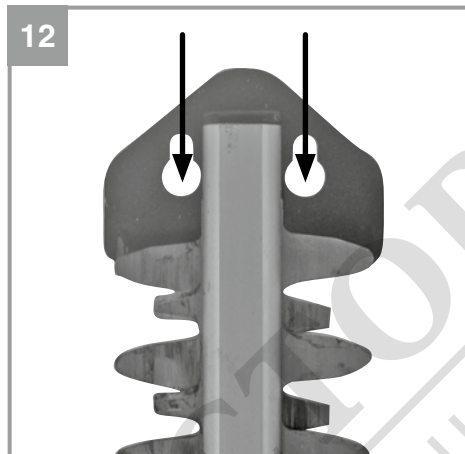
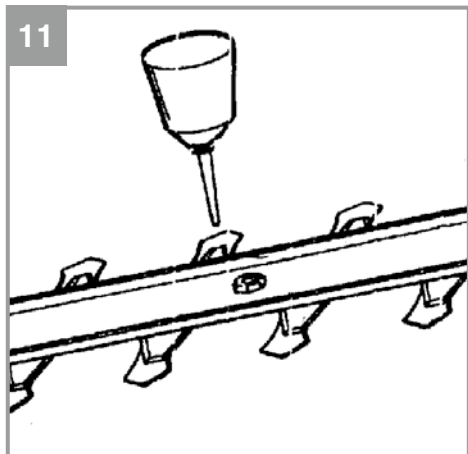

МАГАЗИН МАЙСТОР
БАШ МАЙСТОР
ПРОФЕСІОНАЛНИ РЕШЕННЯ

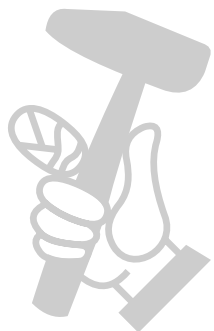

Danger!

When using the equipment, a few safety precautions must be observed to avoid injuries and damage. Please read the complete operating instructions and safety regulations with due care. Keep this manual in a safe place, so that the information is available at all times. If you give the equipment to any other person, hand over these operating instructions and safety regulations as well. We cannot accept any liability for damage or accidents which arise due to a failure to follow these instructions and the safety instructions.

Explanation of the warning signs on the machine (Figure 3)

1. Warning!
2. Do not expose the hedge trimmer to rain or wet conditions!
3. Read the instructions for use before use!
4. Wear eye protection and ear plugs!
5. **Danger!** Moving blade. Keep hands and feet away from the blade.
6. Guaranteed sound power level

1. Safety regulations

The corresponding safety information can be found in the enclosed booklet.

Warning!

Read all the safety information, instructions, illustrations and technical data provided on or with this power tool. Failure to adhere to the following instructions may result in electric shock, fire and/or serious injury.

Keep all the safety information and instructions in a safe place for future use.

2. Layout and items supplied**2.1 Layout (Fig. 1/2)**

1. Cutter rail
2. Hand guard
3. Steady grip with button switch
4. Handle with button switch
5. Battery charger
6. Battery pack
7. Cutter guard
8. Impact guard
9. Lock for battery

2.2 Items supplied

Please check that the article is complete as specified in the scope of delivery. If parts are missing, please contact our service center or the sales outlet where you made your purchase at the latest within 5 working days after purchasing the product and upon presentation of a valid bill of purchase. Also, refer to the warranty table in the service information at the end of the operating instructions.

- Open the packaging and take out the equipment with care.
- Remove the packaging material and any packaging and/or transportation braces (if available).
- Check to see if all items are supplied.
- Inspect the equipment and accessories for transport damage.
- If possible, please keep the packaging until the end of the guarantee period.

Danger!

The equipment and packaging material are not toys. Do not let children play with plastic bags, foils or small parts. There is a danger of swallowing or suffocating!

- Hedge trimmer
- Cutter guard
- Battery (not included with Art. No. 34.106.42)
- Charger (not included with Art. No. 34.106.42)
- Original operating instructions
- Safety instructions

3. Proper use

This hedge trimmer is suitable for cutting hedges, bushes and shrubs.

The equipment is to be used only for its prescribed purpose. Any other use is deemed to be a case of misuse. The user / operator and not the manufacturer will be liable for any damage or injuries of any kind caused as a result of this.

Please note that our equipment has not been designed for use in commercial, trade or industrial applications. Our warranty will be voided if the machine is used in commercial, trade or industrial businesses or for equivalent purposes.

4. Technical data

Cutter rail length	520 mm
Cutting length	460 mm
Tooth spacing	15 mm
Cuts/min	2200
Sound pressure level, L_{pA}	80,7 dB (A)
Uncertainty K_{pA}	3 dB
Sound power level, L_{WA}	88.7 dB (A)
K_{WA} uncertainty	3.6 dB
Interchangeable battery	18 V d.c. / 2000 mAh
Sound power level guaranteed L_{WA}	92 dB(A)
Vibration a_{hv}	$\leq 2.5 \text{ m/s}^2$
K uncertainty	1.5 m/s^2
Weight	2.0 kg

Battery charger

Mains voltage	200-250 V ~ 50-60 Hz
Output voltage/current	20 V d. c. / 3 A

Wear ear-muffs.

The impact of noise can cause damage to hearing.

Total vibration values (vector sum of three directions) determined in accordance with EN 62841.

The stated vibration emission levels and stated noise emission values were measured in accordance with a set of standardized criteria and can be used to compare one power tool with another.

The stated vibration emission levels and stated noise emission values can also be used to make an initial assessment of exposure.

Warning:

The vibration and noise emission levels may vary from the level specified during actual use, depending on the way in which the power tool is used, especially the type of workpiece it is used for.

Keep the noise emissions and vibrations to a minimum.

- Only use appliances which are in perfect working order.
- Service and clean the appliance regularly.
- Adapt your working style to suit the appliance.
- Do not overload the appliance.
- Have the appliance serviced whenever necessary.

- Switch the appliance off when it is not in use.
- Wear protective gloves.

Caution!

Residual risks

Even if you use this electric power tool in accordance with instructions, certain residual risks cannot be ruled out. The following hazards may arise in connection with the equipment's construction and layout:

1. Lung damage if no suitable protective dust mask is used.
2. Damage to hearing if no suitable ear protection is used.
3. Health damage caused by hand-arm vibrations if the equipment is used over a prolonged period or is not properly guided and maintained.

Limit the operating time!

All stages of the operating cycle must be considered (for example, times in which the electric tools are switched off and times in which the tool is switched on but operates without load).

5. Before starting the equipment

5.1 Installing the battery (Fig. 4)

Press the side pushlock buttons of the battery pack as shown in Fig. 4 and push the battery pack into the mount provided. When the battery pack is positioned as in Fig. 1, make sure that the pushlock buttons latch in place! To remove the battery pack, proceed in reverse order.

5.2 Charging the battery (Fig. 5)

1. Take the battery pack out of the equipment. Do this by pressing the pushlock buttons (Figure 2/Item 9).
2. Check that your mains voltage is the same as that marked on the rating plate of the battery charger. Insert the power plug of the charger (5) into the mains socket outlet. The green LED will then begin to flash.
3. Insert the battery pack (6) into the battery charger (5).
4. In section "Charger indicator" you will find a table with an explanation of the LED indicator on the charger.

The battery pack can become a little warm during the charging. This is normal.

If the battery pack fails to charge, check:

- whether there is voltage at the socket outlet
- whether there is good contact at the charging contacts

If the battery pack still fails to charge, send

- the charging unit
 - and the battery pack
- to our customer service center.

To ensure that items are properly packaged and delivered when you send them to us, please contact our customer service or the point of sale at which the equipment was purchased.

When shipping or disposing of batteries and cordless tools, always ensure that they are packed individually in plastic bags to prevent short circuits and fires.

To ensure that the battery pack provides long service, you should take care to recharge it promptly. You must recharge the battery pack when you notice that the performance of the device drops. Never allow the battery pack to become fully discharged. This will cause it to develop a defect. vice, you should take care to recharge it promptly. You must recharge the battery pack when you notice that the power of the cordless hedge trimmer drops. Never fully discharge the battery pack. This will cause it to develop a defect.

5.3 Battery capacity indicator (Fig. 6)

Press the button for the battery capacity indicator (Item A). The battery capacity indicator (Item B) shows the charge status of the battery using 3 LEDs.

All 3 LEDs are lit:

The battery is fully charged.

2 or 1 LED(s) are lit:

The battery has an adequate remaining charge.

1 LED flashes:

The battery is empty, recharge the battery.

All LEDs blink:

The battery temperature is too low. Remove the battery from the equipment, keep it at room temperature for one day. If the fault reoccurs, this means that the rechargeable battery has undergone exhaustive discharge and is defective. Remove the battery from the equipment. Never use or

charge a defective battery.

6. Operation

Switching ON/OFF.

The hedge trimmer is equipped with a two-handed safety switch. The machine works only when the switch on the steady grip (Figure 1 / Item 3) is pressed with one hand and the switch on the handle (Figure 1 / Item 4) is pressed with the other hand. If either switch is released, the cutters will stop moving. Please watch out for the cutters as they slow down to a standstill.

Notes on working practice

- A hedge trimmer can be used to cut shrubs and bushes as well as hedges.
- To obtain the best cutting results, hold the hedge trimmer so that the cutter teeth are at an angle of approx. 15° in relation to the hedge (see Figure 7).
- The twin-bladed cutters rotate in opposite directions, thus enabling cutting in both directions (see Figure 8).
- It is recommended to tie a guide line of string or the like along the hedge so that you cut the hedge to a level height. Cut off all branches which protrude beyond the guide line (see Figure 9).

Warning! Be particularly attentive when cutting along the guide line. Do not cut through the guide line. This could get entangled in the blades and lead to injuries or damage to property.

- Cut the sides of the hedge with curve-shaped movements from the bottom up (see Figure 10).

What to do if the blade gets blocked

1. Stop the equipment.
2. Remove the battery.
3. Remove the jammed material from the blade (wear work gloves to prevent injury when you do so).

After using

1. Switch off the equipment.
2. Remove the battery.
3. Allow the equipment to cool down and then store it out of children's reach.

7. Cleaning, maintenance and ordering of spare parts

Danger!

Turn off and remove the rechargeable battery from the hedge trimmer, before putting down or cleaning.

7.1 Cleaning

- Keep all safety devices, air vents and the motor housing free of dirt and dust as far as possible. Wipe the equipment with a clean cloth or blow it with compressed air at low pressure.
- We recommend that you clean the device immediately each time you have finished using it.
- Clean the equipment regularly with a moist cloth and some soft soap. Do not use cleaning agents or solvents; these could attack the plastic parts of the equipment. Ensure that no water can seep into the device. The ingress of water into an electric tool increases the risk of an electric shock.
- Remove deposits from the guard hood with a brush.

7.2 Maintenance

- The cutters should be cleaned and lubricated at regular intervals in order to ensure best performance at all times. Remove deposits with a brush and apply a thin film of oil (Figure 11).
- There are no parts inside the equipment which require additional maintenance.
- For storage, the hedge trimmer can be hung up on a nail, screw or similar in a borehole on the impact guard, with blade guard mounted (Fig. 12)

7.3 Storage

- For storage, the hedge trimmer can be hung up on a nail, screw or similar in a borehole on the impact guard, with blade guard mounted (Fig. 12)

7.4 Ordering replacement parts:

Please quote the following data when ordering replacement parts:

- Type of machine
 - Article number of the machine
 - Identification number of the machine
 - Replacement part number of the part required
- For our latest prices and information please go to www.Einhell-Service.com

8. Disposal and recycling

The equipment is supplied in packaging to prevent it from being damaged in transit. The raw materials in this packaging can be reused or recycled. The equipment and its accessories are made of various types of material, such as metal and plastic. Never place defective equipment in your household refuse. The equipment should be taken to a suitable collection center for proper disposal. If you do not know the whereabouts of such a collection point, you should ask in your local council offices.

9. Storage

- Remove the rechargeable battery/batteries.
- Clean and maintain the equipment before putting it into storage
- Store the equipment and accessories in a dark and dry place at above freezing temperature. The ideal storage temperature is between 5 and 30 °C. Store the electric tool in its original packaging.
- Use the cutter rail guard

10. Transport

Remove the rechargeable battery/batteries. Secure the equipment during transportation in order to prevent damage or injuries. Use the cutter rail guard.

11. Faults

The device does not operate:

Check whether the rechargeable battery is charged and whether the battery charger works. If the device still does not work even with a voltage supply, please send it to our customer services department at the address indicated.



12. Charger indicator

Indicator status		Explanations and actions
Red LED	Green LED	
Off	Flashing	<p>Ready for use The charger is connected to the mains and is ready for use; there is no battery pack in the charger</p>
On	Off	<p>Charging The charger is charging the battery pack in quick charge mode. The charging times are shown directly on the charger. Important! The actual charging times may vary slightly from the stated charging times depending on the existing battery charge.</p>
Off	On	<p>The battery is charged and ready for use. (READY TO GO) The unit then changes over to gentle charging mode until the battery is fully charged. To do this, leave the rechargeable battery on the charger for approx. 15 minutes longer. Action: Take the battery pack out of the charger. Disconnect the charger from the mains supply.</p>
Flashing	Off	<p>Adapted charging The charger is in gentle charging mode. For safety reasons the charging is performed less quickly and takes more time. The reasons can be: - The rechargeable battery has not been used for a very long time. - The battery temperature is outside the ideal range. Action: Wait for the charging to be completed; you can still continue to charge the battery pack.</p>
Flashing	Flashing	<p>Fault Charging is no longer possible. The battery pack is defective. Action: Never charge a defective battery pack. Take the battery pack out of the charger.</p>
On	On	<p>Temperature fault The battery pack is too hot (e.g. due to direct sunshine) or too cold (below 0° C). Action: Remove the battery pack and keep it at room temperature (approx. 20° C) for one day .</p>

Disposal

Power tools, rechargeable batteries, accessories and packaging should be sorted for environmental-friendly recycling.

Do not dispose of power tools and batteries/rechargeable batteries into household waste!

Only for EU countries:

According to the Directive 2012/19/EU on waste electrical and electronic equipment and its transposition into national law, power tools that are no longer usable, and, according to the Directive 2006/66/EC, defective or drained batteries must be collected separately and disposed of in an environmentally correct manner.

If disposed incorrectly, waste electrical and electronic equipment may have harmful effects on the environment and human health, due to the potential presence of hazardous substances.

Only for United Kingdom:

According to The Waste Electrical and Electronic Equipment Regulations 2013 (SI 2013/3113) (as amended) and the Waste Batteries and Accumulators Regulations 2009 (SI 2009/890) (as amended), products that are no longer usable must be collected separately and disposed of in an environmentally friendly manner.

The reprinting or reproduction by any other means, in whole or in part, of documentation and papers accompanying products is permitted only with the express consent of the Einhell Germany AG.

Subject to technical changes

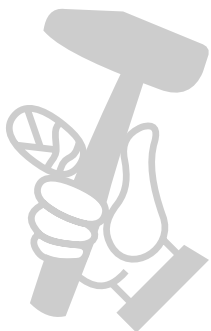

Service information

We have competent service partners in all countries named on the guarantee certificate whose contact details can also be found on the guarantee certificate. These partners will help you with all service requests such as repairs, spare and wearing part orders or the purchase of consumables.

Please note that the following parts of this product are subject to normal or natural wear and that the following parts are therefore also required for use as consumables.

Category	Example
Wear parts*	Blade guide, Battery
Consumables*	Blade
Missing parts	

* Not necessarily included in the scope of delivery!

In the event of defects or faults, please register the problem on the internet at www.Einhell-Service.com. Please ensure that you provide a precise description of the problem and answer the following questions in all cases:

- Did the equipment work at all or was it defective from the beginning?
- Did you notice anything (symptom or defect) prior to the failure?
- What malfunction does the equipment have in your opinion (main symptom)? Describe this malfunction.



Warranty certificate

Dear Customer,

All of our products undergo strict quality checks to ensure that they reach you in perfect condition. In the unlikely event that this equipment develops a fault, please contact our service department at the address shown on this guarantee card. You can also contact us by telephone using the service number shown. Please note the following terms under which guarantee claims can be made:

1. These guarantee terms apply solely to consumers, i.e. natural persons, who do not want to use this product in connection with either their commercial or other self-employed activities. These guarantee terms regulate additional guarantee services which the undermentioned manufacturer promises to buyers of its new products in addition to their statutory rights of guarantee. Your statutory rights of guarantee are not affected by this guarantee. Our guarantee is free of charge to you.
2. The guarantee services cover only defects due to material or manufacturing faults on the new product which you have bought in the European Union from the undermentioned manufacturer and are limited to either the rectification of said defects or the replacement of the product, whichever we prefer. Please note that only equipment under the brand name "Professional" has been designed for use in commercial, trade or professional applications. For all other products the guarantee is invalidated if the equipment is used within the guarantee period in commercial, trade or industrial applications or for other equivalent activities.
3. Our guarantee does not cover:
 - Damage to the equipment caused by failure to comply with the installation/assembly instructions or by unprofessional installation; damage caused by failure to comply with the operating instructions (e.g. connection to the wrong mains voltage or current type); damage caused by failure to comply with the maintenance and safety regulations; damage caused by exposing the equipment to abnormal environmental conditions; damage resulting from poor care and maintenance.
 - Damage to the equipment caused by misuse or incorrect applications (e.g. overloading the equipment or using non-approved attachments or accessories); damage caused by foreign bodies (e.g. sand, stones, dust, ...) getting inside the equipment. Damage in transit; damage caused by force or external influences (e.g. by dropping the equipment).
 - Damage to the equipment or parts of the equipment which is owed to use-related, normal or otherwise natural wear. For example, batteries and battery packs are manufactured with a cycle limit for design-related reasons. Wear is negatively influenced in particular by load demands and charging speeds as well as exposure to heat, cold, vibration and impact.
4. The guarantee is valid for a period of 2 years starting from the purchase date of the equipment. Guarantee claims must be submitted before the end of the guarantee period and within two weeks of the defect being noticed. No guarantee claims will be accepted after the end of the guarantee period. The original guarantee period remains applicable to the equipment even if repairs are carried out or parts are replaced. In such cases, the work performed or parts fitted will not result in an extension of the guarantee period, and no new guarantee will become active for the work performed or for any replacement parts fitted. This also applies if on-site service is used.
5. To assert your guarantee claim, register the defective equipment at: www.Einhell-Service.com. You will need to provide proof of purchase of the new item of equipment. Equipment returned without such proof or without a rating plate are excluded from the guarantee services because of the lack of traceability. If the defect is covered by our guarantee, then either the item in question will be repaired immediately and returned to you or we will send you a new replacement.
6. If you have taken the equipment with you to a different EU country than where you bought it, we will arrange for a local service partner to provide the guarantee services. If you take the equipment outside the EU, the guarantee will not apply.

Of course, we are also happy to offer a chargeable repair service for any defects which are not covered or no longer covered by the scope of this guarantee. To take advantage of this service, please send the equipment to our service address. We draw attention to the restrictions of this guarantee concerning wear parts, consumables and missing parts as presented in the service information included in this operating manual.

Warrantor/ Service:

Einhell UK Ltd, Unit 10, 1st Floor, Champion's Business Park, Arrove Brook Road, Upton, Wirral, CH49 0UQ