

D	Originalbetriebsanleitung Stationäre Hobelmaschine	E	Manual de instrucciones original Cepilladora estacionaria
GB	Original operating instructions Stationary planer	FIN	Alkuperäiskäyttöohje Oikotasohöylä
F	Instructions d'origine Raboteuse stationnaire	RUS	Оригинальное руководство по эксплуатации Стационарный строгальный станок
I	Istruzioni per l'uso originali Pialla a filo e spessore	SLO	Originalna navodila za uporabo Stacionarni stroj za skobljanje
DK/ N	Original betjeningsvejledning Stationær høvlemaskine	H	Eredeti használati utasítás Stacioneri gyalugép
S	Original-bruksanvisning Stationär hyvel	GR	Πρωτότυπες Οδηγίες χρήσης Σταθερή ηλεκτρική πλάνη
CZ	Originální návod k obsluze Stacionární hoblovka		
SK	Originálny návod na obsluhu Stacionárna hobľovačka		
NL	Originele handleiding Stationaire schaafmachine		

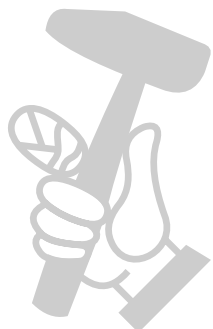

Art.-Nr.: 44.199.55

I.-Nr.: 21021

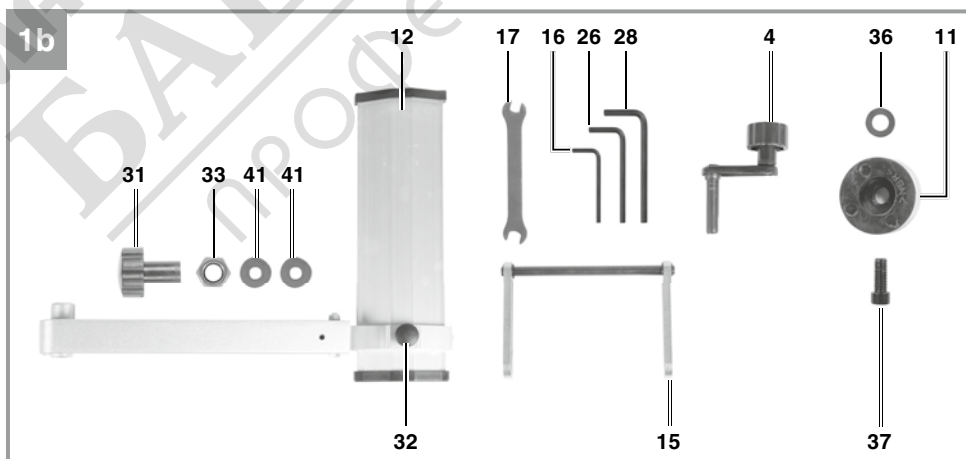
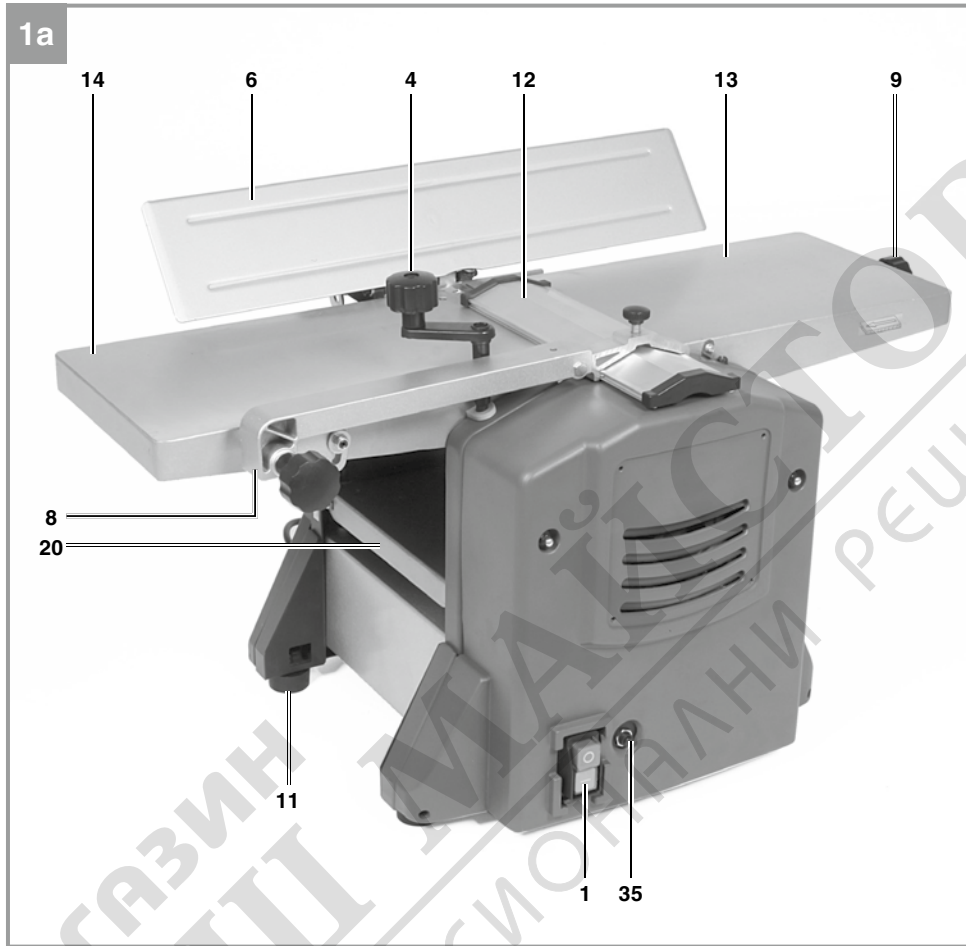

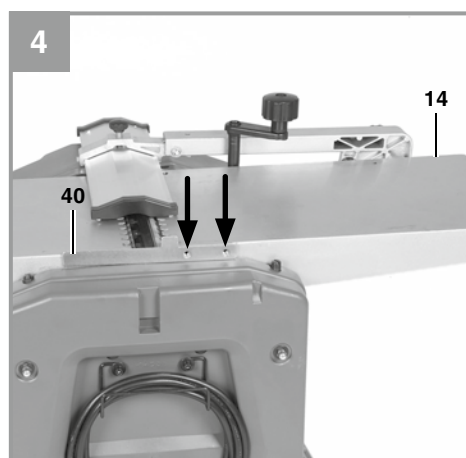
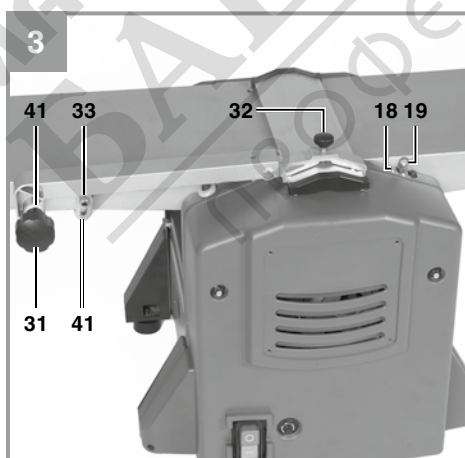
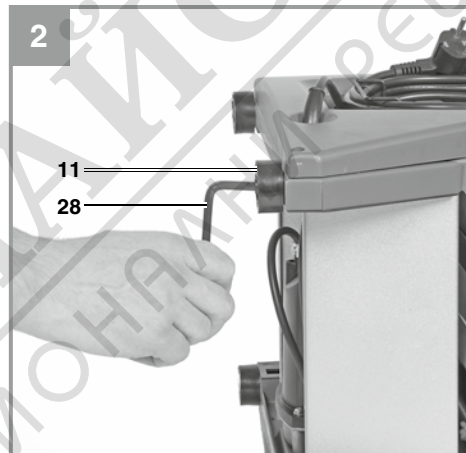
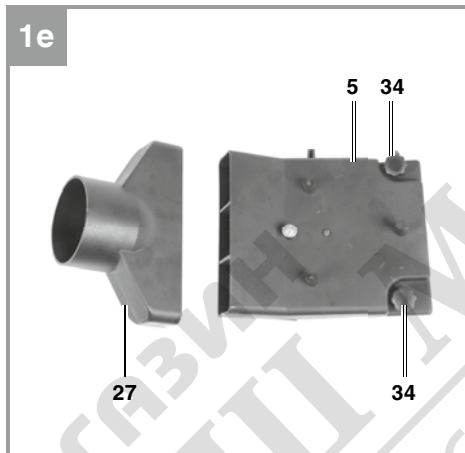
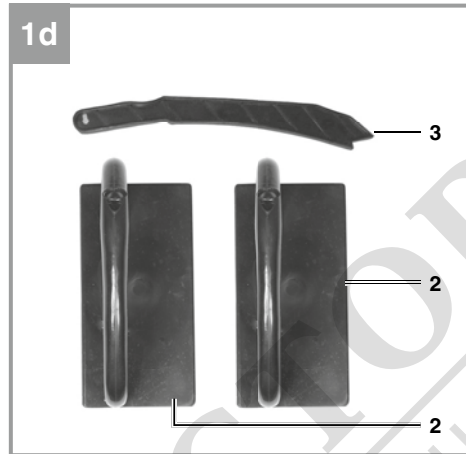
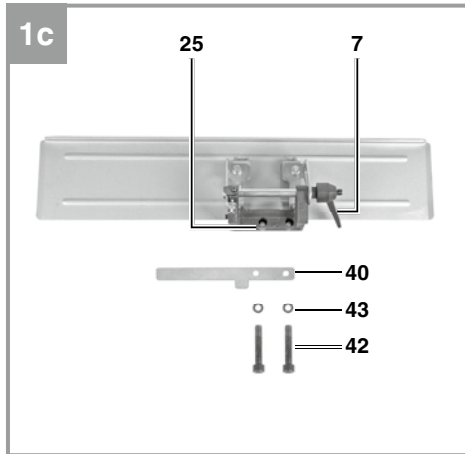

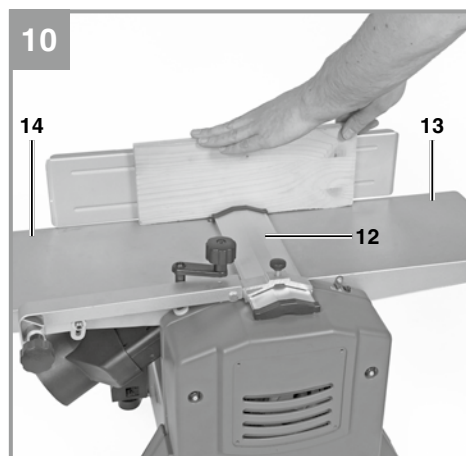
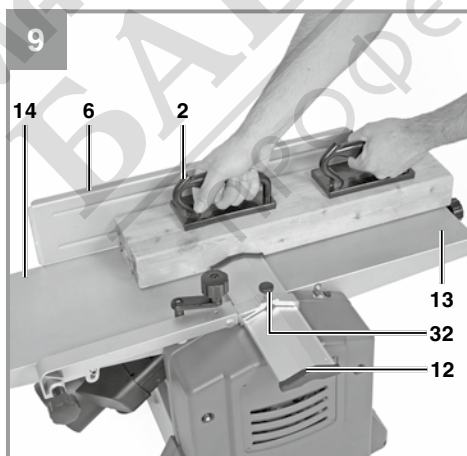
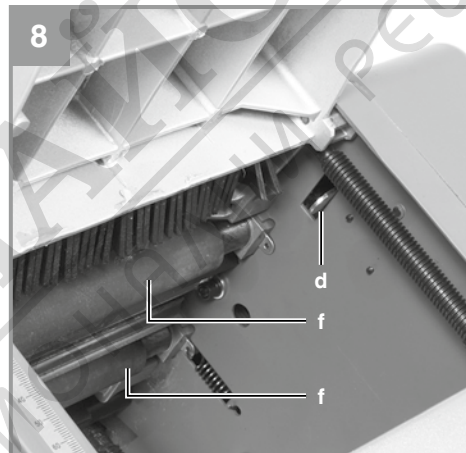
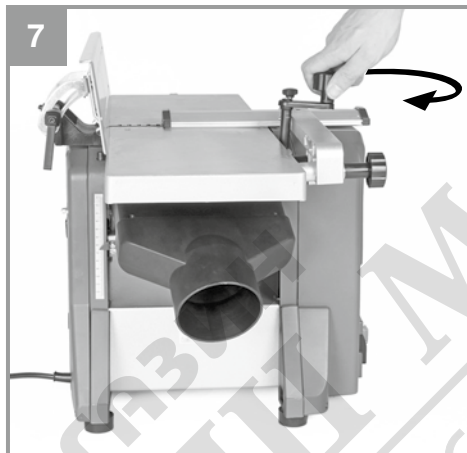
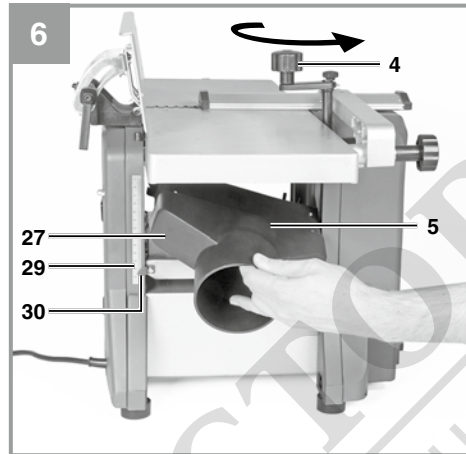
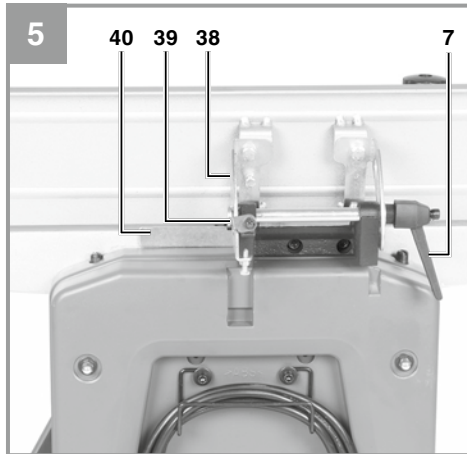

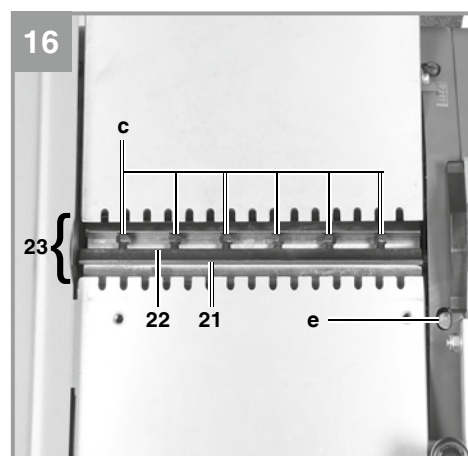
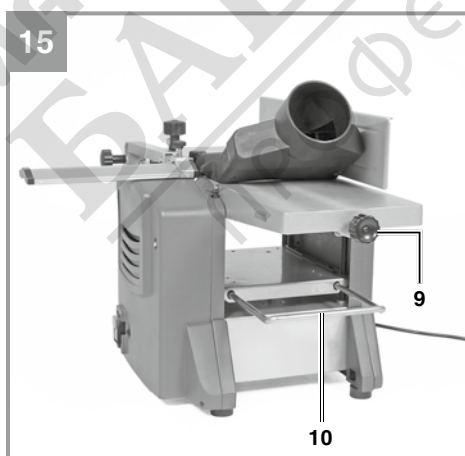
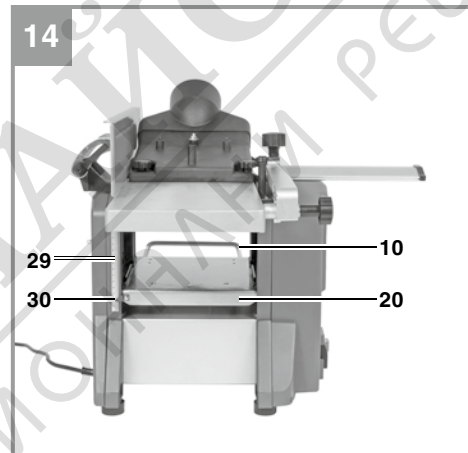
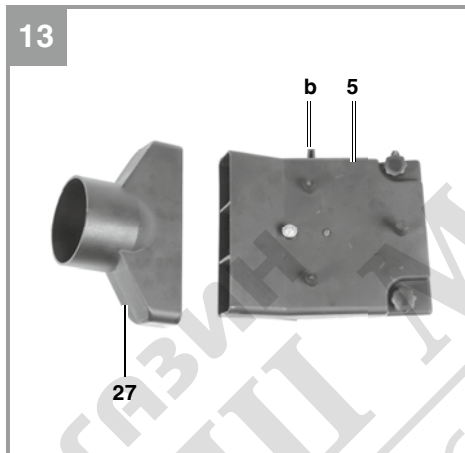
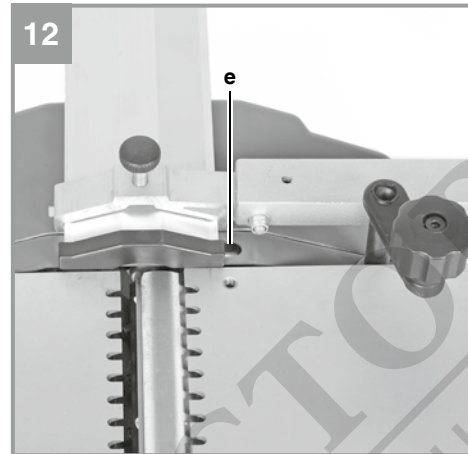
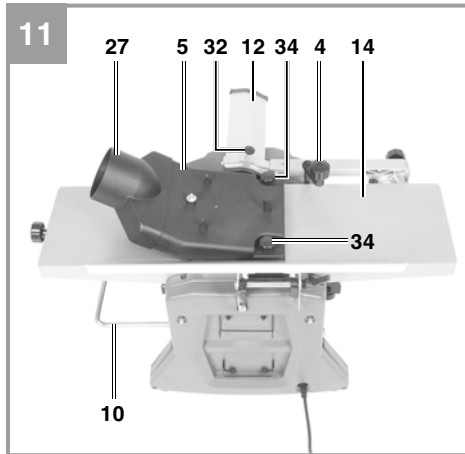

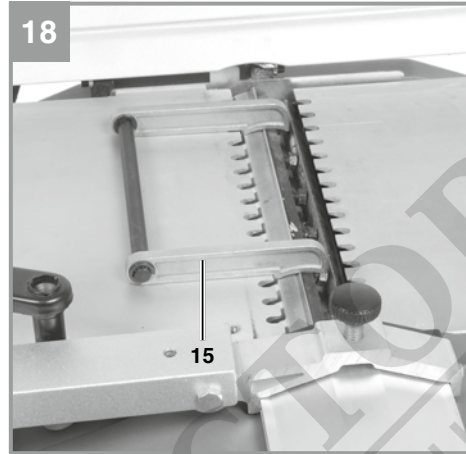
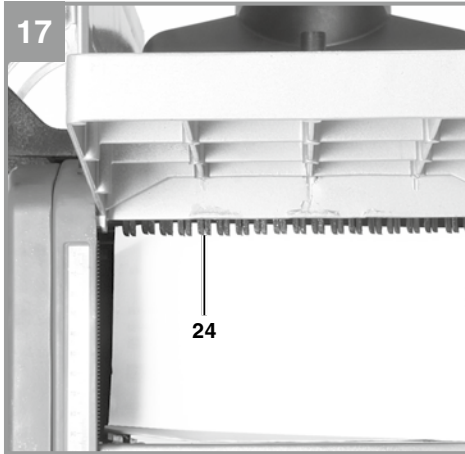

МАГАЗИН
БАШ МАЙСТОР
ПРОФЕСИОНАЛНИ РЕШЕНИЯ

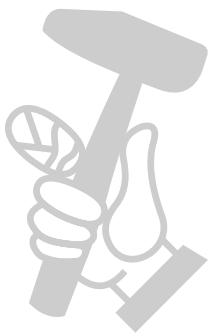



Danger! - Read the operating instructions to reduce the risk of injury



Caution! Wear ear-muffs. The impact of noise can cause damage to hearing.



Caution! Wear a breathing mask. Dust which is injurious to health can be generated when working on wood and other materials. Never use the device to work on any materials containing asbestos!



Caution! Wear safety goggles. Sparks generated during working or splinters, chips and dust emitted by the device can cause loss of sight.



OFF

ON

Overload switch



Caution! Risk of injury! Never reach into the planing knife during operation.

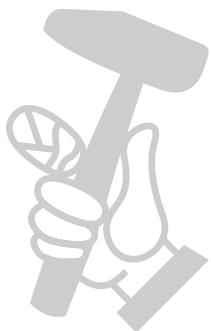

Danger!

When using the equipment, a few safety precautions must be observed to avoid injuries and damage. Please read the complete operating instructions and safety regulations with due care. Keep this manual in a safe place, so that the information is available at all times. If you give the equipment to any other person, hand over these operating instructions and safety regulations as well. We cannot accept any liability for damage or accidents which arise due to a failure to follow these instructions and the safety instructions.

1. Safety regulations

The corresponding safety information can be found in the enclosed booklet.

Danger!**Read all safety regulations and instructions.**

Any errors made in following the safety regulations and instructions may result in an electric shock, fire and/or serious injury.

Keep all safety regulations and instructions in a safe place for future use.

This appliance is not intended for use by persons (including children) with reduced physical, sensory or mental capabilities, or lack of experience and knowledge, unless they have been given supervision or instruction concerning use of the appliance by a person responsible for their safety. Children should be supervised to ensure that they do not play with the appliance.

2. Layout and items supplied**2.1 Layout (Fig. 1,3,5,6,11)**

- 1 On/Off switch
- 2 Slide block
- 3 Push stick
- 4 Hand crank
- 5 Chip extractor
- 6 Parallel stop
- 7 Clamping lever
- 8 Mounting for planing knife cover
- 9 Setting knob for the chip depth
- 10 Workpiece support
- 11 Rubber foot
- 12 Planing knife cover
- 13 Feed table
- 14 Planing table
- 15 Blade adjustment block

- 16 Hexagon wrench - small
- 17 Open-ended spanner
- 18 Scale
- 19 Pointer
- 20 Thicknessing table
- 21 Blade
- 22 Latch
- 23 Knife block
- 24 Anti-kick claws
- 25 Mounting
- 26 Hexagon wrench - medium
- 27 Chip extractor adapter Ø 100 mm
- 28 Hexagon wrench - large
- 29 Scale
- 30 Pointer
- 31 Locking knob
- 32 Locking knob
- 33 Nut, self-locking
- 34 Securing screw for chip extractor
- 35 Overload switch
- 36 Washer
- 37 Hexagon screw, short
- 38 Scale
- 39 Pointer
- 40 Cover plate for knife
- 41 Washer
- 42 Hexagon screw, long
- 43 Washer

2.2 Items supplied

Please check that the article is complete as specified in the scope of delivery. If parts are missing, please contact our service center or the sales outlet where you made your purchase at the latest within 5 working days after purchasing the product and upon presentation of a valid bill of purchase. Also, refer to the warranty table in the service information at the end of the operating instructions.

- Open the packaging and take out the equipment with care.
- Remove the packaging material and any packaging and/or transportation braces (if available).
- Check to see if all items are supplied.
- Inspect the equipment and accessories for transport damage.
- If possible, please keep the packaging until the end of the guarantee period.

Danger!

The equipment and packaging material are not toys. Do not let children play with plastic bags, foils or small parts. There is a danger of swallowing or suffocating!

- Plane
- Push stick
- Slide block (2x)
- Open-ended wrench
- Hexagon wrench, small
- Hexagon wrench, medium
- Hexagon wrench, large
- Rubber foot (4x)
- Assembly material
- Original operating instructions
- Safety information

3. Proper use

The surfacing and thicknessing plane is designed for the surfacing and thicknessing of all types of whole pieces of square, rectangular or chamfered converted timber.

The machine is to be used only for its prescribed purpose.

Even when the machine is used as prescribed it is still impossible to eliminate certain residual risk factors. There is a risk of the following injuries in connection with the required operation of the machine.

- Fingers or hands coming into contact with the knife block in areas which are out of view.
- Workpieces may kick back if the machine is used incorrectly.
- Damage to hearing and eye injuries plus injuries to fingers and hands if the required protective equipment is not used.
- Harmful emissions when used in enclosed areas without a suitable extractor system.

The equipment is to be used only for its prescribed purpose. Any other use is deemed to be a case of misuse. The user / operator and not the manufacturer will be liable for any damage or injuries of any kind caused as a result of this.

Please note that our equipment has not been designed for use in commercial, trade or industrial applications. Our warranty will be voided if the machine is used in commercial, trade or industrial businesses or for equivalent purposes.

4. Technical data

AC motor:.....	220-240 V ~ 50 Hz
Power P:	1500 W
Protection type:	IPX0
Max. workpiece width:	204 mm
Max. workpiece height at thickness opening:	120 mm
Surfacing plane table:	357 x 210 mm
Thicknessing table:	270 x 210 mm
Thicknessing feeding speed:	6 m/min
Idle speed of motor n0:	9000 rpm
Idle speed of planing knives:	9000 rpm
Max. planing cross-cutting depth:	3 mm
Max. thicknessing cross-cutting depth:	2 mm
Max. angle of the parallel stop:	45°
Sawdust extractor:	Ø 100 mm
Weight:.....	approx. 26.5 kg

Danger!

Sound and vibration

Sound and vibration values were measured in accordance with EN 61029.

L _{PA} sound pressure level	92,9 dB(A)
K _{PA} uncertainty	3 dB(A)
L _{WA} sound power level	105,9 dB(A)
K _{WA} uncertainty	3 dB(A)

Wear ear-muffs.

The impact of noise can cause damage to hearing.

Warning!

The specified vibration value was established in accordance with a standardized testing method. It may change according to how the electric equipment is used and may exceed the specified value in exceptional circumstances.

The specified vibration value can be used to compare the equipment with other electric power tools.

The specified vibration value can be used for initial assessment of a harmful effect.

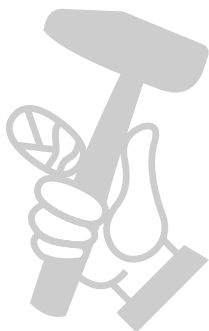

Keep the noise emissions and vibrations to a minimum.

- Only use appliances which are in perfect working order.
- Service and clean the appliance regularly.
- Adapt your working style to suit the appliance.
- Do not overload the appliance.
- Have the appliance serviced whenever necessary.
- Switch the appliance off when it is not in use.

Caution!

Residual risks

Even if you use this electric power tool in accordance with instructions, certain residual risks cannot be ruled out. The following hazards may arise in connection with the equipment's construction and layout:

1. Lung damage if no suitable protective dust mask is used.
2. Damage to hearing if no suitable ear protection is used.

5. Before starting the equipment

Before you connect the equipment to the mains supply make sure that the data on the rating plate are identical to the mains data.

- Warning! Pull out the power plug before performing any maintenance, cleaning and adjusting work.
- Check at regular intervals that the knife (21) and latch (22) are firmly attached in the knife block (23). (Fig. 16)
- The knives (21) must not project more than a maximum of 1.1 mm out of the knife block (23).
- Never remove the safety covers on the machine except for servicing and repair work.
- The safety covers must be intact at all times. Each time you use the machine, first fasten and secure the safety covers at the points provided.
- Connect a dust extractor to the sawdust extractor (5) if you use the machine in an enclosed area.
- Check the anti-kick claws (24) to ensure that they are in perfect working order (Fig. 17). The claws must be able to move easily so that they are freely suspended pointing downwards.
- Always wear eye protection.

- Never cut concavities, tenons or shapes.
- Unpack the surfacing and thickening plane and examine it for any transit damage.
- The machine has to be set up and aligned where it can stand securely.
- All covers and safety devices have to be properly fitted before the machine is switched on.
- It must be possible for the planing knife to run freely.
- When working with wood that has been processed before, watch out for foreign bodies such as nails or screws, etc.
- Before you press the ON/OFF switch (1), make sure that the planing knife is fitted correctly and that the machine's moving parts run smoothly.
- Before you connect the equipment to the mains supply make sure that the data on the rating plate are identical to the mains data.
- Inspect the feed/discharge rollers (f) visually check that they run uniformly for thickening. (see Fig. 8).

6. Assembly

6.1 Rubber feet (Figure 1-2)

Secure the four rubber feet (11) to the bottom side of the equipment using the Hexagon screws (37) and washers (36) supplied.

6.2 Planing knife cover (Figure 1-3)

- Place the mounting (8) for the planing knife cover on the left-hand side of the planing table (14).
- Secure the planing knife cover (12) with the supplied washer (41), the locking knob (31) and the nut (33).

6.3 Parallel stop (Figure 4/5)

- Place the mounting (25) and the cover plate (40) on the feed table.
- Make sure that the holes in the mounting and the cover plate line up with the threaded holes in the feed table.
- Screw the mounting and the cover plate to the feed table (13) with the help of the supplied Hexagon screws (42) and washers (13).

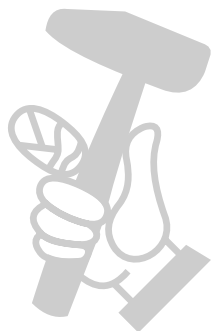

7. Operation

Important: The surfacing and thickening plane has been specially designed for planing solid wood. High alloy knives (21) are used for this purpose. The contact surface of the workpiece must be flat for thickening. If you want to work on large or heavy workpieces, the machine must be secured in place (e.g. using the thread in the machine base).

- The ON/OFF switch (1) is on the left-hand side of the machine. Press the green key "I" to switch on the machine. Press the red key "O" to switch off the machine.
- The motor of this equipment is protected against overload by an overload switch (35). If the rated current is exceeded, the overload switch will shut down the equipment. After a short cooling down period, the equipment can be switched on again by pressing the overload switch.
- To work on long workpieces, use roller tables or a similar supporting arrangement. Such optional units are available from your local DIY stores. They must be placed at the entry and exit ends of the plane. Their height must be adjusted such that the workpiece is horizontal when it is fed into and out of the machine.

7.1 Surfacing

Warning! Pull out the power plug before performing any maintenance, cleaning and adjusting work.

7.1.1 Adjustment (Fig. 1/3/5)

- Turn the adjustment knob for cutting depth (11) to set the height of the feed table (13). The set cutting depth can be read off the scale (18).
- Loosen the parallel stop (6) with the clamp lever (7). Set the required angle. The set angle can be read off the scale (38). Secure the parallel stop (6) with the clamp lever (7) again after making the setting.

7.1.2 Fitting the chip extractor (Figure 6-8/13)

- Fit the hand crank (4) to the post on the planing table (14). Turn the hand crank (4) counter-clockwise to move the thickening table (20) to its lowest position.
- Place the chip extractor (5) on the thickening table (20).
- Turn the crank handle (4) clockwise until the

chip extractor (5) is firmly secure and the recess (b) is on the safety switch (d).

- Attach the extraction system adapter Ø 100 mm (27) to the connection for a sawdust extractor (5).
- Connect the plane to a chip extraction system (not supplied).

7.1.3 Surfacing mode (Figure 9/10)

- Undo the locking knob (32) and move the planing knife cover (12) as far as necessary to accommodate the width of the workpiece. Re-tighten the locking knob (32).
- Connect the mains plug to the mains lead. Press the green "I" button to start the planer.
- Place the workpiece you wish to plane on the feed table (13). Hold the slide blocks (2) with both hands and slide the workpiece forwards towards the planing table (14) over the knives (21).
- When you have finished work, switch off the machine. Do this by pressing the red "O" button. Then disconnect the machine from the mains supply.
- Return the planing knife cover (12) to its original position.

7.2 Thickening

Warning! Pull out the power plug before performing any maintenance, cleaning and adjusting work.

7.2.1 Adjustment (Fig. 13)

Place the hand crank (4) on the post on the planing table (14) and turn it to adjust the thickening table (20) to the required height. The set angle can be read off the scale (29).

7.2.2 Fitting the chip extractor (Figure 11-15)

- Undo the locking knob (32) and pull the planing knife cover (12) forwards as far as possible.
- Place the chip extractor (5) on the planing table (14). Ensure that the stop pins and the securing screw (34) are in the appropriate holes and are engaged in the internal threads on the planing table (14) and that the recess (b) is on the safety switch (e).
- Turn the securing screw (34) until the chip extractor (5) is secure.
- Attach the extraction system adapter Ø 100 mm (27) to the connection for a sawdust extractor (5).

- Connect the plane to a chip extraction system (not supplied).

7.2.3 Thicknessing mode (Fig. 11/14)

- Connect the mains plug to the mains lead. Press the green "I" button to start the planer.
- Place a workpiece on the thicknessing table (20). Guide the workpiece towards the feed table (13).
- When you have finished work, switch off the machine. Do this by pressing the red "0" button. Then disconnect the machine from the mains supply.
- Use the pull-out workpiece support for long workpieces (10).

7.3 Changing the knives (Figure 16)

- **Warning!** Always pull the mains plug before changing the knives.
- Set the feed table to the maximum planing depth. (see 7.1.1)
- Remove the parallel stop following the instructions in 6.3 in reverse.
- Pull the planing knife cover (12) forwards as far as possible so that the entire knife block (23) is exposed.
- Undo the clamp screws (c) by turning them clockwise using the open-ended spanner (17) supplied. Turn the knife block (23) so that the latch (22) can be pulled out with the knife (21).
- Clean all the relevant parts and the knife slots in the knife block (23).
- Fit the latch (22) with the new knife (21) and align them with the side of the knife block.
- Place the blade adjustment block (15), as shown in Figure 18, on the knife block. Make sure that the knife (21) touches both sides of the blade adjustment block (15). Make sure that the knife reaches the same working height as the planing table.
- Tighten the clamp screws (c) using the open-ended spanner (17) supplied.
- Return the planing knife cover (12) to its original position so that the knife (21) is covered.

Warning!

Only use knives which are recommended by the manufacturer for this equipment. If you use other knives there is a risk of injuries due to lack of control. Avoid over-tightening and the possibility of the thread becoming detached. If the latch (22) or the screws have worn out threads they must be immediately replaced.

8. Troubleshooting

- 1. The machine cannot be switched on:**
 - No mains power. Check the power supply.
 - Carbon brushes worn. Have the carbon brushes replaced by an electrician.
 - Safety switches (d/e) not activated.
- 2. The machine cuts out when idling:**
 - Power failure (check fuses). Have the fuse replaced by an electrician.
- 3. The machine cuts out when planing:**
 - Blunt knife or feed speed too high. Replace the knife or reduce the feed speed.
- 4. Loss of speed when planing:**
 - Cutting depth too deep. Reduce cutting depth.
 - Feed speed too high. Reduce feed speed.
 - Blunt knife. Replace knife.
- 5. Poor surface quality on the planed workpiece:**
 - Blunt knife. Replace knife.
 - Uneven feed. Feed the workpiece at constant pressure and reduced feed speed.
 - Dust extraction system (not supplied) not connected. Connect dust extraction system.
- 6. Chip discharge for surfacing or thicknessing blocked:**
 - Dust extraction system (not supplied) not connected. Connect dust extraction system.
 - Wood too wet.
- 7. Uneven feed speed for thicknessing:**
 - Rubber belt too loose. Check rubber belt and replace if necessary.
 - Thicknessing table (20) soiled. Clean the thicknessing table (20) and treat with a lubricant if necessary.

9. Replacing the power cable

Danger!

If the power cable for this equipment is damaged, it must be replaced by the manufacturer or its after-sales service or similarly trained personnel to avoid danger.



10. Cleaning, maintenance and ordering of spare parts

Danger!

Pull out the power plug before performing any maintenance, cleaning and adjusting work

10.1 Cleaning

- Keep all safety devices, air vents and the motor housing free of dirt and dust as far as possible. Wipe the equipment with a clean cloth or blow it with compressed air at low pressure.
- We recommend that you clean the device immediately each time you have finished using it.
- Clean the equipment regularly with a moist cloth and some soft soap. Do not use cleaning agents or solvents; these could attack the plastic parts of the equipment. Ensure that no water can seep into the device. The ingress of water into an electric tool increases the risk of an electric shock.

10.2 Maintenance (Figure 1/15)

Important: Pull the mains plug before starting and maintenance work.

10.2.1 Machine

Lubricate the following parts periodically after around 10 hours of service:

- Bearings for the feed/discharge rollers (f) and anti-kick claws (24)
- Bearings on the belt roller and pulley
- Grub screws to adjust the height of the thickening table (20)

Use only dry lubricant.

The feed table (13), planing table (14), thickening table, feed/discharge rollers and anti-kick claws (24) must be kept free of resin at all times. Soiled feed/discharge rollers or anti-kick claws (24) must be cleaned without delay.

To prevent the motor overheating, the dust that accumulates in the ventilation openings must be removed at regular intervals.

Improve the smooth running of the tables by applying lubricant at regular intervals.

10.2.2 Cutting tool

Resin must be cleaned off the knife (21), latch (22) and knife block (23) at regular intervals.

Clean these components with an appropriate resin remover.

10.3 Ordering replacement parts:

Please quote the following data when ordering replacement parts:

- Type of machine
- Article number of the machine
- Identification number of the machine
- Replacement part number of the part required

For our latest prices and information please go to www.Einhell-Service.com

11. Disposal and recycling

The equipment is supplied in packaging to prevent it from being damaged in transit. The raw materials in this packaging can be reused or recycled. The equipment and its accessories are made of various types of material, such as metal and plastic. Never place defective equipment in your household refuse. The equipment should be taken to a suitable collection center for proper disposal. If you do not know the whereabouts of such a collection point, you should ask in your local council offices.

12. Storage

Store the equipment and accessories out of children's reach in a dark and dry place at above freezing temperature. The ideal storage temperature is between 5 and 30 °C. Store the electric tool in its original packaging.

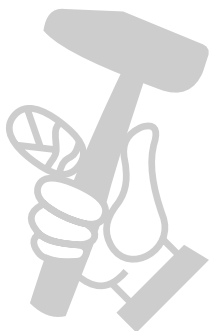



For EU countries only

Never place any electric power tools in your household refuse.

To comply with European Directive 2012/19/EC concerning old electric and electronic equipment and its implementation in national laws, old electric power tools have to be separated from other waste and disposed of in an environment-friendly fashion, e.g. by taking to a recycling depot.

Recycling alternative to the return request:

As an alternative to returning the equipment to the manufacturer, the owner of the electrical equipment must make sure that the equipment is properly disposed of if he no longer wants to keep the equipment. The old equipment can be returned to a suitable collection point that will dispose of the equipment in accordance with the national recycling and waste disposal regulations. This does not apply to any accessories or aids without electrical components supplied with the old equipment.

Please note that batteries and lamps (e.g. light bulbs) must be removed from the tool before it is disposed of.

The reprinting or reproduction by any other means, in whole or in part, of documentation and papers accompanying products is permitted only with the express consent of the Einhell Germany AG.

Subject to technical changes

- The product meets the requirements of EN 61000-3-11 and is subject to special connection conditions. This means that use of the product at any freely selectable connection point is not allowed.
- Given unfavorable conditions in the power supply the product can cause the voltage to fluctuate temporarily.
- The product is intended solely for use at connection points that
 - a) do not exceed a maximum permitted supply impedance, or
 - b) have a continuous current-carrying capacity of the mains of at least 100 A per phase.
- As the user, you are required to ensure, in consultation with your electric power company if necessary, that the connection point at which you wish to operate the product meets one of the two requirements, a) or b), named above.



Service information

We have competent service partners in all countries named on the guarantee certificate whose contact details can also be found on the guarantee certificate. These partners will help you with all service requests such as repairs, spare and wearing part orders or the purchase of consumables.

Please note that the following parts of this product are subject to normal or natural wear and that the following parts are therefore also required for use as consumables.

Category	Example
Wear parts*	V-belt / drive rollers
Consumables*	Planing knife
Missing parts	

* Not necessarily included in the scope of delivery!

In the effect of defects or faults, please register the problem on the internet at www.Einhell-Service.com. Please ensure that you provide a precise description of the problem and answer the following questions in all cases:

- Did the equipment work at all or was it defective from the beginning?
- Did you notice anything (symptom or defect) prior to the failure?
- What malfunction does the equipment have in your opinion (main symptom)? Describe this malfunction.

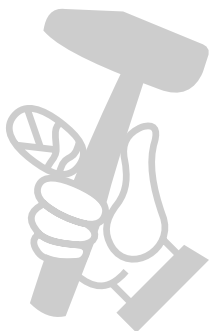

Warranty certificate

Dear Customer,

All of our products undergo strict quality checks to ensure that they reach you in perfect condition. In the unlikely event that this equipment develops a fault, please contact our service department at the address shown on this guarantee card. You can also contact us by telephone using the service number shown. Please note the following terms under which guarantee claims can be made:

1. These guarantee terms apply solely to consumers, i.e. natural persons, who do not want to use this product in connection with either their commercial or other self-employed activities. These guarantee terms regulate additional guarantee services which the undermentioned manufacturer promises to buyers of its new products in addition to their statutory rights of guarantee. Your statutory rights of guarantee are not affected by this guarantee. Our guarantee is free of charge to you.
2. The guarantee services cover only defects due to material or manufacturing faults on the new product which you have bought in the European Union from the undermentioned manufacturer and are limited to either the rectification of said defects or the replacement of the product, whichever we prefer. Please note that only equipment under the brand name "Professional" has been designed for use in commercial, trade or professional applications. For all other products the guarantee is invalidated if the equipment is used within the guarantee period in commercial, trade or industrial applications or for other equivalent activities.
3. Our guarantee does not cover:
 - Damage to the equipment caused by failure to comply with the installation/assembly instructions or by unprofessional installation; damage caused by failure to comply with the operating instructions (e.g. connection to the wrong mains voltage or current type); damage caused by failure to comply with the maintenance and safety regulations; damage caused by exposing the equipment to abnormal environmental conditions; damage resulting from poor care and maintenance.
 - Damage to the equipment caused by misuse or incorrect applications (e.g. overloading the equipment or using non-approved attachments or accessories); damage caused by foreign bodies (e.g. sand, stones, dust, ...) getting inside the equipment. Damage in transit; damage caused by force or external influences (e.g. by dropping the equipment).
 - Damage to the equipment or parts of the equipment which is owed to use-related, normal or otherwise natural wear. For example, batteries and battery packs are manufactured with a cycle limit for design-related reasons. Wear is negatively influenced in particular by load demands and charging speeds as well as exposure to heat, cold, vibration and impact.
4. The guarantee is valid for a period of 2 years starting from the purchase date of the equipment. Guarantee claims must be submitted before the end of the guarantee period and within two weeks of the defect being noticed. No guarantee claims will be accepted after the end of the guarantee period. The original guarantee period remains applicable to the equipment even if repairs are carried out or parts are replaced. In such cases, the work performed or parts fitted will not result in an extension of the guarantee period, and no new guarantee will become active for the work performed or for any replacement parts fitted. This also applies if on-site service is used.
5. To assert your guarantee claim, register the defective equipment at: www.Einhell-Service.com. You will need to provide proof of purchase of the new item of equipment. Equipment returned without such proof or without a rating plate are excluded from the guarantee services because of the lack of traceability. If the defect is covered by our guarantee, then either the item in question will be repaired immediately and returned to you or we will send you a new replacement.
6. If you have taken the equipment with you to a different EU country than where you bought it, we will arrange for a local service partner to provide the guarantee services. If you take the equipment outside the EU, the guarantee will not apply.

Of course, we are also happy to offer a chargeable repair service for any defects which are not covered or no longer covered by the scope of this guarantee. To take advantage of this service, please send the equipment to our service address. We draw attention to the restrictions of this guarantee concerning wear parts, consumables and missing parts as presented in the service information included in this operating manual.

Warrantor/ Service:

Einhell UK Ltd, Unit 10, 1st Floor, Champion's Business Park, Arroe Brook Road, Upton, Wirral, CH49 0UQ