

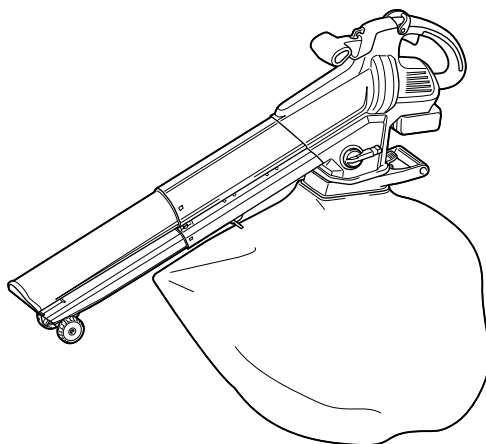

EN	Cordless Blower Vacuum	INSTRUCTION MANUAL	5
PL	Akumulatorowa Dmuchawa/ Odkurzacz do Liści	INSTRUKCJA OBSŁUGI	13
HU	Akkumulátoros vákuumfúvó	HASZNÁLATI KÉZIKÖNYV	22
SK	Akkumulátorové dúchadlo a vysávač	NÁVOD NA OBSLUHU	30
CS	Akkumulátorový podtlakový fukar	NÁVOD K OBSLUZE	38
UK	Акумуляторна повітродувка-всмоктувач	ІНСТРУКЦІЯ З ЕКСПЛУАТАЦІЇ	46
RO	Suflantă pentru aspirare cu acumulator	MANUAL DE INSTRUCȚIUNI	55
DE	Akku-Laubbläser/Sauger 18V	BETRIEBSANLEITUNG	64

DUB187

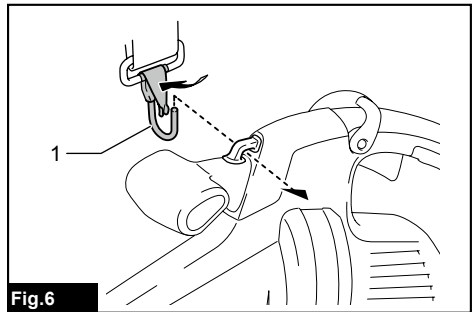

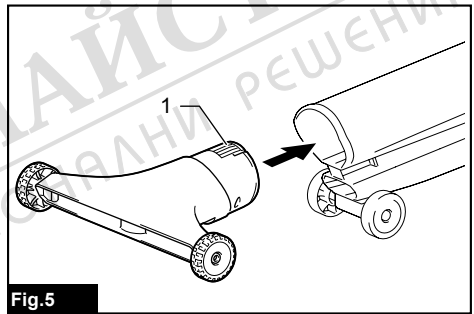
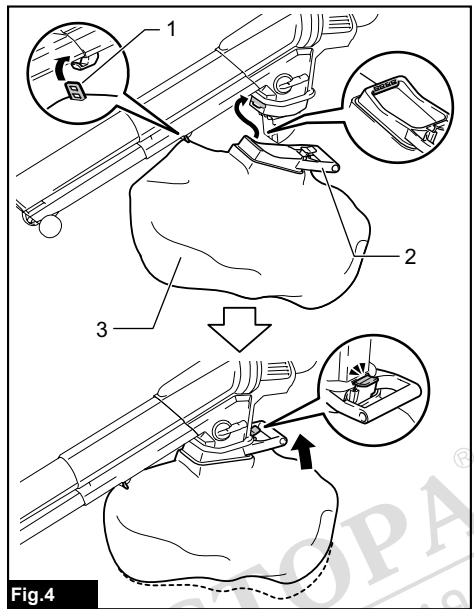
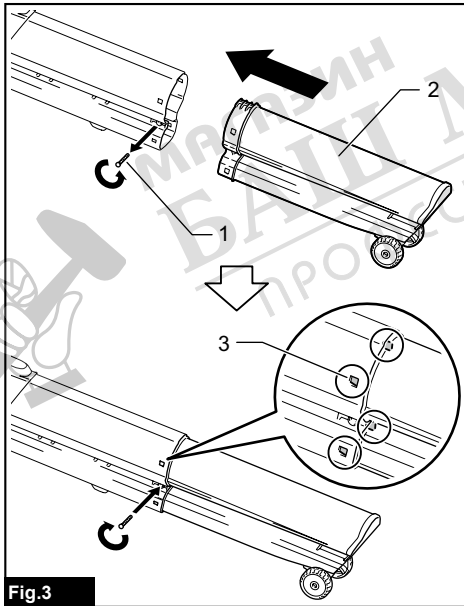
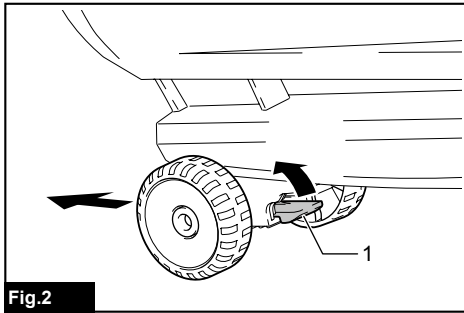
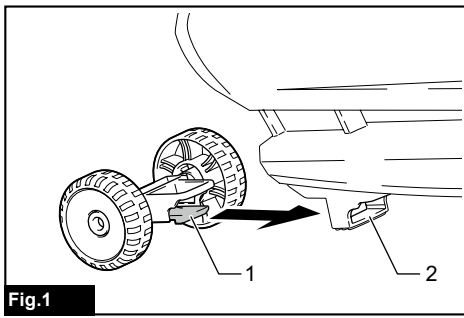

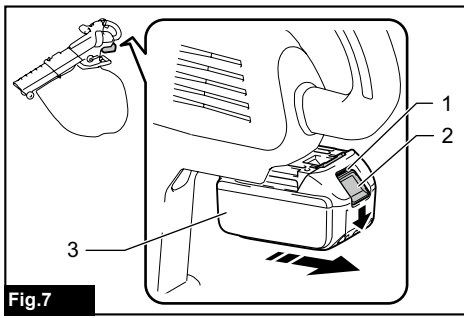

Fig.7

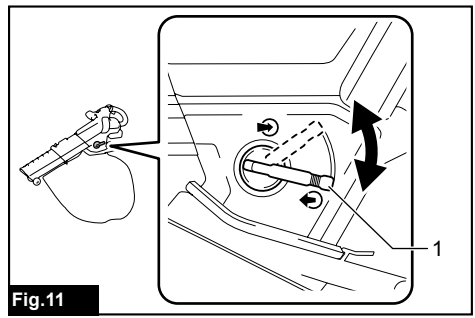

Fig.11

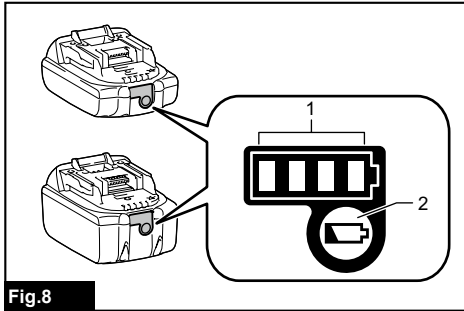

Fig.8



Fig.12

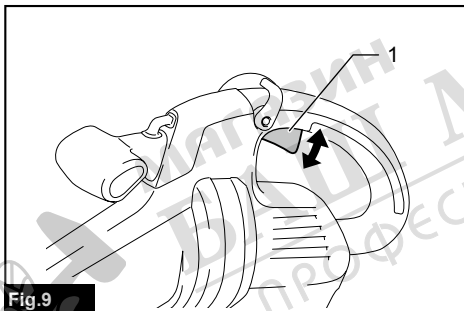

Fig.9

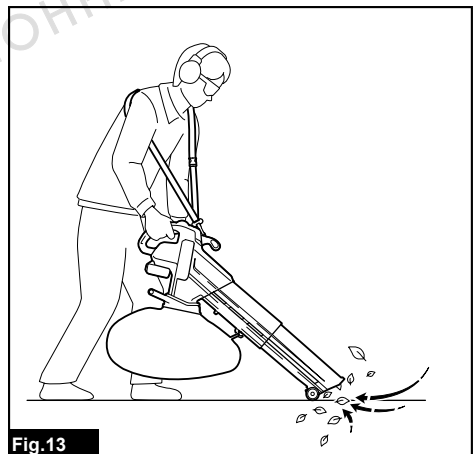

Fig.13

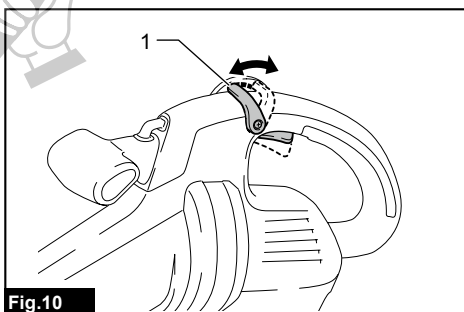

Fig.10

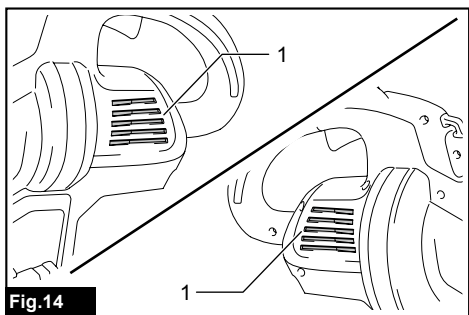

Fig.14



МАГАЗИН
БАШ МАЙСТОРА[®]
ПРОФЕСИОНАЛНИ РЕШЕНИЯ

SPECIFICATIONS

Model:		DUB187
Capacities (Blower)	Air volume	4.2 m ³ /min
	Air speed (average)	52 m/s
	Air speed (max.)	64 m/s
Capacities (Vacuum)	Air volume	6.1 m ³ /min
	Vacuum volume	25 liter
Overall length		1,168 mm
Rated voltage		18V d.c.
Net weight		3.7 - 4.0 kg

- Due to our continuing program of research and development, the specifications herein are subject to change without notice.
- Specifications may differ from country to country.
- The weight may differ depending on the attachment(s), including the battery cartridge. The lightest and heaviest combinations, according to EPTA-Procedure 01/2014, are shown in the table.

Applicable battery cartridge and charger

Battery cartridge	BL1815N / BL1820B / BL1830B / BL1840B / BL1850B / BL1860B
Charger	DC18RC / DC18RD / DC18RE / DC18SD / DC18SE / DC18SF / DC18SH / DC18WC

- Some of the battery cartridges and chargers listed above may not be available depending on your region of residence.

⚠WARNING: Only use the battery cartridges and chargers listed above. Use of any other battery cartridges and chargers may cause injury and/or fire.







Recommended cord connected power source

Portable power pack	PDC01
---------------------	-------

- The cord connected power source(s) listed above may not be available depending on your region of residence.
- Before using the cord connected power source, read instruction and cautionary markings on them.

Symbols

The followings show the symbols which may be used for the equipment. Be sure that you understand their meaning before use.

	Take particular care and attention.
	Read instruction manual.
	Keep hands away from rotating parts.
	Long hair may cause entanglement accident.
	Keep bystanders away.
	Wear eye and ear protection.



Do not expose to moisture.



Only for EU countries
 Due to the presence of hazardous components in the equipment, waste electrical and electronic equipment, accumulators and batteries may have a negative impact on the environment and human health. Do not dispose of electrical and electronic appliances or batteries with household waste!
 In accordance with the European Directive on waste electrical and electronic equipment and on accumulators and batteries and waste accumulators and batteries, as well as their adaptation to national law, waste electrical equipment, batteries and accumulators should be stored separately and delivered to a separate collection point for municipal waste, operating in accordance with the regulations on environmental protection.
 This is indicated by the symbol of the crossed-out wheeled bin placed on the equipment.



Guaranteed sound power level according to EU Outdoor Noise Directive.

Intended use

The machine is intended for blowing and vacuuming. Never use the machine for other purposes. Failure to do so may cause injury.

Noise

The typical A-weighted noise level determined according to EN50636-2-100:2014:

Sound pressure level (L_{pA}): 81.8 dB (A)

Uncertainty (K): 3 dB (A)

Sound power level (L_{WA}): 94.32 dB (A)

Uncertainty (K): 0.94 dB(A)

NOTE: The declared noise emission value(s) has been measured in accordance with a standard test method and may be used for comparing one tool with another.

NOTE: The declared noise emission value(s) may also be used in a preliminary assessment of exposure.

⚠ WARNING: Wear ear protection.

⚠ WARNING: The noise emission during actual use of the power tool can differ from the declared value(s) depending on the ways in which the tool is used especially what kind of workpiece is processed.

⚠ WARNING: Be sure to identify safety measures to protect the operator that are based on an estimation of exposure in the actual conditions of use (taking account of all parts of the operating cycle such as the times when the tool is switched off and when it is running idle in addition to the trigger time).

Vibration

The vibration total value (tri-axial vector sum) determined according to EN50636-2-100:2014:

Work mode: operation without load (blowing)

Vibration emission (a_h): < 2.5 m/s²

Uncertainty (K): 1.5 m/s²

Work mode: operation without load (vacuuming)

Vibration emission (a_h): < 2.5 m/s²

Uncertainty (K): 1.5 m/s²

NOTE: The declared vibration total value(s) has been measured in accordance with a standard test method and may be used for comparing one tool with another.

NOTE: The declared vibration total value(s) may also be used in a preliminary assessment of exposure.

⚠ WARNING: The vibration emission during actual use of the power tool can differ from the declared value(s) depending on the ways in which the tool is used especially what kind of workpiece is processed.

⚠ WARNING: Be sure to identify safety measures to protect the operator that are based on an estimation of exposure in the actual conditions of use (taking account of all parts of the operating cycle such as the times when the tool is switched off and when it is running idle in addition to the trigger time).

EC Declaration of Conformity

For European countries only

The EC declaration of conformity is included as Annex A to this instruction manual.

SAFETY WARNINGS

Cordless Blower Vacuum Safety Instructions

⚠ WARNING: Read all safety warnings and all instructions. Failure to follow the warnings and instructions may result in electric shock, fire and/or serious injury.

Save all warnings and instructions for future reference.

Training

1. Read the instructions carefully. Be familiar with the controls and the correct use of the machine.
2. Never allow children, persons with reduced physical, sensory or mental capabilities or lack of experience and knowledge or people unfamiliar with these instructions to use the machine. Local regulations may restrict the age of the operator.
3. Never operate the machine while people, especially children, or pets are nearby.
4. Keep in mind that the operator or user is responsible for accidents or hazards occurring to other people or their property by failure to follow the instructions in this instruction manual.

Preparation

1. Always wear substantial footwear and long trousers while operating the machine.
2. Do not wear loose clothing or jewellery that can be drawn into the air inlet. Keep long hair away from the air inlets.
3. Always wear protective goggles to protect your eyes from injury when using power tools. The goggles must comply with ANSI Z87.1 in the USA, EN 166 in Europe, or AS/NZS 1336 in Australia/New Zealand. In Australia/New Zealand, it is legally required to wear a face shield to protect your face, too.

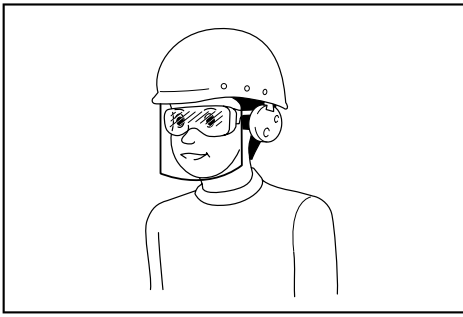

It is an employer's responsibility to enforce the use of appropriate safety protective equipments by the tool operators and by other persons in the immediate working area.

4. To prevent dust irritation the wearing of a face mask is recommended.
5. While operating the machine, always wear non-slip and protective footwear. Non-skid, closed-toed safety boots and shoes will reduce the risk of injury.
6. Use personal protective equipment. Always wear eye protection. Protective equipment such as a dust mask, non-skid safety shoes, hard hat or hearing protection used for appropriate conditions will reduce personal injuries.

Operation

1. Switch off the machine and remove the battery cartridge and make sure that all moving parts have come to a complete stop
 - whenever you leave the machine.
 - before clearing blockages.
 - before checking, cleaning or working on the machine.
 - if the machine starts to vibrate abnormally.
 - whenever you convert the machine from blower to vacuum, and vice versa.
 - after striking a foreign object to inspect the machine for damage.
2. Operate the machine only in daylight or in good artificial light.
3. Do not overreach and keep proper balance and footing at all times.
4. Always be sure of your footing on slopes.
5. Walk, never run.
6. Keep all cooling air inlets clear of debris.
7. When using the machine for blower operation, never blow debris in the direction of bystanders. When using the machine for vacuuming operation, be careful not to blow debris in the direction of bystanders with the exhausted wind from the dust bag.
8. Operate the machine in a recommended position and on a firm surface.
9. Do not operate the machine at high places.
10. Never point the nozzle at anyone in the vicinity when using the machine.
11. Never block suction inlet and/or blower outlet.
 - Be careful not to block suction inlet or blower outlet with dust or dirt when operating in dusty area.

- Do not use nozzles other than the nozzles provided by Makita.
 - Do not use the blower to inflate balls, rubber boat or the similar.
12. Do not operate the machine near open window, etc.
 13. Operating the machine only at reasonable hours is recommended - not early in the morning or late at night when people might be disturbed.
 14. Using rakes and brooms to loosen debris before blowing is recommended.
 15. If the machine strikes any foreign objects or should start making any unusual noise or vibration, immediately switch off the machine to stop it. Remove the battery cartridge from the machine and inspect the machine for damage before restarting and operating the machine. If the machine is damaged, ask Makita Authorized Service Centers for repair.
 16. Do not insert fingers or other objects into suction inlet or blower outlet.
 17. Prevent unintentional starting. Ensure the switch is in the off-position before inserting battery cartridge, picking up or carrying the machine. Carrying the machine with your finger on the switch or energizing the machine that has the switch on invites accidents.
 18. Never blow or vacuum dangerous materials, such as nails, fragments of glass, or blades.
 19. Do not operate the machine near flammable materials.
 20. Avoid operating the machine for a long time in low temperature environment.
 21. Never operate the machine with defective guards or shields, or without safety devices.

Maintenance and storage

1. Keep all nuts, bolts and screws tight to be sure the machine is in safe working condition.
2. If the parts are worn or damaged, replace them with parts provided by Makita.
3. Store the machine in a dry place out of the reach of children.
4. When you stop the machine for inspection, servicing, storage, or changing accessory, switch off the machine and make sure that all moving parts come to a complete stop, and remove the battery cartridge. Cool down the machine before making any work on the machine. Maintain the machine with care and keep it clean.

Failure to do so may cause accident or injury.
5. Always cool down the machine before storing.
6. Do not expose the machine to rain. Store the machine indoors.
7. When you lift the machine, be sure to bend your knees and be careful not to hurt your back.
8. Perform the maintenance regularly. It is recommended to perform the maintenance before each operation.

Battery tool use and care

1. Recharge only with the charger specified by the manufacturer. A charger that is suitable for one type of battery cartridge may create a risk of fire when used with another battery cartridge.

2. **Use power tools only with specifically designed battery cartridges.** Use of any other battery cartridges may create a risk of injury and fire.
3. **When battery cartridge is not in use, keep it away from other metal objects, like paper clips, coins, keys, nails, screws or other small metal objects, that can make a connection from one terminal to another.** Shorting the battery terminals together may cause burns or a fire.
4. **Under abusive conditions, liquid may be ejected from the battery; avoid contact. If contact accidentally occurs, flush with water. If liquid contacts eyes, additionally seek medical help.** Liquid ejected from the battery may cause irritation or burns.
5. **Do not use a battery cartridge or tool that is damaged or modified.** Damaged or modified battery cartridges may exhibit unpredictable behaviour resulting in fire, explosion or risk of injury.
6. **Do not expose a battery cartridge or tool to fire or excessive temperature.** Exposure to fire or temperature above 130 °C may cause explosion.
7. **Follow all charging instructions and do not charge the battery cartridge or tool outside the temperature range specified in the instructions.** Charging improperly or at temperatures outside the specified range may damage the battery and increase the risk of fire.

Electrical and battery safety

1. **Do not dispose of the battery cartridges in a fire.** The cell may explode. Check with local codes for possible special disposal instructions.
2. **Do not open or mutilate the battery cartridges.** Released electrolyte is corrosive and may cause damage to the eyes or skin. It may be toxic if swallowed.
3. **Do not charge battery cartridge in rain, or in wet locations.**
4. **Avoid dangerous environment. Don't use the machine in dump or wet locations or expose it to rain.** Water entering the machine will increase the risk of electric shock.

Service

1. **Have your power tool serviced by a qualified repair person using only identical replacement parts.** This will ensure that the safety of the power tool is maintained.
2. **Never service damaged battery cartridges.** Service of battery cartridges should only be performed by the manufacturer or authorized service providers.

SAVE THESE INSTRUCTIONS.

⚠WARNING: DO NOT let comfort or familiarity with product (gained from repeated use) replace strict adherence to safety rules for the subject product.

MISUSE or failure to follow the safety rules stated in this instruction manual may cause serious personal injury.

Important safety instructions for battery cartridge

1. **Before using battery cartridge, read all instructions and cautionary markings on (1) battery charger, (2) battery, and (3) product using battery.**
2. **Do not disassemble or tamper with the battery cartridge.** It may result in a fire, excessive heat, or explosion.
3. **If operating time has become excessively shorter, stop operating immediately.** It may result in a risk of overheating, possible burns and even an explosion.
4. **If electrolyte gets into your eyes, rinse them out with clear water and seek medical attention right away.** It may result in loss of your eyesight.
5. **Do not short the battery cartridge:**
 - (1) **Do not touch the terminals with any conductive material.**
 - (2) **Avoid storing battery cartridge in a container with other metal objects such as nails, coins, etc.**
 - (3) **Do not expose battery cartridge to water or rain.**

A battery short can cause a large current flow, overheating, possible burns and even a breakdown.

6. **Do not store and use the tool and battery cartridge in locations where the temperature may reach or exceed 50 °C (122 °F).**
7. **Do not incinerate the battery cartridge even if it is severely damaged or is completely worn out.** The battery cartridge can explode in a fire.
8. **Do not nail, cut, crush, throw, drop the battery cartridge, or hit against a hard object to the battery cartridge.** Such conduct may result in a fire, excessive heat, or explosion.
9. **Do not use a damaged battery.**
10. **The contained lithium-ion batteries are subject to the Dangerous Goods Legislation requirements.**

For commercial transports e.g. by third parties, forwarding agents, special requirement on packaging and labeling must be observed. For preparation of the item being shipped, consulting an expert for hazardous material is required. Please also observe possibly more detailed national regulations.

Tape or mask off open contacts and pack up the battery in such a manner that it cannot move around in the packaging.
11. **When disposing the battery cartridge, remove it from the tool and dispose of it in a safe place.** Follow your local regulations relating to disposal of battery.
12. **Use the battery cartridges only with the products specified by Makita.** Installing the battery cartridges to non-compliant products may result in a fire, excessive heat, explosion, or leak of electrolyte.
13. **If the tool is not used for a long period of time, the battery must be removed from the tool.**

14. **During and after use, the battery cartridge may take on heat which can cause burns or low temperature burns. Pay attention to the handling of hot battery cartridges.**
15. **Do not touch the terminal of the tool immediately after use as it may get hot enough to cause burns.**
16. **Do not allow chips, dust, or soil stuck into the terminals, holes, and grooves of the battery cartridge.** It may cause heating, catching fire, burst and malfunction of the tool or battery cartridge, resulting in burns or personal injury.
17. **Unless the tool supports the use near high-voltage electrical power lines, do not use the battery cartridge near high-voltage electrical power lines.** It may result in a malfunction or breakdown of the tool or battery cartridge.
18. **Keep the battery away from children.**

SAVE THESE INSTRUCTIONS.

CAUTION: Only use genuine Makita battery cartridges. Use of non-genuine Makita battery cartridges, or battery cartridges that have been altered, may result in the battery bursting causing fires, personal injury and damage. It will also void the Makita warranty for the Makita tool and charger.

Tips for maintaining maximum battery life

1. **Charge the battery cartridge before completely discharged. Always stop tool operation and charge the battery cartridge when you notice less tool power.**
2. **Never recharge a fully charged battery cartridge. Overcharging shortens the battery service life.**
3. **Charge the battery cartridge with room temperature at 10 °C - 40 °C (50 °F - 104 °F). Let a hot battery cartridge cool down before charging it.**
4. **When not using the battery cartridge, remove it from the tool or the charger.**
5. **Charge the battery cartridge if you do not use it for a long period (more than six months).**

ASSEMBLY

CAUTION: Always be sure that the machine is switched off and the battery cartridge is removed before carrying out any work on the machine.

Installing or removing the wheels

To install the wheels, insert the claw of the wheels into the slot of the nozzle as shown in the figure.

► **Fig.1:** 1. Claw 2. Slot

To remove the wheels, slide the claw upward slightly, and then remove the wheels.

► **Fig.2:** 1. Claw

Installing the nozzle

Loosen and remove the screw of the main unit. Align the protrusions on the nozzle with the grooves on the main unit, then insert the nozzle into the main unit until the protrusions snap into place. Tighten the screw securely to fix the nozzle.

► **Fig.3:** 1. Screw 2. Nozzle 3. Protrusion

Installing or removing the dust bag

Hook the claw of the dust bag to the hook of the main unit, then hook the front side of the handle of the dust bag to the main unit, and then pull up the rear side of the handle until handle snaps into place as shown in the figure.

► **Fig.4:** 1. Claw 2. Handle 3. Dust bag

To remove the dust bag, perform the installation procedure in reverse.

Installing or removing the wide nozzle

Optional accessory

Insert the wide nozzle with its protrusions facing up into the nozzle.

► **Fig.5:** 1. Protrusion

Attaching the shoulder strap

CAUTION: When you use the machine in combination of the backpack-type power supply such as portable power pack, do not use the shoulder harness included in the machine package, but use the hanging band recommended by Makita.

If you put on the shoulder harness included in the machine package and the shoulder harness of the backpack-type power supply at the same time, removing the machine or backpack-type power supply is difficult in case of an emergency, and it may cause an accident or injury. For the recommended hanging band, ask Makita Authorized Service Centers.

CAUTION: Be sure to attach the hooks of the shoulder strap to the machine securely. If the hooks are attached incompletely, they may come off and cause an injury.

CAUTION: Be sure to use the shoulder strap dedicated to this machine. Using other shoulder strap may cause an injury.

Attach the hook of the shoulder strap to the machine as shown in the figure.

► **Fig.6:** 1. Hook

FUNCTIONAL DESCRIPTION

CAUTION: Always be sure that the machine is switched off and the battery cartridge is removed before adjusting or checking function on the machine.

Installing or removing battery cartridge

CAUTION: Always switch off the machine before installing or removing of the battery cartridge.

CAUTION: Hold the machine and the battery cartridge firmly when installing or removing battery cartridge. Failure to hold the machine and the battery cartridge firmly may cause them to slip off your hands and result in damage to the machine and battery cartridge and a personal injury.

CAUTION: Always install the battery cartridge fully until the red indicator cannot be seen. If not, it may accidentally fall out of the machine, causing injury to you or someone around you.

CAUTION: Do not install the battery cartridge forcibly. If the cartridge does not slide in easily, it is not being inserted correctly.

► Fig.7: 1. Red indicator 2. Button 3. Battery cartridge

To remove the battery cartridge, slide it from the machine while sliding the button on the front of the cartridge.

To install the battery cartridge, align the tongue on the battery cartridge with the groove in the housing and slip it into place. Insert it all the way until it locks in place with a little click. If you can see the red indicator on the upper side of the button, it is not locked completely.

Indicating the remaining battery capacity

Only for battery cartridges with the indicator

► Fig.8: 1. Indicator lamps 2. Check button

Press the check button on the battery cartridge to indicate the remaining battery capacity. The indicator lamps light up for a few seconds.

Indicator lamps			Remaining capacity
Lighted	Off	Blinking	
■	□	▧	75% to 100%
■ ■ ■ ■			
■ ■ ■ □			
■ ■ □ □			
■ □ □ □			50% to 75%
■ □ □ □			25% to 50%
■ □ □ □			0% to 25%
▧ □ □ □			Charge the battery.
■ ■ □ □			The battery may have malfunctioned.
□ □ ■ ■			

NOTE: Depending on the conditions of use and the ambient temperature, the indication may differ slightly from the actual capacity.

NOTE: The first (far left) indicator lamp will blink when the battery protection system works.

Machine/battery protection system

The machine is equipped with a machine/battery protection system. This system automatically cuts off power to the motor to extend machine and battery life. The machine will automatically stop during operation if the machine or battery is placed under one of the following conditions:

Overload protection

When the machine or battery is operated in a manner that causes it to draw an abnormally high current, the machine automatically stops. In this situation, turn the machine off and stop the application that caused the machine to become overloaded. Then turn the machine on to restart.

Overheat protection

When the machine or battery is overheated, the machine stops automatically. In this case, let the machine and battery cool before turning the machine on again.

Overdischarge protection

When the battery capacity is not enough, the machine stops automatically. In this case, remove the battery from the machine and charge the battery.

Protections against other causes

Protection system is also designed for other causes that could damage the machine and allows the machine to stop automatically. Take all the following steps to clear the causes, when the machine has been brought to a temporary halt or stop in operation.

1. Turn the machine off, and then turn it on again to restart.
2. Charge the battery(ies) or replace it/them with recharged battery(ies).
3. Let the machine and battery(ies) cool down.

If no improvement can be found by restoring protection system, then contact your local Makita Service Center.

NOTICE: If the machine stops due to a cause not described above, refer to the section for troubleshooting.

Switch action

⚠ WARNING: Before installing the battery cartridge into the machine, always check to see that the switch trigger actuates properly and returns to the "OFF" position when released.

► Fig.9: 1. Switch trigger

To start the machine, simply pull the switch trigger. The speed is increased by increasing pressure on the switch trigger. Release the switch trigger to stop.

NOTE: If you install the battery cartridge while pulling the switch trigger, the machine does not start. To start the machine, first release the switch trigger and return the control lever fully, and then pull the switch trigger.

Cruise control function

The cruise control function allows the operator to maintain a constant speed without pulling the trigger. To increase the speed, turn the control lever forward. To decrease the speed, turn the control lever backward.

► Fig.10: 1. Control lever

Switching the operation

You can switch the blowing operation and vacuuming operation using the change lever. To use the machine for blowing operation, pull down the change lever fully. To use the machine for vacuuming operation, pull up the change lever fully.

► Fig.11: 1. Change lever

NOTICE: If you vacuum a large amount of dust such as sand, switching the change lever may become heavy due to the dust. In this case, turn off the machine and switch the change lever two or three times to clear away the dust.

OPERATION

⚠ CAUTION: When performing the blower operation or vacuuming operation, be sure to attach the dust bag to the machine.

⚠ CAUTION: Do not place the machine on the ground while it is switched on. Sand or dust may enter from suction inlet and cause a malfunction or personal injury.

Before operating the machine, adjust the length of the shoulder strap to a comfortable position for your work.

Blower operation

Hold the machine firmly and perform the blowing operation by moving it around slowly. When blowing around building, big stone or vehicle, direct the nozzle away from them. When performing an operation in a corner, start from the corner and then move to wide area.

► Fig.12

Vacuumping operation

⚠ CAUTION: Check the dust bag frequently for wear or deterioration.

⚠ CAUTION: Always switch off the machine before removing or attaching the dust bag.

⚠ CAUTION: Be sure to fasten the fastener of the dust bag before operating the machine.

⚠ CAUTION: Always switch off the machine before opening or fastening the fastener of the dust bag.

NOTICE: Do not allow wet materials, such as wet leaves, and foreign materials, such as large wood chips, metals, glass, pebbles, etc., to be sucked into the machine. Otherwise, a malfunction may occur.

NOTICE: Empty the dust bag before it becomes full. Otherwise, a malfunction may occur.

Hold the machine with one hand. While operating the machine, adjust the switch trigger so that the suction force is appropriate for the work location and conditions.

► Fig.13

MAINTENANCE

⚠ CAUTION: Always be sure that the machine is switched off and the battery cartridge is removed before attempting to perform inspection or maintenance.

To maintain product SAFETY and RELIABILITY, repairs, any other maintenance or adjustment should be performed by Makita Authorized or Factory Service Centers, always using Makita replacement parts.

Cleaning the machine

Clean the machine by wiping off dust with a dry cloth or one dipped in soapy water and wrung out.

NOTICE: Never use gasoline, benzine, thinner, alcohol or the like. Discoloration, deformation or cracks may result.

Remove dust or dirt from the suction inlets.

► Fig.14: 1. Suction inlet

TROUBLESHOOTING

Before asking for repairs, conduct your own inspection first. If you find a problem that is not explained in the manual, do not attempt to dismantle the machine. Instead, ask Makita Authorized Service Centers, always using Makita replacement parts for repairs.

State of abnormality	Probable cause (malfunction)	Remedy
Motor does not run.	Battery cartridge is not installed.	Install the battery cartridge.
	Battery problem (under voltage)	Recharge the battery. If recharging is not effective, replace battery.
	The drive system does not work correctly.	Ask your local authorized service center for repair.
Motor stops running after a little use.	Battery's charge level is low.	Recharge the battery. If recharging is not effective, replace battery.
	Overheating.	Stop using the machine to allow it to cool down.
The machine does not reach the maximum speed.	Battery is installed improperly.	Install the battery cartridge as described in this manual.
	Battery power is dropping.	Recharge the battery. If recharging is not effective, replace battery.
	The drive system does not work correctly.	Ask your local authorized service center for repair.
Abnormal vibration: ⇒ stop the machine immediately!	The drive system does not work correctly.	Ask your local authorized service center for repair.
Motor cannot stop: ⇒ Remove the battery immediately!	Electric or electronic malfunction.	Remove the battery and ask your local authorized service center for repair.

OPTIONAL ACCESSORIES

CAUTION: These accessories or attachments are recommended for use with your Makita product specified in this manual. The use of any other accessories or attachments might present a risk of injury to persons. Only use accessory or attachment for its stated purpose.

If you need any assistance for more details regarding these accessories, ask your local Makita Service Center.

- Wide nozzle
- Makita genuine battery and charger

NOTE: Some items in the list may be included in the product package as standard accessories. They may differ from country to country.