

(D)	Originalbetriebsanleitung - Druckluft-Exzentrerschleifer	7
(GB)	Original operating manual - Compressed air eccentric sander	13
(F)	Notice d'utilisation d'origine - Ponceuse excentrique pneumatique	19
(E)	Manual de instrucciones original - Lijadora excéntrica de aire comprimido	26
(I)	Istruzioni per l'uso originali - Levigatrice orbitale pneumatica	33
(NL)	Originele gebruiksaanwijzing - Perslucht-excenterschuurmachine	40
(S)	Originalbruksanvisning - Tryckluftsexcenterslip	46
(FIN)	Alkuperäiset käyttöohjeet - Paineilma-epäkeskoihomakoneet	52
(DK)	Original brugsanvisning - Trykluft-excentersliber	58
(N)	Originalbruksanvisning - Trykkluft-eksentersliper	64
(P)	Manual de instruções original - Lixadora excêntrica pneumática	70
(RUS)	Оригинал Руководства по эксплуатации - Эксцентриковая пневмошлифмашинка	77
(CZ)	Originál návodu k obsluze - Pneumatické excentrické brusky	84
(PL)	Oryginalna instrukcja eksploatacji - Pneumatyczna szlifierka momośrodowa	90

**LEX 3 77/2,5**  
**LEX 3 125/3**  
**LEX 3 125/5**  
**LEX 3 150/3**  
**LEX 3 150/5**  
**LEX 3 150/7**

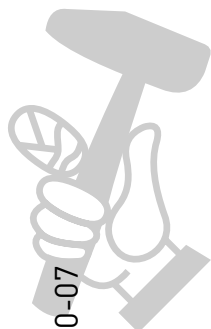

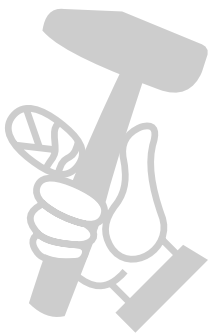
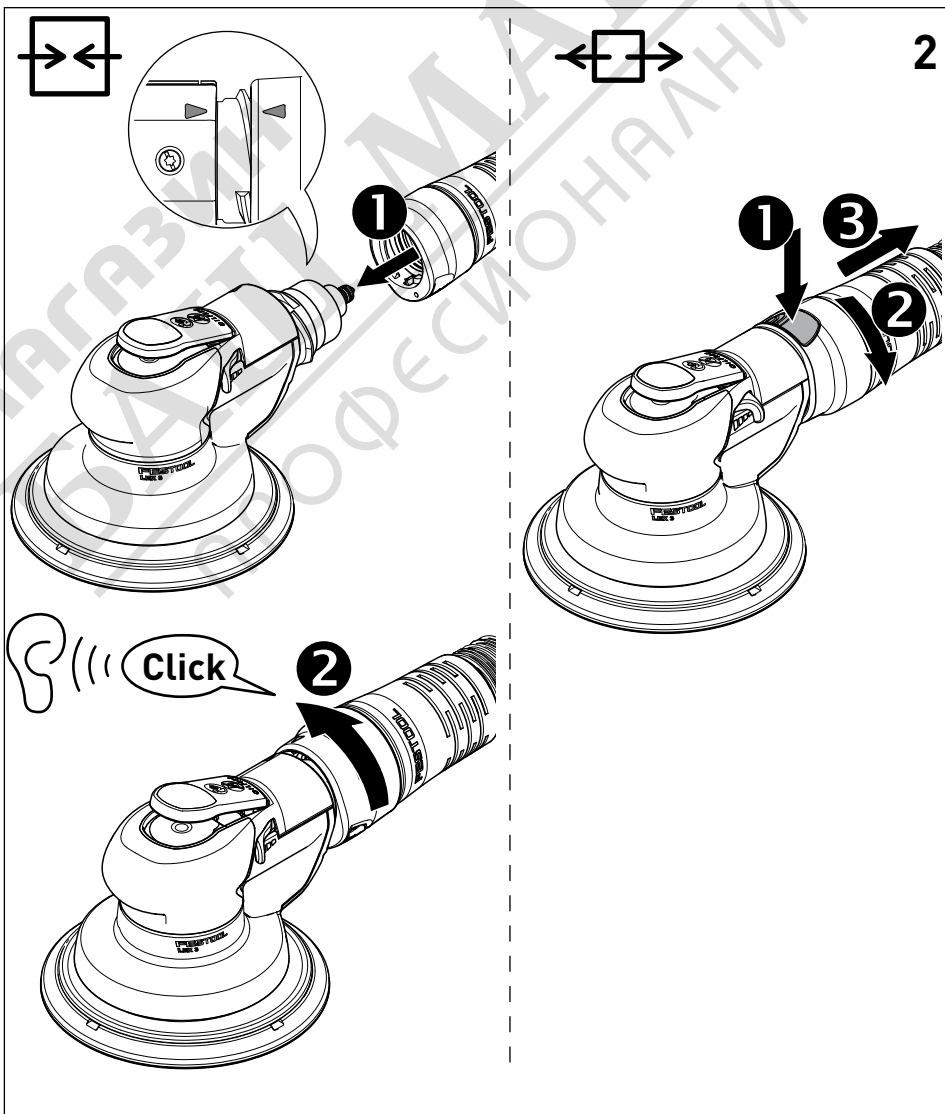
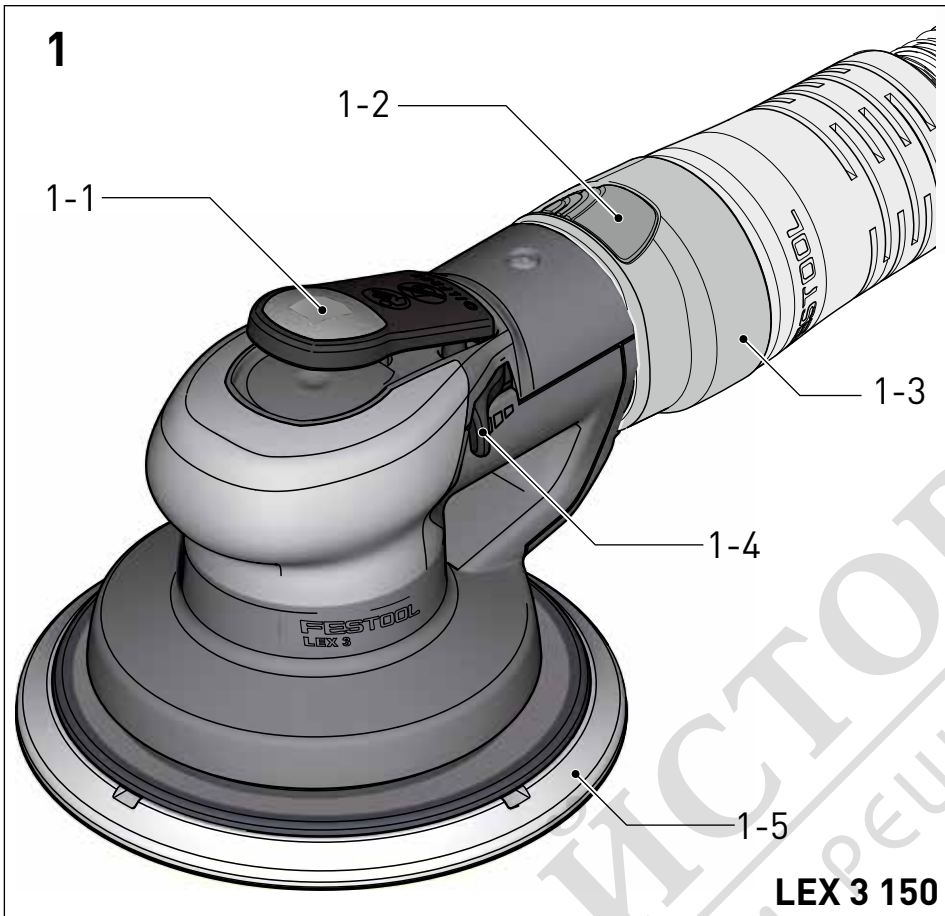

### IAS-3/IAS-2

3-1  
3-2  
3-3

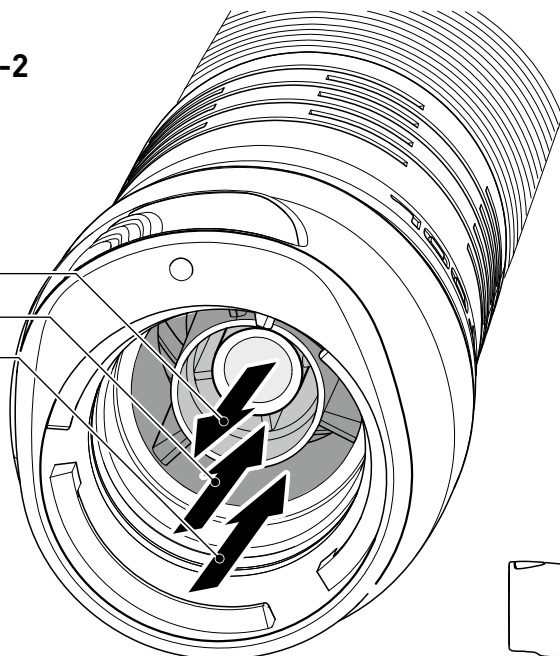

### IAS-3 light

3-1  
3-2  
3-3

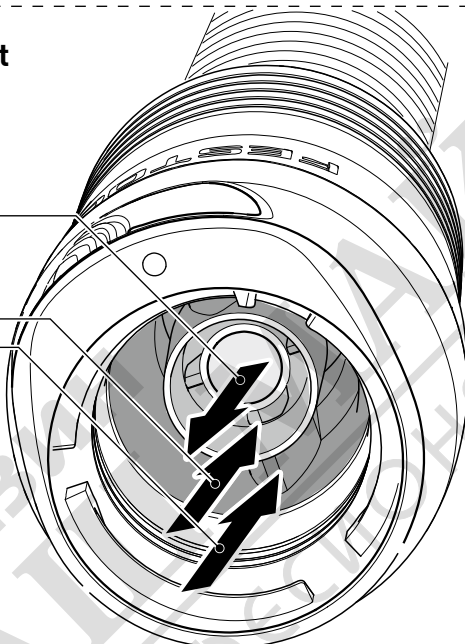

### IAS-3 SD

3-1  
3-2

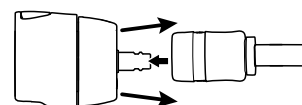
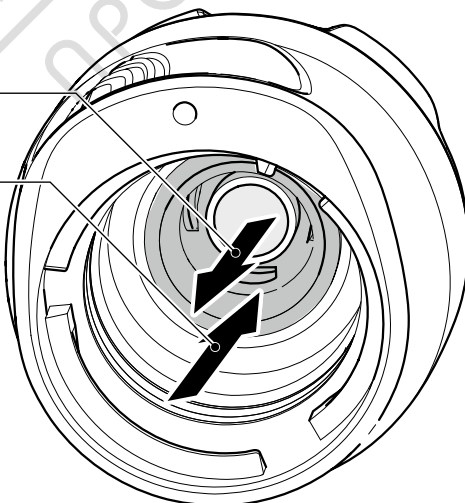

МАГАЗИН ПРОФЕССИОНАЛЬНЫХ РЕШЕНИЙ  
ФАКТОРА

4

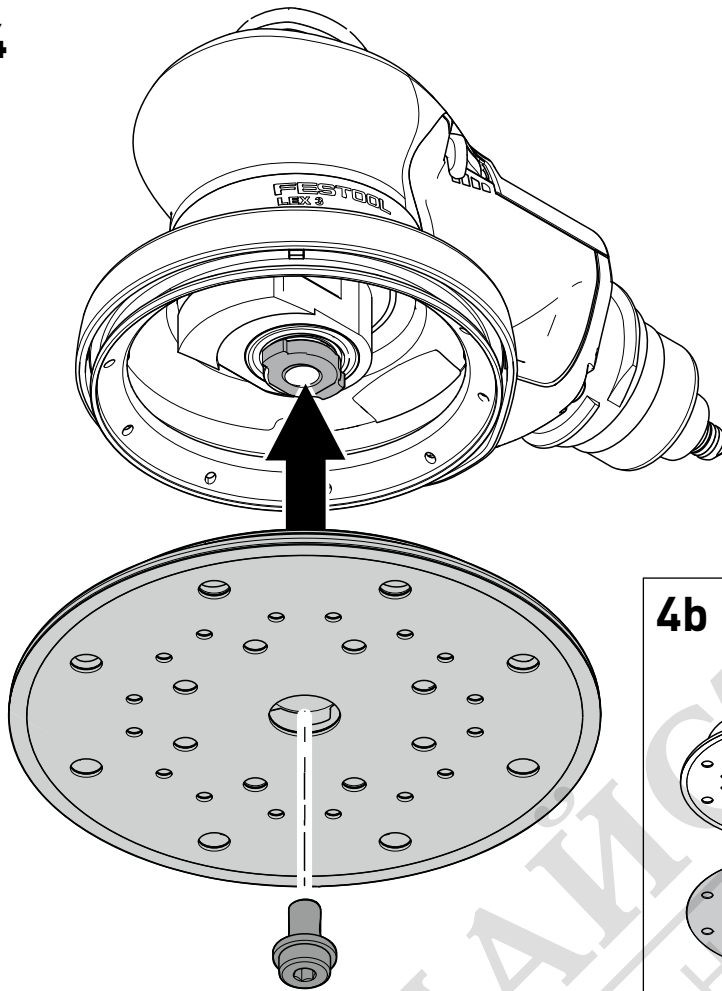

4b

StickFix

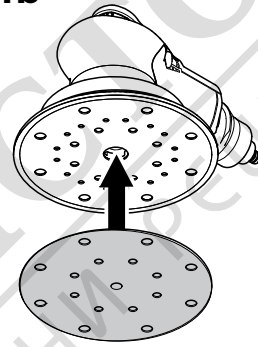

5

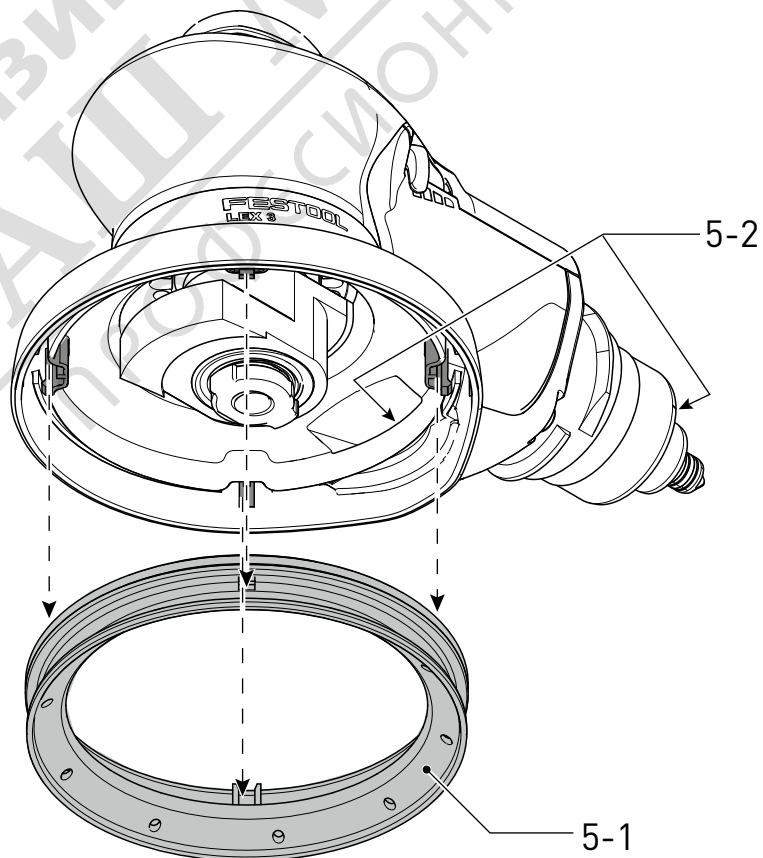

5-2

5-1

## Original operating manual

### 1 Symbols

#### Sym- Significance bol



Warning of general danger



Read instruction manual!



Wear ear protection.



Wear protective goggles.



Wear a dust mask.



Do not dispose of as domestic waste.

### 2 Safety instructions

#### 2.1 General safety instructions

##### General safety regulations



**Warning! Before setting up, using, repairing and servicing this compressed air tool or replacing accessory parts, you must have read and understood all safety instructions and information.** Ignoring warning notes and instructions may result in serious injuries.

- Only trained and qualified persons are permitted to set up, adjust and operate this compressed air tool. Persons without the relevant qualifications and training are more likely to cause accidents.
- This compressed air tool may not be modified. Modifications may reduce the effectiveness of safety devices and pose a greater risk to operating personnel.
- Keep all of the attached documents and pass on the documentation if the machine changes ownership.
- Never use a damaged compressed air tool.
- Regularly inspect compressed air tool. The compressed air tool must be marked with clearly legible rated values and markings. Replacement signs can be ordered from the manufacturer.

##### Danger from ejected parts

- In the event the workpiece, accessory or machine parts break parts may be ejected at high speed.
- Wear impact-resistant protective goggles.
- Wear a helmet when doing overhead work. Also assess the risks for other people.
- Secure the workpiece. Use clamping devices or a

vice to hold the workpiece firmly.

##### Risk of getting caught

- Wear suitable protective clothing! Do not wear loose clothing or jewellery. They can be caught by moving parts. Wear a hair net if you have long hair.

##### Risks during operation

- Wear protective gloves.
- Operating and maintenance personnel must be physically strong enough to handle the size, weight and power of the machine.
- Hold the machine correctly. Prepare to counteract normal or sudden movements - hold the machine with both hands.
- Avoid abnormal posture. Ensure secure stance and keep your balance at all times.
- Enable the command device for starting and shutting down in case of an interruption to the energy supply.
- The machine can only be operated with abrasives which were developed for this purpose.
- Use only lubricants recommended by the manufacturer.
- Check sanding pad before each use. Do not use the sanding pad if it is torn, broken or has fallen.
- Avoid direct contact with the sanding pad. Wear suitable gloves as protection.
- Never use without an abrasive.
- Risk of an electrostatic discharge if the compressed air tool is used on plastic and other non-conductible materials.
- Potentially explosive atmosphere: If explosive or self-igniting dust is produced during sanding of certain materials, the processing instructions of the material manufacturer must be observed under all circumstances.

##### Risk through repeated movements

- The use of the compressed air tool may cause unpleasant sensations in the hands and arms of the operator, as well as in the neck and shoulder area or other body parts.
- Adopt a comfortable posture. Change posture if working continuously.
- If symptoms such as malaise, complaints, throbbing, pain, tingling, numbness, burning or stiffness occur inform your employer and consult a doctor.

##### Risk as a result of accessory parts

- Disconnect the compressed air hose from the compressed air supply. In the event of non-use of

the compressed air tool, before maintenance and when changing insertion tools.

- Avoid contact with the insertion tool during and after use.
- Always use original accessories.
- Grinding wheels and cutting-off wheels are not permitted.
- The permissible rotational speed of the accessory must be at least 1,000 rpm higher than the maximum speed specified on the machine. Accessories that rotate faster than the permissible level can rupture.
- Self-adhesive abrasives must be attached concentrically on the sanding pad.

#### **Risk at work station**

- Slipping and tripping hazard! Pay attention to slippery surfaces and tripping hazards as a result of air pressure hoses.
- Not intended for use in explosive atmospheres and not insulated against contact with electrical power sources.
- Proceed with caution in unfamiliar surroundings that may contain electrical or other supply cables that harbour hidden dangers. Ensure that there are no electrical cables, gas pipelines or similar that, if damaged, could pose a hazard when the machine is used.

#### **Hazard as a result of dust and vapours**

- If hazardous dust is produced during sanding, the machine should be connected to an appropriate extractor and the safety regulations that apply to the working material should be observed.
- A risk assessment in relation to this hazard must be carried out and corresponding control mechanisms implemented. Arising dust must be factored in.
- Connect the dust extractor. Make sure that available dust extraction equipment is connected and used correctly. Observe the regional safety regulations for hazardous dusts and vapours. Operate and service the compressed air tool as described in the recommendations included in these instructions and use accessories and attachments from Festool to minimise the release of dust and vapours into the atmosphere. In dusty environments, make sure that the dissipation of exhaust air does not disturb the dust.
- If necessary arising dust or vapours must be controlled at the place of their release.
- All components must be fitted correctly and meet

all requirements to ensure that the compressed air tool operates correctly.

- Select, maintain and replace accessories and consumables according to these operating instructions.
- Wear a dust mask. Observe instructions from the employer or occupational and health regulations.

#### **Noise hazard**

- Higher noise level can lead to permanent hearing damage, loss of hearing or other problems if inadequate hearing protection is not worn or available.
- A risk assessment in relation to this hazard must be carried out and corresponding control mechanisms implemented, e.g. the use of insulating materials.
- Wear ear protection. Observe instructions from the employer or occupational and health regulations.
- Operate and maintain compressed air tool according to these operating instructions.
- Select, maintain and replace accessories and consumables according to these operating instructions.
- Assure function of the silencer at the compressed air tool.

#### **Vibration hazard**

- Vibrations can cause damage to nerves and problems with blood circulation in hands and arms.
- When working in cold environments wear warm clothing and keep hands warm and dry.
- In the event of numbness, tingling or pains in fingers or hands or white colouration of the fingers or hands, cease work, inform employer and consult a doctor.
- Operate and maintain compressed air tool according to these operating instructions.
- Do not hold the compressed air tool too tight, but with a secure grip while observing the necessary hand reaction forces. The vibration risk is greater with increasing gripping strength.

#### **Additional safety information for pneumatic machines**

- Compressed air can cause serious injuries.
  - Disconnect the compressed air hose from the compressed air supply. In the event of non-use of the compressed air tool, before maintenance and when changing insertion tools.

- Never direct the air flow towards yourself or other persons.
- Hoses flapping around can cause serious injuries. Check whether hoses and their fixing devices have not suffered damage or become loose.
- The operating pressure should not exceed 6.2 bar.
- The machine must not be operated at a higher speed than 10500 (LEX 3 77)/ 9500 (LEX 3 125)/ 10000 (LEX 3 150) min<sup>-1</sup>
- Never carry the compressed air tool by the compressed air hose.

#### Further safety information

- **Keep your work area tidy.** Untidiness in the work area can cause accidents.
- **Take into consideration environmental influences.** Do not leave compressed air tools out in the rain.
- **Keep away from children!** Do not allow others to touch the compressed air tool or the compressed air hose. Keep others away from your work area.
- **Store your compressed air tools safely.** Unused compressed air tools should be stored in a dry, inaccessible or locked location, out of the reach of children.
- **Do not use the compressed air hose for purposes for which it was not intended.** Protect the compressed air hose from heat, oil and sharp edges. Check the compressed air hose regularly and if it becomes damaged, have it replaced by an approved specialist. The compressed air hose cannot be used for application devices such as atomising and spraying equipment as the safety requirements against electrical hazards cannot be satisfied.
- **Take good care of your tools.** Keep the tools sharp and clean to enable better and safer work. Follow the maintenance regulations and the information about tool replacement. Keep handles dry and free of oil and grease.
- **Do not leave any tool key inserted.** Before switching on check that key and adjustment tools are removed.
- **Avoid unintended start-up.** Do not carry a compressed air tool that is connected to a com-

pressed air supply with your finger on the trigger. When connecting the compressed air hose to a compressed air supply, make sure that the switch is not activated.

- **Be alert!** Pay attention to what you are doing. Always work with care.

Do not use the compressed air tool if you are not able to concentrate properly.

- **Have** your compressed air tool repaired by a qualified specialist. This compressed air tool corresponds to the relevant safety regulations. Repairs should only be carried out by a qualified specialist. The operator is otherwise at risk of an accident.

- **Only work with correctly processed compressed air.** Using the Festool supply unit VE guarantees this.

- **If the compressed air tool is dropped or falls, check for damage to the machine and sanding pad. Remove the sanding pad for closer inspection. Repair damaged parts before using again.** Broken sanding pads and damaged machines can cause injuries and machine instability.

- **Clean work equipment soaked in oils, for example sanding pad or polishing felt, with water and allow to dry.** Work equipment soaked in oil may combust spontaneously.

- **Always use anti-static hoses and an earthed extraction system. The system components offered by Festool satisfy these requirements.** An un-earthed extractor system or hoses that are not anti-static may cause electric shocks and severe injuries.

#### 2.2 Other risks

In spite of compliance with all relevant design regulations, dangers may still present themselves when the machine is operated, e.g.:

- Workpiece parts being thrown off,
- Parts of damaged tools being thrown off,
- Noise emissions,
- Dust emissions.

## 2.3 Emission levels

Levels determined in accordance with EN ISO 15744/ISO 28927 are typically:

Version	Sound pressure level / Sound power level		Vibration emission level			
			3 directions		1 direction <sup>1</sup>	
	L <sub>PFA</sub> / L <sub>WA</sub>	Uncertainty	a <sub>h</sub>	Uncertainty K	a <sub>h</sub>	Uncertainty K
	[dB(A)]		[m/s <sup>2</sup> ]	[m/s <sup>2</sup> ]	[m/s <sup>2</sup> ]	[m/s <sup>2</sup> ]
LEX 3 77/2,5	72 / 83	3	< 2.5	1.5	< 2.5	1.5
LEX 3 125/3	70 / 81	3	4.4	2.0	< 2.5	1.5
LEX 3 125/5	72 / 83	3	5.0	2.0	< 2.5	1.5
LEX 3 150/3	72 / 83	3	3.7	2.0	< 2.5	1.5
LEX 3 150/5	72 / 83	3	3.9	2.0	2.7	1.5
LEX 3 150/7	76 / 87	3	5.8	2.0	3.2	1.5

<sup>1</sup> For information: According to the old EN ISO 8662.



Wear ear protection.

The specified emission values (vibration, noise)

- are used to compare machines.
- They are also used for making preliminary estimates regarding vibration and noise loads during operation.
- They represent the primary applications of the power tool.

Increase possible for other applications, with other insertion tools or if not maintained adequately. Take note of idling and downtimes of machine!

## 3 Intended use

The compressed air eccentric sanders are suitable for sanding wood, plastic, metal, stone, composites, acrylic-based mineral materials, paint/clear coats, fillers and similar materials.

Materials containing asbestos must not be processed.

**Only** use with Festool hose system IAS 2 or IAS 3 and Festool sanding pads!



The user is liable for improper or non-intended use.

## 4 Technical data

Compressed air eccentric sander	LEX 3	LEX 3	LEX 3	LEX 3	LEX 3	LEX 3
	77/2.5	125/3	125/5	150/3	150/5	150/7
Drive	Compressed-air vane motor					
Sanding pad Ø	77 mm	125 mm		150 mm		
Sanding stroke	2,5 mm	3 mm	5 mm	3 mm	5 mm	7 mm
Idle engine speed n <sub>0</sub>	10500 rpm	9 500 rpm		10 000 rpm		
Air consumption at rated load*	270 l/min	290 l/min			310 l/min	
Air pressure						
Max. inlet pressure	6.2 bar ( 90 psi)					
Recommended minimum	5 bar ( 72.5 psi)					
Compressed air quality i.a.w. DIN ISO 8573-1	Class 5					
Recommended storage temperature / operating temperature	0° - 60° C / 10° - 40° C					
Weight	0.8 kg	1.0 kg		1.0 kg		

\* at 6 bar inlet pressure; n<sub>0</sub>, load 30N

## 5 Machine features

- [1-1] On/Off switch
- [1-2] Button for loosening the IAS connection
- [1-3] IAS connection adapter
- [1-4] Speed control
- [1-5] Sanding pad

The specified illustrations appear at the beginning of the Operating Instructions.

Accessories shown or described are sometimes not included in the scope of delivery.

## 6 Compressed-air supply and commissioning



### CAUTION

#### Risk of injury

- Make sure that the pneumatic tool is switched off when you connect the compressed-air supply.

### 6.1 Compressed air preparation

The machine is designed for lubricated operation and must be operated with the Festool service unit. Comprising a filter, controller, condensate outlet and oiler, it ensures clean, oiled compressed air free of condensation. The oiler must be adjusted so that approx. every 15 minutes a drop of oil is added to the compressed air. The correct setting depends on the daily usage time.



Damage occurring from inadequate compressed air preparation is excluded from the warranty.

If using up to two Festool air tools we recommend the service unit with a 3/8" connection.

For the compressed air supply a compressor which delivers at least 350 l/min at an operating pressure of 6 bar must be selected.

The line system must have a sufficiently big diameter (min. 9 mm).

### 6.2 Connection for IAS hose system [2]

The IAS hose system combines several functions in one hose depending on the version:

- Compressed air supply [3-1]
- Exhaust air extraction [3-2]
- Dust extraction [3-3]

### 6.3 Switch on/off

Switching-on: Press [1-1] switch.

Switching off: Release [1-1] switch.

## 7 Settings



### CAUTION

#### Risk of injury

- The machine should always be disconnected from the compressed air supply before any work is carried out on the machine.

### 7.1 Setting and adjusting the speed

Can be adjusted at the control lever [1-4] between

LEX 3 77/2,5 7800 - 10500 min<sup>-1</sup>

LEX 3 125/3, 125/5 7000 - 9500 min<sup>-1</sup>

LEX 3 150/3, 150/5, 150/7 7000 - 10000 min<sup>-1</sup>

This enables you to optimise the material removal capacity to suit the respective material or application.

### 7.2 Replacing the sanding pad [4]



An optimal work result can only be achieved using original accessories and consumables. The use of non-original accessories or consumables invalidates the right to claim under warranty.



**Health risk:** Fitting sanding pads of incorrect size causes excessive vibration of the machine.

Tuned to the surface being processed, the machine can be equipped with three sanding pads of different hardnesses.

**Hard:** Coarse and fine sanding on surfaces. Sanding edges.

**Soft:** Universal for coarse and fine sanding, for flat and convex surfaces.

**Extra-soft:** Fine sanding of moulded parts, arches, radii. Do not use on edges.

### 7.3 Attaching sanding accessories using StickFix [4b]

The suitable StickFix sandpaper and StickFix sanding cloth can be attached quickly and simply to the StickFix sanding pad.

- Press the self-adhesive sanding accessory onto the sanding pad [1-5].



In the case of a weakening adhesive effect of the StickFix surface, the sanding pad accessories, in particular those which are not yet touching the workpiece, **may come loose from the sanding pad and cause injuries.** Replace the sanding pad!

## 7.4 Dust extraction



### WARNING

#### Dust hazard

- ▶ Always work with a dust extractor.
- ▶ Always observe country-specific regulations.

① For use of a Festool mobile dust extractor **with flow sensor**: Adjust hose diameter of mobile dust extractor to  $\varnothing$  27 mm.

To guarantee optimal dust extraction, we recommend using Festool extractors with automatic switch-on/switch-off device for compressed air machines.

 In order to prevent damage to the pneumatic motor, dust extraction must not be carried out on the pneumatic tool when it is at standstill.

### 8 Working with the machine

 Please observe all mentioned safety informations and the following rules when working:

- Always secure the workpiece in such a manner that it cannot move while being processed.

 For work that generates dust, wear a dust mask.

- The pad foam becomes brittle due to ageing. Before working, check the pad foam for wear.

### 9 Service and maintenance



### WARNING

#### Risk of injury

- ▶ The machine should always be disconnected from the compressed air supply before any work is carried out on the machine.
- ▶ All maintenance and repair work which requires the motor casing to be opened may only be carried out by an authorised service centre.



**Customer service and repair** only through manufacturer or service workshops: Please find the nearest address at: [www.festool.com/service](http://www.festool.com/service)



Only use original Festool spare parts! Order No. at: [www.festool.com/service](http://www.festool.com/service)

#### 9.1 Vanes

We recommend that the vanes on the motor be replaced after approx. 2000 operating hours.

#### 9.2 Replacing the silencer

In order to maintain the power and performance of the compressed air tool, replace the silencer on the IAS hose systems at regular intervals.

#### 9.3 Sanding pad brake

The rubber sleeve [5-1] brushes off the sanding pad and prevents uncontrolled turning of the sanding pad. This must be replaced if the braking effect decreases.

#### 9.4 Cleaning the extraction channels

We recommend cleaning the extraction channels in the machine [5-2] roughly once a week (particularly if sanding synthetic resin, in the case of wet sanding and if sanding plaster) using a small flat brush or a cloth.

### 10 Accessories

The order numbers of the accessories and tools can be found in the Festool catalogue or on the Internet under "[www.festool.com](http://www.festool.com)".

### 11 Environment

**Do not dispose of the device as domestic waste!** Dispose of machines, accessories and packaging at an environmentally responsible recycling centre. Observe the respective national regulations.

**Information on REACH:** [www.festool.com/reach](http://www.festool.com/reach)

