

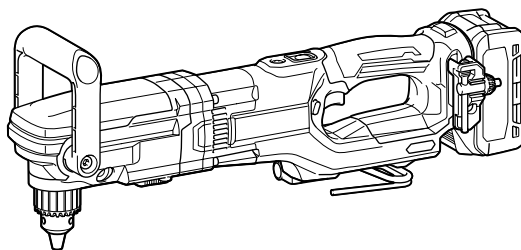

<b>EN</b>	Cordless Angle Drill	INSTRUCTION MANUAL	5
<b>FR</b>	Perceuse d'Angle sans Fil	MANUEL D'INSTRUCTIONS	12
<b>DE</b>	Akku-Winkelbohrmaschine	BETRIEBSANLEITUNG	20
<b>IT</b>	Trapano angolare a batteria	ISTRUZIONI PER L'USO	28
<b>NL</b>	Haakse accuboormachine	GEBRUIKSAANWIJZING	36
<b>ES</b>	Taladro Angular Inalámbrico	MANUAL DE INSTRUCCIONES	44
<b>PT</b>	Furadeira Angular a Bateria	MANUAL DE INSTRUÇÕES	52
<b>DA</b>	Akku vinkelboremaskine	BRUGSANVISNING	60
<b>EL</b>	Φορητό γωνιακό τρυπάνι	ΕΓΧΕΙΡΙΔΙΟ ΟΔΗΓΙΩΝ	67
<b>TR</b>	Akülü Açılı Matkap	KULLANMA KILAVUZU	75

**DA001G**



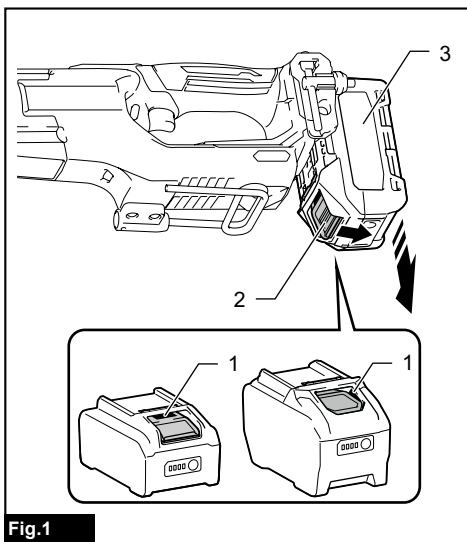

Fig.1

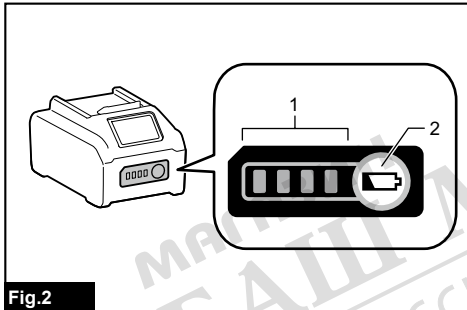

Fig.2

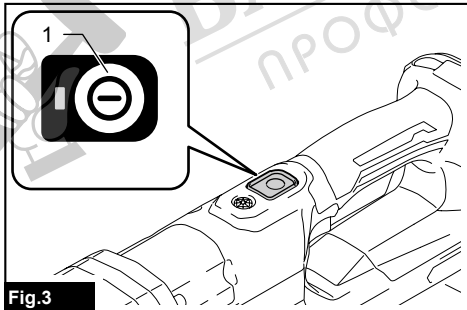

Fig.3

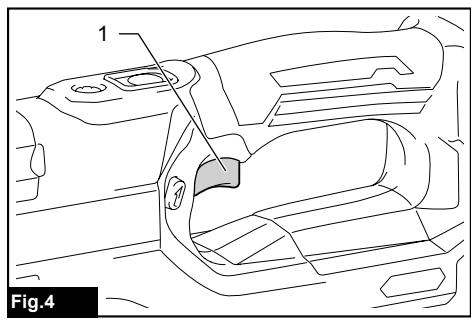

Fig.4

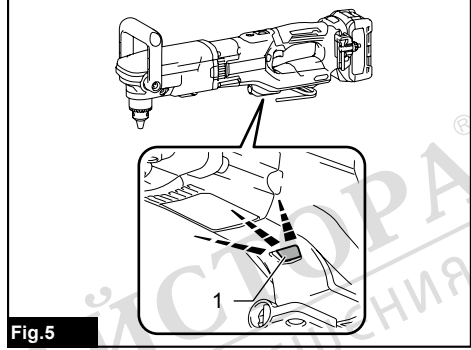

Fig.5

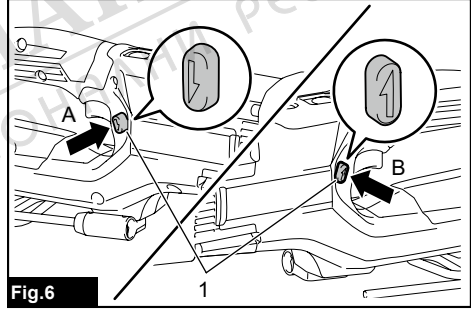

Fig.6

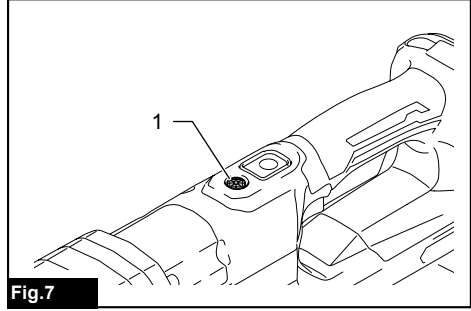
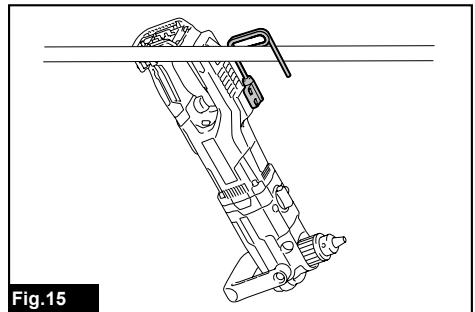
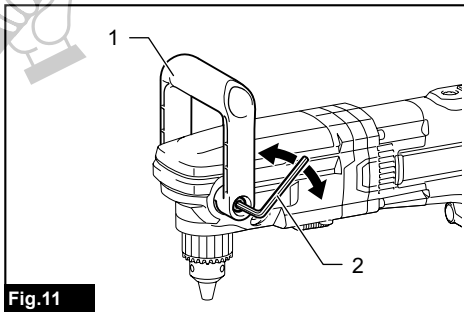
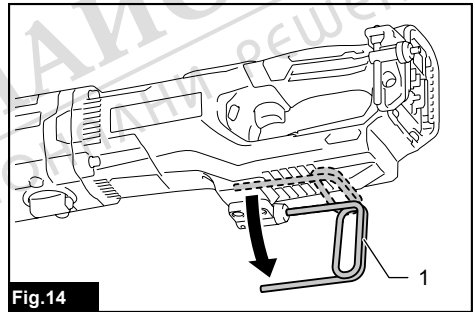
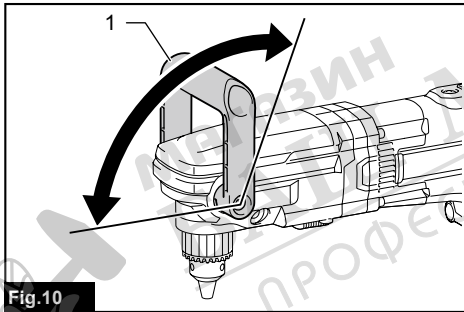
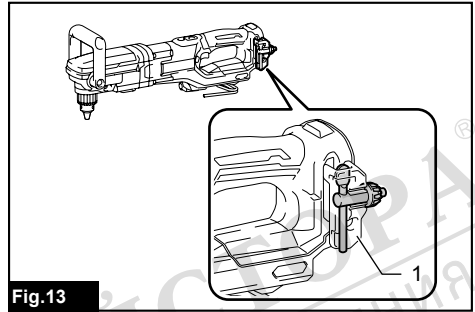
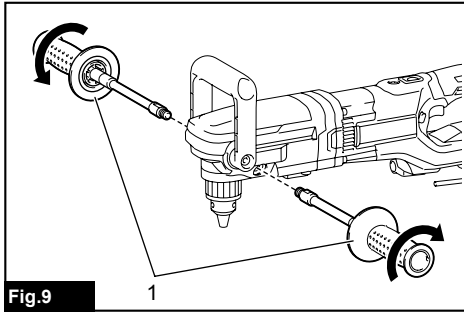
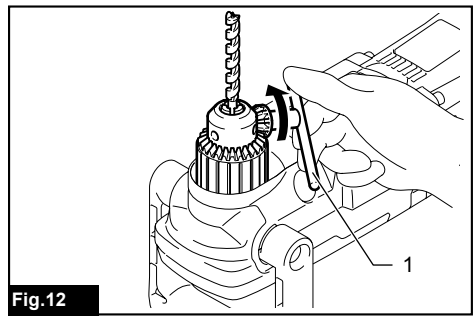
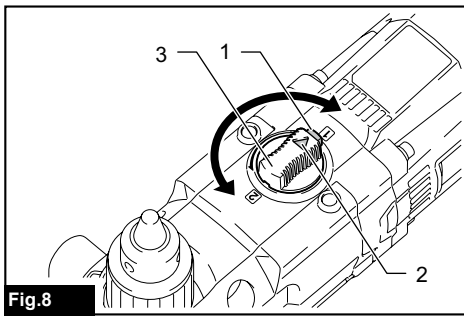
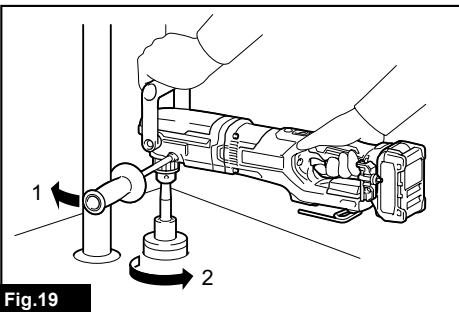
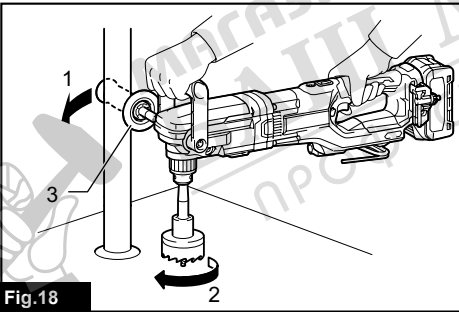
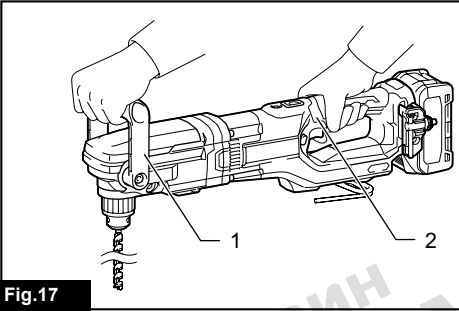
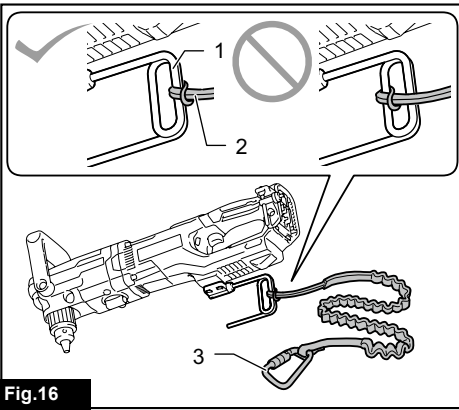

Fig.7





## SPECIFICATIONS

<b>Model:</b>		<b>DA001G</b>	
Gear speed		High	Low
Drilling capacities (Diameter)	Steel	13 mm	
	Wood	Auger bit: 50 mm Self-feed bit: 65 mm Hole saw: 105 mm	Auger bit: 50 mm Self-feed bit: 118 mm Hole saw: 159 mm
No load speed		0 - 1,500 min <sup>-1</sup>	0 - 400 min <sup>-1</sup>
Overall length (with battery cartridge BL4040) *With the front handle extended		545 mm * 614 mm	
Rated voltage		D.C. 36 V - 40 V max	
Net weight		5.6 - 6.8 kg	

- Due to our continuing program of research and development, the specifications herein are subject to change without notice.
- Specifications may differ from country to country.
- The weight may differ depending on the attachment(s), including the battery cartridge. The lightest and heaviest combination, according to EPTA-Procedure 01/2014, are shown in the table.

### Applicable battery cartridge and charger

Battery cartridge	BL4020 / BL4025* / BL4040* / BL4050F* / BL4080F* * : Recommended battery
Charger	DC40RA / DC40RB / DC40RC

- Some of the battery cartridges and chargers listed above may not be available depending on your region of residence.

**⚠WARNING:** Only use the battery cartridges and chargers listed above. Use of any other battery cartridges and chargers may cause injury and/or fire.

### Intended use

The tool is intended for drilling in wood, metal and plastic.

### Noise

The typical A-weighted noise level determined according to EN62841-2-1:

Sound pressure level ( $L_{pA}$ ) : 84 dB(A)

Sound power level ( $L_{WA}$ ) : 95 dB (A)

Uncertainty (K) : 3 dB(A)

**NOTE:** The declared noise emission value(s) has been measured in accordance with a standard test method and may be used for comparing one tool with another.

**NOTE:** The declared noise emission value(s) may also be used in a preliminary assessment of exposure.

**⚠WARNING:** Wear ear protection.

**⚠WARNING:** The noise emission during actual use of the power tool can differ from the declared value(s) depending on the ways in which the tool is used especially what kind of workpiece is processed.

**⚠WARNING:** Be sure to identify safety measures to protect the operator that are based on an estimation of exposure in the actual conditions of use (taking account of all parts of the operating cycle such as the times when the tool is switched off and when it is running idle in addition to the trigger time).

### Vibration

The vibration total value (tri-axial vector sum) determined according to EN62841-2-1:

Work mode: drilling into metal

Vibration emission ( $a_{h,D}$ ) : 2.5 m/s<sup>2</sup> or less

Uncertainty (K) : 1.5 m/s<sup>2</sup>

**NOTE:** The declared vibration total value(s) has been measured in accordance with a standard test method and may be used for comparing one tool with another.

**NOTE:** The declared vibration total value(s) may also be used in a preliminary assessment of exposure.

**⚠WARNING:** The vibration emission during actual use of the power tool can differ from the declared value(s) depending on the ways in which the tool is used especially what kind of workpiece is processed.

**⚠WARNING:** Be sure to identify safety measures to protect the operator that are based on an estimation of exposure in the actual conditions of use (taking account of all parts of the operating cycle such as the times when the tool is switched off and when it is running idle in addition to the trigger time).

## EC Declaration of Conformity

### For European countries only

The EC declaration of conformity is included as Annex A to this instruction manual.

## SAFETY WARNINGS

### General power tool safety warnings

**⚠ WARNING:** Read all safety warnings, instructions, illustrations and specifications provided with this power tool. Failure to follow all instructions listed below may result in electric shock, fire and/or serious injury.

### Save all warnings and instructions for future reference.

The term "power tool" in the warnings refers to your mains-operated (corded) power tool or battery-operated (cordless) power tool.

### Cordless drill safety warnings

#### Safety instructions for all operations

1. Use the auxiliary handle(s). Loss of control can cause personal injury.
2. Brace the tool properly before use. This tool produces a high output torque and without properly bracing the tool during operation, loss of control may occur resulting in personal injury.
3. Hold the power tool by insulated gripping surfaces, when performing an operation where the cutting accessory may contact hidden wiring. Cutting accessory contacting a "live" wire may make exposed metal parts of the power tool "live" and could give the operator an electric shock.
4. Always be sure you have a firm footing. Be sure no one is below when using the tool in high locations.
5. Hold the tool firmly.
6. Keep hands away from rotating parts.
7. Do not leave the tool running. Operate the tool only when hand-held.
8. Do not touch the drill bit or the workpiece immediately after operation; they may be extremely hot and could burn your skin.
9. Some material contains chemicals which may be toxic. Take caution to prevent dust inhalation and skin contact. Follow material supplier safety data.
10. If the drill bit cannot be loosened even you open the jaws, use pliers to pull it out. In such a case, pulling out the drill bit by hand may result in injury by its sharp edge.
11. If something wrong with the tool such as abnormal sounds, stop operating immediately and ask your local Makita Service Center for repair.
12. Before operation, make sure that there is no buried object such as electric pipe, water pipe or gas pipe in the ground. Otherwise, the tool may touch them, resulting an electric shock, electrical leakage or gas leak.

#### Safety instructions when using long drill bits

1. Never operate at higher speed than the maximum speed rating of the drill bit. At higher speeds, the bit is likely to bend if allowed to rotate freely without contacting the workpiece, resulting in personal injury.
2. Always start drilling at low speed and with the bit tip in contact with the workpiece. At higher speeds, the bit is likely to bend if allowed to rotate freely without contacting the workpiece, resulting in personal injury.
3. Apply pressure only in direct line with the bit and do not apply excessive pressure. Bits can bend causing breakage or loss of control, resulting in personal injury.

### SAVE THESE INSTRUCTIONS.

**⚠ WARNING:** DO NOT let comfort or familiarity with product (gained from repeated use) replace strict adherence to safety rules for the subject product. MISUSE or failure to follow the safety rules stated in this instruction manual may cause serious personal injury.

### Important safety instructions for battery cartridge

1. Before using battery cartridge, read all instructions and cautionary markings on (1) battery charger, (2) battery, and (3) product using battery.
2. Do not disassemble or tamper the battery cartridge. It may result in a fire, excessive heat, or explosion.
3. If operating time has become excessively shorter, stop operating immediately. It may result in a risk of overheating, possible burns and even an explosion.
4. If electrolyte gets into your eyes, rinse them out with clear water and seek medical attention right away. It may result in loss of your eyesight.
5. Do not short the battery cartridge:
  - (1) Do not touch the terminals with any conductive material.
  - (2) Avoid storing battery cartridge in a container with other metal objects such as nails, coins, etc.
  - (3) Do not expose battery cartridge to water or rain.A battery short can cause a large current flow, overheating, possible burns and even a breakdown.
6. Do not store and use the tool and battery cartridge in locations where the temperature may reach or exceed 50 °C (122 °F).
7. Do not incinerate the battery cartridge even if it is severely damaged or is completely worn out. The battery cartridge can explode in a fire.
8. Do not nail, cut, crush, throw, drop the battery cartridge, or hit against a hard object to the battery cartridge. Such conduct may result in a fire, excessive heat, or explosion.

9. **Do not use a damaged battery.**
10. **The contained lithium-ion batteries are subject to the Dangerous Goods Legislation requirements.** For commercial transports e.g. by third parties, forwarding agents, special requirement on packaging and labeling must be observed. For preparation of the item being shipped, consulting an expert for hazardous material is required. Please also observe possibly more detailed national regulations. Tape or mask off open contacts and pack up the battery in such a manner that it cannot move around in the packaging.
11. **When disposing the battery cartridge, remove it from the tool and dispose of it in a safe place. Follow your local regulations relating to disposal of battery.**
12. **Use the batteries only with the products specified by Makita.** Installing the batteries to non-compliant products may result in a fire, excessive heat, explosion, or leak of electrolyte.
13. **If the tool is not used for a long period of time, the battery must be removed from the tool.**
14. **During and after use, the battery cartridge may take on heat which can cause burns or low temperature burns. Pay attention to the handling of hot battery cartridges.**
15. **Do not touch the terminal of the tool immediately after use as it may get hot enough to cause burns.**
16. **Do not allow chips, dust, or soil stuck into the terminals, holes, and grooves of the battery cartridge.** It may cause heating, catching fire, burst and malfunction of the tool or battery cartridge, resulting in burns or personal injury.
17. **Unless the tool supports the use near high-voltage electrical power lines, do not use the battery cartridge near a high-voltage electrical power lines.** It may result in a malfunction or breakdown of the tool or battery cartridge.
18. **Keep the battery away from children.**

## SAVE THESE INSTRUCTIONS.

**CAUTION:** Only use genuine Makita batteries. Use of non-genuine Makita batteries, or batteries that have been altered, may result in the battery bursting causing fires, personal injury and damage. It will also void the Makita warranty for the Makita tool and charger.

## Tips for maintaining maximum battery life

1. **Charge the battery cartridge before completely discharged. Always stop tool operation and charge the battery cartridge when you notice less tool power.**
2. **Never recharge a fully charged battery cartridge. Overcharging shortens the battery service life.**
3. **Charge the battery cartridge with room temperature at 10 °C - 40 °C (50 °F - 104 °F). Let a hot battery cartridge cool down before charging it.**
4. **When not using the battery cartridge, remove it from the tool or the charger.**
5. **Charge the battery cartridge if you do not use it for a long period (more than six months).**

## FUNCTIONAL DESCRIPTION

**CAUTION:** Always be sure that the tool is switched off and the battery cartridge is removed before adjusting or checking function on the tool.

### Installing or removing battery cartridge

**CAUTION:** Always switch off the tool before installing or removing of the battery cartridge.

**CAUTION:** Hold the tool and the battery cartridge firmly when installing or removing battery cartridge. Failure to hold the tool and the battery cartridge firmly may cause them to slip off your hands and result in damage to the tool and battery cartridge and a personal injury.

► **Fig. 1:** 1. Red indicator 2. Button 3. Battery cartridge

To remove the battery cartridge, slide it from the tool while sliding the button on the front of the cartridge.

To install the battery cartridge, align the tongue on the battery cartridge with the groove in the housing and slip it into place. Insert it all the way until it locks in place with a little click. If you can see the red indicator as shown in the figure, it is not locked completely.

**CAUTION:** Always install the battery cartridge fully until the red indicator cannot be seen. If not, it may accidentally fall out of the tool, causing injury to you or someone around you.

**CAUTION:** Do not install the battery cartridge forcibly. If the cartridge does not slide in easily, it is not being inserted correctly.

### Indicating the remaining battery capacity

Press the check button on the battery cartridge to indicate the remaining battery capacity. The indicator lamps light up for a few seconds.

► **Fig. 2:** 1. Indicator lamps 2. Check button

Indicator lamps			Remaining capacity
Lighted	Off	Blinking	
■ ■ ■ ■			75% to 100%
■ ■ ■ □			50% to 75%
■ ■ □ □			25% to 50%
■ □ □ □			0% to 25%
▣ □ □ □			Charge the battery.
■ ■ □ □			The battery may have malfunctioned.
□ □ ■ ■			

**NOTE:** Depending on the conditions of use and the ambient temperature, the indication may differ slightly from the actual capacity.

**NOTE:** The first (far left) indicator lamp will blink when the battery protection system works.

## Tool / battery protection system

The tool is equipped with a tool/battery protection system. This system automatically cuts off power to the motor to extend tool and battery life. The tool will automatically stop during operation if the tool or battery is placed under one of the following conditions:

### Overload protection

When the tool/battery is operated in a manner that causes it to draw an abnormally high current, the tool stops automatically. In this situation, turn the tool off and stop the application that caused the tool to become overloaded. Then turn the tool on to restart.

### Overheat protection

When the tool/battery is overheated, the tool stops automatically and the lamp will blink. In this situation, let the tool cool down before turning the tool on again.

### Overdischarge protection

When the battery capacity is not enough, the tool stops automatically. In this case, remove the battery from the tool and charge the battery.

## Main power switch

**⚠ WARNING:** Always turn off the main power switch when not in use.

To stand by the tool, press the main power button until the main power lamp lights up. To turn off, press the main power button again.

► Fig.3: 1. Main power button

**NOTE:** This tool employs the auto power-off function. To avoid unintentional start up, the main power switch will automatically shut down when the switch trigger is not pulled for a certain period after the main power switch is turned on.

## Switch action

**⚠ CAUTION:** Before installing the battery cartridge into the tool, always check to see that the switch trigger actuates properly and returns to the "OFF" position when released.

► Fig.4: 1. Switch trigger

To start the tool, pull the switch trigger with the main power switch on. Tool speed is increased by increasing pressure on the switch trigger. Release the switch trigger to stop.

**NOTE:** The tool automatically stops if you keep pulling the switch trigger for about 6 minutes.

## Lighting up the front lamp

**⚠ CAUTION:** Do not look in the light or see the source of light directly.

► Fig.5: 1. Lamp

Pull the switch trigger to light up the lamp. The lamp keeps on lighting while the switch trigger is being pulled. The lamp goes out approximately 10 seconds after releasing the switch trigger.

**NOTE:** When the tool is overheated, the tool stops automatically and the lamp starts flashing. In this case, release the switch trigger. The lamp turns off in 5 minute(s).

**NOTE:** Use a dry cloth to wipe the dirt off the lens of the lamp. Be careful not to scratch the lens of lamp, or it may lower the illumination.

## Reversing switch action

**⚠ CAUTION:** Always check the direction of rotation before operation.

**⚠ CAUTION:** Use the reversing switch only after the tool comes to a complete stop. Changing the direction of rotation before the tool stops may damage the tool.

**⚠ CAUTION:** When not operating the tool, always set the reversing switch lever to the neutral position.

This tool has a reversing switch to change the direction of rotation. Depress the reversing switch lever from the A side for clockwise rotation or from the B side for counterclockwise rotation. When the reversing switch lever is in the neutral position, the switch lever cannot be pulled.

► Fig.6: 1. Reversing switch lever

## Automatic speed change function

This tool has "high speed mode" and "high torque mode". The tool automatically changes the operation mode depending on the work load. When the work load is low, the tool will run in the "high speed mode" for quicker operation. When the work load is high, the tool will run in the "high torque mode" for powerful operation.

► Fig.7: 1. Mode indicator

The mode indicator lights up in green when the tool is running in "high torque mode".

If the tool is operated with excessive load, the mode indicator will blink in green. The mode indicator stops blinking and then lights up or turns off if you reduce the load on the tool.

Mode indicator status			Operation mode
● On	○ Off	● Blinking	
	○		High speed mode
	●		High torque mode
	●	●	Overload alert



## Speed change

**NOTICE:** Use the speed change knob only after the tool comes to a complete stop. Changing the tool speed before the tool stops may damage the tool.

**NOTICE:** Always set the speed change knob carefully into the correct position. If you operate the tool with the speed change knob positioned halfway between the position 1 and the position 2, the tool may be damaged.

Two speed ranges can be preselected with the speed change knob.

To change the speed, depress the lock button and turn the speed change knob so that the pointer points to the position 1 for low speed or the position 2 for high speed.

► **Fig.8:** 1. Lock button 2. Pointer 3. Speed change knob

## Torque limiter

The torque limiter will actuate when a certain torque level is reached at the low speed setting (position 1). The motor will disengage from the output shaft. When this happens, the tool bit will stop turning.

To restart the tool, lift the tool bit out of the workpiece and then pull the switch trigger again.

## Electronic function

### Electric brake

This tool is equipped with an electric brake. If the tool consistently fails to quickly cease to function after the switch trigger is released, have the tool serviced at a Makita service center.

### Soft start feature

This function allows the smooth start-up of the tool by limiting the start-up torque.

## ASSEMBLY

**CAUTION:** Always be sure that the tool is switched off and the battery cartridge is removed before carrying out any work on the tool.

### Installing side grip (auxiliary handle)

**CAUTION:** Always be sure that the side grip is installed securely before operation.

Screw the side grip on the tool securely. The side grip can be installed on either side of the tool, whichever is convenient.

► **Fig.9:** 1. Side grip

## Front handle

**CAUTION:** Do not fix the front handle beyond the limits of the arrow as illustrated. Be cautious that your hand is not caught in the grip. Keep the hand away from the drill chuck. They can lead to serious accidents.

**CAUTION:** Always be sure that the hex bolts (both sides) of the front handle are tightened securely.

The front handle can be installed in any position within 0° - 112.5° as illustrated.

► **Fig.10:** 1. Front handle

To change the position, loosen the hex bolts (both sides) with a hex wrench and turn the front handle to the desired position. Then tighten the hex bolts securely.

► **Fig.11:** 1. Front handle 2. Hex wrench

## Installing or removing drill bit

To install the drill bit, place it in the chuck as far as it will go. Tighten the chuck by hand. Place the chuck key in each of the three holes and tighten clockwise. Be sure to tighten all three chuck holes evenly.

To remove the drill bit, turn the chuck key counterclockwise in just one hole, then loosen the chuck by hand.

► **Fig.12:** 1. Chuck key

After use, return the chuck key to the key holder on the tool as illustrated.

► **Fig.13:** 1. Key holder

## Hook

**CAUTION:** Always remove the battery when hanging the tool with the hook.

**CAUTION:** Never hook the tool at high location or on potentially unstable surface.

The hook is convenient for temporarily hanging the tool. To use the hook, simply lift up hook until it snaps into the open position. When not in use, always lower hook until it snaps into the closed position.

► **Fig.14:** 1. Hook

► **Fig.15**

## Connecting lanyard (tether strap) to the hook

**CAUTION:** Do not use damaged hook and screws. Before use, always check for damages, cracks or deformations, and make sure that the screws are tightened.

**CAUTION:** Make sure that the hook is securely installed with the screws.

**CAUTION:** Do not install or remove any accessory while hanging the tool. The tool may fall if the screws are not tightened.

**CAUTION:** Always use a locking carabiner (multi-action and screw gate type) and be sure to attach the lanyard (tether strap) to the double looped portion of the hook. Improper attachment may cause tool drop from the hook and result in personal injury.

The hook is also used for connecting the lanyard (tether strap). Be sure to connect the lanyard (tether strap) to the double looped portion of the hook.

- **Fig.16:** 1. Double looped portion of the hook  
2. Lanyard (tether strap) 3. Locking carabiner (multi-action and screw gate type)

## OPERATION

**CAUTION:** Always insert the battery cartridge all the way until it locks in place. If you can see the red indicator, it is not locked completely. Insert it fully until the red indicator cannot be seen. If not, it may accidentally fall out of the tool, causing injury to you or someone around you.

**CAUTION:** When the speed comes down extremely, reduce the load or stop the tool to avoid the tool damage.

**CAUTION:** Hold the tool firmly when operating the tool.

### Holding tool

**CAUTION:** This is a powerful tool. High torque is developed and it is important that the tool should be securely held and properly braced.

Grasp the handle with one hand and the front handle with the other hand.

- **Fig.17:** 1. Front handle 2. Handle

When drilling a large hole with a self-feed bit, etc., the side grip (auxiliary handle) should be used as a brace to maintain safe control of the tool.

When drilling action is forward (clockwise), the tool should be braced to prevent a counterclockwise reaction if the bit should bind.

- **Fig.18:** 1. Reaction 2. Forward 3. Side grip

When reversing, brace the tool to prevent a clockwise reaction. If the drill bit must be removed from a partially drilled hole, be sure the tool is properly braced before reversing.

- **Fig.19:** 1. Reaction 2. Reverse

### Drilling operation

#### Drilling in wood

When drilling in wood, the best results are obtained with wood drills equipped with a guide screw. The guide screw makes drilling easier by pulling the drill bit into the workpiece.

#### Drilling in metal

To prevent the drill bit from slipping when starting a hole, make an indentation with a center-punch and hammer at the point to be drilled. Place the point of the drill bit in the indentation and start drilling. Use a cutting lubricant when drilling metals. The exceptions are iron and brass which should be drilled dry.

**CAUTION:** Pressing excessively on the tool will not speed up the drilling. In fact, this excessive pressure will only serve to damage the tip of your drill bit, decrease the tool performance and shorten the service life of the tool.

**CAUTION:** Hold the tool firmly and exert care when the drill bit begins to break through the workpiece. There is a tremendous force exerted on the tool/drill bit at the time of hole break through.

**CAUTION:** A stuck drill bit can be removed simply by setting the reversing switch to reverse rotation in order to back out. However, the tool may back out abruptly if you do not hold it firmly.

**CAUTION:** Always secure workpieces in a vise or similar hold-down device.

**CAUTION:** Avoid drilling in material that you suspect contains hidden nails or other things that may cause the drill bit to bind or break.

**CAUTION:** If the tool is operated continuously until the battery cartridge has discharged, allow the tool to rest for 15 minutes before proceeding with a fresh battery.

### Lanyard (tether strap) connection

**Safety warnings specific for use at height**  
Read all safety warnings and instructions. Failure to follow the warnings and instructions may result in serious injury.

1. Always keep the tool tethered when working "at height". Maximum lanyard length is 2 m (6.5 ft).  
The maximum permissible fall height for lanyard (tether strap) must not exceed 2 m (6.5 ft).
2. Use only with lanyards appropriate for this tool type and rated for at least 8.0 kg (17.6 lbs).
3. Do not anchor the tool lanyard to anything on your body or on movable components. Anchor the tool lanyard to a rigid structure that can withstand the forces of a dropped tool.
4. Make sure the lanyard is properly secured at each end prior to use.
5. Inspect the tool and lanyard before each use for damage and proper function (including fabric and stitching). Do not use if damaged or not functioning properly.
6. Do not wrap lanyards around or allow them to come in contact with sharp or rough edges.
7. Fasten the other end of the lanyard outside the working area so that a falling tool is held securely.
8. Attach the lanyard so that the tool will move away from the operator if it falls. Dropped tools will swing on the lanyard, which could cause injury or loss of balance.
9. Do not use near moving parts or running machinery. Failure to do so may result in a crush or entanglement hazard.
10. Do not carry the tool by the attachment device or the lanyard.
11. Only transfer the tool between your hands while you are properly balanced.

12. Do not attach lanyards to the tool in a way that keeps guards, switches or lock-offs from operating properly.
13. Avoid getting tangled in the lanyard.
14. Keep lanyard away from the cutting area of the tool.
15. Use multi-action and screw gate type carabineers. Do not use single action spring clip carabineers.
16. In the event the tool is dropped, it must be tagged and removed from service, and should be inspected by a Makita Factory or Authorized Service Center.

## MAINTENANCE

**CAUTION:** Always be sure that the tool is switched off and the battery cartridge is removed before attempting to perform inspection or maintenance.

**NOTICE:** Never use gasoline, benzine, thinner, alcohol or the like. Discoloration, deformation or cracks may result.

To maintain product SAFETY and RELIABILITY, repairs, any other maintenance or adjustment should be performed by Makita Authorized or Factory Service Centers, always using Makita replacement parts.

## OPTIONAL ACCESSORIES

**CAUTION:** These accessories or attachments are recommended for use with your Makita tool specified in this manual. The use of any other accessories or attachments might present a risk of injury to persons. Only use accessory or attachment for its stated purpose.

If you need any assistance for more details regarding these accessories, ask your local Makita Service Center.

- Drill bits
- Side grip
- Makita genuine battery and charger

**NOTE:** Some items in the list may be included in the tool package as standard accessories. They may differ from country to country.