

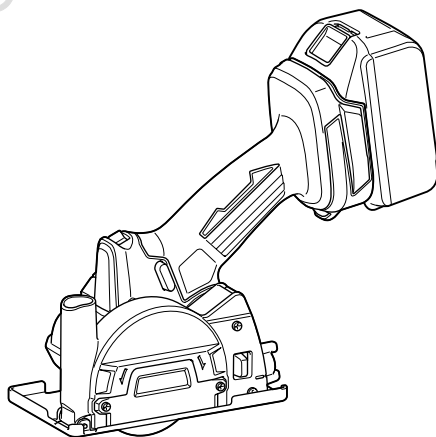

EN	Cordless Compact Cut Off	INSTRUCTION MANUAL	8
FR	Outil de coupe compact sans fil	MANUEL D'INSTRUCTIONS	17
DE	Akku-Winkelschleifer	BETRIEBSANLEITUNG	27
IT	Troncatrice compatta a batteria	ISTRUZIONI PER L'USO	37
NL	Compacte accudoorslijpmachine	GEBRUIKSAANWIJZING	47
ES	Cortador Compacto Inalámbrico	MANUAL DE INSTRUCCIONES	57
PT	Cortadora Angular a Bateria	MANUAL DE INSTRUÇÕES	67
DA	Ledningfri kompakt afskæring	BRUGSANVISNING	77
EL	Φορητό συμπαγές εργαλείο αποκοπής	ΕΓΧΕΙΡΙΔΙΟ ΟΔΗΓΙΩΝ	86
TR	Akülü Kompakt Kesici	KULLANMA KILAVUZU	97

DMC300

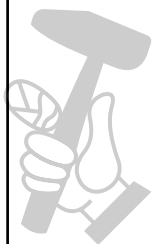

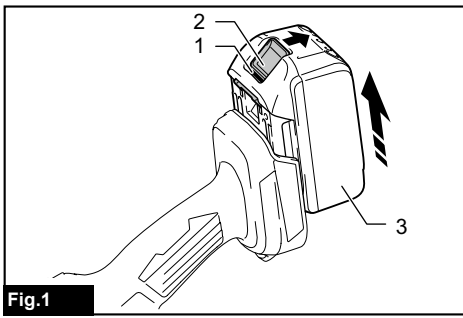

Fig.1

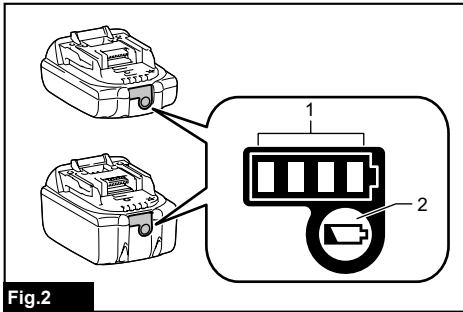

Fig.2

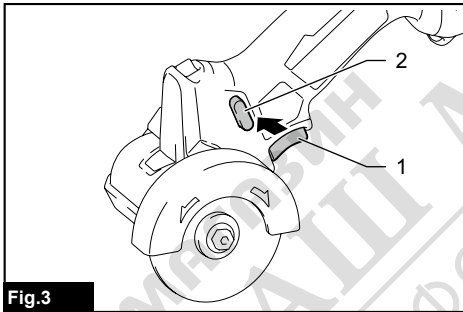

Fig.3

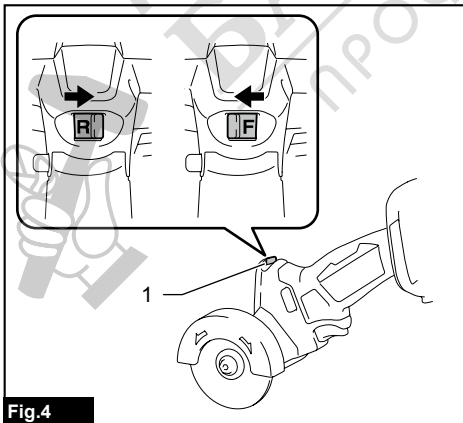

Fig.4

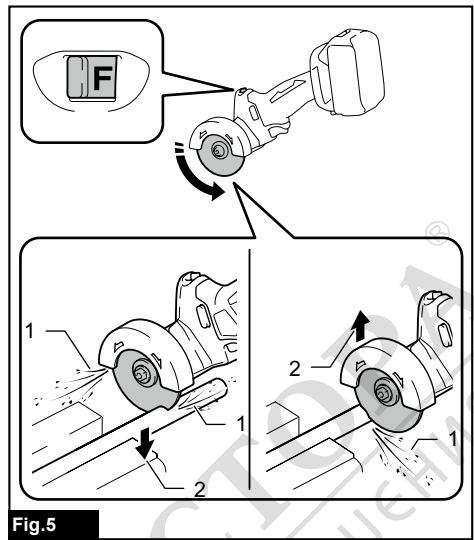

Fig.5

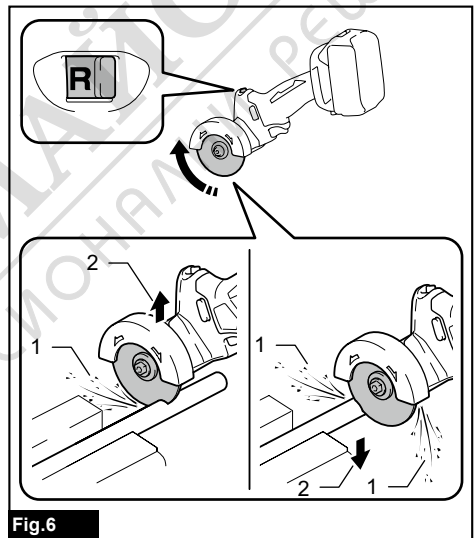

Fig.6

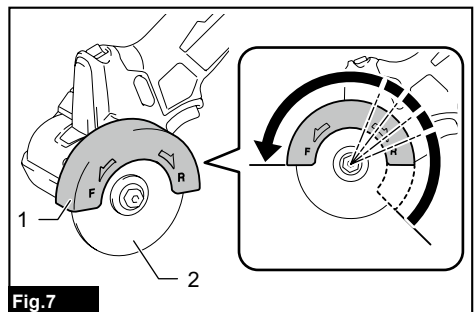
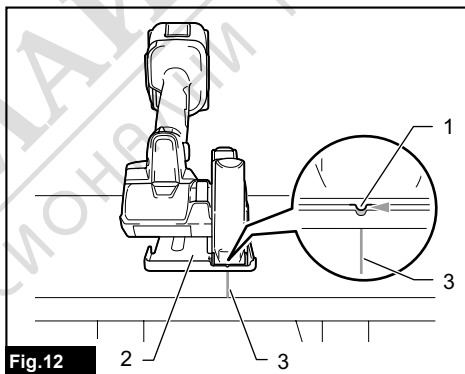
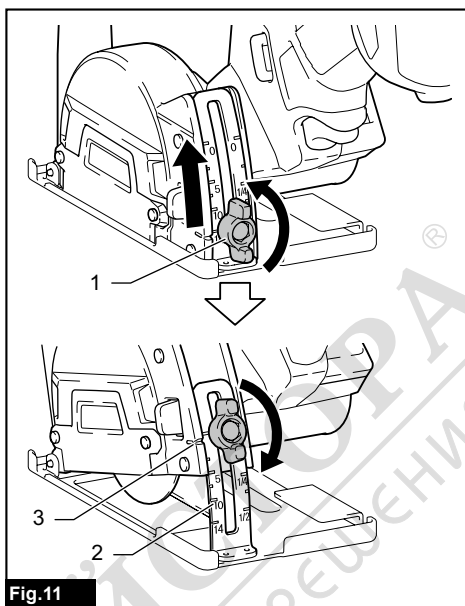
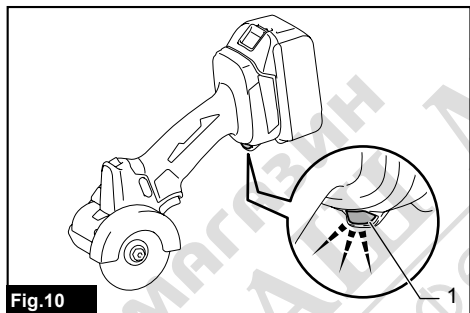
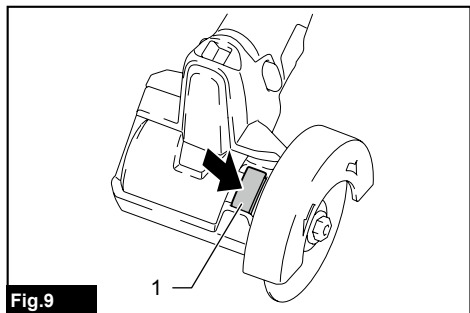
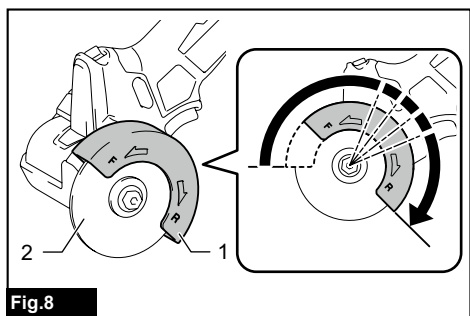

Fig.7



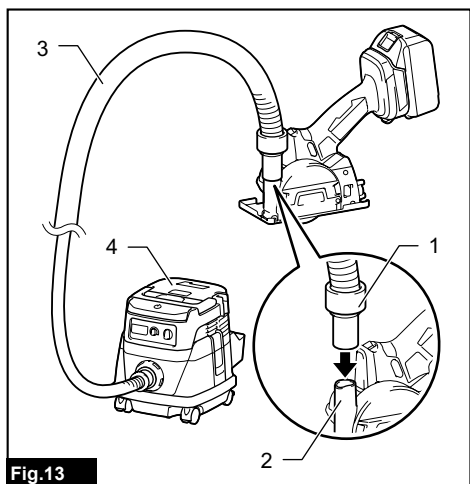

Fig.13

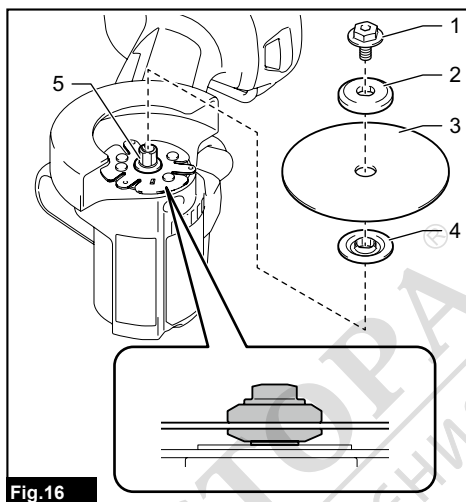

Fig.16

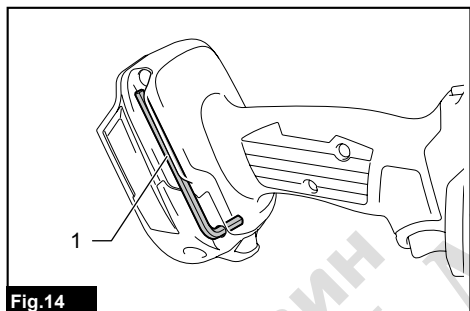

Fig.14

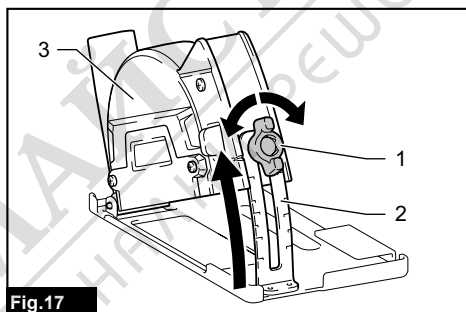

Fig.17

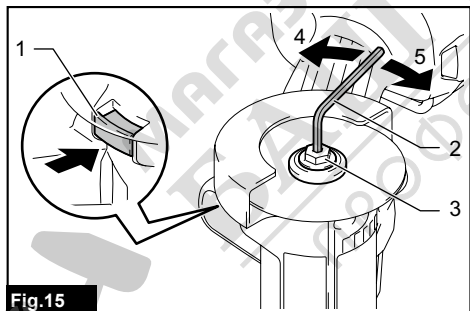

Fig.15

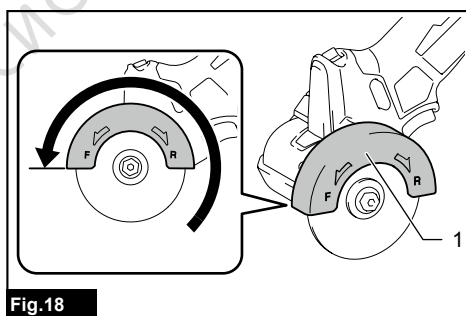
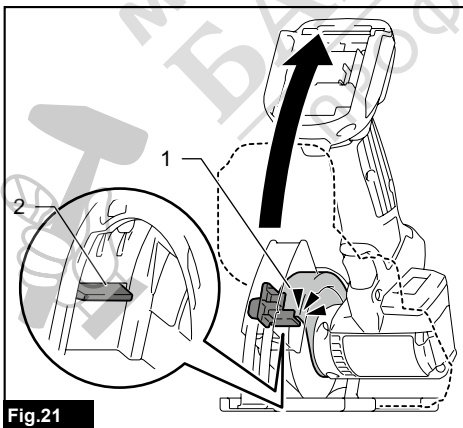
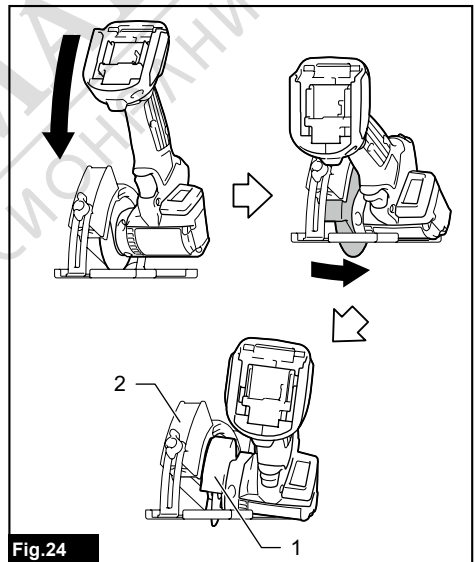
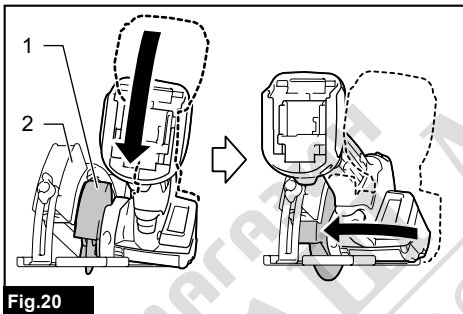
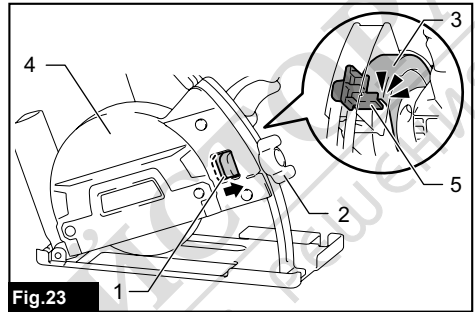
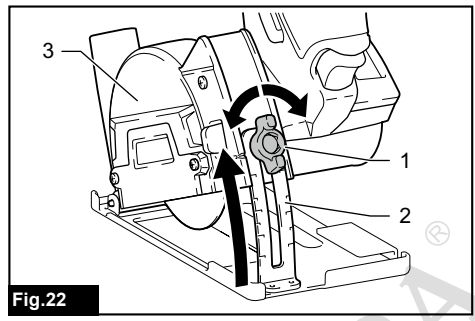
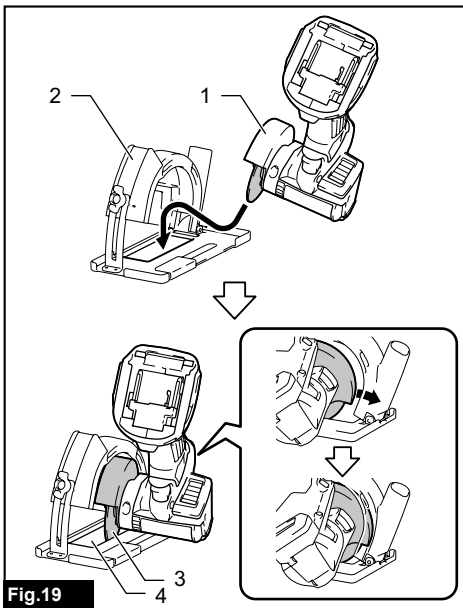
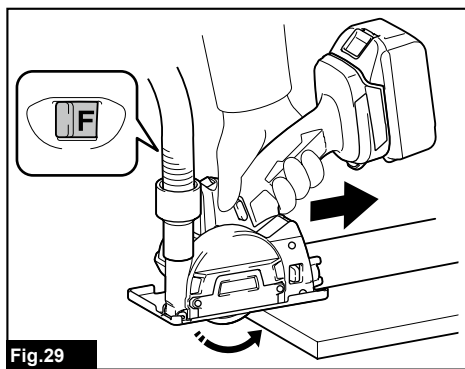
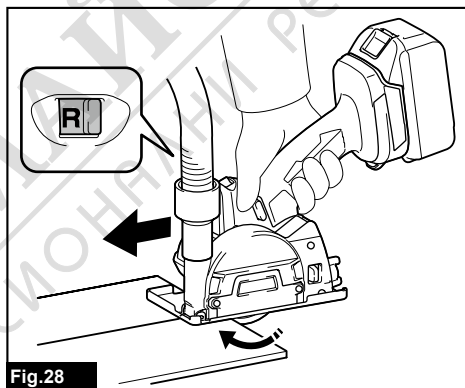
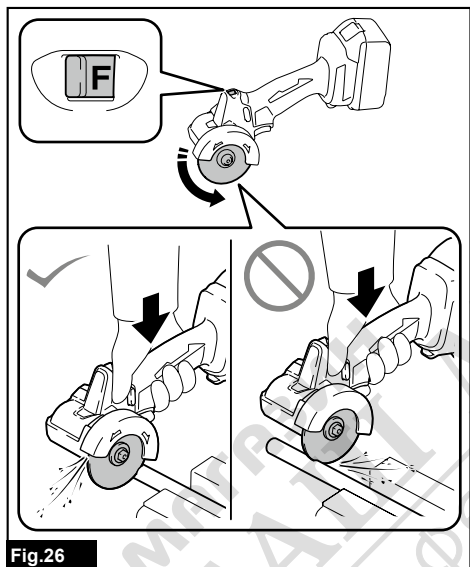
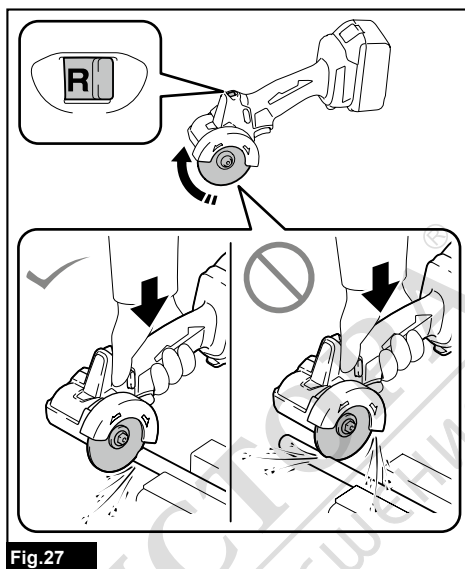
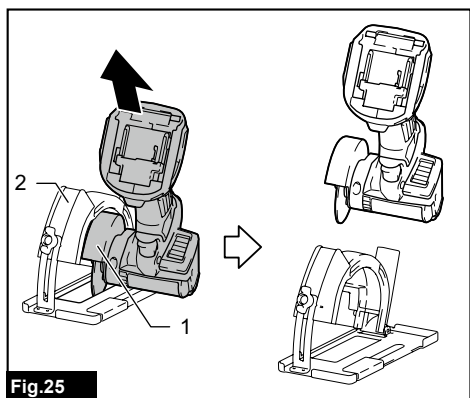
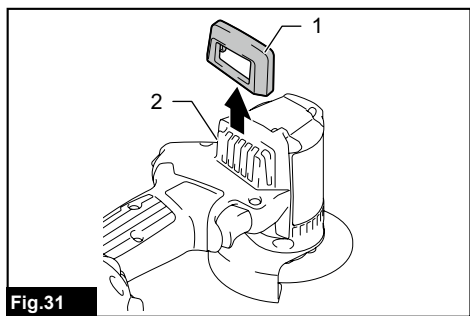
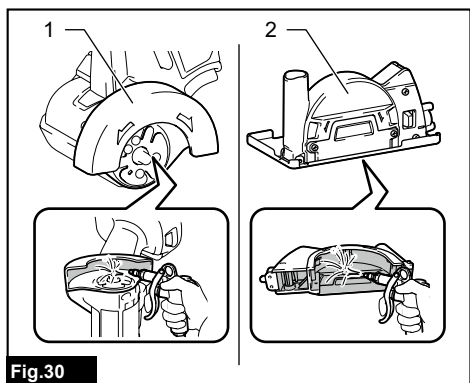

Fig.18







МАГАЗИН МАЙСТОРА®
БАШ ПРОФЕСИОНАЛНИ РЕШЕНИЯ



SPECIFICATIONS

Model:		DMC300
Wheel outer diameter		76 mm
Wheel inner (arbor) diameter		10.0 mm / 9.5 mm (3/8") (country specific)
Max. wheel thickness		1.0 mm
Max. cutting capacities	With dust collect cover	13.5 mm
	Without dust collect cover	16.0 mm
Rated speed (n) / No load speed (n ₀)		20,000 min ⁻¹
Overall length		271 mm *1
Rated voltage		D.C. 18 V
Net weight		1.2 - 1.7 kg

*1. With battery cartridge (BL1860B) / Without dust collection cover

- Due to our continuing program of research and development, the specifications herein are subject to change without notice.
- Specifications and battery cartridge may differ from country to country.
- The weight may differ depending on the attachment(s), including the battery cartridge. The lightest and heaviest combinations, according to EPTA-Procedure 01/2014, are shown in the table.

Applicable battery cartridge and charger

Battery cartridge	BL1815N / BL1820B / BL1830B / BL1840B / BL1850B / BL1860B
Charger	DC18RC / DC18RD / DC18RE / DC18SD / DC18SE / DC18SF / DC18SH / DC18WC

- Some of the battery cartridges and chargers listed above may not be available depending on your region of residence.

⚠WARNING: Only use the battery cartridges and chargers listed above. Use of any other battery cartridges and chargers may cause injury and/or fire.

Intended use

The tool is intended for cutting a sheet, fitting, pipe, tile or wall in metal, plastic, ceramic, plaster and similar composite materials without use of water.

Noise

The typical A-weighted noise level determined according to EN60745-2-22:

Sound pressure level (L_{pA}) : 88 dB (A)

Sound power level (L_{WA}) : 99 dB (A)

Uncertainty (K) : 3 dB (A)

NOTE: The declared noise emission value(s) has been measured in accordance with a standard test method and may be used for comparing one tool with another.

NOTE: The declared noise emission value(s) may also be used in a preliminary assessment of exposure.

⚠WARNING: Wear ear protection.

⚠WARNING: The noise emission during actual use of the power tool can differ from the declared value(s) depending on the ways in which the tool is used especially what kind of workpiece is processed.

⚠WARNING: Be sure to identify safety measures to protect the operator that are based on an estimation of exposure in the actual conditions of use (taking account of all parts of the operating cycle such as the times when the tool is switched off and when it is running idle in addition to the trigger time).

Vibration

The vibration total value (tri-axial vector sum) determined according to EN60745-2-22:

Work mode: concrete cutting (thickness 5 mm)

Vibration emission (a_h) : 3.0 m/s²

Uncertainty (K) : 1.5 m/s²

NOTE: The declared vibration total value(s) has been measured in accordance with a standard test method and may be used for comparing one tool with another.

NOTE: The declared vibration total value(s) may also be used in a preliminary assessment of exposure.

⚠WARNING: The vibration emission during actual use of the power tool can differ from the declared value(s) depending on the ways in which the tool is used especially what kind of workpiece is processed.

⚠WARNING: Be sure to identify safety measures to protect the operator that are based on an estimation of exposure in the actual conditions of use (taking account of all parts of the operating cycle such as the times when the tool is switched off and when it is running idle in addition to the trigger time).

Declarations of Conformity

For European countries only

The Declarations of conformity are included in Annex A to this instruction manual.

SAFETY WARNINGS

General power tool safety warnings

⚠WARNING Read all safety warnings, instructions, illustrations and specifications provided with this power tool. Failure to follow all instructions listed below may result in electric shock, fire and/or serious injury.

Save all warnings and instructions for future reference.

The term "power tool" in the warnings refers to your mains-operated (corded) power tool or battery-operated (cordless) power tool.

Compact cut off safety warnings

1. **The guard provided with the tool must be securely attached to the power tool and positioned for maximum safety, so the least amount of wheel is exposed towards the operator. Position yourself and bystanders away from the plane of the rotating wheel.** The guard helps to protect operator from broken wheel fragments and accidental contact with wheel.
2. **Use only bonded reinforced or diamond cut-off wheels for your power tool.** Just because an accessory can be attached to your power tool, it does not assure safe operation.
3. **The rated speed of the accessory must be at least equal to the maximum speed marked on the power tool.** Accessories running faster than their rated speed can break and fly apart.
4. **Wheels must be used only for recommended applications. For example: do not grind with the side of cut-off wheel.** Abrasive cut-off wheels are intended for peripheral grinding, side forces applied to these wheels may cause them to shatter.

5. **Always use undamaged wheel flanges that are of correct diameter for your selected wheel.** Proper wheel flanges support the wheel thus reducing the possibility of wheel breakage.
6. **Do not use worn down reinforced wheels from larger power tools.** Wheels intended for a larger power tool are not suitable for the higher speed of a smaller tool and may burst.
7. **The outside diameter and the thickness of your accessory must be within the capacity rating of your power tool.** Incorrectly sized accessories cannot be adequately guarded or controlled.
8. **The arbour size of wheels and flanges must properly fit the spindle of the power tool.** Wheels and flanges with arbour holes that do not match the mounting hardware of the power tool will run out of balance, vibrate excessively and may cause loss of control.
9. **Do not use damaged wheels. Before each use, inspect the wheels for chips and cracks. If power tool or wheel is dropped, inspect for damage or install an undamaged wheel. After inspecting and installing the wheel, position yourself and bystanders away from the plane of the rotating wheel and run the power tool at maximum no load speed for one minute.** Damaged wheels will normally break apart during this test time.
10. **Wear personal protective equipment. Always wear hearing protection. Depending on application, use face shield, safety goggles or safety glasses. As appropriate, wear dust mask, gloves and shop apron capable of stopping small abrasive or workpiece fragments.** The eye protection must be capable of stopping flying debris generated by various operations. The dust mask or respirator must be capable of filtering particles generated by your operation. Prolonged exposure to high intensity noise may cause hearing loss.
11. **Keep bystanders a safe distance away from work area. Anyone entering the work area must wear personal protective equipment.** Fragments of workpiece or of a broken wheel may fly away and cause injury beyond immediate area of operation.
12. **Hold the power tool by insulated gripping surfaces only, when performing an operation where the cutting accessory may contact hidden wiring.** Cutting accessory contacting a "live" wire may make exposed metal parts of the power tool "live" and could give the operator an electric shock.
13. **Never lay the power tool down until the accessory has come to a complete stop.** The spinning wheel may grab the surface and pull the power tool out of your control.
14. **Do not run the power tool while carrying it at your side.** Accidental contact with the spinning accessory could snag your clothing, pulling the accessory into your body.
15. **Regularly clean the power tool's air vents.** The motor's fan will draw the dust inside the housing and excessive accumulation of powdered metal may cause electrical hazards.

16. **Do not operate the power tool near flammable materials.** Sparks could ignite these materials.
17. **Do not use accessories that require liquid coolants.** Using water or other liquid coolants may result in electrocution or shock.

Kickback and related warnings

Kickback is a sudden reaction to a pinched or snagged rotating wheel. Pinching or snagging causes rapid stalling of the rotating wheel which in turn causes the uncontrolled power tool to be forced in the direction opposite of the wheel's rotation at the point of the binding.

For example, if an abrasive wheel is snagged or pinched by the workpiece, the edge of the wheel that is entering into the pinch point can dig into the surface of the material causing the wheel to climb out or kick out. The wheel may either jump toward or away from the operator, depending on direction of the wheel's movement at the point of pinching. Abrasive wheels may also break under these conditions.

Kickback is the result of power tool misuse and/or incorrect operating procedures or conditions and can be avoided by taking proper precautions as given below.

1. **Maintain a firm grip on the power tool and position your body and arm to allow you to resist kickback forces. Always use auxiliary handle, if provided, for maximum control over kickback or torque reaction during start-up.** The operator can control torque reactions or kickback forces, if proper precautions are taken.
2. **Never place your hand near the rotating accessory.** Accessory may kickback over your hand.
3. **Do not position your body in line with the rotating wheel.** Kickback will propel the tool in direction opposite to the wheel's movement at the point of snagging.
4. **Use special care when working corners, sharp edges etc. Avoid bouncing and snagging the accessory.** Corners, sharp edges or bouncing have a tendency to snag the rotating accessory and cause loss of control or kickback.
5. **Do not attach a saw chain, woodcarving blade, segmented diamond wheel with a peripheral gap greater than 10 mm or toothed saw blade.** Such blades create frequent kickback and loss of control.
6. **Do not "jam" the wheel or apply excessive pressure. Do not attempt to make an excessive depth of cut.** Overstressing the wheel increases the loading and susceptibility to twisting or binding of the wheel in the cut and the possibility of kickback or wheel breakage.
7. **When wheel is binding or when interrupting a cut for any reason, switch off the power tool and hold the power tool motionless until the wheel comes to a complete stop. Never attempt to remove the wheel from the cut while the wheel is in motion otherwise kickback may occur.** Investigate and take corrective action to eliminate the cause of wheel binding.
8. **Do not restart the cutting operation in the workpiece. Let the wheel reach full speed and carefully re-enter the cut.** The wheel may bind, walk up or kickback if the power tool is restarted in the workpiece.

9. **Support panels or any oversized workpiece to minimize the risk of wheel pinching and kickback.** Large workpieces tend to sag under their own weight. Supports must be placed under the workpiece near the line of cut and near the edge of the workpiece on both sides of the wheel.
10. **Use extra caution when making a "pocket cut" into existing walls or other blind areas.** The protruding wheel may cut gas or water pipes, electrical wiring or objects that can cause kickback.
11. **Before using a segmented diamond wheel, make sure that the diamond wheel has the peripheral gap between segments of 10 mm or less, only with a negative rake angle.**

Additional Safety Warnings:

1. **Never attempt to cut with the tool held upside down in a vise.** This can lead to serious accidents, because it is extremely dangerous.
2. **Check that the workpiece is properly supported.**
3. **Some material contains chemicals which may be toxic. Take caution to prevent dust inhalation and skin contact. Follow material supplier safety data.**
4. **Store wheels as per manufacturer recommendations.** Improper storage may damage the wheels.

SAVE THESE INSTRUCTIONS.

⚠WARNING: DO NOT let comfort or familiarity with product (gained from repeated use) replace strict adherence to safety rules for the subject product. MISUSE or failure to follow the safety rules stated in this instruction manual may cause serious personal injury.

Important safety instructions for battery cartridge

1. **Before using battery cartridge, read all instructions and cautionary markings on (1) battery charger, (2) battery, and (3) product using battery.**
2. **Do not disassemble or tamper with the battery cartridge.** It may result in a fire, excessive heat, or explosion.
3. **If operating time has become excessively shorter, stop operating immediately. It may result in a risk of overheating, possible burns and even an explosion.**
4. **If electrolyte gets into your eyes, rinse them out with clear water and seek medical attention right away. It may result in loss of your eyesight.**
5. **Do not short the battery cartridge:**
 - (1) **Do not touch the terminals with any conductive material.**
 - (2) **Avoid storing battery cartridge in a container with other metal objects such as nails, coins, etc.**
 - (3) **Do not expose battery cartridge to water or rain.**

A battery short can cause a large current flow, overheating, possible burns and even a breakdown.

6. Do not store and use the tool and battery cartridge in locations where the temperature may reach or exceed 50 °C (122 °F).
7. Do not incinerate the battery cartridge even if it is severely damaged or is completely worn out. The battery cartridge can explode in a fire.
8. Do not nail, cut, crush, throw, drop the battery cartridge, or hit against a hard object to the battery cartridge. Such conduct may result in a fire, excessive heat, or explosion.
9. Do not use a damaged battery.
10. The contained lithium-ion batteries are subject to the Dangerous Goods Legislation requirements.

For commercial transports e.g. by third parties, forwarding agents, special requirement on packaging and labeling must be observed.

For preparation of the item being shipped, consulting an expert for hazardous material is required. Please also observe possibly more detailed national regulations.

Tape or mask off open contacts and pack up the battery in such a manner that it cannot move around in the packaging.

11. When disposing the battery cartridge, remove it from the tool and dispose of it in a safe place. Follow your local regulations relating to disposal of battery.
12. Use the batteries only with the products specified by Makita. Installing the batteries to non-compliant products may result in a fire, excessive heat, explosion, or leak of electrolyte.
13. If the tool is not used for a long period of time, the battery must be removed from the tool.
14. During and after use, the battery cartridge may take on heat which can cause burns or low temperature burns. Pay attention to the handling of hot battery cartridges.
15. Do not touch the terminal of the tool immediately after use as it may get hot enough to cause burns.
16. Do not allow chips, dust, or soil stuck into the terminals, holes, and grooves of the battery cartridge. It may cause heating, catching fire, burst and malfunction of the tool or battery cartridge, resulting in burns or personal injury.
17. Unless the tool supports the use near high-voltage electrical power lines, do not use the battery cartridge near high-voltage electrical power lines. It may result in a malfunction or breakdown of the tool or battery cartridge.
18. Keep the battery away from children.

SAVE THESE INSTRUCTIONS.

CAUTION: Only use genuine Makita batteries. Use of non-genuine Makita batteries, or batteries that have been altered, may result in the battery bursting causing fires, personal injury and damage. It will also void the Makita warranty for the Makita tool and charger.

Tips for maintaining maximum battery life

1. Charge the battery cartridge before completely discharged. Always stop tool operation and charge the battery cartridge when you notice less tool power.
2. Never recharge a fully charged battery cartridge. Overcharging shortens the battery service life.
3. Charge the battery cartridge with room temperature at 10 °C - 40 °C (50 °F - 104 °F). Let a hot battery cartridge cool down before charging it.
4. When not using the battery cartridge, remove it from the tool or the charger.
5. Charge the battery cartridge if you do not use it for a long period (more than six months).

FUNCTIONAL DESCRIPTION

CAUTION: Always be sure that the tool is switched off and the battery cartridge is removed before adjusting or checking function on the tool.

Installing or removing battery cartridge

CAUTION: Always switch off the tool before installing or removing of the battery cartridge.

CAUTION: Hold the tool and the battery cartridge firmly when installing or removing battery cartridge. Failure to hold the tool and the battery cartridge firmly may cause them to slip off your hands and result in damage to the tool and battery cartridge and a personal injury.

► Fig.1: 1. Red indicator 2. Button 3. Battery cartridge

To remove the battery cartridge, slide it from the tool while sliding the button on the front of the cartridge.

To install the battery cartridge, align the tongue on the battery cartridge with the groove in the housing and slip it into place. Insert it all the way until it locks in place with a little click. If you can see the red indicator as shown in the figure, it is not locked completely.

CAUTION: Always install the battery cartridge fully until the red indicator cannot be seen. If not, it may accidentally fall out of the tool, causing injury to you or someone around you.

CAUTION: Do not install the battery cartridge forcibly. If the cartridge does not slide in easily, it is not being inserted correctly.

Indicating the remaining battery capacity

Only for battery cartridges with the indicator

► Fig.2: 1. Indicator lamps 2. Check button

Press the check button on the battery cartridge to indicate the remaining battery capacity. The indicator lamps light up for a few seconds.

Indicator lamps			Remaining capacity
Lighted	Off	Blinking	
■ ■ ■ ■	□ □ □ □	▬	75% to 100%
■ ■ ■ □	□ □ □ □	▬	50% to 75%
■ ■ □ □	□ □ □ □	▬	25% to 50%
■ □ □ □	□ □ □ □	▬	0% to 25%
▬ □ □ □	□ □ □ □	▬	Charge the battery.
■ ■ □ □	□ □ □ □	▬	The battery may have malfunctioned.
□ □ ■ ■	□ □ □ □	▬	

NOTE: Depending on the conditions of use and the ambient temperature, the indication may differ slightly from the actual capacity.

NOTE: The first (far left) indicator lamp will blink when the battery protection system works.

Tool / battery protection system

The tool is equipped with a tool/battery protection system. This system automatically cuts off power to the motor to extend tool and battery life. The tool will automatically stop during operation if the tool or battery is placed under one of the following conditions.

Overload protection

When the tool/battery is operated in a manner that causes it to draw an abnormally high current, the tool stops automatically and the operation lamp will blink. In this situation, turn the tool off and stop the application that caused the tool to become overloaded. Then turn the tool on to restart.

Overheat protection

When the tool/battery is overheated, the tool stops automatically and the operation lamp will blink. In this situation, let the tool cool down before turning the tool on again.

Overdischarge protection

When the battery capacity becomes low, the tool stops automatically. If the tool does not run along with the switch operation, remove the battery from the tool and charge it.

Protections against other causes

Protection system is also designed for other causes that could damage the tool and allows the tool to stop automatically. Take all the following steps to clear the causes, when the tool has been brought to a temporary halt or stop in operation.

1. Turn the tool off, and then turn it on again to restart.
2. Charge the battery(ies) or replace it/them with recharged battery(ies).
3. Let the tool and battery(ies) cool down.

If no improvement can be found by restoring protection system, then contact your local Makita Service Center.

Switch action

WARNING: NEVER use the tool if it runs when you simply pull the switch trigger without pressing the lock-off button. A switch in need of repair may result in unintentional operation and serious personal injury. Return tool to a Makita service center for proper repairs BEFORE further usage.

WARNING: NEVER defeat the lock-off button by taping down or some other means. A switch with a negated lock-off button may result in unintentional operation and serious personal injury.

CAUTION: Before installing the battery cartridge into the tool, always check to see that the switch trigger actuates properly and returns to the "OFF" position when released.

CAUTION: Do not pull the switch trigger hard without pressing in the lock-off button. This can cause switch breakage.

CAUTION: The tool starts to brake the wheel rotation immediately after you release the switch trigger. Hold the tool firmly to respond the reaction of the brake when releasing the switch trigger. Sudden reaction can drop the tool off your hand and can cause a personal injury.

To prevent the switch trigger from being accidentally pulled, a lock-off button is provided. To start the tool, press and hold the lock-off button, and then pull the switch trigger. Release the switch trigger to stop.

► Fig.3: 1. Switch trigger 2. Lock-off button

Wheel selection

CAUTION: The outside diameter, thickness and rated speed of your accessory must be within the capacity rating of your power tool.

CAUTION: Wheels must be used only for recommended applications.

Select one of the most appropriate types of cutting wheels according to your application.

Wheel type	Practical applications
Cut off wheel	Cutting steel, stainless steel, metals
Tungsten carbide grit wheel	Cutting plastics, plaster, composite materials
Diamond Wheel	Cutting tiles, ceramics

Wheel rotation direction

⚠ CAUTION: Always check the direction of rotation before operation.

⚠ CAUTION: Use the reversing switch only after the tool comes to a complete stop. A sudden switch in rotation direction during operation brings the tool to a sharp stop for safety reasons.

Wheel rotation can be changed in either forward or reverse direction.

To set the forward rotation, slide the reversing switch to the left until "F" indication appears on the switch.

To select the reverse rotation, slide the reversing switch to the right until "R" indication appears on the switch.

► **Fig.4:** 1. Reversing switch

Chips, debris, sparks, and cutting particles tend to fly off along a tangent direction of the wheel rotation. Use the wheel guard effectively to avoid continued exposure towards cut-off particles so it can discharge some of cutting dust and particles into an alternative direction.

A reaction to a rapid stalling of the rotating wheel could make the tool uncontrolled in the direction opposite to the wheel rotation.

Forward rotation

► **Fig.5:** 1. Cut-off particles 2. Reactions

Reverse rotation

► **Fig.6:** 1. Cut-off particles 2. Reactions

Wheel guard

⚠ CAUTION: Make sure that the wheel guard is correctly and firmly positioned behind the cutting wheel before operation.

Secure the wheel guard in a comfortable position, for maximum safety and minimum exposure to possible risk factors, according to your work conditions and preferences.

Positioning forwards

► **Fig.7:** 1. Wheel guard 2. Cutting wheel

Positioning backwards

► **Fig.8:** 1. Wheel guard 2. Cutting wheel

Shaft lock

Press the shaft lock to prevent spindle rotation when installing and removing a cutting wheel.

► **Fig.9:** 1. Shaft lock

NOTICE: Never actuate the shaft lock when the spindle is moving. The tool may be damaged.

Operation lamp

⚠ CAUTION: Do not look in the light or see the source of light directly.

To turn on the operation lamp, press and hold the lock-off button and pull the switch trigger.

The lamp goes out approximately 15 seconds after releasing the switch trigger.

► **Fig.10:** 1. Operation lamp

NOTICE: When the tool is operated with excessive load, the operation lamp flashes. In this situation, release the switch trigger, and then reduce the load on the tool before operating again.

NOTICE: When the tool is overheated, the operation lamp flashes. In this case, release the switch trigger, and then cool down the tool/battery before operating again.

NOTE: Use a dry cloth to wipe the dirt off the lens of the lamp. Be careful not to scratch the lens of lamp, or it may lower the illumination.

Adjusting depth of cut

⚠ CAUTION: After adjusting the depth of cut, always tighten the thumb screw securely.

With the dust collection cover installed, fine adjustments in the cutting depth can be made up to 13.5 mm.

Loosen the thumb screw on the depth scale. Lift or lower the tool handle into position to align the depth indicators on the cover with your desired cutting depth on the scale. Then tightening the thumb screw.

► **Fig.11:** 1. Thumb screw 2. Depth scale 3. Depth indicator

⚠ CAUTION: For clean and safe cutting, set the cutting depths so that a cutting wheel overpasses the undersurface of workpiece by 2.0 mm or less. Setting in proper cutting depths helps to reduce potential for dangerous kickbacks which may cause personal injury.

Sighting for straight cutting

With the dust collection cover installed, straight cut operation can safely be performed by aligning the cutting wheel toward the cutting direction before the actual cut operation.

Align the guide notch in the base of dust collection cover with your intended cutting line on the workpiece.

► **Fig.12:** 1. Guide notch 2. Base 3. Cutting line

Connecting a vacuum cleaner

Optional accessory

When you wish to perform clean cutting operation, connect a Makita vacuum cleaner to the dust nozzle in the dust collection cover using a front cuffs 22 (optional accessory).

► **Fig.13:** 1. Front cuffs 22 2. Dust nozzle 3. Hose 4. Vacuum cleaner

Accidental re-start preventive function

When installing the battery cartridge while pulling the switch trigger, the tool will not start.

To start the tool, release the switch trigger first. Press and hold the lock-off button, and then pull the switch trigger.

Electronic function

The tool is equipped with the electronic functions for easy operation.

- **Electric brake**
This tool is equipped with an electric brake. If the tool consistently fails to quickly cease to function after the switch trigger is released, have the tool serviced at a Makita service center.
- **Constant speed control**
The speed control function provides the constant rotation speed regardless of load conditions.
- **Active Feedback sensing Technology**
The tool electronically detects situations in which the cutting wheel may be at risk to be bound. In the situation, the tool automatically stops to prevent further rotation of the spindle (it does not prevent kickback).
In this case, release the switch trigger first, remove the cause of sudden drop in the rotation speed, and then pull the switch trigger to restart the tool.

ASSEMBLY

CAUTION: Always be sure that the tool is switched off and the battery cartridge is removed before carrying out any work on the tool.

Hex wrench storage

When not in use, store the hex wrench as shown in the figure to keep it from being lost.

- **Fig.14:** 1. Hex wrench

Removing and installing cutting wheel

CAUTION: Use only the Makita hex wrench supplied to remove and install a cutting wheel.

CAUTION: When installing a cutting wheel, be sure to tighten the bolt securely.

NOTICE: When installing a diamond wheel for its best performance, always make sure that the arrows on the diamond wheel point in the same direction as your desired wheel rotation.

To remove a cutting wheel, press the shaft lock fully so that the cutting wheel cannot revolve and use the hex wrench to loosen the hex bolt counterclockwise. Then remove the hex bolt, outer flange and cutting wheel.

- **Fig.15:** 1. Shaft lock 2. Hex wrench 3. Hex bolt 4. Loosen 5. Tightly

NOTICE: If the inner flange is removed, place it back onto the spindle with its wheel mounting part facing upwards.

To install a cutting wheel, follow the removal procedure in reverse.

- **Fig.16:** 1. Hex bolt 2. Outer flange 3. Cutting wheel 4. Inner flange 5. Spindle

Installing and removing dust collection cover

CAUTION: Make sure that the wheel guard is securely locked by the stopper inside the dust collection cover before operation.

CAUTION: Avoid using the dust collection cover for metalwork which creates heats and flying sparks as it may melt the plastic components of the dust collection cover.

The dust collection cover enhances safe and efficient cutting operation, providing a safeguard against rotating wheel, cutting stability, precise control over cutting depth, and dust extraction solutions, especially at tile, plaster, stoneware cuttings.

Installing dust collection cover

1. Loosen the thumb screw on the depth scale of the dust collection cover. Lift the cover fully up, and then tighten the thumb screw to secure the dust collection cover in a raised position.

► **Fig.17:** 1. Thumb screw 2. Depth scale 3. Dust collection cover

2. Set the wheel guard on the tool in a forward position.

► **Fig.18:** 1. Wheel guard

3. Raise the tool handle slightly and place the front half of the wheel guard at an angle into the dust collection cover, throwing the bottom of the cutting wheel down through the wheel slot in the base.

► **Fig.19:** 1. Wheel guard 2. Dust collection cover 3. Cutting wheel 4. Wheel slot

4. Install the rear half of the wheel guard in the dust collection cover, while lowering the tool handle from a raised position to a down position.

► **Fig.20:** 1. Wheel guard 2. Dust collection cover

5. Raise the tool handle again to hook the rear edge of the wheel guard over the stopper inside the dust collection cover.

► **Fig.21:** 1. Wheel guard 2. Stopper

6. Loosen the thumb screw. Swing the tool up and down at your desired cutting depth. Then tighten the thumb screw to secure the tool in place.

Removing dust collection cover

1. Loosen the thumb screw on the depth scale of the dust collection cover. Lift the tool handle fully up, and then tighten the thumb screw to secure the dust collection cover in a raised position.

► **Fig.22:** 1. Thumb screw 2. Depth scale 3. Dust collection cover

2. Slide the release lever towards the thumb screw to unlock the wheel guard from the stopper inside the dust collection cover.

► **Fig.23:** 1. Release lever 2. Thumb screw 3. Wheel guard 4. Dust collection cover 5. Stopper

3. Dismount the rear half of the wheel guard from the dust collection cover, while lowering the tool handle from a raised position to a down position.

► Fig.24: 1. Wheel guard 2. Dust collection cover

4. Pull the front half of the wheel guard, at a slight upward and outward angle, apart from the dust collection cover.

► Fig.25: 1. Wheel guard 2. Dust collection cover

OPERATION

CAUTION: Always maintain a firm grip on the tool during operation.

CAUTION: Do not force the tool. Forcing and exerting excessive pressure or allowing the wheel to bend, pinch or twist in the cut can cause overheating of the motor and dangerous kickback of the tool.

CAUTION: When cutting plastics, be sure not to overheat the cutting wheel. It may result in melting the workpiece.

CAUTION: Do not bang or bump a cutting wheel when starting or during operation.

CAUTION: Always wear safety goggles or a face shield during operation.

CAUTION: After operation, always switch off the tool and wait until the wheel has come to a complete stop before putting the tool down.

Down cutting

NOTICE: Exercise due care about using an effective cutting surface of the wheel so as to avoid exposure towards cut-off particles.

NOTICE: Keep a cutting wheel stand straight in workpiece and avoid tilting or swinging the tool during operation.

Position the wheel guard correctly to provide maximum protection from sparks and loose particles thrown from the cutting wheel. Place the tool over workpiece without the cutting wheel making any contact. Turn the tool on and wait until the cutting wheel attains full speed. Then slowly lower the tool over the workpiece surface, using a moderate feed suited to your applications.

Forward rotation

► Fig.26

Reverse rotation

► Fig.27

Straight cutting

CAUTION: Be sure that a cutting wheel always works in an up-grinding motion. It otherwise may cause the tool to be pushed uncontrolled out of the cut.

NOTICE: Keep your cutting line straight and apply steady pressure to obtain a uniform cut through workpiece.

Set the base plate of dust collection cover on workpiece to be cut without the cutting wheel making any contact. Turn the tool on and wait until the cutting wheel attains full speed. Then slowly move the tool over the workpiece surface, keeping it flat and advancing smoothly until the cutting is completed. Select the reverse rotation for push cutting, and the forward rotation for pull cutting.

Push cutting in reverse rotation

► Fig.28

Pull cutting in forward rotation

► Fig.29

NOTE: Be aware that the dust collection cover tends to function less effectively in pull cutting as some cutting particles spread inside the cover against the dust extraction flow.

MAINTENANCE

CAUTION: Always be sure that the tool is switched off and the battery cartridge is removed before attempting to perform inspection or maintenance.

NOTICE: Never use gasoline, benzine, thinner, alcohol or the like. Discoloration, deformation or cracks may result.

To maintain product SAFETY and RELIABILITY, repairs, any other maintenance or adjustment should be performed by Makita Authorized or Factory Service Centers, always using Makita replacement parts.

Dressing diamond wheel

If the cutting action of the diamond wheel begins to diminish, use an old discarded coarse grit bench grinder wheel or concrete block to dress the diamond wheel. To do this, tightly secure the bench grinder wheel or concrete block and cut in it.

After use

Clean the dust inside the tool by running the tool at an idle for a while. Accumulation of dust in the motor may cause a malfunction of the tool.

Cleaning wheel guard and dust collection cover

Clean inside the wheel guard and dust collection cover at regular intervals. Blow or wipe off any dirt or dust accumulated in them.

► **Fig.30:** 1. Wheel guard 2. Dust collection cover

Air vent cleaning

Clean the air vents of the tool at regular intervals for smooth air circulation. Remove the dust cover from inhalation vent and clean it whenever it becomes dirt and clogged.

► **Fig.31:** 1. Dust cover 2. Inhalation vent

OPTIONAL ACCESSORIES

⚠CAUTION: These accessories or attachments are recommended for use with your Makita tool specified in this manual. The use of any other accessories or attachments might present a risk of injury to persons. Only use accessory or attachment for its stated purpose.

If you need any assistance for more details regarding these accessories, ask your local Makita Service Center.

- Cut off wheel
- Diamond wheel
- Tungsten carbide grit wheel
- Hex wrench
- Makita genuine battery and charger

NOTE: Some items in the list may be included in the tool package as standard accessories. They may differ from country to country.

